



Artisan Scientific

QUALITY INSTRUMENTATION ... GUARANTEED

Looking for more information?

Visit us on the web at <http://www.artisan-scientific.com> for more information:

- Price Quotations
- Drivers
- Technical Specifications, Manuals and Documentation

Artisan Scientific is Your Source for Quality New and Certified-Used/Pre-owned Equipment

- Tens of Thousands of In-Stock Items
- Hundreds of Manufacturers Supported
- Fast Shipping and Delivery
- Leasing / Monthly Rentals
- Equipment Demos
- Consignment

Service Center Repairs

Experienced Engineers and Technicians on staff in our State-of-the-art Full-Service In-House Service Center Facility

InstraView™ Remote Inspection

Remotely inspect equipment before purchasing with our Innovative InstraView™ website at <http://www.instraview.com>

We buy used equipment! We also offer credit for Buy-Backs and Trade-Ins

Sell your excess, underutilized, and idle used equipment. Contact one of our Customer Service Representatives today!

Talk to a live person: 888-88-SOURCE (888-887-6872) | Contact us by email: sales@artisan-scientific.com | Visit our website: <http://www.artisan-scientific.com>



HM-6136-5

VEXTA®

AC Servo-motor

KBLII Series

OPERATING MANUAL

Thank you for purchasing ORIENTAL MOTOR products .
Please read this operating manual thoroughly before installing and operating the motor, and always keep the manual where it is readily accessible.

© Copyright ORIENTAL MOTOR CO., LTD. 2000

This product is designed to be incorporated in the general industrial machinery, and must not be used for other purposes. It should be noted in advance that ORIENTAL MOTOR CO., LTD. is not responsible for any damages caused by ignoring this warning.

Contents

| | |
|---|----|
| 1. Precautions | 4 |
| 2. Before Use | 4 |
| 2.1 Before Use | 4 |
| 2.2 Product Number Code | 4 |
| 2.3 Suitable Motor-Driver Combinations | 4 |
| 3. Names and Functions of Components | 6 |
| 4. Mounting | 8 |
| 4.1 Shipping | 8 |
| 4.2 Mounting the Motor | 8 |
| 4.3 Connecting Gearhead to Motor | 9 |
| 4.4 Mounting the Motor on Machinery | 10 |
| 4.5 Installing the Driver | 11 |
| 5. Connections | 13 |
| 5.1 Before Connecting the Equipment | 13 |
| 5.2 Connections | 13 |
| 5.3 Connecting the Motor and Driver (CN-1) | 14 |
| 5.4 Connecting the Driver and Power Supply | 15 |
| 5.5 Noise Suppression, Grounding method | 16 |
| 5.6 Installation of the leakage breakers | 16 |
| 5.7 Methods of Speed Setting and Their Connection | 17 |
| 6. Function • Operation | 19 |
| 6.1 Control Input Output Circuits (I/O) | 19 |
| 6.2 Input Signal Circuit | 21 |
| 6.3 Output Signal Circuit | 21 |
| 6.4 Operation Timing Charts | 22 |
| 6.5 Use of the Electromagnetic Brake (Electromagnetic brake models) | 25 |
| 6.6 Multi-Motor Control Function | 26 |
| 6.7 Protection Functions | 27 |
| 7. Troubleshooting | 28 |
| 8. Specifications | 30 |
| 8.1 AC Servo motor/Servo driver Specifications | 30 |
| 8.2 General Specifications | 32 |
| 8.3 Geared motor Torque Table load of gearhead output shaft | 33 |
| 8.4 Permissible thrust load and permissible overhangload of gearhead output | 33 |
| 8.5 Lowering Operation Capacity | 34 |
| 8.6 Speed-Torque Characteristics | 35 |
| 8.7 Load Torque - Driver Input Current Characteristics | 35 |
| 9. Dimensions | 37 |
| 9.1 Servo Motor | 37 |
| 9.2 Servo Driver | 45 |
| 9.3 Accessory | 46 |

1. Precautions

- Do not use in a place where there is flammable gas and/or corrosive gas.
- The motor housing must be mounted with a screw and spring washer to the ground point of the equipment.
- When installing the motor into your equipment, ensure that the cable is fixed and does not move.
In addition, do not apply any pressure to the cable.
- Installation must be performed by a qualified installer.
- Under no circumstances should cabling work be performed when connecting the unit, since this can result in damage to the driver or motor, or cause errors in operation.

2. Before Use

2.1 Before Use

Check to see that you have received the complete product set, including accessories. If any parts are missing or damaged, please contact your nearest Oriental Motor sales office.

- (1) Motor
- (2) Driver
- (3) Junction cable
- (4) Driver mounting brackets : 2-pieces set Flat-headed screws : Set of 4 pieces
- (5) External speed potentiometer
- (6) Signal line for connection to external speed controller
- (7) Operating manual : 1 piece

2.2 Product Number Code

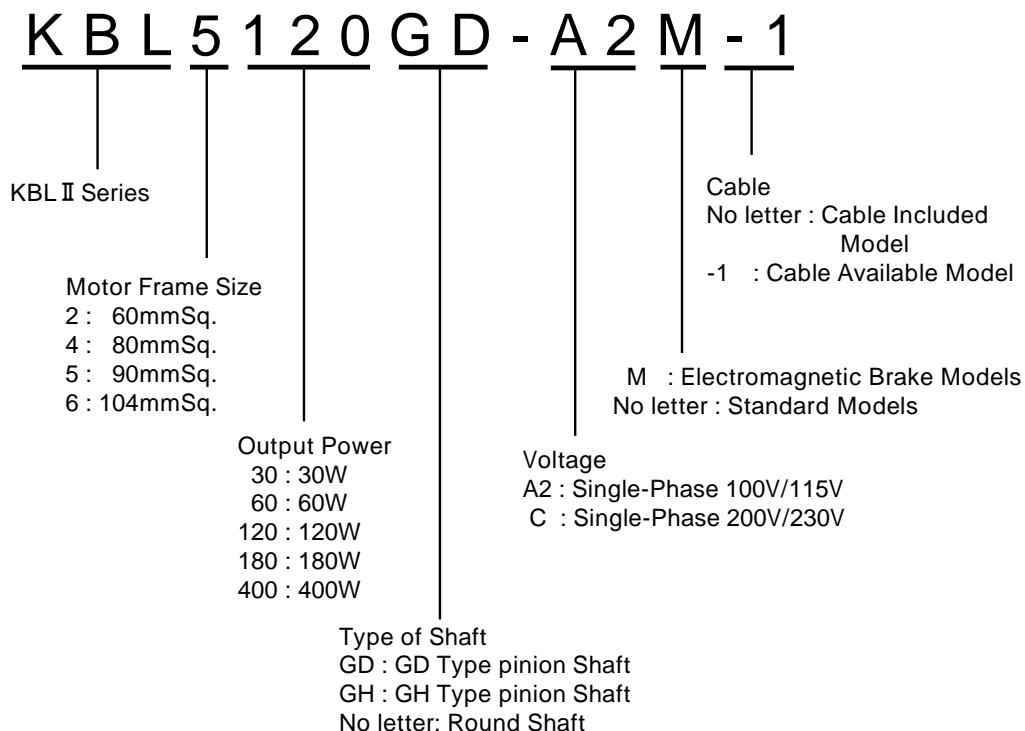

2.3 Suitable Motor-Driver Combinations

KBLII Series motors and drivers are shipped as a set. When you receive the product, check to see that you have a suitable motor-driver combination by referring to the tables below.

For 100/115V Power Supply

| Unit Model *1 | Servo Motor Model | Servo Driver Model | Accessories |
|---------------|-------------------|--------------------|--|
| KBL230-A2 | KBLM230-A | KBLD30-A | Junction Cable (1 piece) *2 Driver mounting brackets (2 pieces) Mounting screws (4 pieces) External speed potentiometer (1 piece) Signal Cable for external speed potentiometer (1m long) Manual (1 piece) O-ring *3 |
| KBL230-A2M | KBLM230-AM | | |
| KBL230GD-A2 | KBLM230GD-A | | |
| KBL230GD-A2M | KBLM230GD-AM | | |
| KBL460-A2 | KBLM460-A | KBLD60-A | |
| KBL460-A2M | KBLM460-AM | | |
| KBL460GD-A2 | KBLM460GD-A | | |
| KBL460GD-A2M | KBLM460GD-AM | | |
| KBL5120-A2 | KBLM5120-A | KBLD120-A | |
| KBL5120-A2M | KBLM5120-AM | | |
| KBL5120GD-A2 | KBLM5120GD-A | | |
| KBL5120GD-A2M | KBLM5120GD-AM | | |
| KBL6180-A2 | KBLM6180-A | KBLD180-A | |
| KBL6180-A2M | KBLM6180-AM | | |
| KBL6180GD-A2 | KBLM6180GD-A | | |
| KBL6180GD-A2M | KBLM6180GD-AM | | |

For 200/230V Power Supply

| Unit Model *1 | Servo Motor Model | Servo Driver Model | Accessories |
|---------------|-------------------|--------------------|--|
| KBL230-C | KBLM230-C | KBLD30-C | Junction Cable (1 piece) *2 Driver mounting brackets (2 pieces) Mounting screws (4 pieces) External speed potentiometer (1 piece) Signal Cable for external speed potentiometer (1m long) Manual (1 piece) O-ring *3 |
| KBL230-CM | KBLM230-CM | | |
| KBL230GD-C | KBLM230GD-C | | |
| KBL230GD-CM | KBLM230GD-CM | | |
| KBL460-C | KBLM460-C | KBLD60-C | |
| KBL460-CM | KBLM460-CM | | |
| KBL460GD-C | KBLM460GD-C | | |
| KBL460GD-CM | KBLM460GD-CM | | |
| KBL5120-C | KBLM5120-C | KBLD120-C | |
| KBL5120-CM | KBLM5120-CM | | |
| KBL5120GD-C | KBLM5120GD-C | | |
| KBL5120GD-CM | KBLM5120GD-CM | | |
| KBL6180-C | KBLM6180-C | KBLD180-C | |
| KBL6180-CM | KBLM6180-CM | | |
| KBL6180GD-C | KBLM6180GD-C | | |
| KBL6180GD-CM | KBLM6180GD-CM | | |
| KBL6400-C | KBLM6400-C | KBLD400-C | |
| KBL6400-CM | KBLM6400-CM | KBLD400-CM | |
| KBL6400GH-C | KBLM6400GH-C | KBLD400-C | |
| KBL6400GH-CM | KBLM6400GH-CM | KBLD400-CM | |

*1 Products requiring an extension cable (sold separately) are designated by a -1 at the end of the unit model (e.g. KBL230-A2-1) .

*2 Junction cable is included only with cable included models.

*3 The O-rings are fitted in the pilot section of pinion shaft type motors.

3. Names and Functions of Components

LED Indications

| Indication | Function | Lighting Conditions |
|--------------|--|---|
| POWER | Power indication | Lights when power is on. |
| ALARM | Overload protection Overvoltage protection Overheat protection | <p>Lights when the following protection functions are activated.</p> <ul style="list-style-type: none"> • Overload protection : Activated when a load that exceeds the rated torque is applied for a period of 5 seconds or more. • Overvoltage protection : Activated when the primary voltage of the driver's inverter exceeds the permissible value. • Overheat protection : Activated when the temperature of the driver's internal radiator rises to 80 . <p>When a protective function is activated, the alarm signal is output and the motor stops naturally.</p> <ul style="list-style-type: none"> * Operation can be restored by turning power back on. * In electromagnetic brake models, the motor is stopped instantaneously by the electromagnetic brake if the brake is being controlled automatically. |
| M.BRAKE FREE | Electromagnetic brake release indication | Lights when the electromagnetic brake release command is input to the M. BRAKE FREE input terminal. |

Input Signal Terminal Block

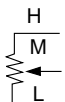
| Indication | Name of Signal | Function / Use |
|---|---------------------------------------|--|
| + 12V + 24V | 12V ~ 24V | This connection is not required when using the driver's built-in power supply (5V) . When using a power supply from an external source such as a programmable controller, input a positive voltage (DC+12V ~ 24V) . |
| STOP/START | Start/stop input | Input for starting and stopping the motor. The motor starts and stops in accordance with the acceleration and deceleration settings. |
| BRAKE/START | Brake input | Input for starting the motor and for effecting instantaneous motor stops. Motor stops instantaneously regardless of the deceleration setting, and starts in accordance with the acceleration setting. |
| CCW/CW | Direction of rotation selection input | Input for changing the direction of rotation of the motor shaft. Allows instantaneous reversal of direction. |
| M.BRAKE FREE | Electromagnetic brake release input | If this signal is input when the motor is stopped, the electromagnetic brake is released, allowing the motor shaft to be turned manually. This signal is not used in standard models. |
| SPEED SELECT 1 SPEED SELECT 2 | Speed selection input | These inputs can be used to select one of the built-in speed potentiometers (A, B, or C) or the external speed potentiometer. Using these input signals, it is possible to switch between up to four different speed levels. |
| INPUT GND (2 connections) | Input signal ground | Common ground for input signals. |
| N.C. | - | Not used. |
|  | External speed control input | Used for the external speed potentiometer, or when controlling speed by DC voltage. |
| SHIELD | Shield terminal | The signal line's braided shielding wire should be connected to the SHIELD terminal. |

Servo driver

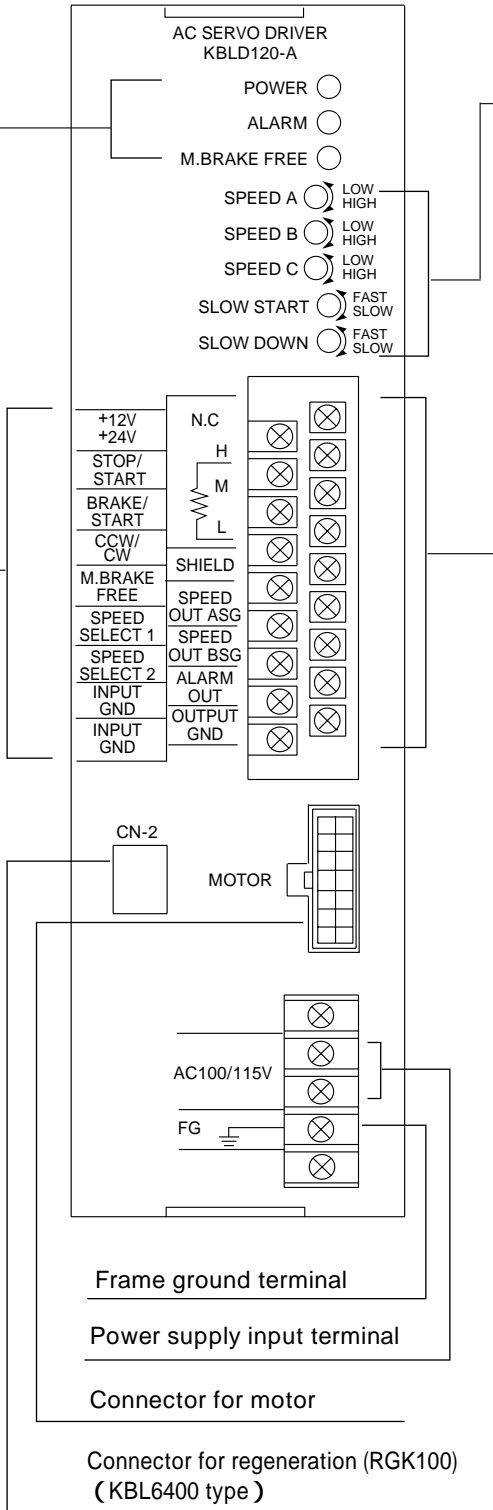

Built-in Speed Potentiometer

| Indication | Function |
|------------|---|
| SPEED A | Speed potentiometers |
| SPEED B | |
| SPEED C | |
| SPEED A | • Three different speed levels can be set using the A, B and C speed potentiometers. |
| SPEED B | • These speed levels are selected using the SPEED SELECT 1 and SPEED SELECT 2 inputs. |
| SPEED C | |
| SLOW START | Acceleration time setting potentiometer. |
| SLOW DOWN | Deceleration time setting potentiometer. |

Output Signal Terminal Block

| Indication | Signal Name | Function / Use |
|---------------|--------------------------------------|--|
| SPEED OUT ASG | Speed output (open collector output) | This signal is used when monitoring motor speed. The motor outputs 400 pulses per revolution. During clockwise rotation, pulses output by BSG are delayed with respect to ASG by 90° as expressed in electrical degrees. |
| SPEED OUT BSG | | |
| ALARM OUT | Alarm output (open collector output) | This signal is output when a protection is activated. At such times, the ALARM LED lights and the motor is stopped. |
| OUTPUT GND | Output signal ground | Common ground for output signals. |

Servo motor

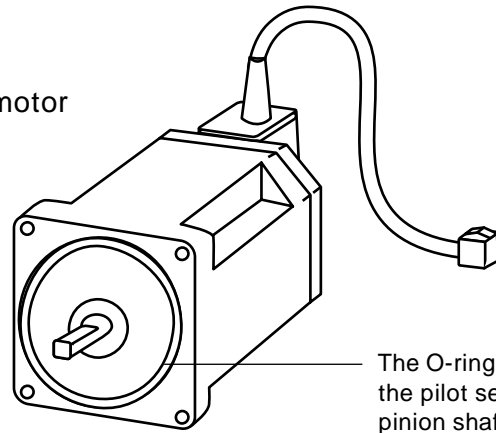

Accessories

Junction cable (1.6m)

A junction cable is not included with products which require an extension cable.



Driver mounting brackets (2pieces)



Mounting screws (4pieces)



External speed potentiometer

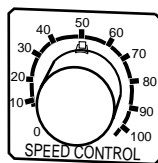

Signal line for connection to external speed controller (1m)

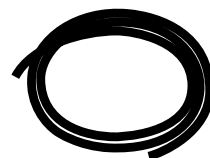

Manual (one piece)

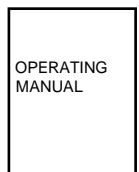

4. Mounting

4.1 Shipping

- (1) Do not ship with servomotor cable connected to the driver.
- (2) Do not drop, as this may cause damage.

4.2 Mounting the Motor

4.2.1 Direction of mounting

The motor can be installed either horizontally or vertically.

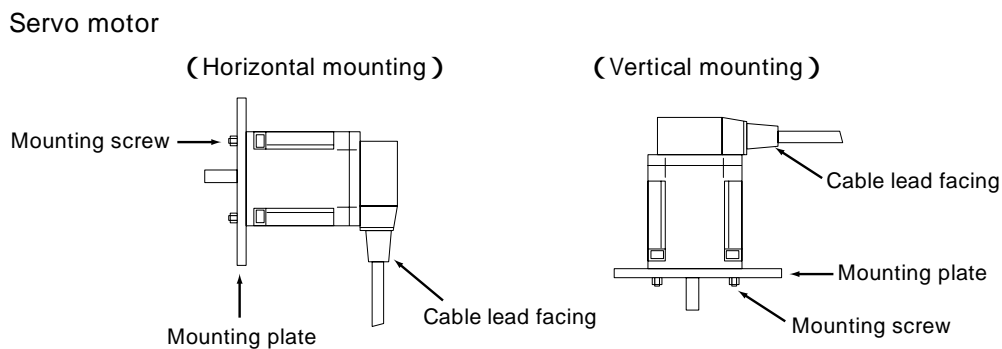

4.2.2 Attention when mounting

Ensure that the motor output shaft or the motor itself is not subjected to any impact. Impact to the motor may damage the optical encoder.



4.2.3 Installation conditions

These motors should only be installed in locations that meet the following environmental conditions. Using the product under conditions other than this could cause it to be damaged.

Indoors (this product is designed and manufactured to be installed within another device)

Ambient temperature from 0 ~ 40 (avoid freezing) .

Ambient humidity of 85% maximum (avoid condensation) .

Not exposed to explosive, flammable, or corrosive gases.

Not exposed to direct sunlight.

Not exposed to dust.

Not exposed to water or oil.

A place where heat can escape easily

Not exposed to continuous vibration or excessive impact.

4.2.4 Connection to Machinery

- When connecting the motor to machinery, the motor shaft must be aligned.
- When using a coupling for equipment attachment, select a product which can sufficiently absorb eccentricity and misalignment.

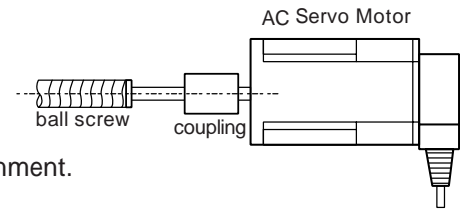

Notes

Misalignment of the motor shaft produces vibration which can greatly shorten bearing life and cause fatigue damage of the motor shaft.

4.3 Connecting Gearhead to the Motor

4.3.1 Attention when mounting

- Make sure the O-ring is attached firmly to the pilot section of the motor.
- Remove any particles of dust or other waste that may be clinging to the O-ring or the pilot section of the motor or gearhead.
- Do not pinch the O-ring when assembling the motor and gearhead.
Pinching or cutting the O-ring causes grease to leak from the gearhead.

4.3.2 Method for Mounting the Motor and Gearhead

- (1) Remove the felt plug from the pilot section of the gearhead.
- (2) Align the gearhead and motor as shown to the below, then engage the pinion section of the shaft to the gear gently by turning the gearhead slightly in both directions until the gearhead and motor fit flush together.

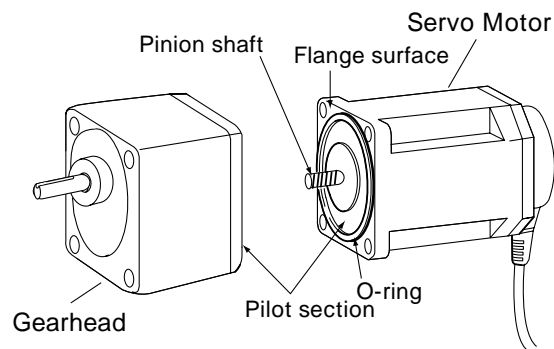

4.4 Mounting the Motor on Machinery

(1) Round shaft motors

Mount the motor securely on the machinery using bolts of suitable length, because the mounting screws is not included.

See table below for bolt sizes.

| Unit Model | Bolt Size |
|------------|-----------|
| KBL230- | M4 |
| KBL460- | M5 |
| KBL5120- | M6 |
| KBL6180- | M8 |
| KBL6400- | M8 |

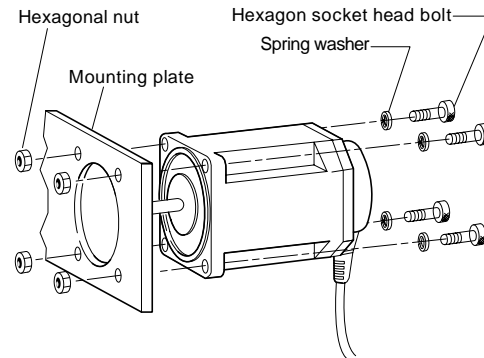

(2) Pinion shaft motors

After attaching the motor and gearhead, mount the unit on the machinery and secure tighten using the bolts included with the gearhead. Please refer to the GD or GH gearhead manual for details.

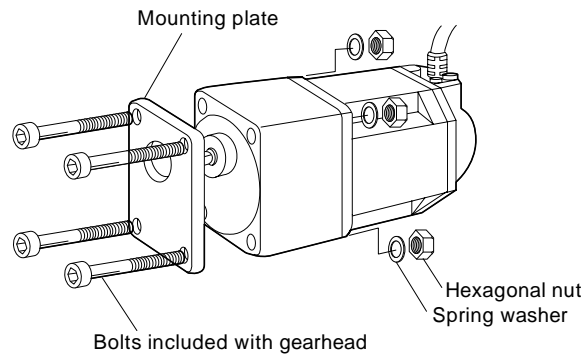

(2) Pinion shaft motors (RA -gearhead)

Before mounting the right angle gearhead to machinery, assemble the motor and the gearhead using the screws provided.

M8-size mounting screws for the equipment are not included in the pack and must be obtained separately. Please refer to the RA gearhead manual for details.

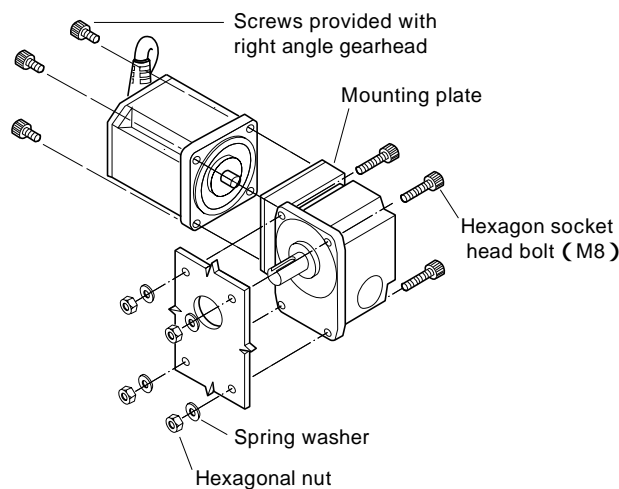

Notes

Use a strong mounting plate, fastening it securely to prevent vibration and good heat dissipation.

When continuously operating the servo motor by single phase 115V and 230V, an aluminum heat sink of 250mm × 250mm × 6mm, or larger compatible heat sink is necessary.

4.5 Installing the Driver

4.5.1 Installation Directions

It is necessary to install the servo-driver in an upright position, since the mechanism is cooled by means of natural convection current.

Use the accompanying mounting brackets and bolts. When mounting the driver directly onto machinery without using the mounting brackets, be sure to use screws of suitable length.

If the screws are too long, they could make contact with the driver's internal circuits, causing damage to the driver. (Mounting screws should be 2 ~ 3mm longer than the thickness of the mounting brackets.)

Also, to improve heat radiation, mount the driver vertically as shown in the figures below.

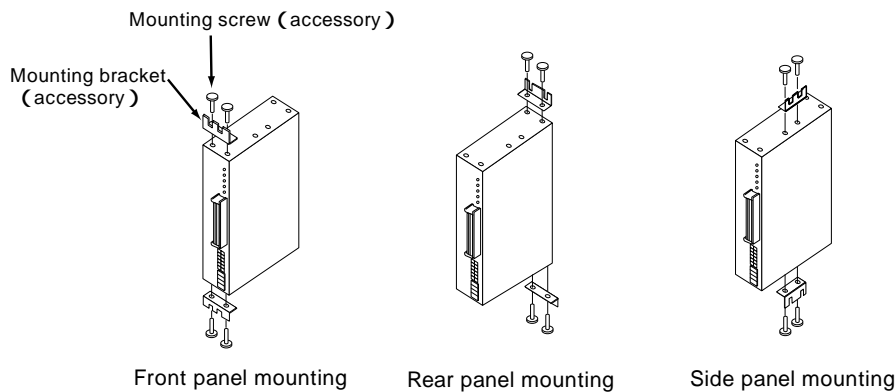

4.5.2 Installation conditions

These drivers should only be installed in locations that meet the following environmental conditions.

Indoors (this product is designed and manufactured to be installed within another device)

Ambient temperature from 0 ~ 40 (avoid freezing) .

Ambient humidity of 85% maximum (avoid condensation) .

Not exposed to explosive, flammable, or corrosive gases.

Not exposed to direct sunlight.

Not exposed to dust and pieces of conductive material (filings, pins, waste wire, etc.)

Not exposed to water or oil.

A place where heat can escape easily

Not exposed to continuous vibration or excessive impact.

Notes

- When installing the driver in a tightly sealed location such as a control panel or near a heat source, take precautions against driver temperature rise. When using in locations where the overheat protection function could activate, use a cooling fan or take other measures to keep ambient temperature below 40 .
- Use a shock absorber when installing the driver in locations where it could be subject to vibration.

4.5.3 Mounting Two or More Drivers

When installing several drivers in a row, leave a space of at least 20mm between each driver. Also, install drivers at least 25mm away from other devices or structures.

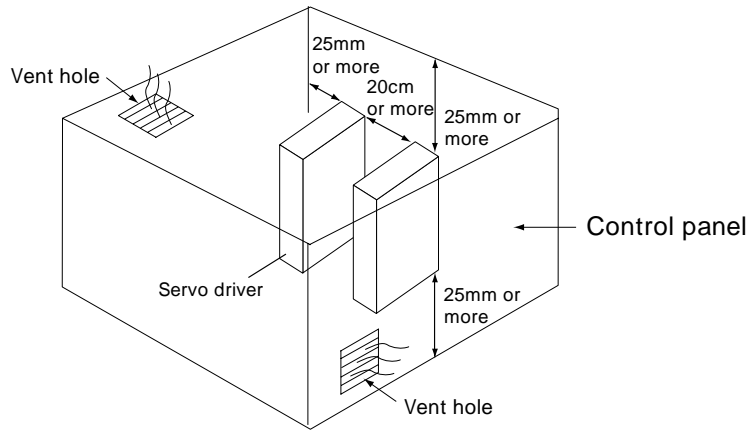

4.5.4 Mounting Plate Machining Dimensions (Unit : mm)

The mounting plate is not equipped with mounting screws. These must be purchased separately.

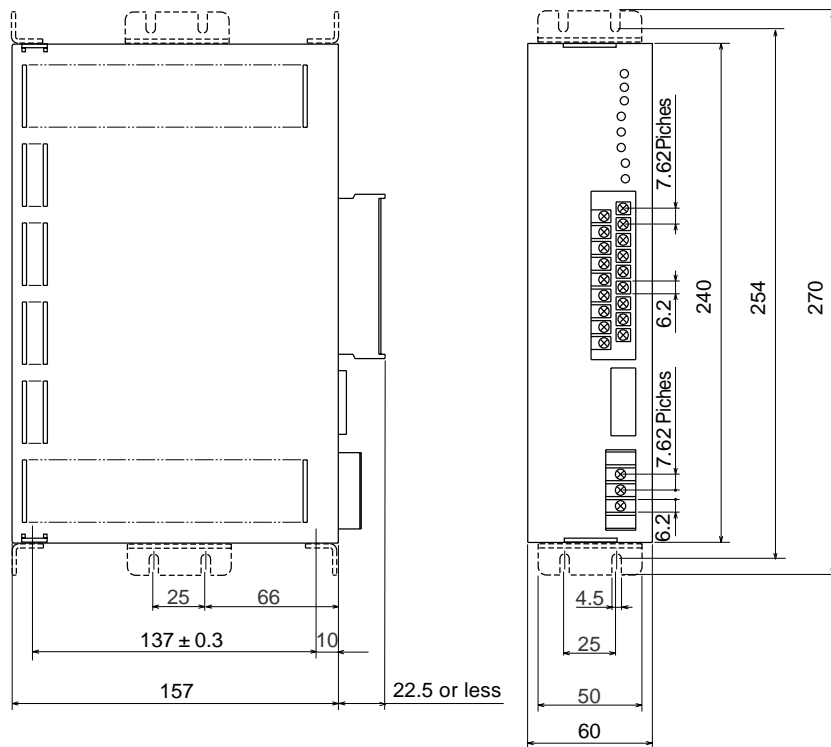

5. Connections

5.1 Before Connecting the Equipment

The following items are not included and must be provided by the customer.

- (1) Power supply cable
 - 3-Core cable (a conductor cross-sectional area of at least 1.25mm²)
- (2) Control I/O signal port
 - a multi-core, twisted-pair, blanket shielding cable, each 0.14mm or more in diameter

5.2 Connections

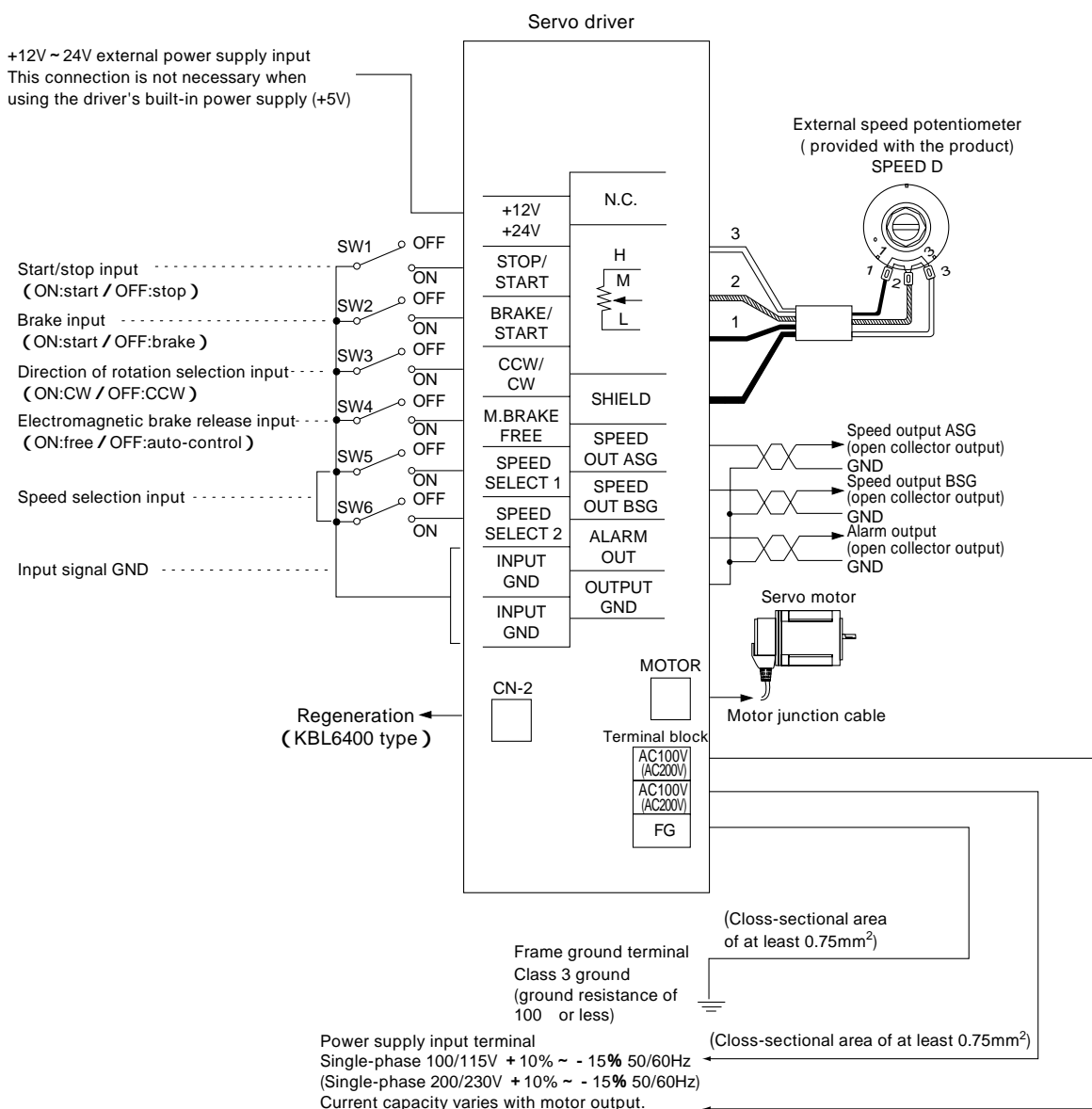

In addition to the switches shown in the diagram, input/output signal connections can be directly controlled by TTL or transistors.

For details, see the section "Input Signal Circuit" page .

5.3 Connecting the Motor and Driver (CN-1)

(1) Method for Connection

Servo motor cable is connected with junction cable connector provided.

Next, junction cable connector is connected with servo driver CN-1.

Confirm the motor side and the driver side of connector referring to dimensions of the junction cable.

(Page 46)

(2) Cable included models are provided with 1.6m of junction cable.

If you wish to extend the cable, please purchase junction cable (sold separately) in the length you require.

See Page 46 for dimensions.

Extension Cable
(cable for standard type)

| Cable Model | L(m) |
|-------------|------|
| CC01SKF | 1 |
| CC016SKF | 1.6 |
| CC03SKF | 3 |
| CC05SKF | 5 |
| CC07SKF | 7 |
| CC10SKF | 10 |
| CC15SKF | 15 |
| CC20SKF | 20 |

Extension Cable
(for models equipped with electromagnetic brake)

| Cable Model | L (m) |
|-------------|---------|
| CC01SKFM | 1 |
| CC016SKFM | 1.6 |
| CC03SKFM | 3 |
| CC05SKFM | 5 |
| CC07SKFM | 7 |
| CC10SKFM | 10 |
| CC15SKFM | 15 |
| CC20SKFM | 20 |

The extension cable are not designed to be bent. For applications in which the motor is mounted on a movable device and the cable repeatedly bent and straightened out, use the optional flexible cable CC SKR (for standard type) , CC SKRM (for electromagnetic brake type) .

5.4 Connecting the Driver and Power Supply

5.4.1 Method for Connection

Release the servodriver's terminal block covers, and connect.

After doing so, re-fit the terminal block cover as a safety measure.

Power supply voltage : Single phase 100/115V + 10% ~ - 15% 50/60Hz

: Single phase 200/230V + 10% ~ - 15% 50/60Hz

The servodriver's maximum current input depends on the type of servomotor, and on output.

Please consult the specification charts on page 30 ~ 31 for the capacity required.

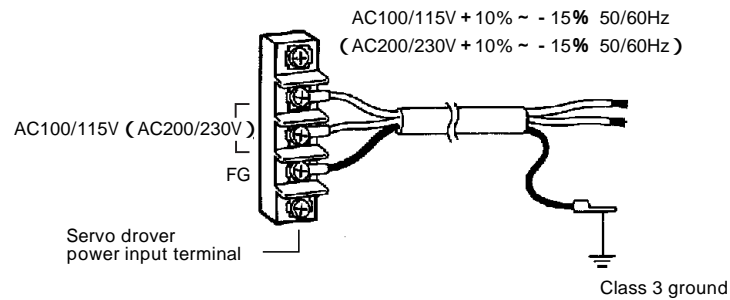

5.4.2 Crimp Terminals

For the connection to the terminal block, use a insulated round-shape crimp terminal or insulated U-shape crimp terminal. The terminal block screws are size M3.

Round terminal with insulation

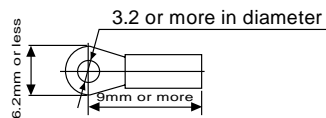

- V1.25-3 (Japan Crimp Terminal Co.)
- 1.25-3TA(B) (Japan Terminal Co.)
Equivalent product

U-shape terminal with insulation

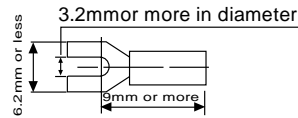

- AV1.25N3A (Japan Crimp Terminal Co.)
- VD1.25-3TA(B) (Japan Terminal Co.)
Equivalent product

5.5 Noise Suppression, Grounding method

Excessive noise entering the servo-system from outside can lead to operational errors. By taking measures such those described below, trouble due to noise can be prevented.

5.5.1 Noise Suppression

- For the wiring between the servo motor and servo driver, use either the accompanying junction cable or the available extension cable.
- Keep the signal line as short as possible.
- Keep the signal line at least 30cm away from cables carrying large current. Do not run the cable through the same duct or pipe with cables which carry large current or which could otherwise be a source of noise.
- When setting speed by means of the external speed potentiometer or a DC voltage, use the signal line provided with the unit.
- In situations where drivers are located close to a large noise source such as high frequency welding machines or large electromagnetic switches, take steps to prevent noise interference, either by inserting noise filters or connecting the driver to a separate circuit.

5.5.2 Grounding method

- The FG terminal on the servo driver should be grounded with a type 3 earth or better (100 or less) using a cable with a conductive cross section of 0.75mm² or better. The earth should also be a one-point earth.
- The servomotor should be earthed on a metal plate using AWG18 (0.75mm² or better) . However, if a GD or GH gearhead is use, an earth is not possible because the mounting surface is painted. Make an earth connection by peeling the paint off the screws.

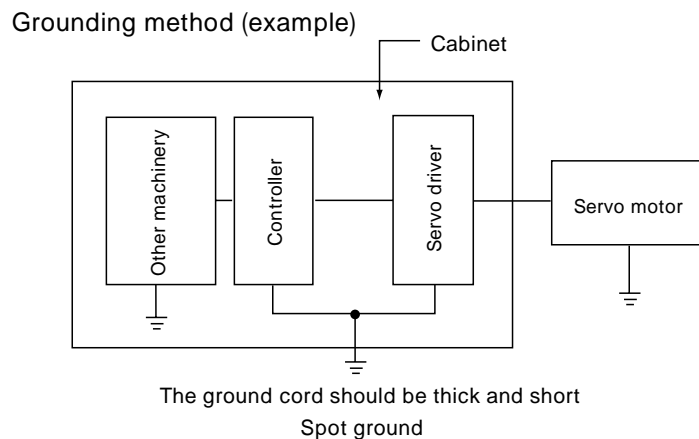

5.6 Installation of the leakage breakers

With AC servo motors, a high frequency switching current flows in the capacitor of the power supply input's noise filter and in the motor windings, and a floating capacitance exists between the windings and the case. This current and capacitance generate a high frequency leakage current.

Therefore, use a leakage breaker with protection against high harmonics in order to prevent faulty operation.

| | | |
|--|--------------------------------------|---------------------------|
| Recommended leakage breakers (with protection against high harmonics) | Mitsubishi Electric Fuji Electric | NV Series EG、SG Series |
|--|--------------------------------------|---------------------------|

5.7 Methods of Speed Setting and Their Connection

The method of connecting and selecting these speed control devices is described in the following three sections.

- (1) Built-in speed potentiometers
- (2) External speed potentiometer
- (3) External DC power supply

Speed can be controlled using the SPEED A, B, C built-in speed potentiometers or the SPEED D external speed potentiometer. The A, B, C built-in speed potentiometers and the D external speed potentiometer can be selected by means of the SPEED SELECT signal input as shown in the table below.

Acceleration and deceleration when changing motor speed varies depending on the acceleration and deceleration time settings.

| Speed Selection Input | | Speed Potentiometer Selected | Speed Control Range |
|-----------------------|----------------------|------------------------------|---------------------|
| SPEED SELECT 1 (SW5) | SPEED SELECT 2 (SW6) | | |
| OFF | OFF | SPEED A (built-in) | 30 ~ 3000r/min |
| ON | OFF | SPEED B (built-in) | 30 ~ 3000r/min |
| OFF | ON | SPEED C (built-in) | 30 ~ 3000r/min |
| ON | ON | SPEED D (external) | 30 ~ 3000r/min |

5.7.2 Connecting and setting the built-in speed potentiometers

When using only the built-in speed potentiometers, it is not necessary to make connections to the H, M, L and SHIELD terminals. When making minute adjustments in speed, it is more effective to use the built-in speed potentiometer.

With the built-in speed potentiometers, speed is increased or decreased by turning the dials to HIGH or LOW.

When the lowest setting (0 r/min, set at shipment) or highest setting (3000 r/min motor shaft speed) is reached, the dial begins to make a slight clicking sound. Although it is possible to continue turning the dial in the same direction at this time, the setting remains the same.

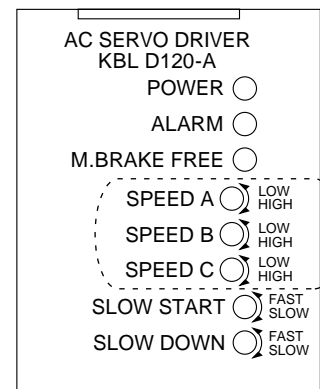

5.7.2 Connecting and setting the external speed potentiometer

The angle of rotation of the accompanying external speed potentiometer is about 300 ° .

When making minute adjustments in speed, it is more effective to use the built-in speed potentiometer.

(1) Connecting the External Speed Potentiometer

The accompanying external speed potentiometer is used when controlling motor speed from a position located at some distance from the driver.

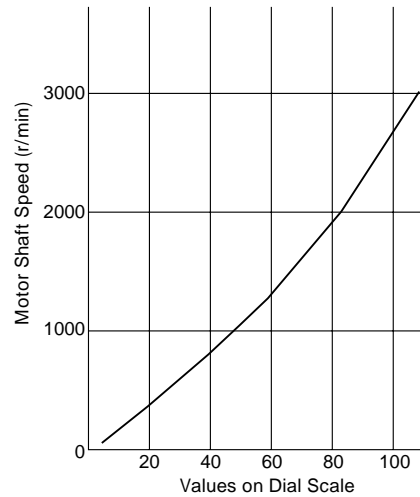
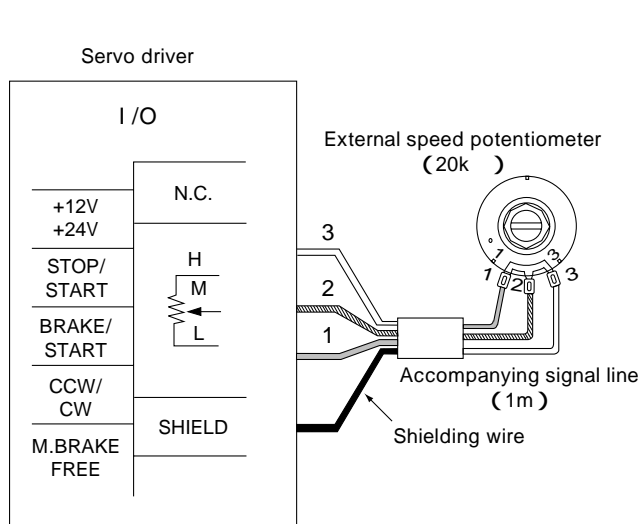

Correspondence Between Dial Setting and Motor Speed

To select this method, connect the controller as shown in the diagram above, and set SPEED SELECT 1 (SW5) and SPEED SELECT 2 (SW6) to ON.

(2) Connecting the External DC Power Supply

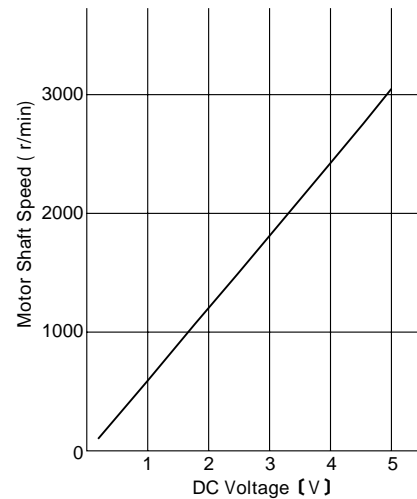
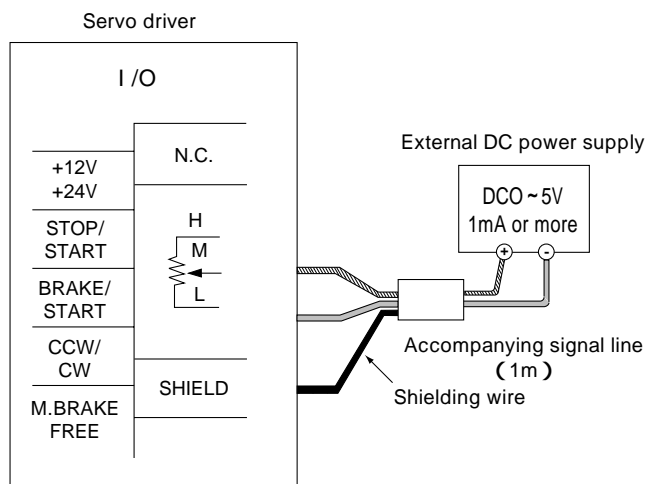

Correspondence Between DC Voltage and Motor Speed

Speed can also be controlled by means of an external DC voltage. To select this method, connect the power supply as shown above, and set SPEED SELECT 1 (SW5) and SPEED SELECT 2 (SW6) to ON.

Note

Always use the accompanying signal line (3.3mm external diameter × 1m) when controlling speed by means of the external speed potentiometer or external DC voltage. The signal line's shielding wire should be connected to the SHIELD terminal. Be sure that this shielding wire is not connected to any other terminal on the external speed potentiometer or DC power supply. The input impedance between the M terminal and the L terminal is about 20k . The L terminal is connected internally to the INPUT GND.

6. Function • Operation

6.1 Control Input Output Circuits (I/O)

6.1.1 Input Circuit

Control signals are input by photocoupler as shown in the figure below.

The photocoupler for the control input section can be driven by the built-in power supply (DC5V) or by an external DC power supply (DC12 ~ 24V) .

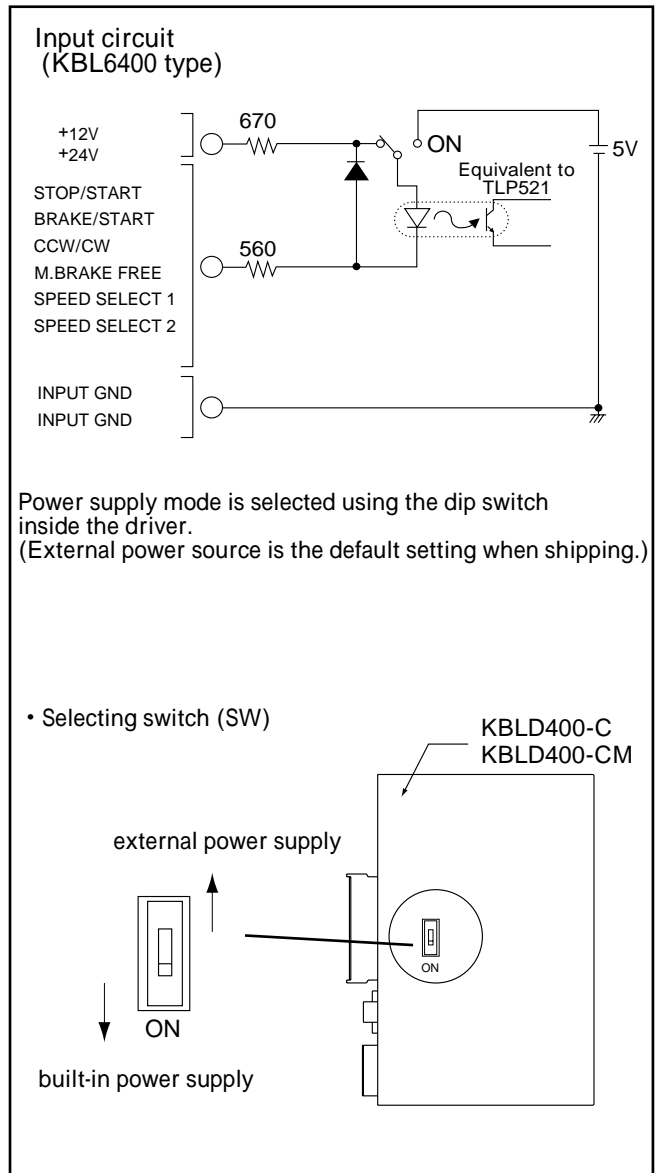
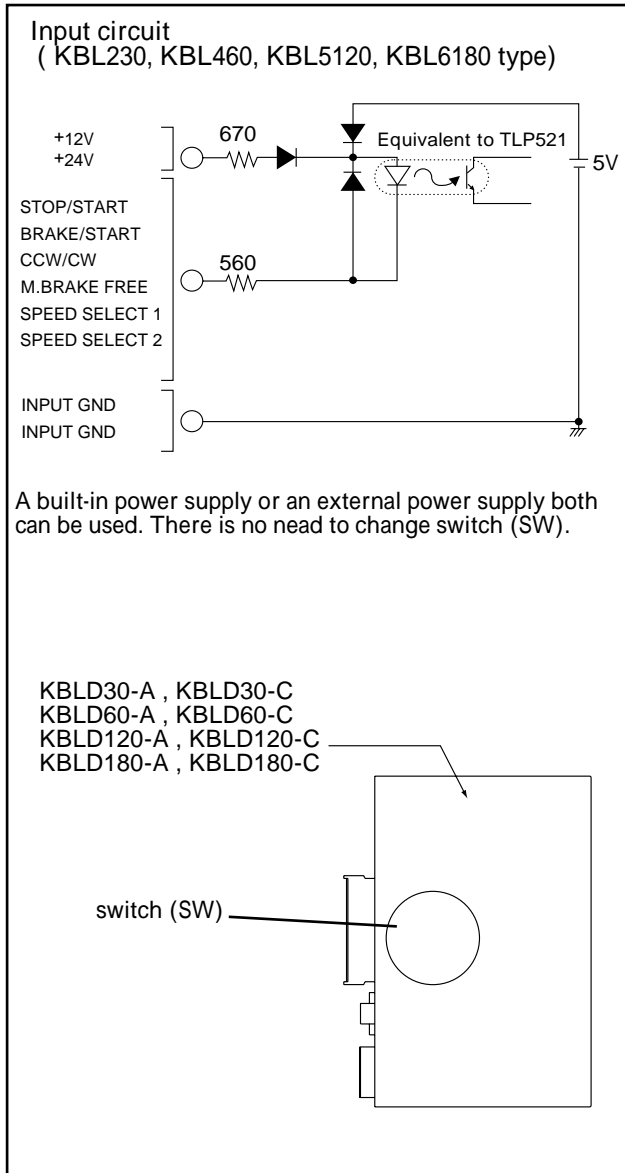

Notes

When switching between the on-board input signal power source and the external power source on the KBL6400 model, ensure that the power sources are in the OFF position first.

6.1.2 Output Circuit

As shown in the diagram at right, signals are output by means of an open collector, which requires an external power supply.

This power supply should be DC26.4V or less.

Also, connect a resistance suitable for the power supply voltage so that current does not exceed 20mA.

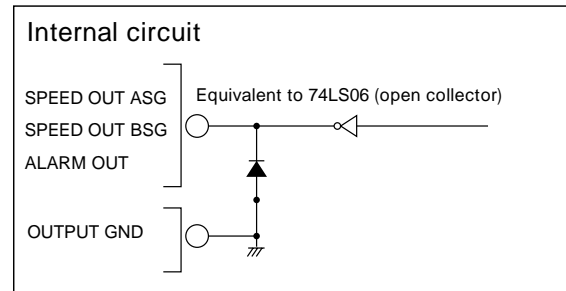

(1) Speed Output

Speed signals are output at a rate of 400 pulses per motor revolution and at a frequency (pulse signals) corresponding to motor speed. There is a phase lag between output of ASG and BSG signals of 90 ° electrical degrees.

Motor speed and speed output frequency are related as shown in the following expression :

$$\text{Motor speed} = \frac{\text{Speed output frequency (Hz)}}{400} \times 60 \text{ (r/min)}$$

Use the XDM4000 speed meter (the SDM496 cannot be used) .

We supply an original equipment speed indicator XDM4000 for this product.

For further information, contact your nearest Oriental Motor sales office.

(2) Alarm Output (negative logic output)

This signal indicates that one of the driver's protection functions has been activated. When an abnormality such as an overload or overvoltage is detected, the alarm signal is output, the ALARM LED lights, and the motor stops. In electromagnetic brake models, the brake stops the motor instantaneously if the brake is being controlled automatically.

6.2 Input Signal Circuit

The diagrams below show suitable connections for the following input signals: STOP/START, BRAKE/START, CCW/CW, M.BRAKE FREE, SPEED SELECT 1 and SPEED SELECT 2.

(1) When using the driver's built-in power supply

(2) When using an external DC power supply

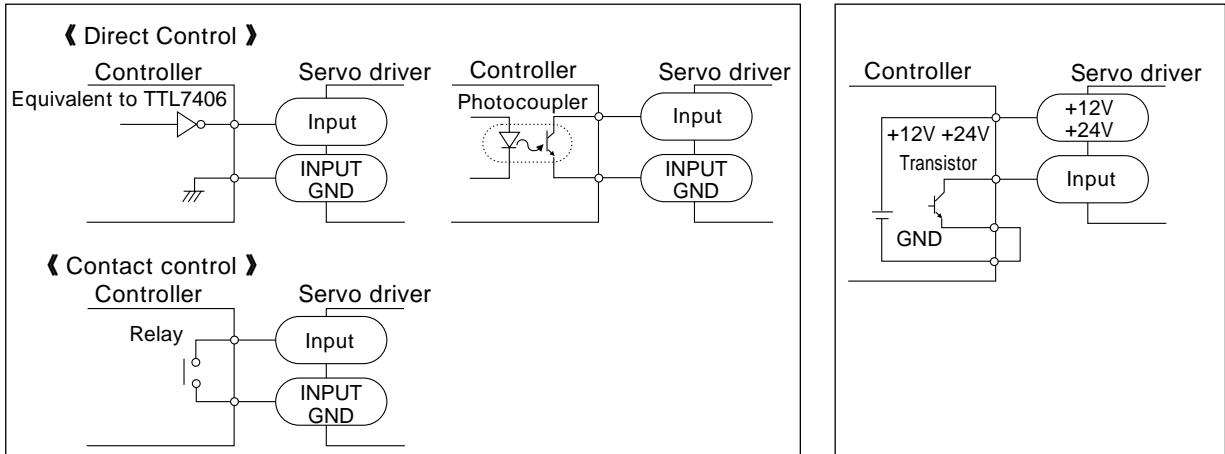

(3) Cautions to observe when using a controller with an internal clamp diode

When using a wiring configuration as illustrated in this diagram, turning on the driver first at start-up or turning off the controller when the driver is still on may cause current to flow as indicated by the arrows in the diagram, thereby causing the motor to run.

Differences in power supply capacity may cause the motor to run temporarily when the driver and controller are turned on or off simultaneously. Therefore, always turn the controller on first and the driver off first.

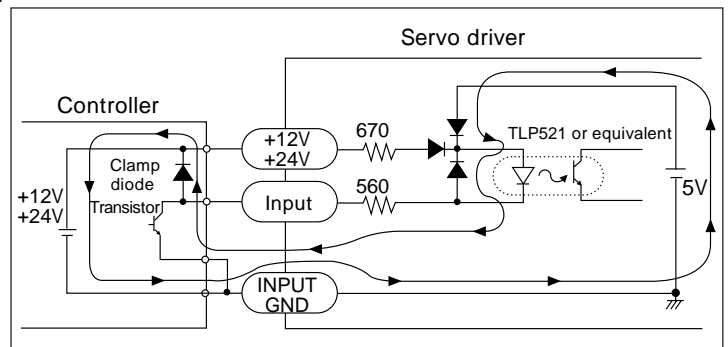

ON : Turn the controller on first, then turn on the driver.
 OFF : Turn the driver off first, then turn off the controller.

This phenomenon will not occur when using the external power source on the KBL6400 model.

6.3 Output Signal Circuit

The following diagram shows a connection suitable for the following output signals :
 SPEED OUT ASG, SPEED OUT BSG, ALARM OUT.

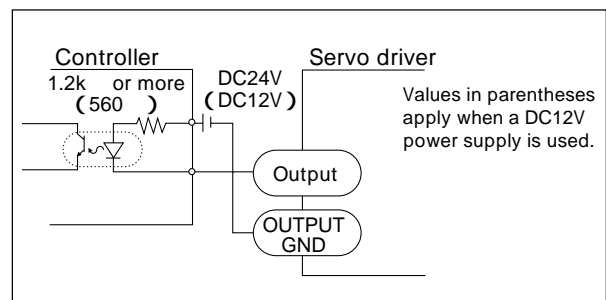

6.4 Operation Timing Charts

In the examples given in the diagrams below, the built-in speed potentiometers (SPEED A, B, C) and the external speed potentiometer (SPEED D), have been set to 3000r/min, 2000r/min, 1000r/min and 100r/min, respectively, allowing four speed levels to be selected.

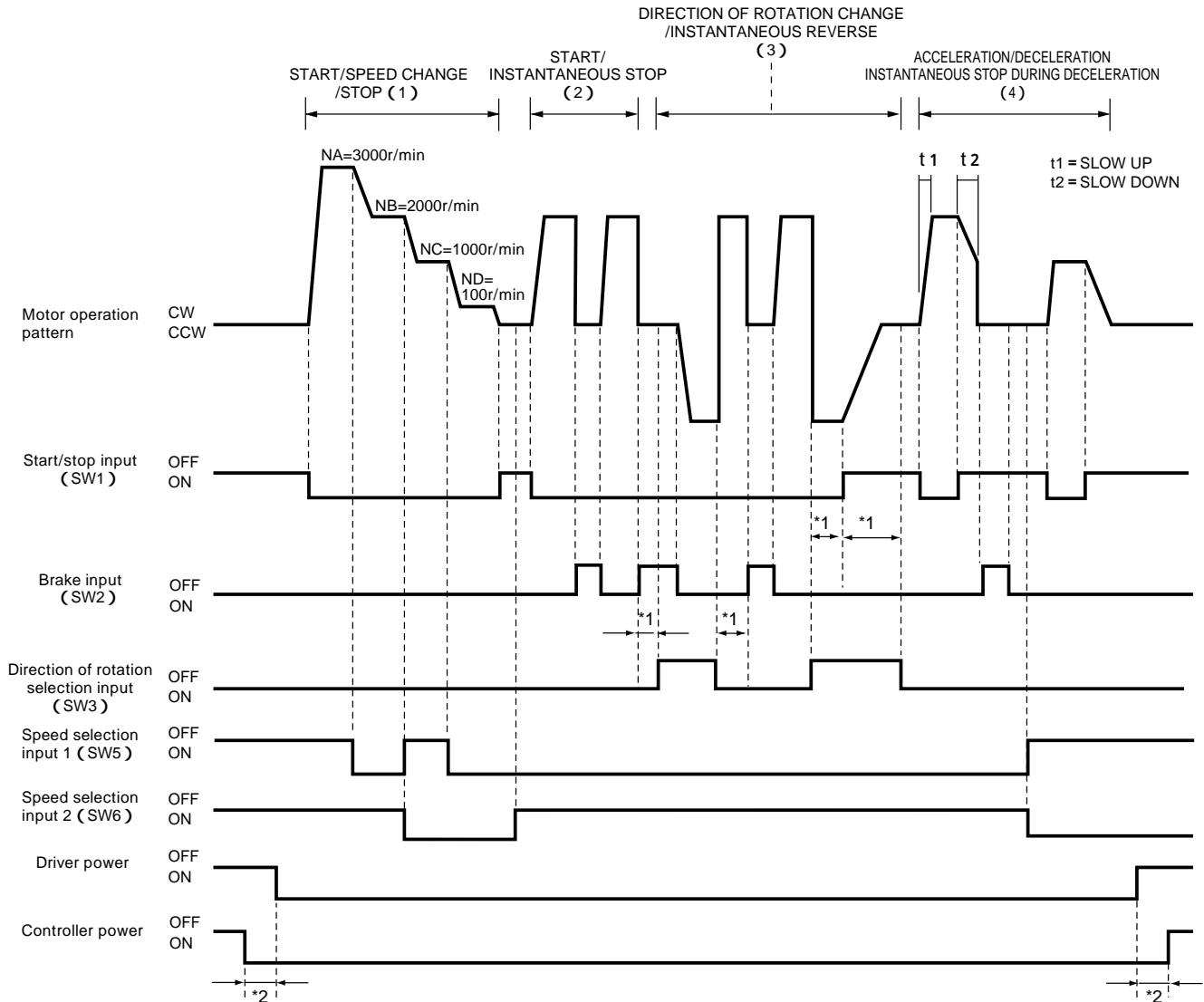

*1 Five seconds or more is sufficient.

*2 Five seconds or more is generally sufficient, but this time interval may differ depending on the type of power supply and actual use conditions.

Adjust the time interval in accordance with actual use conditions.

Note

- For sure braking, wait at least 0.5 seconds when switching between direction of rotation selection input and brake input and between direction of rotation selection input and start/stop input. Brake may not activate when switching within 0.5 seconds.
- When using a controller (programmable controller, etc.) with an internal clamp diode, turn the controller on first and turn the driver off first.
- Reversing the power on/off order may cause the motor to rotate temporarily when the power supply is turned on or off.

6.4.1 Motor Start and Stop

(1) Servo Motor Start

When the brake input SW2 is switched to ON with the start/stop input SW1, the motor accelerates up to the set speed for the duration set as the acceleration time.

When the start/stop input SW1 is switched to ON with the brake input SW2, the motor accelerates up to the set speed for the duration set as the acceleration time.

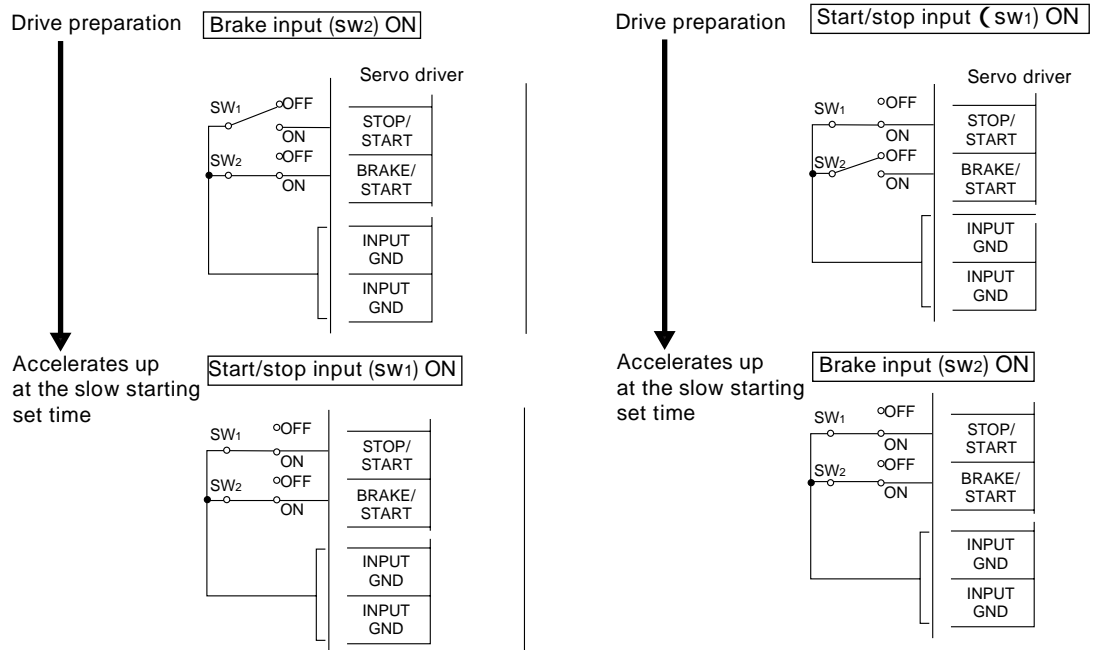

(2) Servo Motor Stop

When SW2 is switched to OFF, the motor stops instantaneously regardless of the deceleration time set. When significant overrun occurs even when the brake is used to come to a halt, consider reducing the inert load or decelerating to minimal speed before stopping.

The servomotor can be brought to a slow down and stopped by switching the Start/Stop switch from SW1 to OFF.

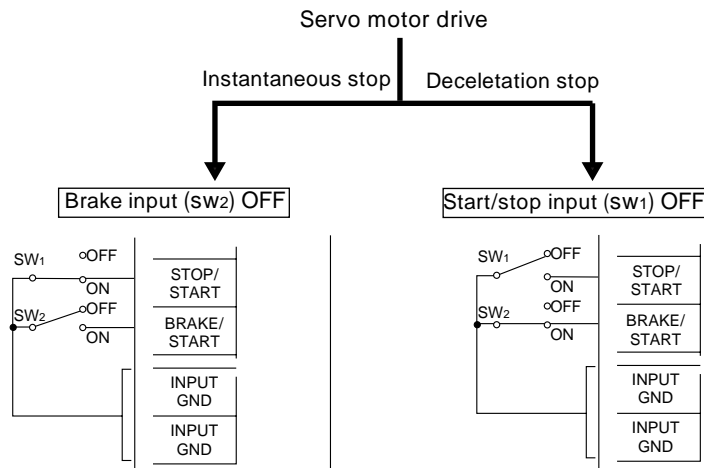

6.4.2 Acceleration, Deceleration and Instantaneous Stops during Deceleration

If the start/stop input SW1 is switched to ON with the brake input SW2 set to ON, the motor slowly accelerates up to the set speed. If SW1 is switched to OFF, the motor slowly decelerates to a stop. Acceleration and deceleration at these times varies linearly.

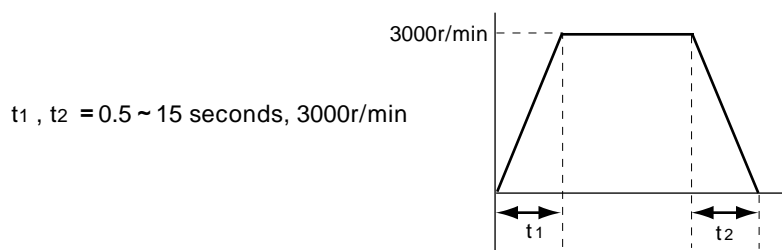

$t_1, t_2 = 0.5 \sim 15$ seconds, 3000r/min

The duration of acceleration and deceleration operation is set by means of the built-in time setting potentiometer for each.

The duration of acceleration or deceleration can be shortened by turning the dial to FAST, lengthened by turning the dial to SLOW.

The angle of rotation is about 270° .

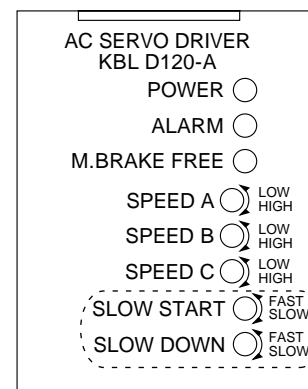

When using an external DC power supply to control speed, control can be performed by means of the start/stop input. If SW2 is switched to OFF after setting SW1 to OFF, the motor stops instantaneously. (Always set SW2 to ON when starting the motor.)

6.4.3 Changing the Motor's Direction of Rotation

The motor's direction of rotation can be reversed instantaneously by means of the direction of rotation selection input SW3.

The motor rotates clockwise (CW) when SW3 is switched to ON, counterclockwise (CCW) when SW3 is switched to OFF (direction of rotation when viewed facing the motor shaft).

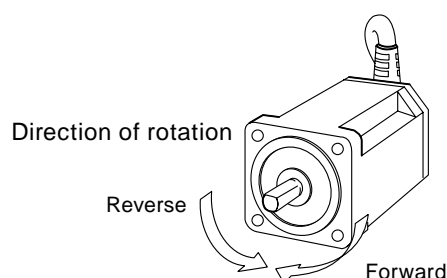

Note

When using the motor with a gearhead, certain reduction gear ratios will cause the gearhead output shaft to rotate in the opposite direction of the motor shaft. For details, see page 33.

6.4.4 Changing Motor Speed

Motor speed can be changed by setting the speed selection inputs as shown in the table below to select the A, B or C built-in speed potentiometer or the D external speed potentiometer. When changing speeds, acceleration and deceleration will vary depending on the time set for acceleration and deceleration operation.

| Speed Selection Input | | Speed Potentiometer Selected | Speed Control Range |
|-----------------------|----------------------|------------------------------|---------------------|
| SPEED SELECT 1 (SW5) | SPEED SELECT 2 (SW6) | | |
| OFF | OFF | SPEED A (built-in) | 30 ~ 3000r/min |
| ON | OFF | SPEED B (built-in) | 30 ~ 3000r/min |
| OFF | ON | SPEED C (built-in) | 30 ~ 3000r/min |
| ON | ON | SPEED D (external) | 30 ~ 3000r/min |

6.5 Use of the Electromagnetic Brake (Electromagnetic brake models)

6.5.1 Type of Electromagnetic brake

Electromagnetic brakes incorporated in KBLII series motors are non-excitation type brakes ; that is, they engage when power is not being input and disengage when it is, at which time the motor shaft is released .

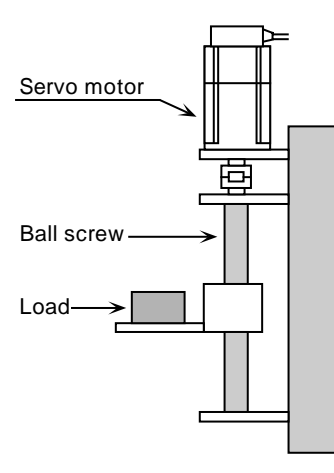

6.5.2 Connection of Electromagnetic brake

When the motor cable is connected, an electromagnetic brake is controlled automatically.

6.5.3 Automatic control

When the electromagnetic brake release input (SW4) is " OFF " , the electromagnetic brake is automatically controlled according to the start/stop input or the brake input signal.

The electromagnetic brake operates when the speed becomes less than 30 r/min.

When the motor is stopped, the electromagnetic brake operates until the electromagnetic brake release input is turned " ON " .

In addition, the motor shaft locks when the ALARM indication lights.

6.5.4 Releasing the Electromagnetic Brake

Switching the electromagnetic brake release input SW4 to ON releases the electromagnetic brake and allows the motor shaft to be turned manually. This input signal can be used before operation to release the motor shaft for setting position and the like.

However, caution is required when using SW4 : if it is switched to ON while applying a load that could turn the motor shaft, the motor will not be able to hold the position of load.

Notes

- The electromagnetic brake is used to hold position of a load. It cannot be used for braking.
- The electromagnetic brake incorporated into the electromagnetic brake models is not a stopping mechanism to ensure mechanical safety.

To ensure mechanical safety, incorporate a stopping mechanism into your equipment.

6.6 Multi-Motor Control Function

The figures below give the wiring configurations for operating two or more motors at the same speed using a single DC power supply or external speed potentiometer.

(1) When using a DC power supply

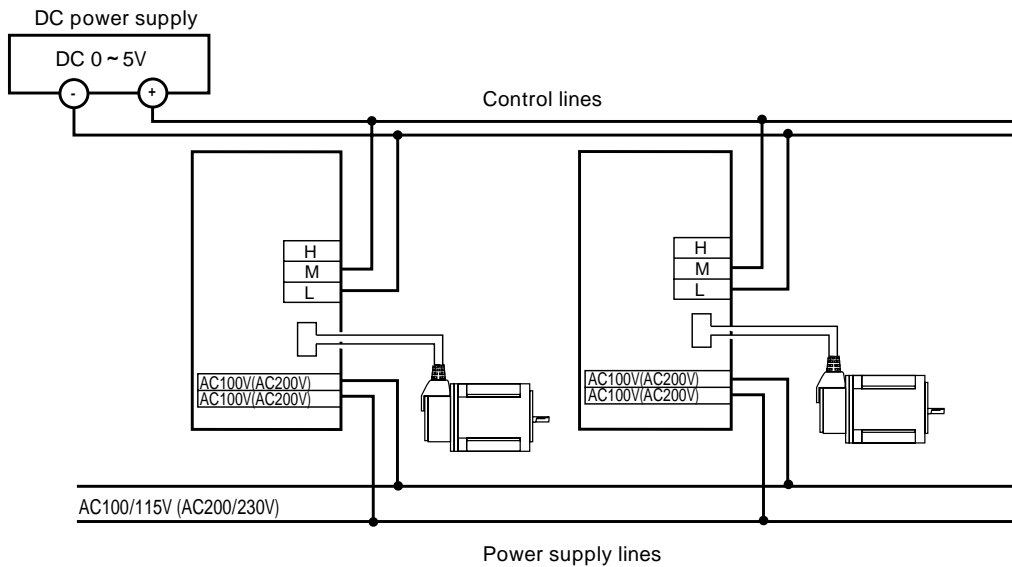

Notes

- Use a DC power supply with a current capacity greater than or equal to that given by the following expression :
 $I = I \times N$ (mA) (where N is the number of motors) .
 Example : When two motors are operated, the current capacity is 2mA.
- All other input/output signal terminals should be set separately for each motor.

(2) When using an external speed potentiometer

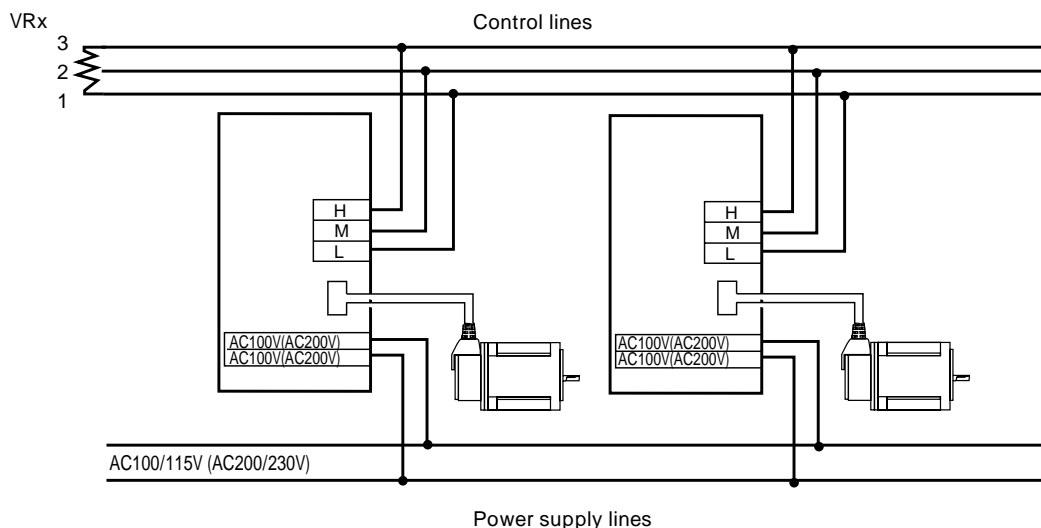

Notes

- Connect separate control line to the H, M and L terminals.
- The resistance of the speed potentiometer is given by the following expression :

$$VRX = \frac{20}{N} \text{ (K } \Omega \text{) (where N is the number of motors)}$$

Example : When two motors are operated, the resistance is 10k Ω • 1/4W.

- All other input/output signal terminals should be set separately for each motor.

6.7 Protection Functions

KBLII Series motors are equipped with various protection functions to ensure safety when abnormalities arise in operating conditions or in the motor system. When a protection function is activated, the motor enters a non-excitation (free) state ; at the same time, an alarm signal is output, the LED on the driver's front panel lights, and the motor stops naturally. (In electromagnetic brake models, the motor is stopped instantaneously by the electromagnetic brake if the brake is being controlled automatically.)

When an alarm signal is output, turn off power, correct the problem which caused the alarm, and turn power back on.

| Protection Function | When Activated |
|---------------------|--|
| Overload | Activated when a load exceeding the rated torque is applied to the motor for 5 seconds or more. |
| Overheat | Activated when the temperature of the driver's internal radiator exceeds 80 °C due to operation involving frequent starts and stops or reversals using a short operating cycle, or when using the motor for lowering operations. The alarm can be reset when the temperature of the internal radiator falls below 72 °C. |
| Overvoltage | Activated when the inverter's primary voltage exceeds the permissible value as a result of an excessive load being applied during lowering operations or the like. |

Notes

The protect function will not be effective while using a gearhead if a load in excess of the rating torque is not exerted on the servo motor output shaft even if the load is greater than the permissible gearhead torque.

Refer to a permissible torque when the gear head is connected directly when you use the gear head.

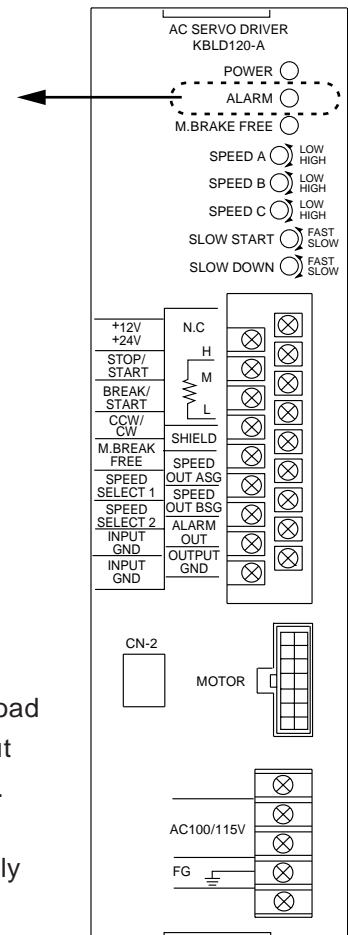

7. Troubleshooting

If the motor fails to function properly, first check to see that the problem is not due to errors in operation or set-up as described in the table below. If the trouble persists, contact your nearest Oriental Motor.

| Problem | Check Point | Response |
|------------------------|--|---|
| Motor does not rotate. | Is the driver correctly wired to the power supply ? | Correct wiring and check that the POWER LED is lit. |
| | Is the motor connector correctly inserted ? | Recheck this connection. |
| | Is START / STOP input set to START ? Is BRAKE / START input set to START ? | Set both of these inputs to START. If one is set to STOP or BRAKE, the motor will not rotate. |
| | Is the dial of the speed potentiometer turned all the way to the left ? | Turn the dial of the speed controller to the right to increase speed. |
| | Is an alarm signal being output ? Correct the | problem which caused the alarm. Then turn off power, wait 10 seconds, and turn power back on. The motor will be restored to the state immediately preceding alarm output. |
| | Is wiring to the speed selection input correct ? | Check to see if the speed potentiometer in use has been selected correctly. |
| | Is GND for the input signal connected? Recheck this connection. | |
| Speed does not change. | Is the external potentiometer correctly inserted ? (When using an external potentiometer) | Recheck this connection. |
| | Is wiring to the speed selection input correct ? | Check to see if the speed potentiometer in use has been selected correctly. |
| | If an external DC power supply is being used, are the plus and minus signal lines connected to the correct terminals ? | Connect the minus line to the L terminal and the plus line to the M terminal. |

| Problem | Check Points | Response |
|--|---|--|
| Motor rotates in opposite direction. | Is a gearhead being used? Certain gearheads | reduction gear ratios cause the output shaft to turn in the opposite direction of the motor. |
| Start is delayed. | Is the dial of the acceleration time setting potentiometer turned to SLOW? | Turn the acceleration time setting potentiometer to FAST. |
| Stop is delayed. | Is the dial of the deceleration time setting potentiometer turned to SLOW? | Switch BRAKE / START input to BRAKE to stop the motor, or turn the deceleration time setting potentiometer to FAST. |
| | Is the direction of rotation being changed at the same time as input of BRAKE or STOP signals? | An interval of 0.5 seconds or more should be allowed between selection of CW / CCW and input of BRAKE or STOP signals, otherwise the brake may not engage. |
| Motor does not rotate smoothly. | Is the motor's speed setting less than 30 r/min? | Set the motor's speed within the range 30 (3000r/min) |
| Alarm is output. | Is there an overload? Recheck the load and | ensure that the motor is being operated below the rated torque and permissible inertial load. |
| | Is ambient temperature above 40 °C? Either | cool the motor or reduce ambient temperature. |
| | Before the set speed has been reached, has the direction of rotation been reversed changes of direction or repeated starts and stops at short cycles? | Take action such as increasing the length of the operating cycle or reducing the inertial load. |
| | Is the unwinding output greater than 30W (100W for KBL6400)? | Take action such as reducing the speed of lowering operation or lengthening the duration of stops. |
| The motor start rotating when the power is turned on or off. | Are you using a controller with an internal clamp diode? | When using a controller with an internal clamp diode, turn the controller on first and the driver off first. |
| No output signal. | Is the output signal correctly inserted? Recheck this connection. | |
| | Do the external power voltage and output current meet the specifications? | Review the output circuits so that the output current is 20mA or less using an external power source of 26.4V or less. |
| An abnormal sound is heard | Is the motor shaft properly aligned with the other machine? | Set the alignment to the specified values for the coupling or less. |

8. Specifications

8.1 AC Servo motor/Servo driver Specifications

(1) Standard Models These specifications are applicable when the driver is used in combination with a servo-motor.

| | | | | | | | |
|-------------------------------|--|---|---|---------------------------------|--------------------------------|---------------------------------|-----------------|
| Unit Model | Round shaft type | 100V | KBL230-A2 | KBL460-A2 | KBL5120-A2 | KBL6180-A2 | - |
| | | 200V | KBL230-C | KBL460-C | KBL5120-C | KBL6180-C | KBL6400-C |
| Pinion shaft type | 100V | KBL230GD-A2 | KBL460GD-A2 | KBL5120GD-A2 | KBL6180GD-A2 | - | |
| | 200V | KBL230GD-C | KBL460GD-C | KBL5120GD-C | KBL6180GD-C | KBL6400GH-C | |
| Motor's Rated Output | [W] | 30 | 60 | 120 | 180 | 400 | |
| Rated Speed | [r/min] | 3000 | | | | | |
| Rated Torque *1 | [N · m] | 0.1 | 0.2 | 0.4 | 0.6 | 1.3 | |
| | ([kgcm]) | (1.0) | (2.0) | (4.0) | (6.0) | (13.0) | |
| Peak Torque *2 | [N · m] | 0.2 | 0.4 | 0.8 | 1.2 | 2.6 | |
| | ([kgcm]) | (2.0) | (4.0) | (8.0) | (12.0) | (26.0) | |
| Speed Control Range | [r/min] | 30 ~ 3000 | | | | | |
| Acceleration/Deceleration | | 0.5 sec ~ 15sec (3000 r/min) | | | | | |
| | Relative to load | - 0.1% (3000r/min at rated torque) | | | | | |
| Speed fluctuation ratio | Relative to voltage | ± 0.1% (single-phase 100V / 115V + 10% ~ - 15%、 single-phase 200V/230V + 10% ~ - 15%、 3000 r/min, with no load applied) | | | | | |
| | Relative to temperature | ± 0.5% (0 ~ + 40 °C, 3000r/min, with no load applied) | | | | | |
| Rotor Inertial Moment | J [kgm ²] | 1.1 × 10 ⁻⁵ | 5.7 × 10 ⁻⁵ | 1.1 × 10 ⁻⁴ | 1.7 × 10 ⁻⁴ | 1.15 × 10 ⁻⁴ | |
| | (GD ² [kgcm ²]) | (0.45) | (2.3) | (4.5) | (7.0) | (4.6) | |
| Suitable Load Inertial Moment | J [kgm ²] | 5.7 × 10 ⁻⁵ or less | 2.87 × 10 ⁻⁴ or less | 5.62 × 10 ⁻⁴ or less | 8.7 × 10 ⁻⁴ or less | 17.5 × 10 ⁻⁴ or less | |
| | (GD ² [kgcm ²]) | (2.3 or less) | (11.5 or less) | (22.5 or less) | (35 or less) | (70 or less) | |
| Power supply Input | Voltage and Frequency | 100V | single-phase 100/115V + 10% ~ - 15% 50/60Hz | | | | |
| | | 200V | single-phase 200/230V + 10% ~ - 15% 50/60Hz | | | | |
| Maximum Input Current | 100V | 3.4A | 4.8A | 7.5A | 10.5A | - | |
| | 200V | 2.5A | 3.1A | 4.3A | 5.8A | 11A | |
| Motor's Insulation Class | | Class E (120 °C) | | | | | ClassB (130 °C) |
| Control System | | FET Rectangular wave PWM control | | | | | |
| Speed Detection System | | Optical Encoder (400P/R) | | | | | |
| Speed Control Command | | By one of the following : <ul style="list-style-type: none"> • Internal speed potentiometers (3) • External speed potentiometer (20k Ω, 1/4W) • DC voltage control (DC0 ~ 5V) | | | | | |
| Input signals | | Photocoupler input system ; input resistance : 560 Ω ; +12V, +24V terminal input resistance : 670 Ω ; input by DC10.8 ~ 26.4V Input signals for start/stop, brake, direction of rotation selection, electromagnetic brake release, speed selection | | | | | |
| Output signals | | TTL open collector output (equivalent to 74S06) External operating requirements : DC26.4 or less, 20mA or less Output signals for speed ASG, BSG (400P/R, phase lag of 90° as expressed in electrical degrees) | | | | | |
| Protection functions | | When the following protection functions are activated, the alarm signal is output and the motor stops naturally : <ul style="list-style-type: none"> • Overload : Activated when a load exceeding the rated torque is applied to the motor for 5 seconds or more • Overheat : Activated when the temperature of the driver's internal radiator exceeds 80 °C • Overvoltage : Activated when the primary voltage of the driver's inverter exceeds the permissible value. | | | | | |
| Rated duty cycle | | Continuous | | | | | |
| Mass | Motor (kg) | 1.0 | 1.9 | 2.8 | 4.0 | 3.9 | |
| | Driver (kg) | 1.4 | | | | | |

*1 When using the gearhead, refer to geared motor torque table on page 33.

*2 The duration of use of the peak torque is 5 seconds or less at 2000r/min.

(2) Electromagnetic Brakes models These specifications are applicable when the driver is used in combination with a servo-motor.

| | | | | | | | |
|--|---|------|--|---|---|--|---|
| Unit Model | Round shaft type | 100V | KBL230-A2M | KBL460-A2M | KBL5120-A2M | KBL6180-A2M | - |
| | | 200V | KBL230-CM | KBL460-CM | KBL5120-CM | KBL6180-CM | KBL6400-CM |
| Pinion shaft type | 100V | | KBL230GD-A2M | KBL460GD-A2M | KBL5120GD-A2M | KBL6180GD-A2M | - |
| | 200V | | KBL230GD-CM | KBL460GD-CM | KBL5120GD-CM | KBL6180GD-CM | KBL6400GH-CM |
| Motor's Rated Output | [W] | | 30 | 60 | 120 | 180 | 400 |
| Rated Speed | [r/min] | | 3000 | | | | |
| Rated Torque*1 | [N · m] ([kgcm]) | | 0.1 (1.0) | 0.2 (2.0) | 0.4 (4.0) | 0.6 (6.0) | 1.3 (13.0) |
| Peak Torque*2 | [N · m] ([kgcm]) | | 0.2 (2.0) | 0.4 (4.0) | 0.8 (8.0) | 1.2 (12.0) | 2.6 (26.0) |
| Speed Control Range | [r/min] | | 30 ~ 3000 | | | | |
| Acceleration/Deceleration | | | 0.5 sec ~ 15 sec (3000r/min) | | | | |
| | Relative to load | | - 0.1% (3000r/minat rated torque) | | | | |
| Speed fluctuation ratio | Relative to voltage | | ± 0.1% (single-phase 100V /115V + 10% ~ - 15%、single-phase 200V/230V + 10% ~ - 15%、3000r/min, with no load applied) | | | | |
| | Relative to temperature | | ± 0.5% (0 ~ + 40、3000 r/min, with no load applied) | | | | |
| Rotor Inertial Moment | J [kgm ²] (GD ² [kgcm ²]) | | 1.2 × 10 ⁻⁵ (0.5) | 5.87 × 10 ⁻⁵ (2.35) | 1.2 × 10 ⁻⁴ (4.8) | 1.8 × 10 ⁻⁴ (7.3) | 1.23 × 10 ⁻⁴ (4.9) |
| Suitable Load Inertial Moment | J [kgm ²] (GD ² [kgcm ²]) | | 5.7 × 10 ⁻⁵ or less (2.3 or less) | 2.87 × 10 ⁻⁴ or less (11.5 or less) | 5.62 × 10 ⁻⁴ or less (22.5 or less) | 8.7 × 10 ⁻⁴ or less (35 or less) | 17.5 × 10 ⁻⁴ or less (70 or less) |
| Electromagnetic brake*3 static friction torque | [N · m] ([kgcm]) | | 0.1 (1.0) | 0.2 (2.0) | 0.4 (4.0) | 0.6 (6.0) | 1.3 (13.0) |
| Power supply Input | Voltage and Frequency | 100V | single-phase 100/115V + 10% ~ - 15% 50/60Hz | | | | |
| | | 200V | single-phase 200/230V + 10% ~ - 15% 50/60Hz | | | | |
| Maximum Input Current | 100V | | 3.4A | 4.8A | 7.5A | 10.5A | - |
| | 200V | | 2.5A | 3.1A | 4.3A | 5.8A | 11A |
| Motor's Insulation Class | | | Class E (120) | | | | |
| Control System | | | FET Rectangular wave PWM control | | | | |
| Speed Detection System | | | Optical Encoder (400P/R) | | | | |
| Speed Control Command | | | By one of the following : • Internal speed potentiometers (3) • External speed potentiometer (20k , 1/4W) • DC voltage control (DC0 ~ 5V) | | | | |
| Input signals | | | Photocoupler input system ; input resistance : 560 ; +12V, +24V terminal input resistance : 670 ; input by DC10.8 ~ 26.4V Input signals for start/stop, brake, direction of rotation selection, electromagnetic brake release, speed selection | | | | |
| Out put signals | | | TTL open collector output (equivalent to 74S06) External operating requirements : DC26.4 or less, 20mA or less Output signals for speed ASG, BSG (400P/R, phase lag of 90° as expressed in electrical degrees) | | | | |
| Protection functions | | | When the following protection functions are activated, the alarm signal is output and the motor stops naturally : • Overload : Activated when a load exceeding the rated torque is applied to the motor for 5 seconds or more • Overheat : Activated when the temperature of the driver's internal radiator exceeds 80 . • Overvoltage : Activated when the primary voltage of the driver's inverter exceeds the permissible value. | | | | |
| Rated duty cycle | | | Continuous | | | | |
| Mass | Motor (kg) | | 1.4 | 2.3 | 3.5 | 4.8 | 4.9 |
| | Driver (kg) | | 1.4 | | | | |

*1 When using the gearhead, refer to geared motor torque table on page 33.

*2 The duration of use of the peak torque is 5 seconds or less at 2000r/min.

*3 The electromagnetic brake is used to hold position and to make emergency stops when power is off ; it cannot be used for frequent braking

8.2 General Specifications

(1) Standard models

| Equipment Component | | Servo Motor (Except encoder) | Servo Driver |
|-----------------------|---------------------|---|---|
| Insulation Resistance | | 100M or more when 500V DC is applied between the windings and the frame. | 100M or more when 500V DC is applied between the power supply terminal and the frame. |
| Dielectric Strength | | Sufficient to withstand 1.5 kV at 50Hz applied between the winding and the frame. | Sufficient to withstand 1kV (1.5kV for 200V model) at 50Hz applied between the power supply terminal and the frame. |
| Operating Environment | Ambient Temperature | 0 ~ +40 (no freezing) | |
| | Humidity | 85% or less no condensation) | |
| | Atmosphere | No corrosive gases or dust | |

(2) Electromagnetic Brake models

| Equipment Component | | Servo Motor (Except encoder) | Servo Driver |
|-----------------------|---------------------|---|---|
| Insulation Resistance | | 100M or more when 500V DC is applied between the windings and the frame. | 100M or more when 500V DC is applied between the power supply terminal and the frame. |
| Dielectric Strength | | Sufficient to withstand 1.5 kV at 50Hz applied between the winding and the frame. (1kV at 50Hz applied between the electromagnetic brake and the frame. | Sufficient to withstand 1kV (1.5kV for 200V model) at 50Hz applied between the power supply terminal and the frame. |
| Operating Environment | Ambient Temperature | 0 ~ +40 (no freezing) | |
| | Humidity | 85% or less (no condensation) | |
| | Atmosphere | No corrosive gases or dust | |

Note

Never attempt to perform an insulation resistance test or dielectric strength test with the motor and driver connected, since this can result in damage.

Also, do not perform these tests on the motor's encoder.

8.3 Geared motor Torque Table

[N • m] ([kgcm])

| Gear ratio | | 5 | 10 | 15 | 20 | 30 | 50 | 100 | 200 |
|----------------------|---------------------------|-----------|-----------|-----------|-----------|-----------|-----------|-----------|-----------|
| Speed range (r/min) | | 6 ~ 600 | 3 ~ 300 | 2 ~ 200 | 1.5 ~ 150 | 1 ~ 100 | 0.6 ~ 60 | 0.3 ~ 30 | 0.15 ~ 15 |
| Motor/gearhead model | | 6 ~ 600 | 3 ~ 300 | 2 ~ 200 | 1.5 ~ 150 | 1 ~ 100 | 0.6 ~ 60 | 0.3 ~ 30 | 0.15 ~ 15 |
| KBL230GD- /2GD K | Permissible thrust load | 0.4 (4) | 0.81(8.1) | 1.2(12) | 1.6(16) | 2.1(21) | 3.0(30) | 4.0(40) | 4.0(40) |
| | Permissible overhung load | 81% | | | 73% | | | 66% | |
| KBL460GD- /4GD K | Permissible thrust load | 0.81(8.1) | 1.6(16) | 2.4(24) | 2.9(29) | 4.3(43) | 7.2(72) | 10.0(100) | 10.0(100) |
| | Permissible overhung load | 81% | | | 73% | | | 66% | |
| KBL5120GD- /5GD K | Permissible thrust load | 1.6(16) | 3.2(32) | 4.8(48) | 5.8(58) | 8.7(87) | 14.5(145) | 20.0(200) | 20.0(200) |
| | Permissible overhung load | 81% | | | 73% | | | 66% | |
| KBL5120GD- /5GD RA | Permissible thrust load | 1.2(12) | 2.4(24) | 3.6(36) | 4.8(48) | 7.2(72) | 10.8(108) | 20.0(200) | 20.0(200) |
| | Permissible overhung load | 60% | | | | | 54% | | 45% |
| KBL6180GD- /6GD K | Permissible thrust load | 2.4(24) | 4.8(48) | 7.3(73) | 8.7(87) | 13.1(131) | 21.8(218) | 30.0(300) | 30.0(300) |
| | Permissible overhung load | 81% | | | 73% | | | 66% | |
| KBL6400GH- /6GH K | Permissible thrust load | 5.2(52) | 10.5(105) | 15.7(157) | 18.9(189) | 28.4(284) | 40.0(400) | 40.0(400) | 40.0(400) |
| | Permissible overhung load | 81% | | | 73% | | | 66% | |

- The box represents the desired gear ratio, which thereby becomes part of the code for the gearhead. (Gear ratios given in the table are the standard specifications) .
- Gray portions of the table give the values that apply when the gearhead and motor rotate in the same direction ; the uncolored (white) portions give the values that apply when they rotate in opposite directions.
- The percentages given in the table represent the gearhead's efficiency.
- Gearheads use ball bearings in all stages.

8.4 Permissible thrust load and permissible overhung load of gearhead output shaft

[N] ([kg])

| Gearhead model | | Gear ratio | | 5 | 10 | 15 | 20 | 30 | 50 | 100 | 200 |
|----------------|---------------------------|--------------------------------|---------|---|---------|----|-----------|----|---------|-----|-----|
| 2GD K | Permissible thrust load | | 50(5) | | | | | | | | |
| | Permissible overhung load | 10mm from the end of the shaft | 100(10) | | | | | | 150(15) | | |
| | | 20mm from the end of the shaft | 150(15) | | | | | | 250(25) | | |
| 4GD K | Permissible thrust load | | 100(10) | | | | | | | | |
| | Permissible overhung load | 10mm from the end of the shaft | 250(25) | | | | 300(30) | | | | |
| | | 20mm from the end of the shaft | 350(35) | | | | 450(45) | | | | |
| 5GD K | Permissible thrust load | | 150(15) | | | | | | | | |
| | Permissible overhung load | 10mm from the end of the shaft | 300(30) | | | | 400(40) | | | | |
| | | 20mm from the end of the shaft | 500(50) | | | | 600(60) | | | | |
| 5GD RA | Permissible thrust load | | 250(25) | | | | | | | | |
| | Permissible overhung load | 10mm from the end of the shaft | 400(40) | | 450(45) | | 500(50) | | | | |
| | | 20mm from the end of the shaft | 500(50) | | 600(60) | | 700(70) | | | | |
| 6GD K | Permissible thrust load | | 150(15) | | | | | | | | |
| | Permissible overhung load | 10mm from the end of the shaft | 300(30) | | | | 400(40) | | | | |
| | | 20mm from the end of the shaft | 500(50) | | | | 600(60) | | | | |
| 6GH K | Permissible thrust load | | 200(20) | | | | | | | | |
| | Permissible overhung load | 10mm from the end of the shaft | 550(55) | | | | 650(65) | | | | |
| | | 20mm from the end of the shaft | 800(80) | | | | 1000(100) | | | | |

8.5 Lowering Operation Capacity

30W ~ 180W type in the KBLII series are capable of continuous lowering operation up to an output of 30W.

Lowering operation above 30W cannot be performed for continuous periods since overload protection is not activated

when the motor is operated below the rated torque. Therefore, when performing lowering operations above 30W, pay attention to the driver temperature rises and use a operating cycle that will not cause overheating protection to activate.

When unwinding on the KBL6400 model, always use the regeneration unit option (RGK100) .

When the regeneration unit is used, continuous lowering operation capacity is 100W.

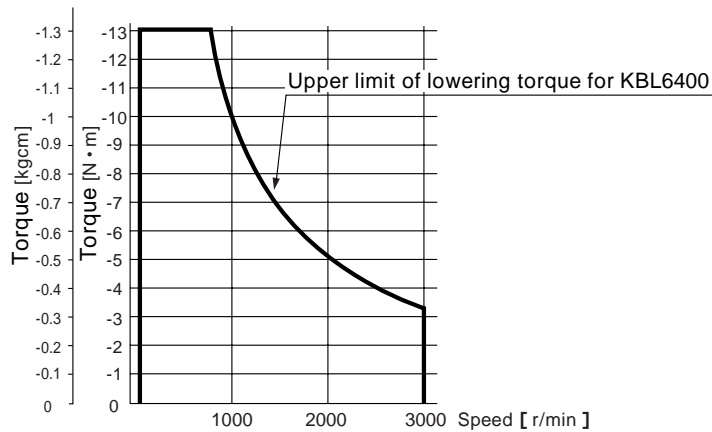
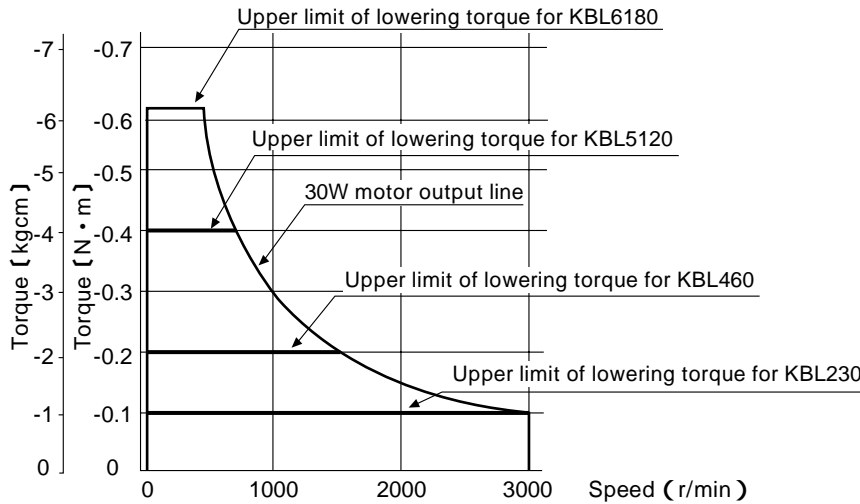

8.6 Speed-Torque Characteristics

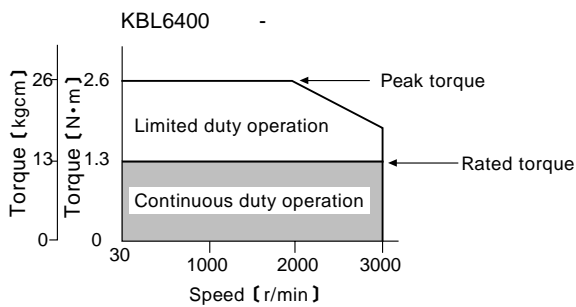
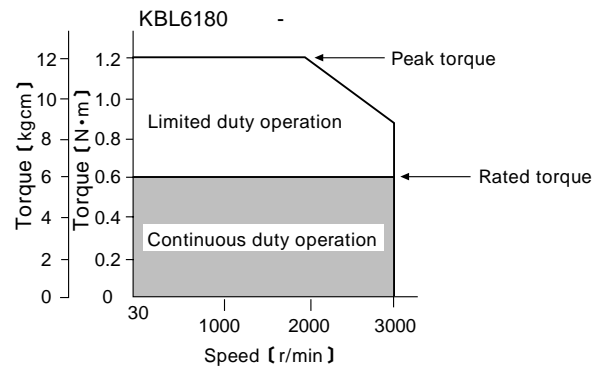
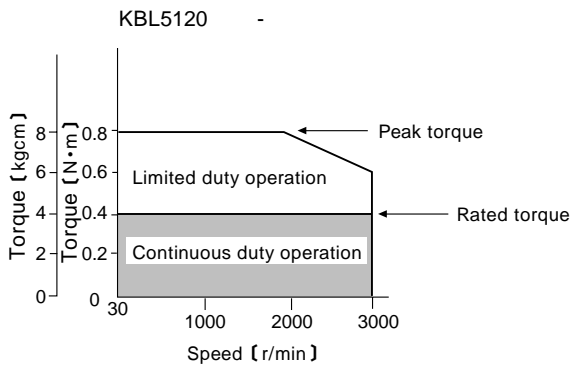
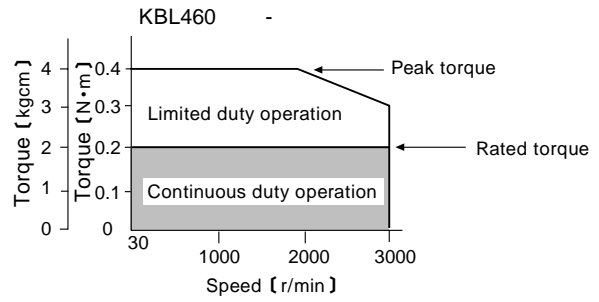
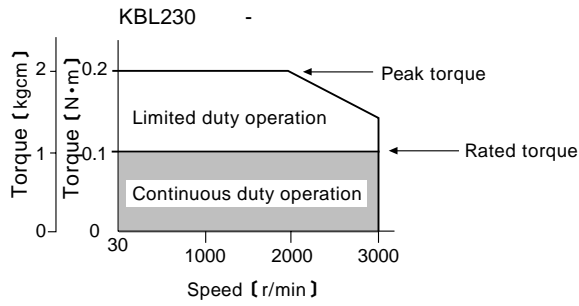

Limited duty operation :
Primarily speed adjustment operation.
The duration of use of the peak torque is
5 seconds or less at 2000 r/min.

* When using the gearhead, refer to Gearmotor Torque Table on page 33.

8.7 Load Torque - Driver Input Current Characteristics

In KBLII series motors, the driver's input current varies with the load torque. Since the load torque and driver input current are nearly proportional, these characteristics can be used to estimate the load torque from the driver input current (so long as the motor is operated at constant speed) . These characteristics are not applicable when starting the motor or when reversing the direction of rotation because larger currents are used at these times.

(1) 100V input

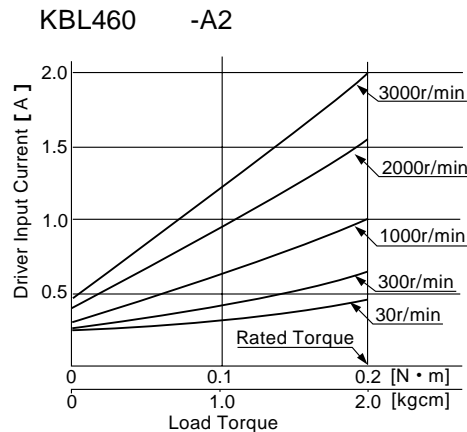
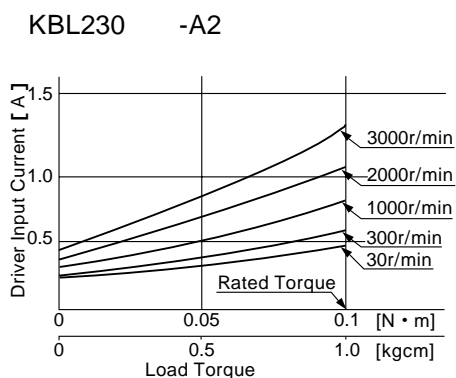

KBL5120 -A2

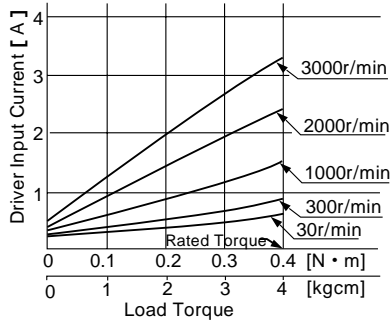

KBL6180 -A2

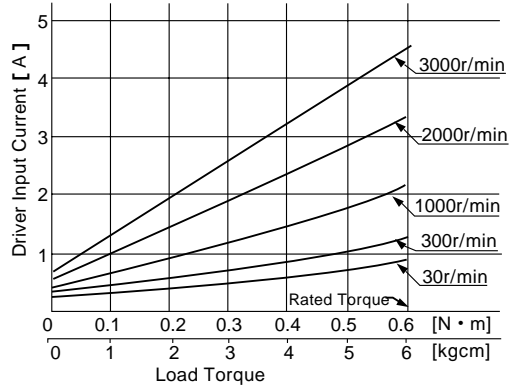

(2) 200V input

KBL230 -C

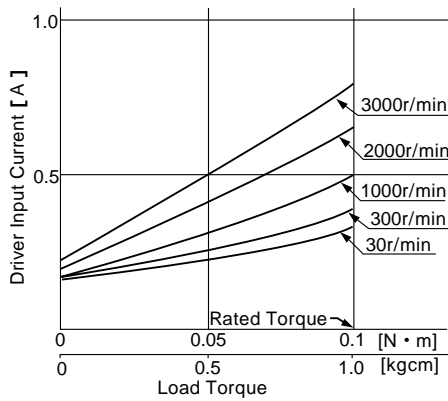

KBL460 -C

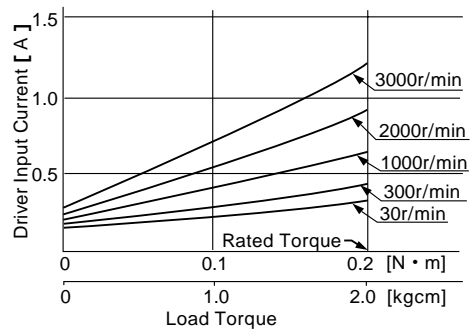

KBL5120 -C

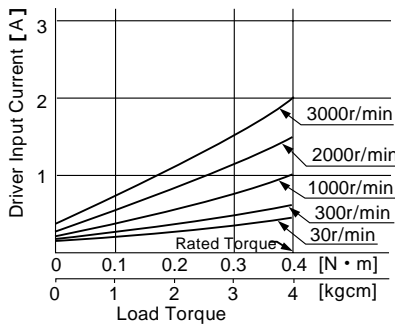

KBL6180 -C

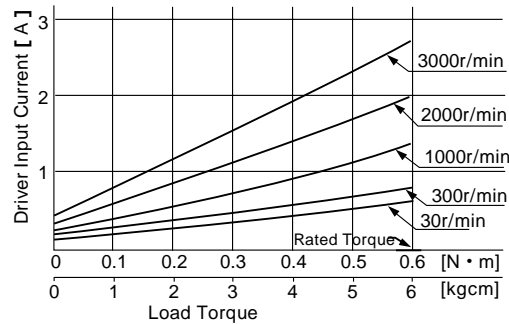

KBL6400 -C

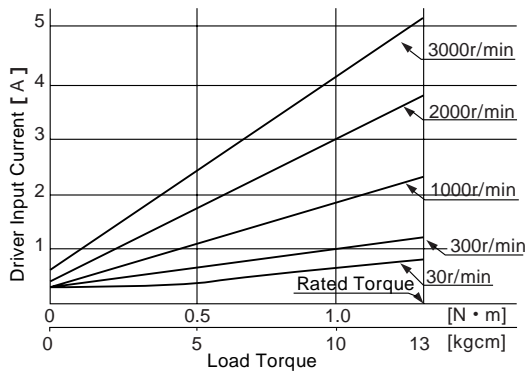

9. Dimensions

(Scale 1/4, Unit= mm)

9.1 Servo Motor

9.1.1 Standard type

(1) Round shaft type

KBLM230-A

KBLM230-C

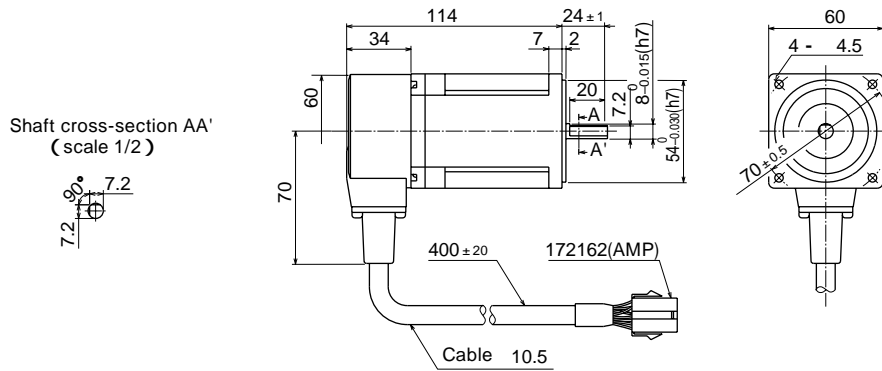

KBLM460-A

KBLM460-C

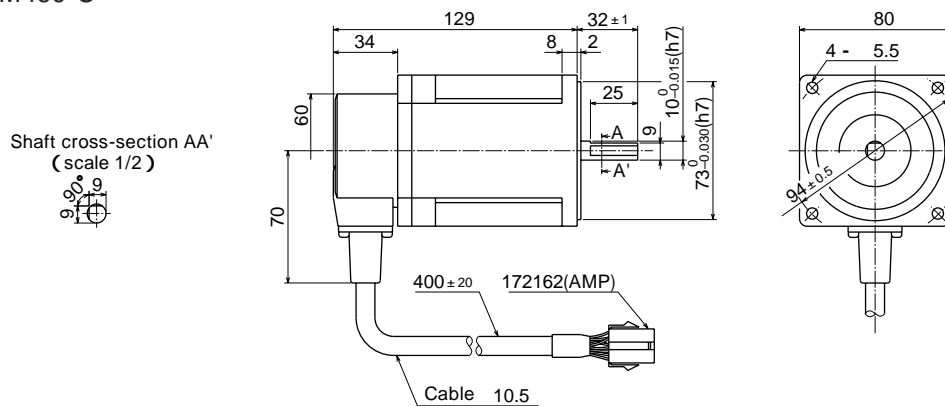

KBLM5120-A

KBLM5120-C

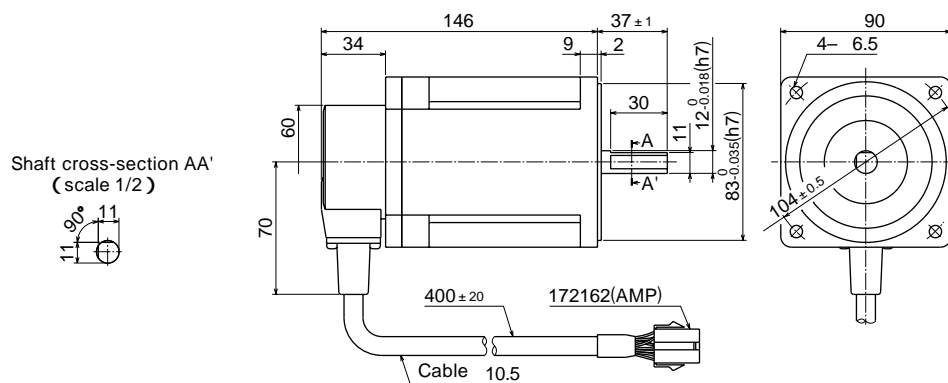

KBLM6180-A
KBLM6180-C

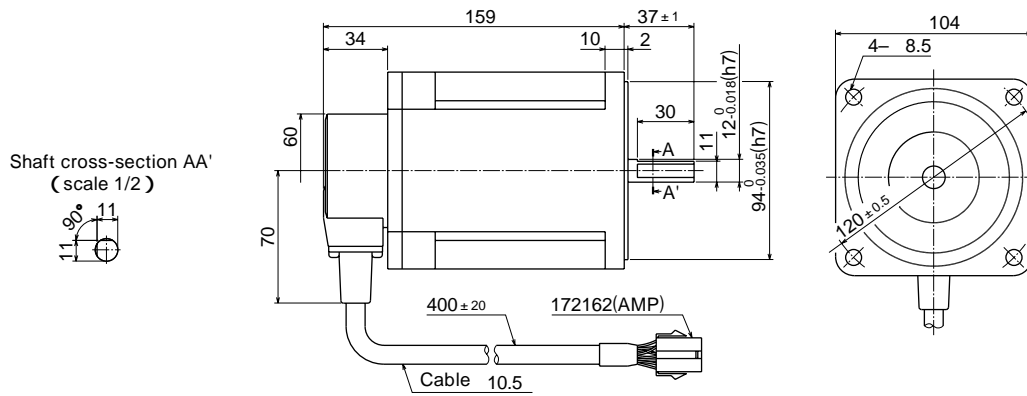

KBLM6400-C

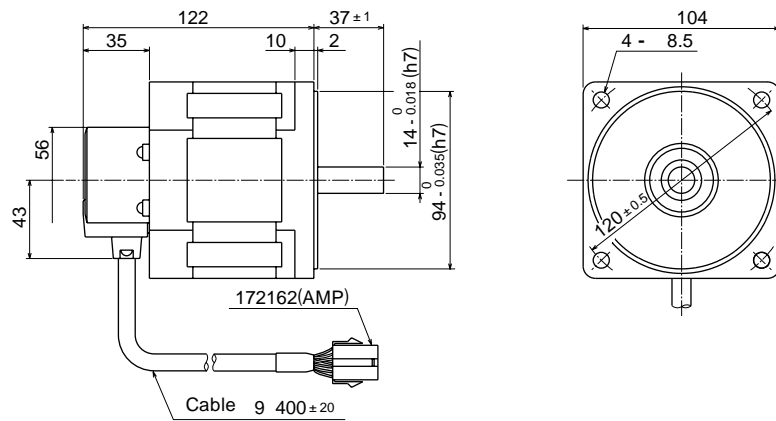

(2) Pinion Shaft type (with GD-type gearheads)

Gearheads are sold separately.

KBLM230GD-A

KBLM230GD-C

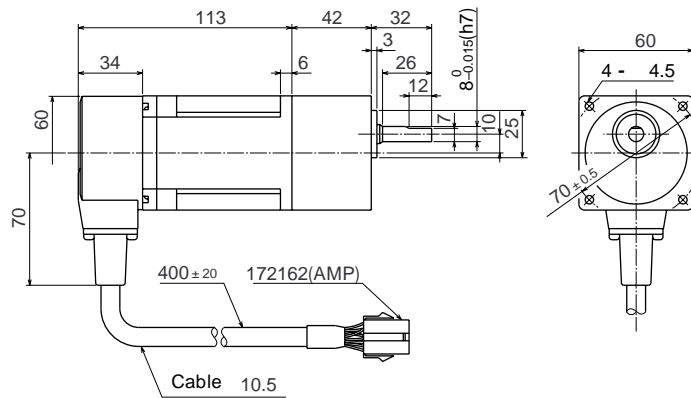

KBLM460GD-A

KBLM460GD-C

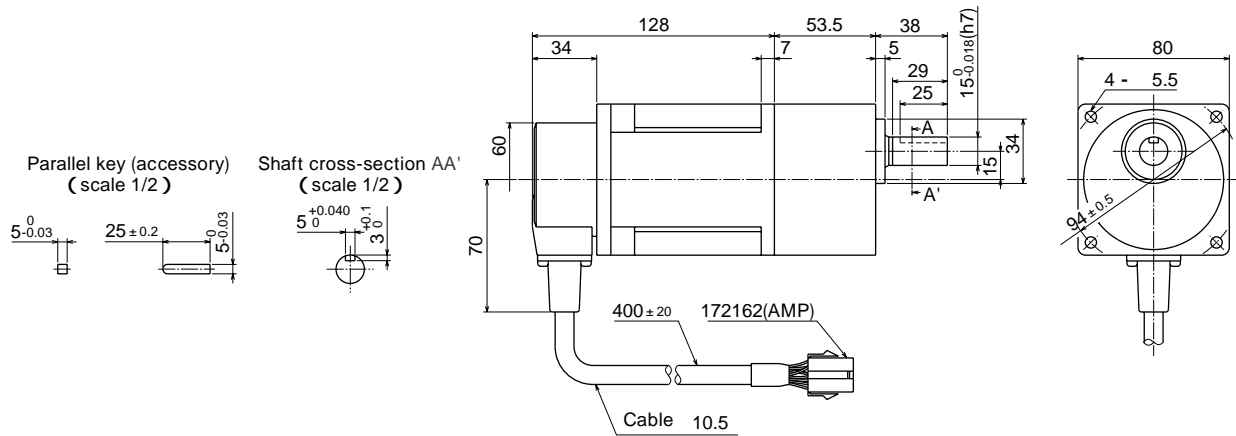

KBLM5120GD-A

KBLM5120GD-C

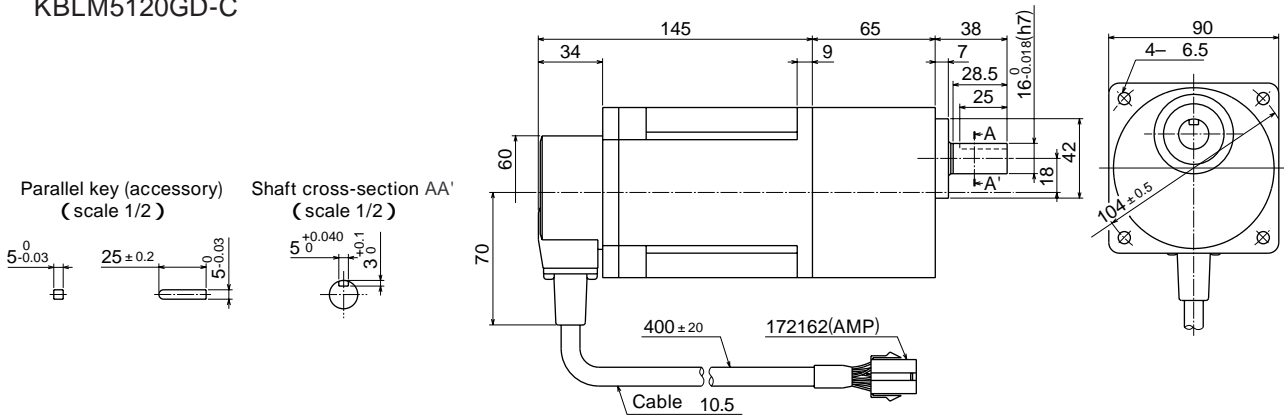

KBLM6180GD-A
KBLM6180GD-C

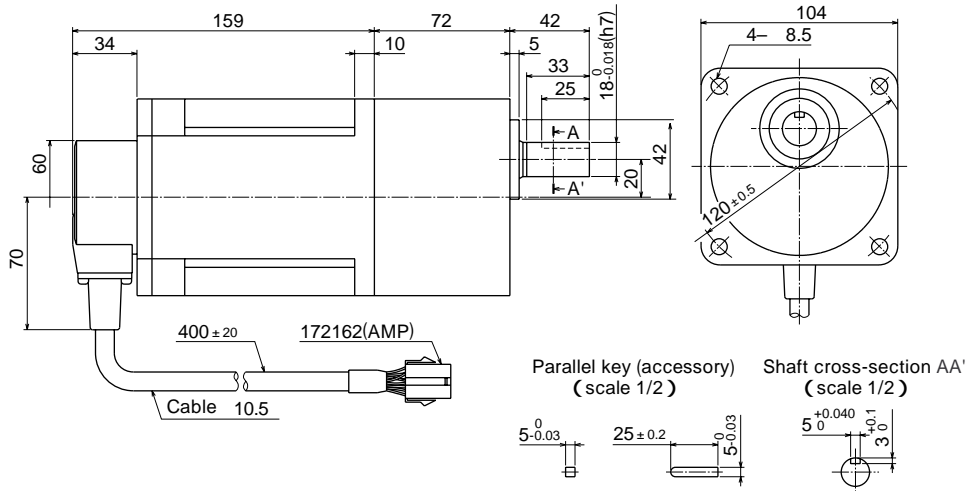

(with GH-type gearheads) Gearheads are sold separately.

KBLM6400GH-C

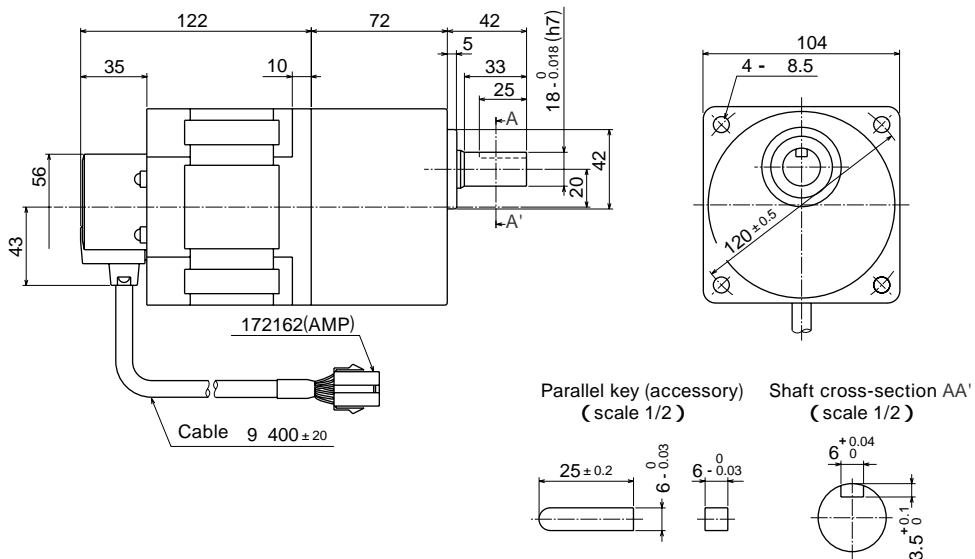

(with RA-type gearheads) Gearheads are sold separately.

KBLM5120GD-A / 5GD RA

KBLM5120GD-C / 5GD RA

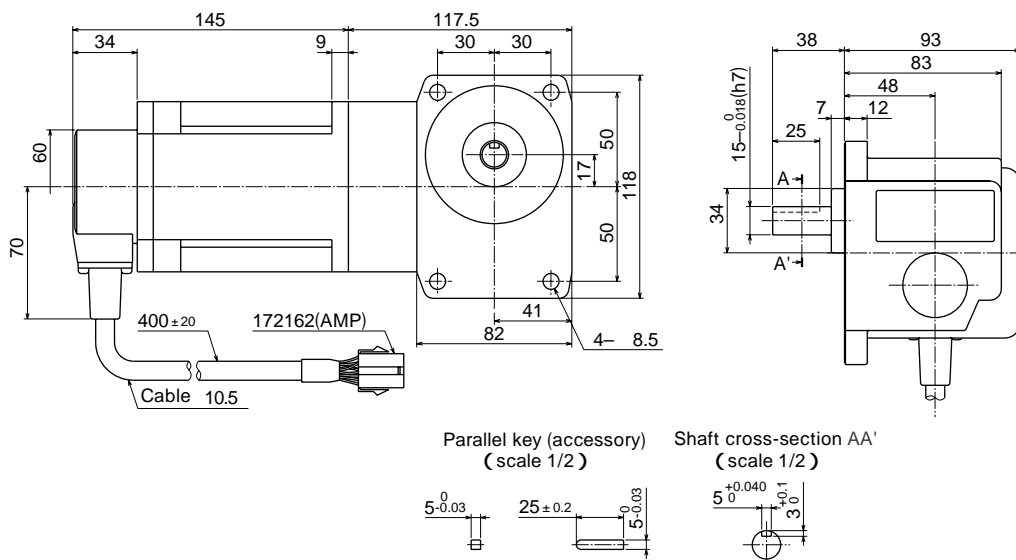

9.1.2 Electromagnetic Brake Type

(1) Round shaft type

KBLM230-AM

KBLM230-CM

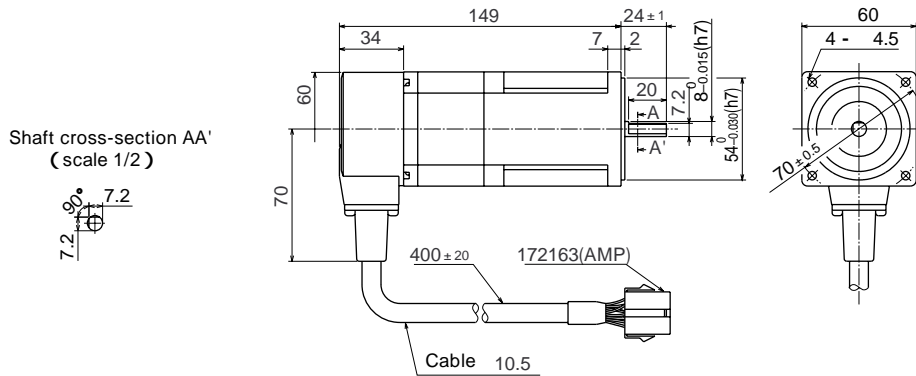

KBLM460-AM

KBLM460-CM

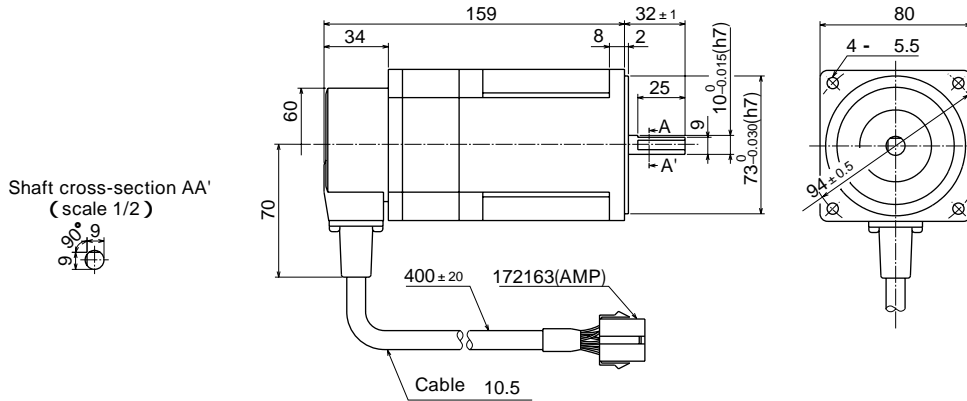

KBLM5120-AM

KBLM5120-CM

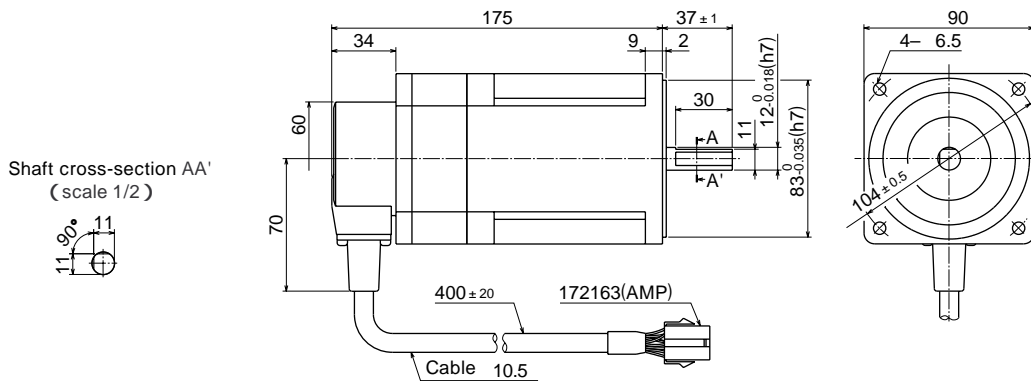

KBLM6180-AM
KBLM6180-CM

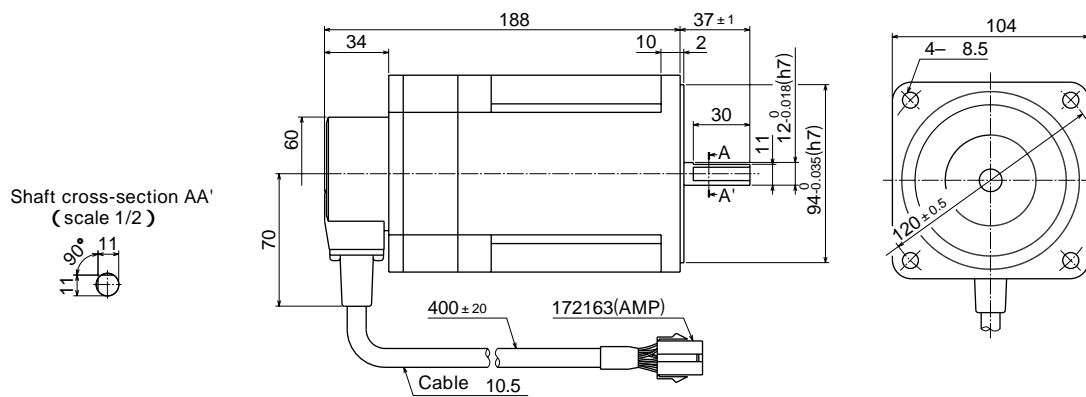

KBLM6400-CM

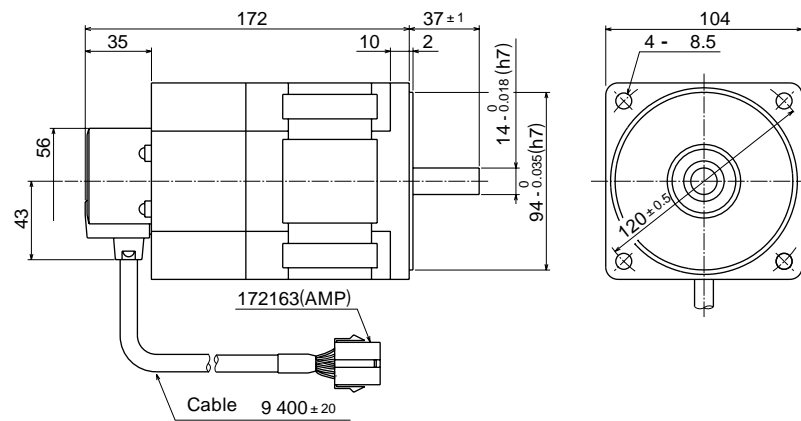

(2) Pinion Shaft type (with GD-type gearheads)

Gearheads are sold separately

KBLM230GD-AM

KBLM230GD-CM

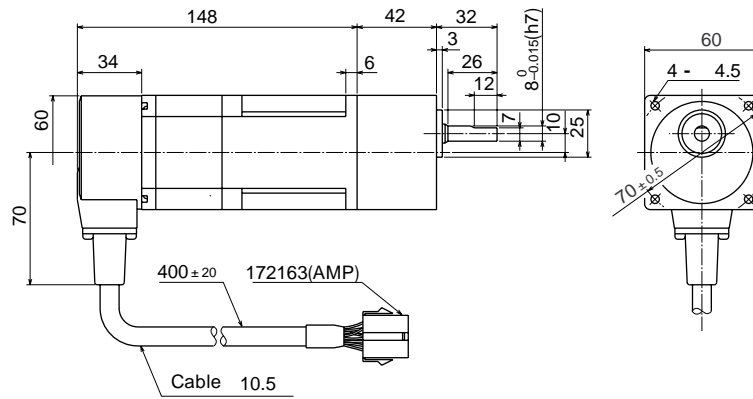

KBLM460GD-AM

KBLM460GD-CM

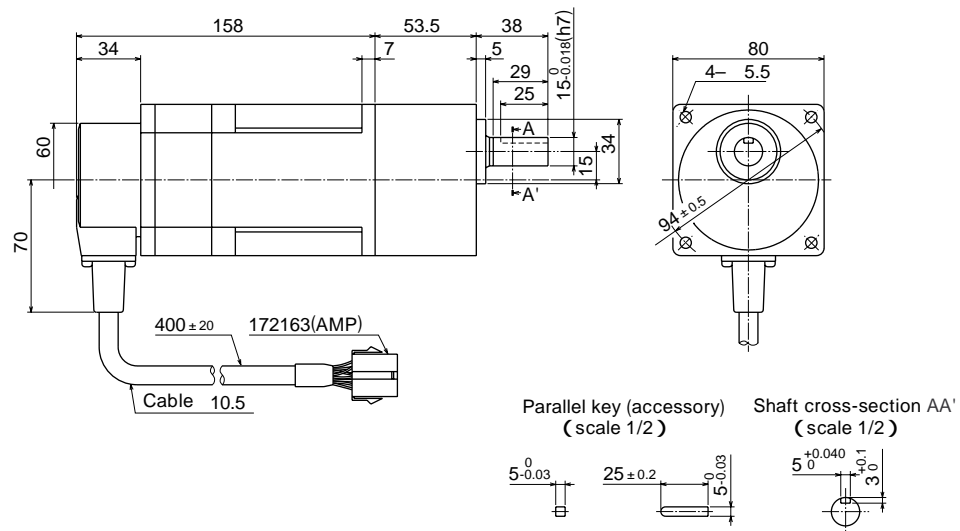

KBLM5120GD-AM

KBLM5120GD-CM

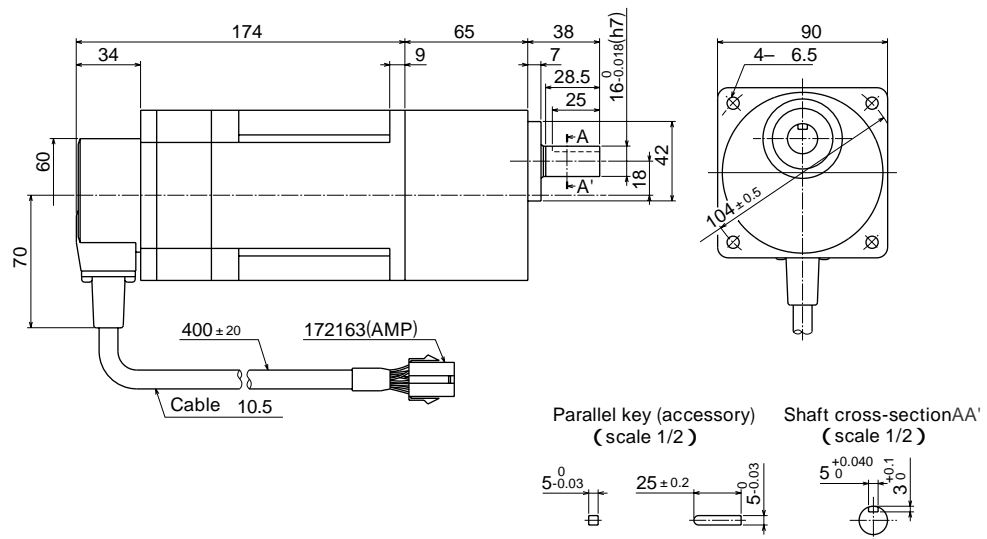

KBLM6180GD-AM
KBLM6180GD-CM

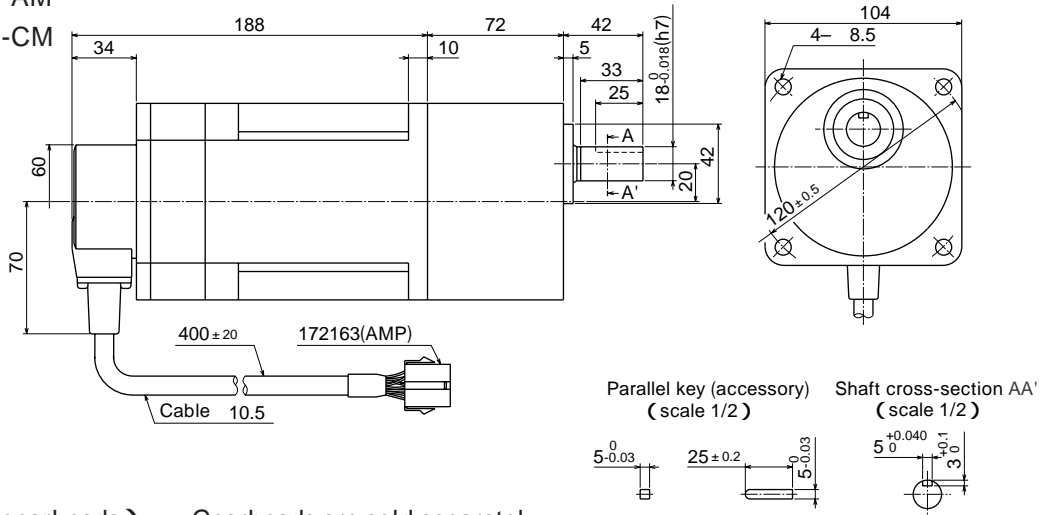

(with GH-type gearheads) Gearheads are sold separately.

KBLM6400GH-CM

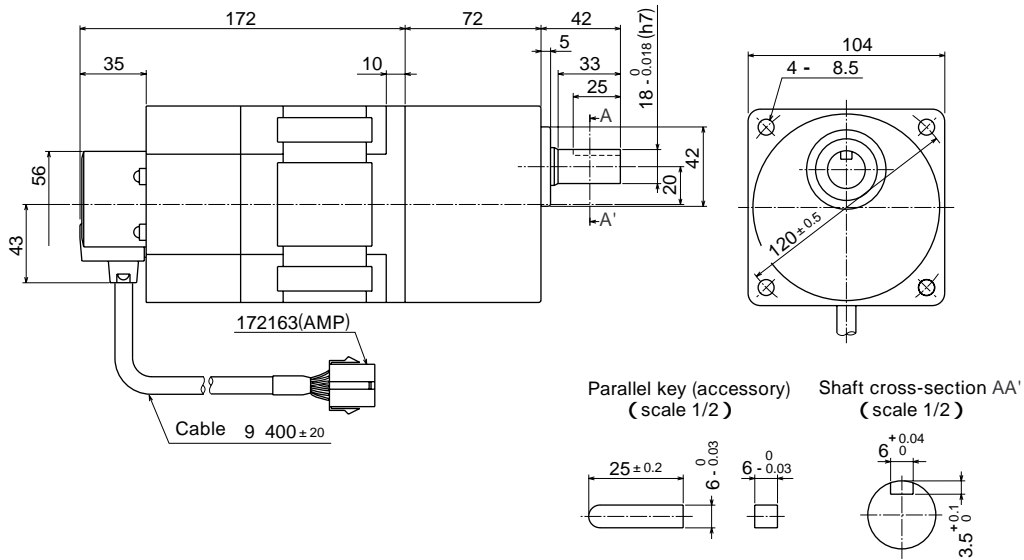

(with RA-type gearheads) Gearheads are sold separately.

KBLM5120GD-AM / 5GD RA
KBLM5120GD-CM / 5GD RA

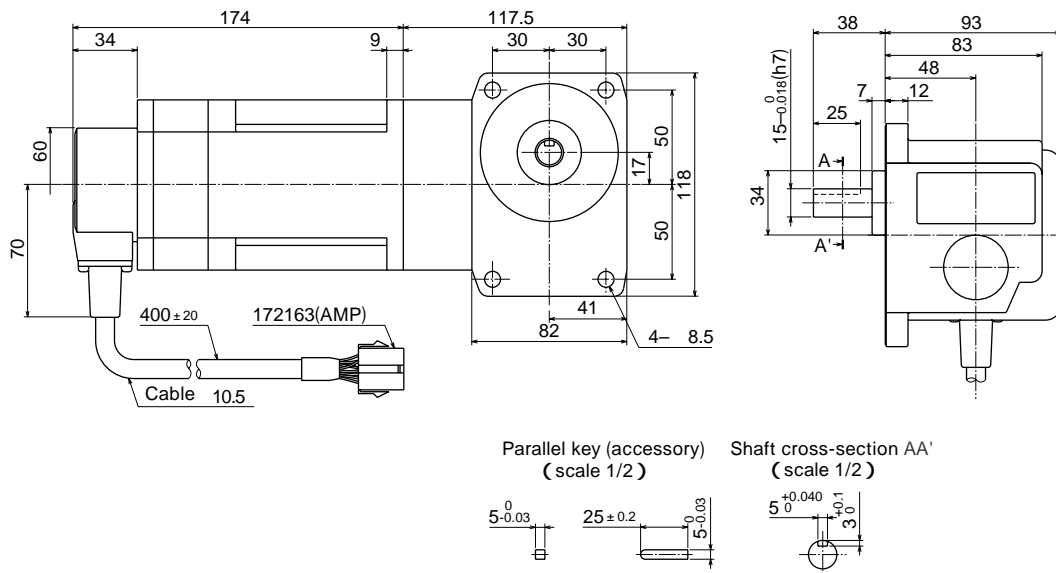

9.2 Servo Driver

KBLD30-A, KBLD60-A,
KBLD120-A, KBLD180-A
KBLD30-C, KBLD60-C,
KBLD120-C, KBLD180-C

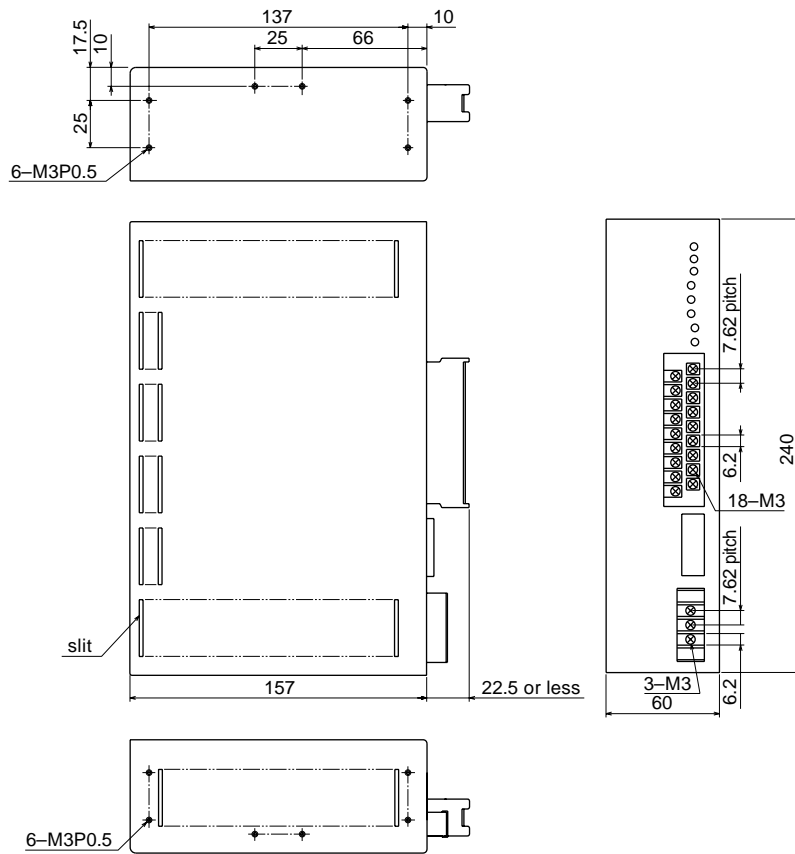

KBLD400-C , KBLD400-CM

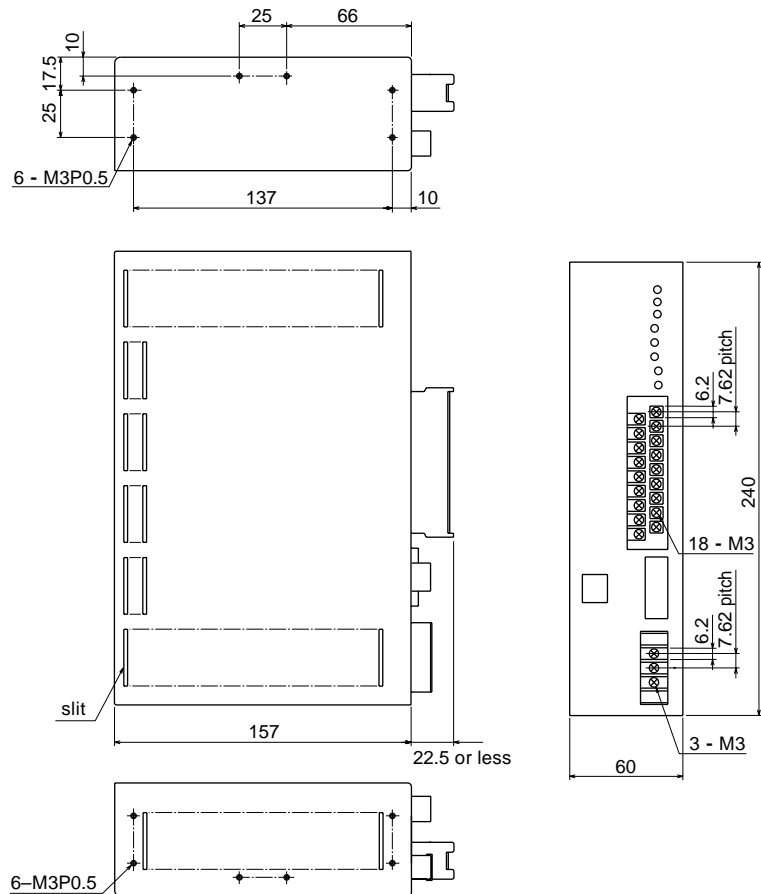

9.3 Accessories

(1) External speed potentiometer (variable resistor)

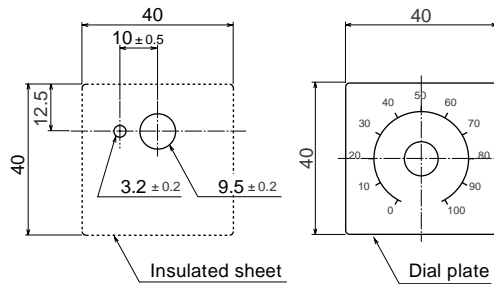
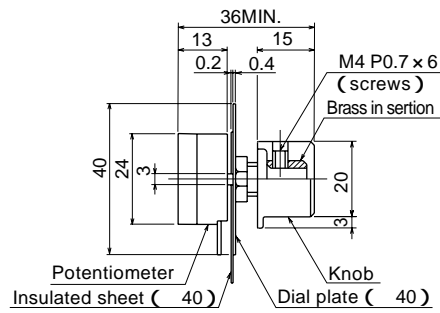

(2) Driver mounting brackets (2-pieces set included with driver)

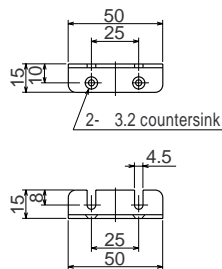

(3) Junction cable

• Junction cable (for standard type)

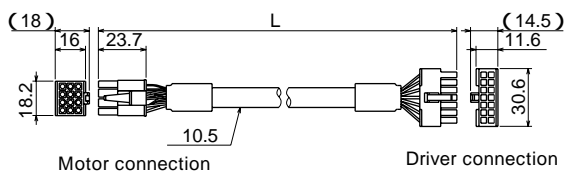

• Junction cable (for electromagnetic type)

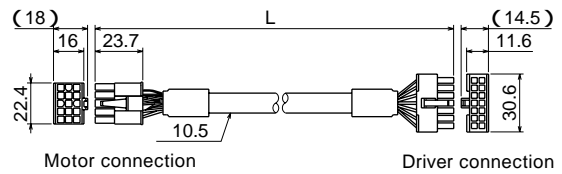

Cable included Models are provided with 1.6m of junction cable.

Eight varieties of junction cables are available. The cable may be purchased in 1m, 1.6m, 3m, 5m, 7m, 10m, 15m and 20m lengths.

ORIENTAL MOTOR.

- Characteristics, specifications and dimensions are subject to change without notice.
- Please contact your nearest ORIENTAL MOTOR office for further information.

ORIENTAL MOTOR U.S.A. CORP.

Los Angeles Office
Tel:(310)784-8200 Fax:(310)325-1076
San Jose Office
Tel:(408)358-6900 Fax:(408)358-8200
Chicago Office
Tel:(847)240-2649 Fax:(847)240-2753
Cincinnati Office
Tel:(513)563-2722 Fax:(513)956-3183
Austin Office
Tel:(512)918-9438 Fax:(512)335-5983
New York Office
Tel:(973)359-1100 Fax:(973)359-1090
Boston Office
Tel:(781)848-2426 Fax:(781)848-2617
Atlanta Office
Tel:(770)716-2800 Fax:(770)719-8515
Canada Office
Tel:(905)502-5333 Fax:(905)502-5444

ORIENTAL MOTOR (EUROPA) GmbH

Headquarters and Düsseldorf Office
Tel:02131-95280 Fax:02131-952899
Munich Office
Tel:08131-59880 Fax:08131-598888
Hamburg Office
Tel:04076-910443 Fax:04076-910445

ORIENTAL MOTOR (UK) LTD.

Tel:01252-519809 Fax:01252-547086

ORIENTAL MOTOR (FRANCE) SARL

Tel:01 47 86 97 50 Fax:01 47 82 45 16

ORIENTAL MOTOR ITALIA s.r.l.

Tel:02-3390541 Fax:02-33910033

TAIWAN ORIENTAL MOTOR CO., LTD.

Tel:(02)2299-9360 Fax:(02)2299-4173

SINGAPORE ORIENTAL MOTOR PTE LTD.

Tel:(745)7344 Fax:(745)9405

ORIENTAL MOTOR• KOREA CO., LTD.

Tel:(02)632-9122 Fax:(02)679-4588

ORIENTAL MOTOR CO., LTD.

Headquarters
Tel:(03)3835-0684 Fax:(03)3835-1890

Technical Support Line Tel:(800)468-3982
Available from 8:30 AM to 8:00 PM. Eastern Time



Artisan Scientific

QUALITY INSTRUMENTATION ... GUARANTEED

Looking for more information?

Visit us on the web at <http://www.artisan-scientific.com> for more information:

- Price Quotations
- Drivers
- Technical Specifications, Manuals and Documentation

Artisan Scientific is Your Source for Quality New and Certified-Used/Pre-owned Equipment

- Tens of Thousands of In-Stock Items
- Hundreds of Manufacturers Supported
- Fast Shipping and Delivery
- Leasing / Monthly Rentals
- Equipment Demos
- Consignment

Service Center Repairs

Experienced Engineers and Technicians on staff in our State-of-the-art Full-Service In-House Service Center Facility

InstraView™ Remote Inspection

Remotely inspect equipment before purchasing with our Innovative InstraView™ website at <http://www.instraview.com>

We buy used equipment! We also offer credit for Buy-Backs and Trade-Ins

Sell your excess, underutilized, and idle used equipment. Contact one of our Customer Service Representatives today!

Talk to a live person: 888-88-SOURCE (888-887-6872) | Contact us by email: sales@artisan-scientific.com | Visit our website: <http://www.artisan-scientific.com>