



## Artisan Technology Group is your source for quality new and certified-used/pre-owned equipment

- FAST SHIPPING AND DELIVERY
- TENS OF THOUSANDS OF IN-STOCK ITEMS
- EQUIPMENT DEMOS
- HUNDREDS OF MANUFACTURERS SUPPORTED
- LEASING/MONTHLY RENTALS
- ITAR CERTIFIED SECURE ASSET SOLUTIONS

### SERVICE CENTER REPAIRS

Experienced engineers and technicians on staff at our full-service, in-house repair center

### *InstraView*<sup>SM</sup> REMOTE INSPECTION

Remotely inspect equipment before purchasing with our interactive website at [www.instraview.com](http://www.instraview.com) ↗

### WE BUY USED EQUIPMENT

Sell your excess, underutilized, and idle used equipment. We also offer credit for buy-backs and trade-ins. [www.artisanng.com/WeBuyEquipment](http://www.artisanng.com/WeBuyEquipment) ↗

### LOOKING FOR MORE INFORMATION?

Visit us on the web at [www.artisanng.com](http://www.artisanng.com) ↗ for more information on price quotations, drivers, technical specifications, manuals, and documentation

**Contact us:** (888) 88-SOURCE | [sales@artisanng.com](mailto:sales@artisanng.com) | [www.artisanng.com](http://www.artisanng.com)

# **GPIB-100A**

## **User Manual**

**March 1990 Edition**

**Part Number 320063-01**

**© Copyright 1985, 1991 National Instruments Corporation.  
All Rights Reserved.**

**National Instruments Corporation**  
**6504 Bridge Point Parkway**  
**Austin, TX 78730-5039**

**(512) 794-0100**  
**(800) IEEE-488 (toll-free U.S. and Canada)**  
**Technical support fax: (512) 794-5678**

## **Limited Warranty**

The GPIB-100A is warranted against defects in materials and workmanship for a period of two years from the date of shipment, as evidenced by receipts or other documentation. National Instruments will, at its option, repair or replace equipment that proves to be defective during the warranty period. This warranty includes parts and labor.

A Return Material Authorization (RMA) number must be obtained from the factory and clearly marked on the outside of the package before any equipment will be accepted for warranty work. National Instruments will pay the shipping costs of returning to the owner parts which are covered by warranty.

National Instruments believes that the information in this manual is accurate. The document has been carefully reviewed for technical accuracy. In the event that technical or typographical errors exist, National Instruments reserves the right to make changes to subsequent editions of this document without prior notice to holders of this edition. The reader should consult National Instruments if errors are suspected. In no event shall National Instruments be liable for any damages arising out of or related to this document or the information contained in it.

EXCEPT AS SPECIFIED HEREIN, NATIONAL INSTRUMENTS MAKES NO WARRANTIES, EXPRESS OR IMPLIED, AND SPECIFICALLY DISCLAIMS ANY WARRANTY OF MERCHANTABILITY OR FITNESS FOR A PARTICULAR PURPOSE. CUSTOMER'S RIGHT TO RECOVER DAMAGES CAUSED BY FAULT OR NEGLIGENCE ON THE PART OF NATIONAL INSTRUMENTS SHALL BE LIMITED TO THE AMOUNT THERETOFORE PAID BY THE CUSTOMER. NATIONAL INSTRUMENTS WILL NOT BE LIABLE FOR DAMAGES RESULTING FROM LOSS OF DATA, PROFITS, USE OF PRODUCTS, OR INCIDENTAL OR CONSEQUENTIAL DAMAGES, EVEN IF ADVISED OF THE POSSIBILITY THEREOF. This limitation of the liability of National Instruments will apply regardless of the form of action, whether in contract or tort, including negligence. Any action against National Instrument must be brought within one year after the cause of action accrues. National Instruments shall not be liable for any delay in performance due to causes beyond its reasonable control. The warranty provided herein does not cover damages, defects, malfunctions, or service failures caused by owner's failure to follow the National Instruments installation, operation, or maintenance instructions; owner's modification of the product; owner's abuse, misuse, or negligent acts; and power failure or surges, fire, flood, accident, actions of third parties, or other events outside reasonable control.

## **Copyright**

Under the copyright laws, this book may not be copied, photocopied, reproduced, or translated, in whole or in part, without the prior written consent of National Instruments Corporation.

## **Trademarks**

Product names listed are trademarks of their respective manufacturers. Company names listed are trademarks or trade names of their respective companies.

# FCC/DOC Radio Frequency Interference Compliance

This equipment generates and uses radio frequency energy and, if not installed and used in strict accordance with the instructions in this manual, may cause interference to radio and television reception. This equipment has been tested and found to comply with (1) the limits for a Class A computing device, in accordance with the specifications in Subpart J of Part 15 of U.S. Federal Communications Commission (FCC) Rules, and (2) the limits for radio noise emissions from digital apparatus set out in the Radio Interference Regulations of the Canadian Department of Communication (DOC). These regulations are designed to provide reasonable protection against interference from the equipment to radio and television reception in commercial areas.

There is no guarantee that interference will not occur in a particular installation. However, the chances of interference are much less if the equipment is used according to this instruction manual.

If the equipment does cause interference to radio or television reception, which can be determined by turning the equipment on and off, one or more of the following suggestions may reduce or eliminate the problem.

- Operate the equipment and the receiver on different branches of your AC electrical system.
- Move the equipment away from the receiver with which it is interfering.
- Relocate the equipment with respect to the receiver.
- Reorient the receiver's antenna.
- Be sure that the equipment is plugged into a grounded outlet and that the grounding has not been defeated with a cheater plug.

If necessary, consult National Instruments or an experienced radio/television technician for additional suggestions. The following booklet prepared by the FCC may also be helpful: *How to Identify and Resolve Radio-TV Interference Problems*. This booklet is available from the U.S. Government Printing Office, Washington, DC 20402, Stock Number 004-000-00345-4.

# Preface

---

## Organization of the Manual

This manual is divided into the following chapters:

Chapter 1, *Description of the GPIB-100A*, contains a brief description of the GPIB-100A Bus Extender and how it is used. This section also lists all components and accessories. In addition, it provides system configuration, performance, operating, electrical, environmental, and physical specifications for the GPIB-100A.

Chapter 2, *Installation*, contains instructions for configuring and connecting the GPIB-100A into your system at your operating voltage.

Chapter 3, *Configuration and Operation*, describes how to configure and operate a GPIB-100A system.

Chapter 4, *Theory of Operation*, contains descriptions of how the GPIB-100A circuitry operates.

Appendix A, *Operation of the GPIB*, describes GPIB terminology and protocol for users unfamiliar with the GPIB.

Appendix B, *Schematic Diagram*, contains a detailed schematic diagram of the GPIB-100A.

Appendix C, *GPIB-100A Parts Locator Diagram*, contains the parts locator diagram for the GPIB-100A.

Appendix D, *Cable Assembly Wire List*, contains the listing of wire connections for the GPIB-100A transmission cable.

Appendix E, *Multiline Interface Messages*, contains an ASCII chart and a list of the corresponding GPIB messages.

Appendix F, *Mnemonics Key*, contains a mnemonics key that defines the mnemonics used throughout the manual.

## Related Document

The following document is a reference that covers in greater detail specific topics introduced in this manual:

- *ANSI/IEEE Standard 488-1978, IEEE Standard Digital Interface for Programmable Instrumentation.*

## Abbreviations Used in the Manual

The following abbreviations are used in the text of this manual.

C	centigrade
F	Fahrenheit
Hz	hertz
in.	inch
kbytes	thousand bytes
m	meter
mA	milliamperes
Mbytes	million bytes
mm	millimeter
$\mu$ sec	microsecond
nsec	nanosecond
sec	second
V	volts
VAC	Volts Alternating Current
W	watt

# Contents

---

## Chapter 1

<b>Description of the GPIB-100A</b> .....	1-1
Introduction.....	1-1
GPIB-100A Specifications .....	1-3

## Chapter 2

<b>Installation</b> .....	2-1
Inspection.....	2-1
Power Connection.....	2-1
Grounding Configuration.....	2-2
Disassembly .....	2-2
Mounting .....	2-2
Connecting to Hewlett-Packard Controllers .....	2-2

## Chapter 3

<b>Configuration and Operation</b> .....	3-1
Operating Modes .....	3-1
Talker/Listener/Controller (TLC) Mode.....	3-1
Talker/Listener (TL) Mode.....	3-2
Setting the Operating Mode .....	3-2
Parallel Poll Response (PPR) Modes.....	3-2
Buffered PPR Mode (Approach 1).....	3-3
Unbuffered PPR Mode (Approach 2).....	3-3
Mixed Mode Operation.....	3-4
Operating the GPIB-100A System.....	3-4

## Chapter 4

<b>Theory of Operation</b> .....	4-1
Diagrams .....	4-1
Power-On .....	4-1
System Controller Detection .....	4-2
Active Controller Detection.....	4-2
Source Handshake Detection .....	4-2
Parallel Polling.....	4-3
Data Direction Control .....	4-4
EOI.....	4-4



**Appendix A**

**Operation of the GPIB**..... A-1

- History of the GPIB..... A-1
- Types of Messages ..... A-1
- Talkers, Listeners, and Controllers..... A-1
- System Controller and Active Controller..... A-2
- GPIB Signals..... A-2
- Data Lines..... A-3
- Handshake Lines..... A-3
  - NRFD (not ready for data)..... A-3
  - NDAC (not data accepted)..... A-4
  - DAV (data valid) ..... A-4
- Interface Management Lines..... A-4
  - ATN (attention)..... A-4
  - IFC (interface clear) ..... A-4
  - REN (remote enable)..... A-4
  - SRQ (service request)..... A-4
  - EOI (end or identify) ..... A-4
- Physical and Electrical Characteristics ..... A-5
- Configuration Restrictions ..... A-7

**Appendix B**

**Schematic Diagram**..... B-1

**Appendix C**

**GPIB-100A Parts Locator Diagram** ..... C-1

**Appendix D**

**Cable Assembly Wire List**..... D-1

**Appendix E**

**Multiline Interface Messages**..... E-1

**Appendix F**

**Mnemonics Key**..... F-1

## Figures

Figure 1-1.	The Model GPIB-100A Bus Extender.....	1-1
Figure 1-2.	Typical GPIB-100A Extension System (Physical Configuration).....	1-2
Figure 1-3.	Typical GPIB-100A Extension System (Logical Configuration).....	1-2
Figure 2-1.	Voltage Selection.....	2-1
Figure 3-1.	Switch Settings for Operating Mode.....	3-2
Figure 3-2.	Switch Settings for Parallel Poll Response Mode.....	3-4
Figure 4-1.	GPIB-100A Block Diagram.....	4-1
Figure A-1.	GPIB Cable Connector.....	A-3
Figure A-2.	Linear Configuration of the GPIB Devices.....	A-5
Figure A-3.	Star Configuration of GPIB Devices.....	A-6
Figure C-1.	GPIB-100A Parts Locator Diagram.....	C-1

## Tables

Table 1-1.	System Configuration Characteristics.....	1-3
Table 1-2.	Performance Characteristics.....	1-4
Table 1-3.	Operating Characteristics.....	1-4
Table 1-4.	Electrical Characteristics.....	1-5
Table 1-5.	Environmental Characteristics.....	1-5
Table 1-6.	Physical Characteristics.....	1-6
Table 1-7.	Components and Accessories.....	1-6
Table D-1.	Cable Assembly Wire List.....	D-1

# Chapter 1

## Description of the GPIB-100A

---

### Introduction

The high-speed GPIB-100A Bus Extender (Figure 1-1) is used in pairs with a special parallel data transmission cable to connect two separate GPIB or IEEE-488 bus systems in a functionally transparent manner.

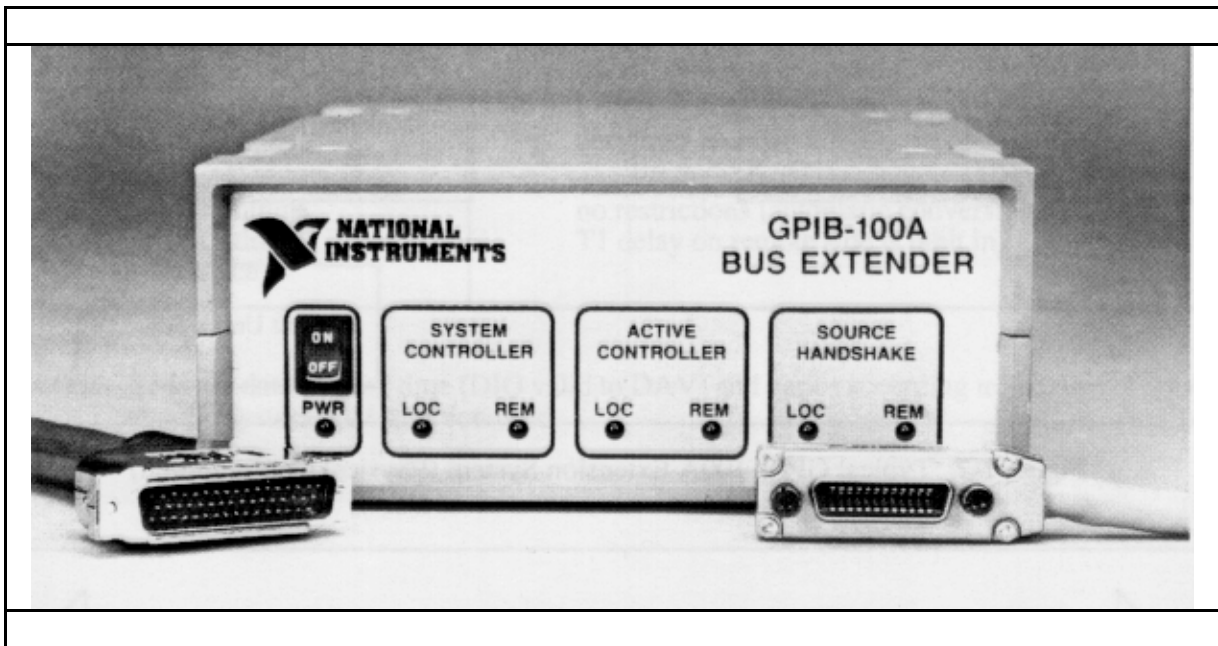

Figure 1-1. The Model GPIB-100A Bus Extender

While the two bus systems are physically separate, as shown in Figure 1-2, devices logically appear to be located on the same bus as shown in Figure 1-3. Thus, with the GPIB-100A it is possible to overcome two configuration restrictions imposed by ANSI/IEEE Standard 488-1978, namely:

- Cable length limit of 20 m total per contiguous bus or 2 m times the number of devices on the bus, whichever is smaller.
- Electrical loading limit of 15 devices per contiguous bus.

Each GPIB-100A system extends the distance limit by 300 m and the loading limit to 30 devices including the extenders, without sacrificing speed or performance. These point-to-point extender systems can be connected in series for longer distances or in star patterns for additional loading.

At short distances, the data transfer rate over the extension can exceed 250 kbytes/sec, degrading with distance only by the propagation delay along the cable. Furthermore, regardless of the distance, there is no speed degradation at all for transfers between devices on the same side of the

extension. And because the GPIB-100A is a functionally transparent extender, the same GPIB communications and control programs that work with an unextended system will work unmodified with an extended system. There is one minor exception to this transparency in conducting parallel polls, as explained in Chapter 3 in the paragraph *Parallel Poll Response (PPR) Modes*.

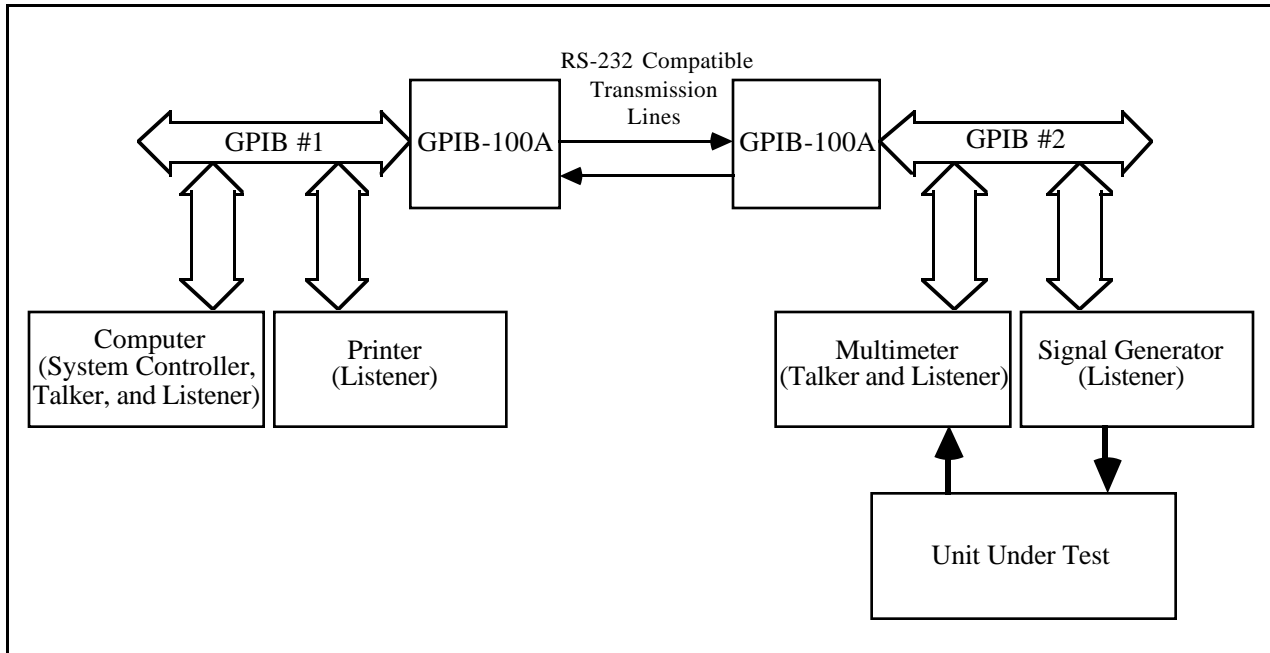

Figure 1-2. Typical GPIB-100A Extension System (Physical Configuration)

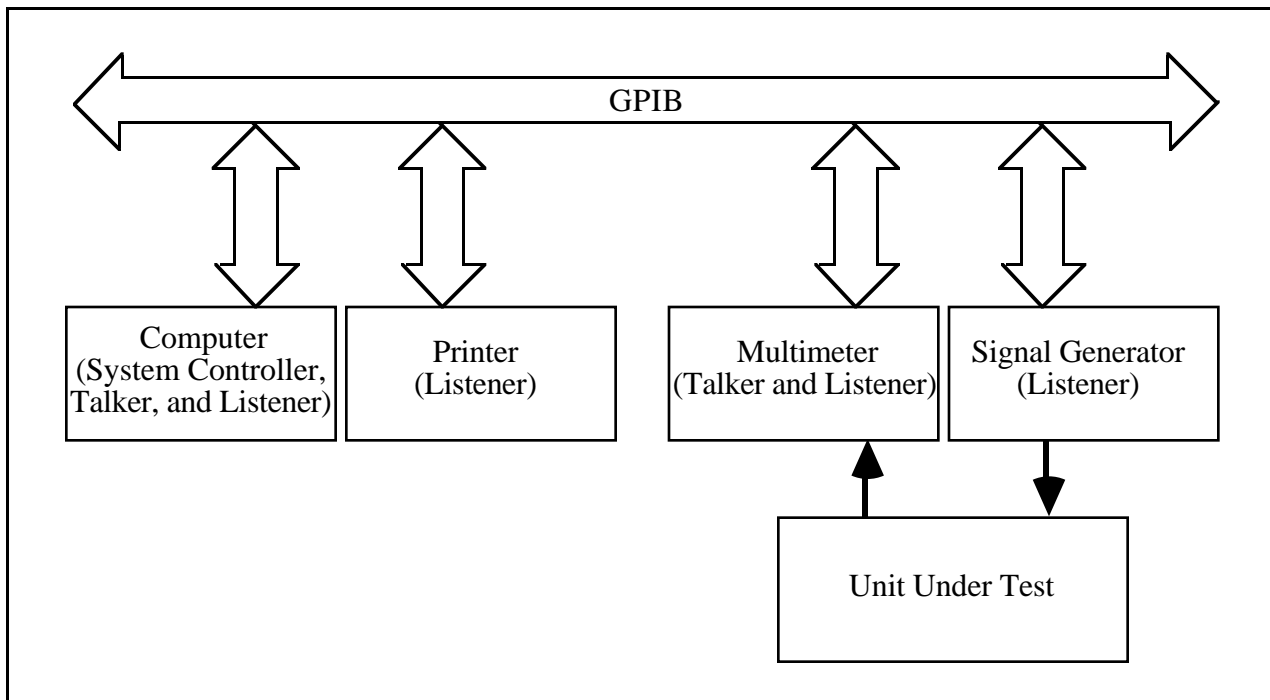

Figure 1-3. Typical GPIB-100A Extension System (Logical Configuration)

## GPIB-100A Specifications

The following tables show the system configuration; the performance, operating, electrical, environmental, and physical characteristics of the GPIB-100A, as well as providing a list of available GPIB-100A components and accessories.

Table 1-1. System Configuration Characteristics

Characteristic	Specification
distance per extension	up to 300 m
loading per extension	up to 14 additional devices
multiple extensions	permitted in any combination of star or linear pattern
GPIB driver output circuit and T1 timing of source device	no restrictions (automatic conversion to 2 $\mu$ sec T1 delay on remote side is built in)

**Note:** T1 is the data settling time (DIO valid to DAV) and varies according to the type of drivers and the system configuration used.

Table 1-2. Performance Characteristics

Characteristic	Specification
speed listeners	250 to 135 kbytes/sec (approximately 4 $\mu$ sec per byte degraded at 10.5 nsec per meter of distance) no limitation to device speeds when there are no on remote side of extension
functionality	transparent GPIB operation except for <i>pulsed</i> parallel polls
interlocked IEEE-488 handshake	maintained across the extension (message-grams not used)
IEEE-488 capability identification codes	SH1 complete Source Handshake AH1 complete Acceptor Handshake T5,TE5 complete Talker L3,LE3 complete Listener SR1 complete Service Request RL1 complete Remote Local PP1,2 complete Parallel Poll DC1 complete Device Clear DT1 complete Device Trigger C1-5 complete Controller E1 open collector GPIB drivers

Table 1-3. Operating Characteristics

Characteristic	Specification
architecture	asynchronous (no clock) parallel design point-to-point (not multi-drop) transmission
operating modes	Talker/Listener/Controller or Talker/Listener (Talk Only)
Parallel Poll Response modes	Buffered Parallel Poll Response or Unbuffered Parallel Poll Response

Table 1-4. Electrical Characteristics

<b>Characteristic</b>	<b>Specification</b>
GPIB interface circuit	duplex transceivers with open collector drivers (MC3441A)
transmission interface circuit	RS-422 drivers and receivers (MC3487 and AM26LS32) connected with patented data transmission cable for minimum skewing ( $\leq 3\%$ ) between any two pairs
power supply selectable (fuse)	50 to 60 Hz 110 V, 160 mA (250 mA, 250 V, Slow Blow) 220 V, 80 mA (200 mA, 250 V, Slow Blow)
GPIB interface load	one standard load, AC and DC
power	18 W typical

Table 1-5. Environmental Characteristics

<b>Characteristic</b>	<b>Specification</b>
operating temperature	0 to 55 C
humidity	5 to 95% non-condensing conditions
FCC	Class A verified
110V Version	UL Listed
220V Version	UL Listed and also classified by Underwriters Laboratories Inc. in accordance with International Electrotechnical Commission publication 950

Table 1-6. Physical Characteristics

Characteristic	Specification
case style	CS2
size	3.5 x 8.5 x 13 in. (89 x 216 x 330 mm)
case material	UL94V-0 flame retardant polystyrene Dow 60875 F or equivalent
rack mounting	single or dual kits available
GPIB cable	Hewlett Packard 10833 style or equivalent
Transmission cable	Dynatronics D-200-24 cable with AMP Amplimite connectors AMP HDP-20 50 pin connector with RFI/EMI shield

Table 1-7. Components and Accessories

Item	Part Number
Model GPIB-100A Bus Extender (110V) (two required per extension)	776107-01
Model GPIB-100A Bus Extender (220V) (two required per extension)	776107-31
Type T2 Transmission Cable	178056-xxx (xxx = length in meters)
Type X2 GPIB Cable 1 meter 2 meters 4 meters	763061-01 763061-02 763061-03
Single Rack-Mount Kit	180304-01
Dual Rack-Mount Kit	180304-02
<b>Note:</b> All part numbers in this table are National Instruments part numbers.	



# Chapter 2

## Installation

---

### Inspection

Inspect the shipping container and contents for evidence of physical damage or stress. If damage is discovered and appears to have been caused in shipment, file a claim with the carrier. If the equipment is damaged, do not attempt to operate it before contacting National Instruments for instructions. Retain the shipping material for possible inspection by carrier or reshipment of the equipment.

### Power Connection

The GPIB-100A Bus Extender is shipped from the factory set at a certain operating voltage, either 110 VAC or 220 VAC. Verify that the voltage you are using is the same as that selected on the rear panel of the GPIB-100A. Operating at a voltage other than the one selected may damage the unit. If the GPIB-100A is set at a voltage other than the one you are using, follow the steps below to change the operating voltage.

1. Remove the power cord from the unit.
2. Pull out the fuse holder and replace the fuse with one that has the type and rating specified in Table 1-4 for your operating voltage.
3. Using a small flat-head screwdriver, rotate the voltage selector to point to your operating voltage.

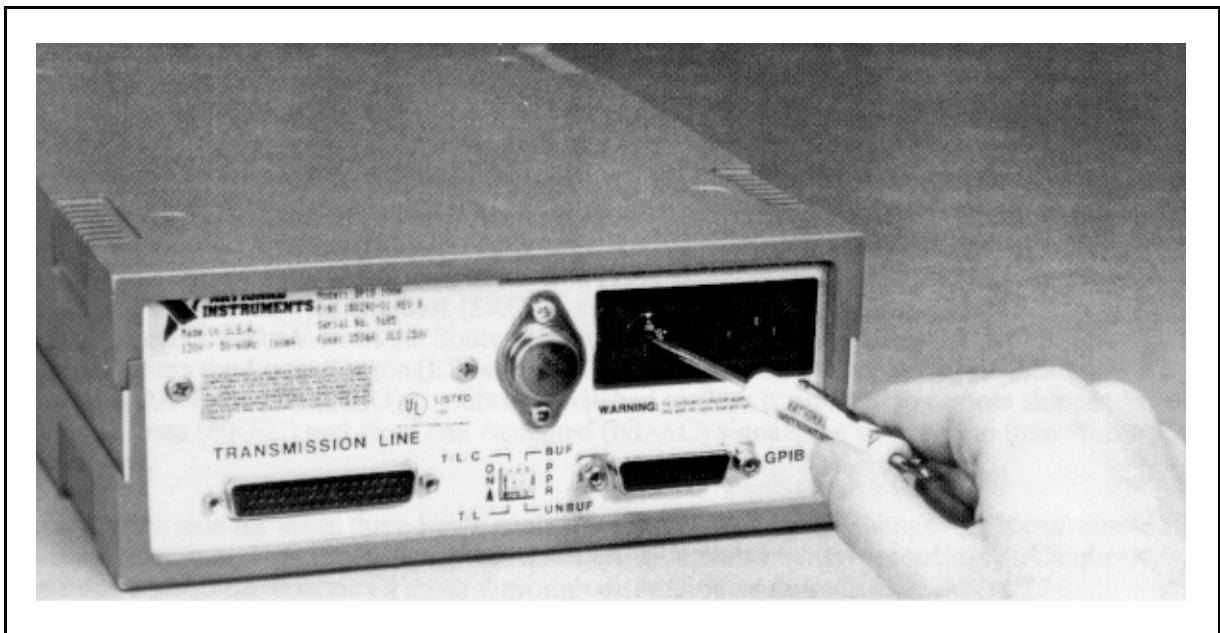

Figure 2-1. Voltage Selection

## Grounding Configuration

A U.S. standard three-wire power cable is provided with the GPIB-100A. When connected to a power source, this cable connects the equipment chassis to the power ground.

The GPIB-100A is shipped from the factory with chassis and power grounds connected to the logic ground of the digital circuitry and the shields of the interfacing cables. If it is necessary to isolate these grounds to prevent current loops between units, disassemble the unit according to the following instructions and remove jumper W1 located on the circuit card assembly near the back panel.

### Disassembly

The case consists of two identical sections. Before disassembling, remove power from the unit. Then remove the two screws on each side of the case and lift the top section. When reassembling, it may be necessary to adjust the two trim panels on the case side for proper fit in their grooves.

### Mounting

The GPIB-100A enclosure is designed for table top operation or for rack mounting. Single and dual unit rack mounting kits are available from National Instruments for field installation.

## Connecting to Hewlett-Packard Controllers

To achieve very high data transfer rates and long cable spans between devices, many Hewlett-Packard (HP) controllers and computers, such as the 64000 series, use a *preload* technique on the unit designated Master Controller. When preloaded, the GPIB lines of the Master Controller are terminated to represent six device loads. HP has two types of preloading: Class A, in which all 16 GPIB lines are loaded, and Class B, in which all lines except Not Ready For Data (NRFD) and Not Data Accepted (NDAC) are loaded.

Preloading increases ringing on signal transitions and may cause improper operation of the GPIB-100As. If this happens, all signals on the Master Controller should be set to normal (1 unit) load. This is done by means of a back panel switch when working from the exterior. In addition, the cabling rule of no more than 2m/device must be strictly enforced.

# Chapter 3

## Configuration and Operation

---

Users who are unfamiliar with the GPIB should first read Appendix A, *Operation of the GPIB*, to become familiar with GPIB terminology and protocol.

In the following discussions, the terms *local* and *remote* refer to certain states of the two GPIB-100A Bus Extenders in the system. When one extender is in a local state, meaning that the state in question originated on the local state's side, the other extender is in the corresponding remote state. The three states in question are the System Controller, Active Controller, and Source Handshake states.

### Operating Modes

The GPIB-100A has two operating modes: Talker/Listener/Controller mode and Talker/Listener mode. Both units in the extension system must be set to the same mode.

#### Talker/Listener/Controller (TLC) Mode

The GPIB-100A is set at the factory to the more common TLC operating mode. The TLC mode requires a System Controller on one side of the extension. There may be any number of Talkers, Listeners, and other Controllers in the system.

In the TLC mode, the two GPIB-100As expect to see in order: first the Interface Clear (IFC) signal from the System Controller; second the Attention (ATN) signal from the Active Controller; and third the Data Valid (DAV) signal from the Active Controller or Talker. A brief description of this mode is in the following paragraph.

Both units power up in a quiescent condition with no local or remote state active. They remain that way until one unit detects an IFC pulse from the System Controller which is on the same contiguous bus. That unit enters the Local System Controller (LSC) state and causes the other unit to enter the Remote System Controller (RSC) state. The IFC and Remote Enable (REN) signals are switched to flow from the local to the remote unit. Next, one unit detects the ATN signal from the Active Controller, enters the Local Active Controller (LAC) state, and places the other unit in the Remote Active Controller (RAC) state. The ATN signal is switched to flow from local to remote side and the Service Request (SRQ) is switched to flow in the opposite direction. Finally, one unit detects the DAV from the Source Handshake function of the Talker or Active Controller. That unit enters the Local Source (LS) state and places the other unit in the Remote Source (RS) state. The DAV and Data (DIO) signals are switched to flow from local to remote side, and the Not Ready for Data (NRFD) and Not Data Accepted (NDAC) signals are switched to flow from remote to local side.

As the source side for these three key signals—IFC, ATN, and DAV—change, the local/remote states of each extender and the directions of the other GPIB signals change accordingly. Chapter 4, *Theory of Operation*, contains a more thorough discussion of this.

## Talker/Listener (TL) Mode

There is no Controller and only one Talker in the TL mode of operation, sometimes called *talk only* mode. Usually, there is just one Listener as well. In the TL mode, the System and Active Controller states remain inactive and the IFC, REN, ATN, and SRQ signals are unused. The directions of the other signals are set the first time the Talker asserts DAV.

## Setting the Operating Mode

Both GPIB-100As in the extension system must be set to the same operating mode. Use switch S1, position 1, on the back panel of each GPIB-100A to set the operating mode. Set the switches as shown in Figure 3-1.

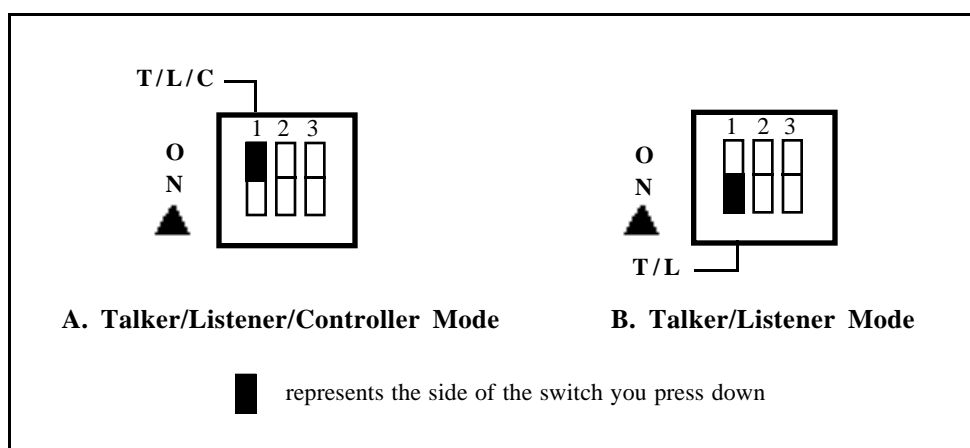

Figure 3-1. Switch Settings for Operating Mode

## Parallel Poll Response (PPR) Modes

According to ANSI/IEEE Standard 488-1978, devices must respond to a parallel poll within 200 nsec after the Identify (IDY) message (Attention (ATN) and End Or Identify (EOI)) is asserted by the Active Controller, which then waits until 2  $\mu$ sec or more to read the Parallel Poll Response (PPR). It is not possible for a remote device on an extended system to respond to this quickly because of cable propagation delay. GPIB extender manufacturers have approached this in three ways:

- Approach 1:      Respond to IDY within 200 nsec with the results of the previous poll of the remote bus.
- Approach 2:      Ignore the 200 nsec rule and assume the Controller will wait sufficiently long to capture the response.
- Approach 3:      Do not support parallel polling at all.

The GPIB-100A uses either Approach 1 or 2, selected at switch S1, position 3. Set this switch as shown in Figure 3-2.

## Buffered PPR Mode (Approach 1)

Most Controllers pulse the IDY signal for a period of time exceeding 2  $\mu$ sec and expect a response within that time. When used with this type of Controller, the GPIB-100A should be left in the Buffered PPR mode as set at the factory.

In this mode, the local GPIB-100A extender responds to IDY by outputting the contents of the PPR data register. At the same time, a parallel poll message is sent to the remote bus and the poll response is returned to the local unit in due course. When the local IDY signal is unasserted, the register is loaded with the new remote response. Consequently the register contains the response of the previous poll. To obtain the response of both local and remote buses, the control program executes two parallel polls back-to-back and uses the second response.

The software driver library of most Controllers contains an easy-to-use parallel poll function. If, for example, the function is called PPOLL and the control program is written in BASIC, the sequence to conduct a poll in Buffered PPR mode might be like this:

```
CALL PPOLL(PPR)
CALL PPOLL(PPR)
IF PPR > 0 GOTO NNN
```

If two GPIB extender systems are connected in series, three polls are necessary to get responses from the local, middle, and far buses.

## Unbuffered PPR Mode (Approach 2)

Many Hewlett-Packard GPIB Controllers remain in a parallel poll state with IDY asserted whenever they are not performing another function. A change in the response causes an interrupt of the control program. In other Controllers, the IDY signal is toggled on and off and the duration of the signal can be varied to accommodate delayed responses over extenders. When used with these types of Controllers, the GPIB-100A should be set to Unbuffered PPR mode. This means that the IDY message is sent to the remote bus and the response is returned as fast as propagation delays allow. The Controller must allow time to receive the response.

## Mixed Mode Operation

If there are multiple Controllers and all of the same type are located on the same side of the extension, the two GPIB-100A units can be set to Unbuffered and Buffered PPR modes accordingly.

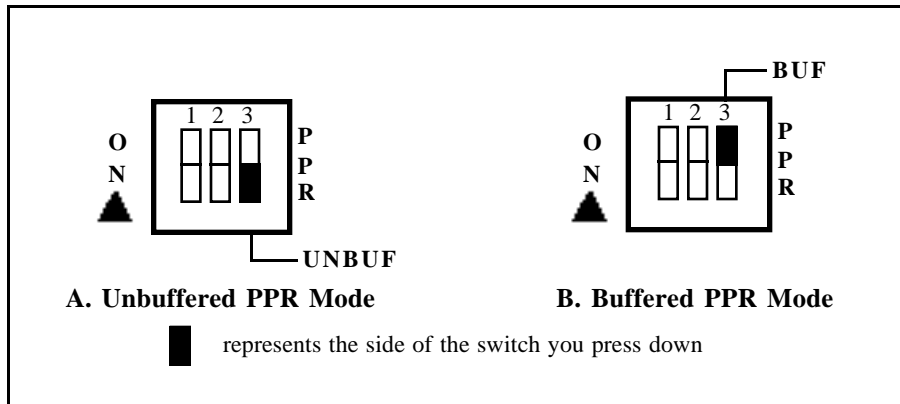

Figure 3-2. Switch Settings for Parallel Poll Response Mode

## Operating the GPIB-100A System

The GPIB-100A extension system is fully operational when power is applied to both units. In TLC mode, it is sometimes necessary to power on the System Controller last, after the extenders and all other devices are operating. This is necessary if the System Controller executes only one IFC shortly after power-on.

The preferred operating mode is to keep both extenders and at least two-thirds of the devices on both buses powered on when there is any GPIB activity.

# Chapter 4

## Theory of Operation

### Diagrams

Figure 4-1 shows a block diagram for the GPIB-100A. Refer to Appendix B for GPIB-100A schematic diagrams and Appendix C for the GPIB-100A parts locator diagram.

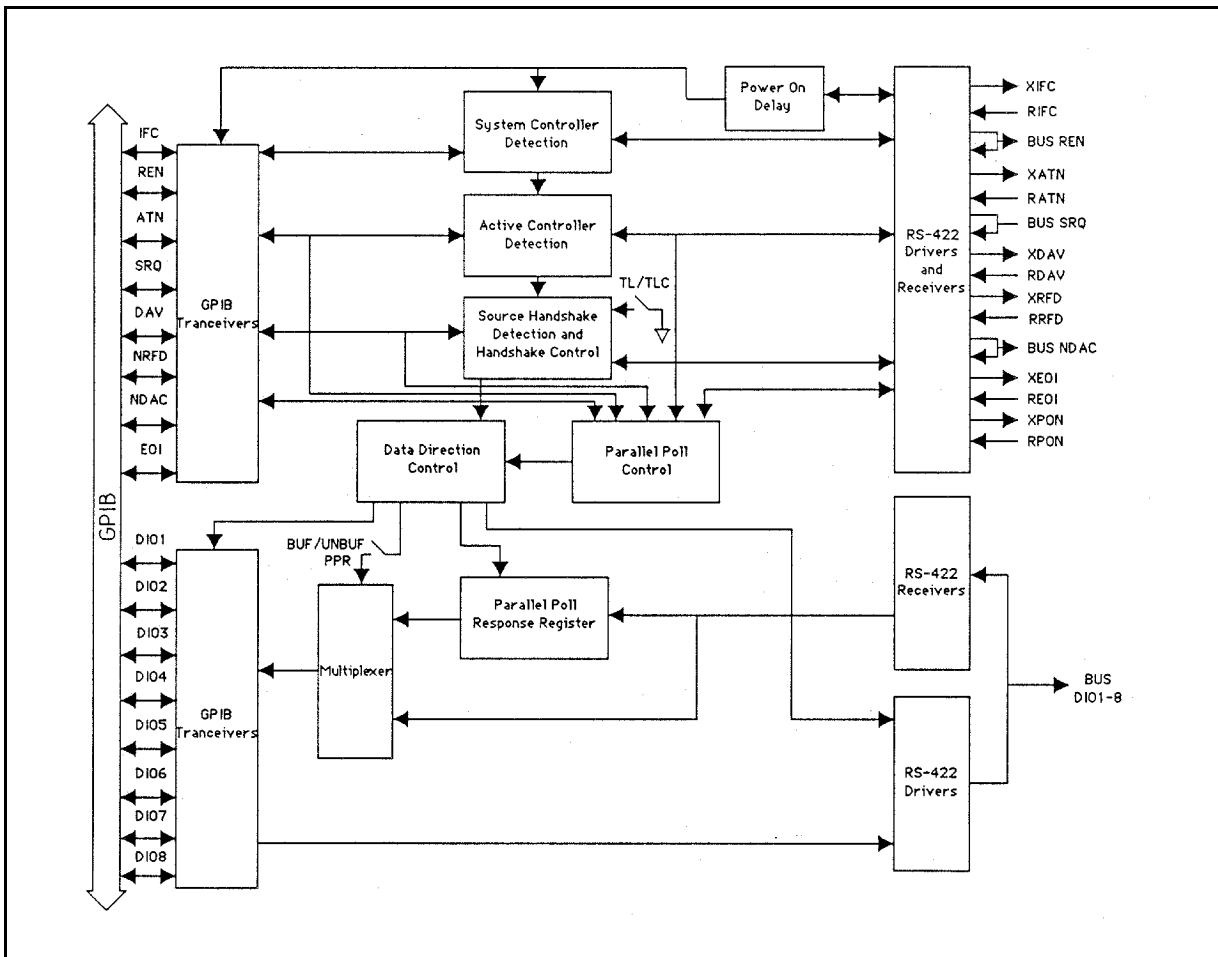

Figure 4-1. GPIB-100A Block Diagram

### Power-On

When the GPIB-100A is powered on, a reset pulse (PON) created by U48F, U28A/D and associated Register/Capacitor Delay (RCD) network directly or indirectly clears all flip-flops (FFs) to an initialized state. PON remains active until both units in the extension are powered on.

## System Controller Detection

PON initializes FFs U22A and U12A to clear the Remote System Controller (RSC) and Local System Controller (LSC) signals.

When Interface Clear (IFC) is received from the local side via GPIB transceiver U2B, the LSC FF is set on the leading edge of IFC and after a delay through U21B/C/D/E, IFC is enabled (U35D) to the remote unit as XIFC through driver U29A. LSC enables the local unit to transmit Remote Enable (REN) to the remote unit through driver U8A.

XIFC becomes RIFC on the remote side and is received through U10D and propagated to the remote GPIB through transceiver U2B, where the bus signal is received back to clock the RSC FF U22A. RSC enables REN (U32C) to be driven on the remote GPIB through transceiver U2D.

## Active Controller Detection

The Remote Active Controller (RAC) and Local Active Controller (LAC) FFs U22B and U12B remain cleared until either RSC or LSC is set via U41B—that is, until the System Controller has been located. After a short delay (U21A/F and U31B/F), the Attention (ATN) receiver on the local side (U32D) is enabled. This delay allows the LAC FF to be set if ATN is already asserted when IFC occurs.

When ATN is received from the local side via transceiver U2C, the LAC FF is set on the leading edge of ATN and, after a delay through U11B/C/D/E, ATN is enabled (U32A and U43D) to the remote unit as XATN through driver U29B. LAC enables the local unit to receive Service Request (SRQ) from the remote unit through receiver U10B, U32B, and transceiver U2A.

XATN becomes RATN on the remote side and is received through U20B and propagated to the remote GPIB through transceiver U2C, where the bus signal is received to clock RAC FF U22B.

When RAC is set, drivers U8C/D, which transmit SRQ and parallel poll handshake signal BUS PP to the local unit, are enabled (that is, toward the Active Controller).

## Source Handshake Detection

The Local Source (LS) handshake FF U45A is cleared via U33C on the following events:

- Before the Active Controller is identified (TLC mode only)
- Whenever a change in the state of the local ATN signal is caused by a pulse created via U38D, U24A/D, and associated RC network.
- While ATN or Data Valid (DAV) is received from the remote unit (U34B).
- During a parallel poll (U46C).

The Remote Source (RS) handshake FF U36B is cleared via U33B on the following events:

- Before the Active Controller is identified (TLC mode (U33A) only).



- Whenever a change in the state of the local ATN signal is caused by a pulse created via U38E, U24B/C, and associated RC network.
- While ATN or DAV is received from the local side (U34A/D).
- During a parallel poll (U38F and U34A).

Before the LS FF is set and unless a parallel poll is in progress, the unit drives the local Not Ready for Data (NRFD) signal passively false (U42C and U41C). After the Active Controller is identified and before the Source Handshake is identified, the unit drives Not Data Accepted (NDAC) signals (U42B and U41D) true. Thus, the unit appears in a normal RFD/NDAC state to the local GPIB which is awaiting the first data or command byte.

When DAV is received, it is first delayed slightly by U23A, U48E, and associated RCD network and enabled (U25A) to the LS FF. Setting the FF causes the Local Source Handshake to wait until ATN changes have propagated and any parallel poll completes fully. The purpose of the DAV delay is to filter tail-end unstable transitions from a fast rising edge. DAV is further delayed through U23B/C/E/F before being enabled at U25C by LS to be transmitted to the remote side as XDAV through driver U30B.

XDAV is received as RDAV on the remote side through U19D. The signal sets the RS FF after all clearing conditions are removed (U35B). DAV is delayed 2  $\mu$ sec or more through U38C, U48B, and associated RCD network to ensure proper data setup time (T1) on the remote side. Once RS is set and the remote GPIB is ready for data (U46A), DAV is allowed to propagate (U46D and U36C) to the remote GPIB through U47D, U27C, and GPIB transceiver U1B, and NRFD is transmitted to the other side through driver U30A (XRFD).

Once the LS FF is set, the propagation of NRFD from the remote side sets FF U36A via receiver U19A, U44C, and U35A. At this point, the unit drives the NRFD and NDAC lines according to the levels sensed at the remote unit (via U42C, U41A/D, and GPIB transceiver U1C for NDAC).

### Parallel Polling

When the local unit detects ATN and End Or Identify (EOI) asserted at the same time, regardless of which occurs first, FF U45D is set via U26A, U44E, U48D, and U43C. This causes EOI to be transmitted to the remote side as XEOI through U46B and driver U30C. ATN is also transmitted to the remote side as XATN through U43D and driver U29B. XEOI and XATN remain asserted until the poll signals propagate to the remote unit and a response is returned, even if the local signals become unasserted in the meantime. To prevent the local side from further non-poll activity, NRFD is asserted via U46C, U41C, and transceiver U1D.

If the Buffered PPR mode is selected, the contents of the PPR register (U16) are routed through the A side of multiplexers U13 and U14 to the local GPIB. The A side is selected whenever the local unit is not being polled from the other side (U27B) and the RS FF is cleared (U47A).

XEOI and XATN are received on the remote side as REOI and RATN through receivers U19B and U20B and propagated to the remote GPIB. Two microseconds later, a parallel poll handshake signal (U27C, U38A, and associated RCD network) is transmitted back to the local side through driver U8C as the signal BUS PP.

BUS PP is received at the local unit through U10C. When the local poll is over (ATN or EOI unasserted), FF U45B is cleared and U36D is set (via U37B/C and U26A). Setting U36D latches

the remote poll response into register U16. Clearing U45B unasserts XEOI and XATN, and after they propagate to the remote side, BUS PP is also unasserted. This causes FF U36D to be cleared as well, terminating the parallel poll process and removing the NRFD condition of the local extender.

To recap, FF U45B is set from the start of the local poll until the remote response is available and the local poll is over. FF U36D is set from the time U45B is cleared until the remote poll handshake is over. While either is set, the local unit remains in an NRFD holdoff.

## Data Direction Control

The unit drives the GPIB data lines DI01 to DI08 through transceivers U3 and U4 if there is a local parallel poll in progress (U47B and U26A) or if the RS FF is set and a remote parallel poll is not in progress (U47A and U27B). Otherwise, these lines are not driven.

The source for these data lines when they are driven is the remote unit through receivers U15 and U17 when Unbuffered PPR mode is selected (Switch S1, position 3 open) or when the RS FF is set and a remote parallel poll is not in progress (U47A and U27B). Otherwise, the source is the Buffered PPR register U16.

The unit drives the transmission data lines BUS DIO1-8 through drivers U5 and U7 if there is a remote parallel poll in progress (U37D and U27B) or if the LS FF is set and a local parallel poll is not in progress (U47C and U26A). Otherwise, these lines are not driven.

## EOI

The local unit transmits EOI to the remote side as XEOI if the LS FF is set (transceiver U1A, U25B, U46B, and driver U30C). Furthermore, XEOI is asserted from the start of a local parallel poll until the poll handshake signal BUS PP is received from the remote unit and the local poll stops.

XEOI is received as REOI at the remote unit through receiver U19B. It propagates to the remote GPIB if the local unit is conducting a parallel poll (U27A/B, U37A and transceiver U1A) or if the RS remote response (RR) is set and the local unit is not conducting a poll (U47A).

# Appendix A

## Operation of the GPIB

---

### History of the GPIB

The GPIB is a link, bus, or interface system through which interconnected electronic devices communicate. Hewlett-Packard invented the GPIB, which they call the HP-IB, to connect and control programmable instruments manufactured by them. Because of its high system data rate ceilings of from 250 kbytes/sec to 1 Mbytes/sec per second, the GPIB quickly became popular in other applications such as intercomputer communication and peripheral control. It was later accepted as the industry standard IEEE-488. The versatility of the system prompted the name General Purpose Interface Bus.

### Types of Messages

Devices on the GPIB communicate by passing messages through the interface system. There are two types of messages:

- Device-dependent messages, often called data or data messages, contain device-specific information such as programming instructions, measurement results, machine status, and data files.
- Interface messages manage the bus itself. They are usually called commands or command messages. Interface messages perform such functions as initializing the bus, addressing and unaddressing devices, and setting devices for remote or local programming.

**Note:** The term *command* as used here should not be confused with some device instructions which are also referred to as commands. Such device-specific instructions are actually data messages.

### Talkers, Listeners, and Controllers

There are three types of GPIB communicators. A Talker sends data messages to one or more Listeners. The Controller manages the flow of information on the GPIB by sending commands to all devices.

Devices can be Talkers, Listeners, and/or Controllers. A digital multimeter, for example, is a Talker and may also be a Listener. A printer or plotter is usually only a Listener. A computer on the GPIB often combines all three roles to manage the bus and communicate with other devices. The GPIB is a bus like a typical computer bus except that the computer has its circuit cards interconnected via a backplane bus whereas the GPIB has standalone devices interconnected via a cable bus.

The role of the GPIB Controller can also be compared to the role of the computer's CPU, but a better analogy is to the switching center of a city telephone system.

The switching center (Controller) monitors the communications network (GPIB). When the center (Controller) notices that a party (device) wants to make a call (send a data message), it connects the caller (Talker) to the receiver (Listener).

The Controller usually addresses a Talker and a Listener before the Talker can send its message to the Listener. After the message is transmitted, the Controller usually unaddresses both devices.

Some bus configurations do not require a Controller. For example, one device may only be a Talker (called a Talk-only device) and there may be one or more Listen-only devices.

A Controller is necessary when the active or addressed Talker or Listener must be changed. The Controller function is usually handled by a computer.

## System Controller and Active Controller

Although there can be multiple Controllers on the GPIB, only one Controller at a time is Active Controller or Controller-in-Charge (CIC). Active control can be passed from the current Active Controller to an idle Controller. Only one device on the bus, the System Controller, can make itself the Active Controller.

## GPIB Signals

The interface bus consists of 16 signal lines and 8 ground return or shield drain lines. The 16 signal lines are divided into three groups:

- 8 data lines
- 3 handshake lines
- 5 interface management lines

Figure A-1 shows the arrangement of these signals on the GPIB cable connector.

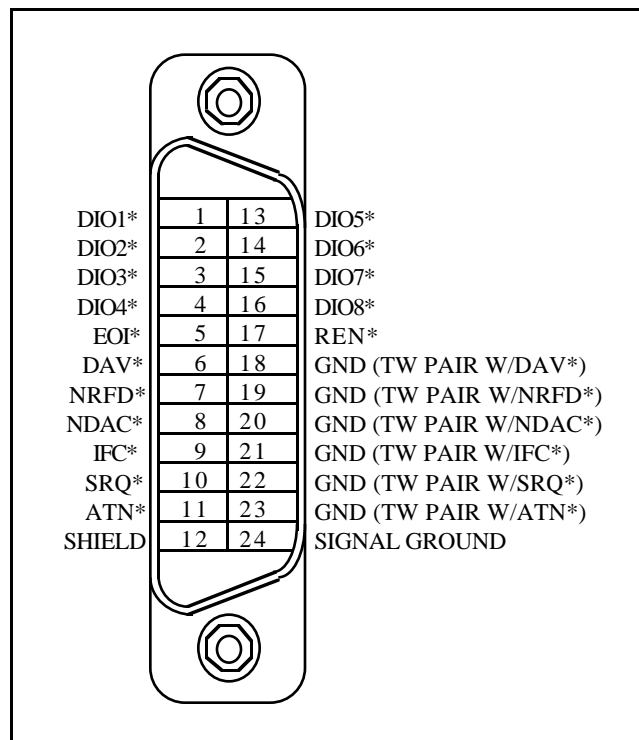

Figure A-1. GPIB Cable Connector

## Data Lines

The eight data lines, DIO1 through DIO8, carry both data and command messages. All commands and most data use the 7-bit ASCII or ISO code set, in which case the eighth bit, DIO8, is unused or used for parity.

Appendix E lists the GPIB command messages.

## Handshake Lines

Three lines asynchronously control the transfer of message bytes among devices. The process is called a three-wire interlocked handshake and it guarantees that message bytes on the data lines are sent and received without transmission error.

### NRFD (not ready for data)

NRFD indicates when a device is ready or not ready to receive a message byte. The line is driven by all devices when receiving commands and by Listeners when receiving data messages.

**NDAC (not data accepted)**

NDAC indicates when a device has or has not accepted a message byte. The line is driven by all devices when receiving commands and by Listeners when receiving data messages.

**DAV (data valid)**

DAV tells when the signals on the data lines are stable (valid) and can be accepted safely by devices. The Controller drives DAV when sending commands, and the Talker drives it when sending data messages.

The way in which NRFD and NDAC are used by the receiving device is called the Acceptor Handshake. Likewise, the sending device uses DAV in the Source Handshake.

**Interface Management Lines**

Five lines are used to manage the flow of information across the interface.

**ATN (attention)**

The Controller drives ATN true when it uses the data lines to send commands and false when it allows a Talker to send data messages.

**IFC (interface clear)**

The System Controller drives the IFC line to initialize the bus to become Controller-In-Charge.

**REN (remote enable)**

The System Controller drives the REN line, which is used to place devices in remote or local program mode.

**SRQ (service request)**

Any device can drive the SRQ line to asynchronously request service from the Active Controller with the SRQ line.

**EOI (end or identify)**

The EOI line has two purposes. The Talker uses the EOI line to mark the end of a message string. The Active Controller uses the EOI line to tell devices to identify their responses in a parallel poll.

## Physical and Electrical Characteristics

Devices are usually connected with a cable assembly consisting of a shielded 24-conductor cable with both a plug and receptacle at each end. This design allows devices to be connected in either a linear or a star configuration, or a combination of the two. See Figures A-2 and A-3.

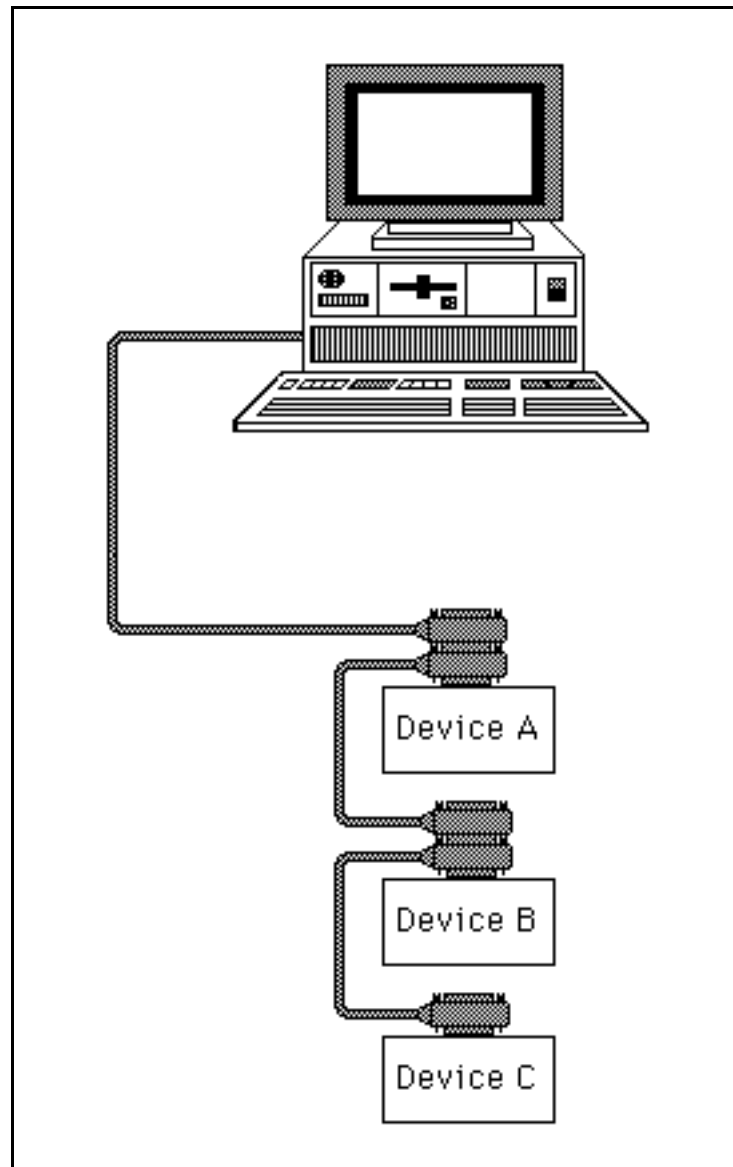

Figure A-2. Linear Configuration of the GPIB Devices

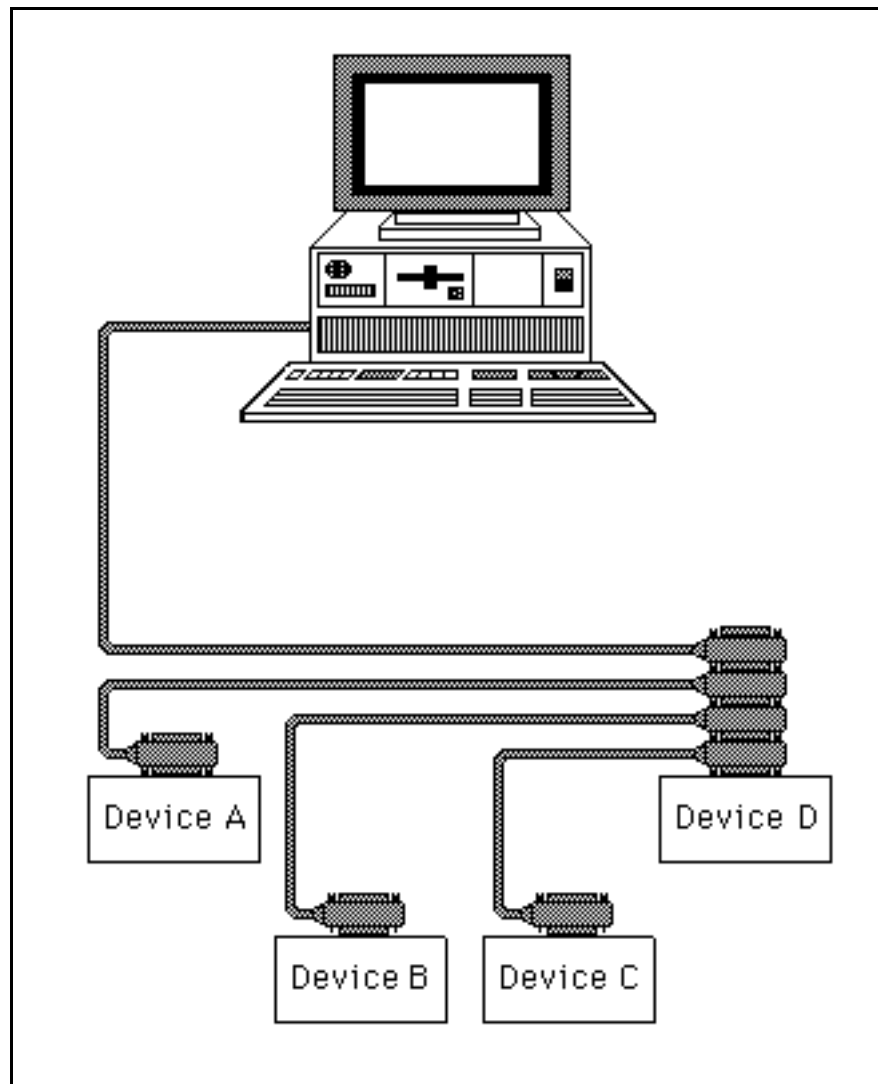

Figure A-3. Star Configuration of GPIB Devices

The standard connector is the Amphenol or Cinch Series 57 MICRORIBBON or AMP CHAMP type. An adapter cable using non-standard cable and/or connector is used for special interconnect applications.

The GPIB uses negative logic with standard TTL logic levels. When DAV is true, for example, it is a TTL low level ( $\leq 0.8$  V), and when DAV is false, it is a TTL high level ( $\geq 2.0$  V).



## Configuration Restrictions

To achieve the high data transfer rate that the GPIB is designed for, the physical distance between devices and the number of devices on the bus is limited.

The following restrictions are typical:

- A maximum separation of 4 m between any two devices and an average separation of 2 m over the entire bus.
- A maximum total cable length of 20 m.
- No more than 15 devices connected to each bus, with at least two-thirds powered-on.

It is usually possible to connect a cluster of lab instruments without exceeding these restrictions. But many applications require longer cable spans or additional loading. From the time the GPIB was invented, the need has existed for bus extenders and expanders (repeaters).

Extenders connect two separate buses via a transmission medium and the distance between the buses can be quite long. Expanders allow up to 14 additional devices to be connected to the bus and 20 meters of cable length to be added to the system.

National Instruments provides two extenders which allow longer cable spans. These products are the GPIB-100A and the GPIB-110. Both must be used in pairs, one at each end of the extension cable. The GPIB-100A, a parallel extender, relays the instantaneous status of all GPIB signals over an RS-422-compatible cable. The GPIB-100A allows up to a 300-meter extension. The GPIB-110, a serial extender, samples the GPIB signals, encodes the information into small packets, and transmits the packets on either a low-cost coaxial cable, or a high performance electrically isolated fiber-optic cable. The GPIB-110 allows up to a 2-kilometer extension.

The GPIB-100A is the only parallel extender on the market today. The instantaneous status of all GPIB signals on one side are relayed over individual RS-422 circuits to the other side. This approach makes the GPIB-100A the fastest and most transparent of all extenders available. The parallel design however, requires bulkier and more costly cable than serial designs.

# Appendix B

## Schematic Diagram

---

This appendix contains the schematic diagram for the GPIB-100A.



# Appendix C

## GPIB-100A Parts Locator Diagram

This appendix contains the parts locator diagram for the GPIB-100A. The parts locator diagram shows the locations of the GPIB-100A configuration jumpers and switches.

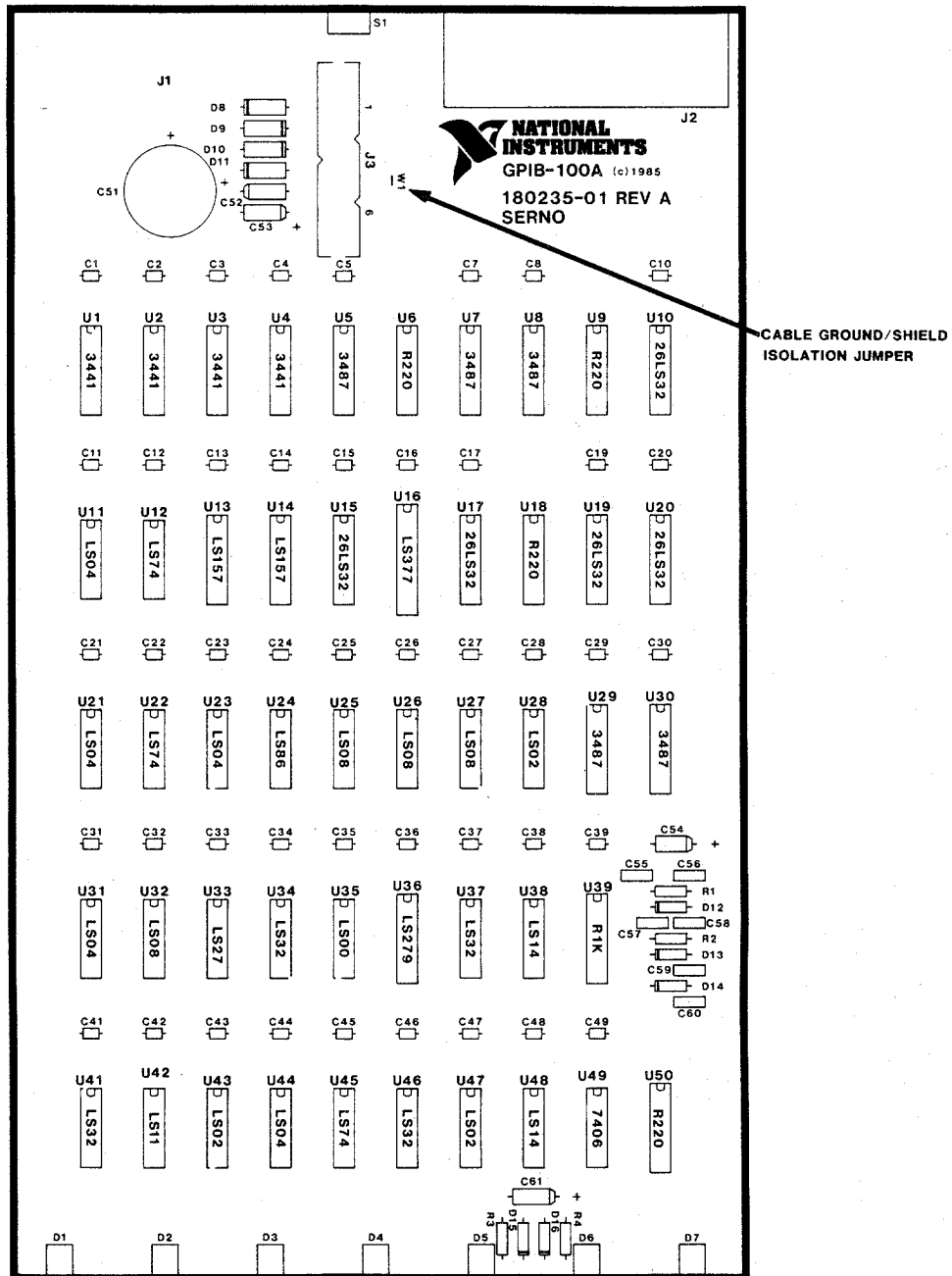

Figure C-1. GPIB-100A Parts Locator Diagram

# Appendix D

## Cable Assembly Wire List

---

This appendix contains the wire list for the GPIB-100A Transmission Cable.

Connector P2A		Cable		Connector P2B	
Signature	Pin No.	Pair No.	Color	Signature	Pin No.
D101	44	1	GRN	D101	44
D101	43		WT	D101	43
D102	34	2	GRN	D102	34
D102	41		WT	D102	41
D103	48	3	GRN	D103	48
D103	47		WT	D103	47
D104	36	4	GRN	D104	36
D104	39		WT	D104	39
D105	42	5	GRN	D105	42
D105	18		WT	D105	18
D106	45	6	GRN	D106	45
D106	46		WT	D106	46
D107	40	7	GRN	D107	40
D107	35		WT	D107	35
D108	37	8	GRN	D108	37
D108	38		WT	D108	38
BUS SRQ	30	9	GRN	BUS SRQ	30
BUS SRQ	32		WT	BUS SRQ	32
BUS REN	14	10	GRN	BUS REN	14
BUS REN	15		WT	BUS REN	15
BUSPP	16	11	GRN	BUSPP	16
BUSPP	17		WT	BUSPP	17
XIFC	29	12	GRN	RIFC	31
XIFC	12		WT	RIFC	33
RIFC	31	13	GRN	XIFC	29
RIFC	33		WT	XIFC	12
XATN	27	14	GRN	RATN	8
XATN	11		WT	RATN	1
XRFD	21	15	GRN	RRFD	3
XRFD	22		WT	RRFD	6
RRFD	3	16	GRN	XRFD	21
RRFD	6		WT	XRFD	22
BUSDAC	5	17	GRN	BUSDAC	5
BUSDAC	28		WT	BUSDAC	28
XEOI	25	18	GRN	REOI	2
XEOI	9		WT	REOI	7
REOI	2	19	GRN	XEOI	25
REOI	7		WT	XEOI	9
XDAV	10	20	GRN	RDAV	4
XDAV	26		WT	RDAV	13
RDAV	4	21	GRN	XDAV	10
RDAV	13		WT	XDAV	26
XPON	24	22	GRN	RPON	20
XPON	23		WT	RPON	19
RATN	8	23	GRN	XATN	27
RATN	1		WT	XATN	11
RPON	20	24	GRN	XPON	24
RPON	19		WT	XPON	23
SHIELD	49			SHIELD	49
SHIELD	50			SHIELD	50

# Appendix E

## Multiline Interface Command Messages

---

The following tables are multiline interface messages (sent and received with ATN TRUE).

## Multiline Interface Messages

Hex	Oct	Dec	ASCII	Msg	Hex	Oct	Dec	ASCII	Msg
00	000	0	NUL		20	040	32	SP	MLA0
01	001	1	SOH	GTL	21	041	33	!	MLA1
02	002	2	STX		22	042	34	"	MLA2
03	003	3	ETX		23	043	35	#	MLA3
04	004	4	EOT	SDC	24	044	36	\$	MLA4
05	005	5	ENQ	PPC	25	045	37	%	MLA5
06	006	6	ACK		26	046	38	&	MLA6
07	007	7	BEL		27	047	39	'	MLA7
08	010	8	BS	GET	28	050	40	(	MLA8
09	011	9	HT	TCT	29	051	41	)	MLA9
0A	012	10	LF		2A	052	42	*	MLA10
0B	013	11	VT		2B	053	43	+	MLA11
0C	014	12	FF		2C	054	44	,	MLA12
0D	015	13	CR		2D	055	45	-	MLA13
0E	016	14	SO		2E	056	46	.	MLA14
0F	017	15	SI		2F	057	47	/	MLA15
10	020	16	DLE		30	060	48	0	MLA16
11	021	17	DC1	LLO	31	061	49	1	MLA17
12	022	18	DC2		32	062	50	2	MLA18
13	023	19	DC3		33	063	51	3	MLA19
14	024	20	DC4	DCL	34	064	52	4	MLA20
15	025	21	NAK	PPU	35	065	53	5	MLA21
16	026	22	SYN		36	066	54	6	MLA22
17	027	23	ETB		37	067	55	7	MLA23
18	030	24	CAN	SPE	38	070	56	8	MLA24
19	031	25	EM	SPD	39	071	57	9	MLA25
1A	032	26	SUB		3A	072	58	:	MLA26
1B	033	27	ESC		3B	073	59	;	MLA27
1C	034	28	FS		3C	074	60	<	MLA28
1D	035	29	GS		3D	075	61	=	MLA29
1E	036	30	RS		3E	076	62	>	MLA30
1F	037	31	US		3F	077	63	?	UNL

### Message Definitions

DCL	Device Clear	MSA	My Secondary Address
GET	Group Execute Trigger	MTA	My Talk Address
GTL	Go To Local	PPC	Parallel Poll Configure
LLO	Local Lockout	PPD	Parallel Poll Disable
MLA	My Listen Address		



## Multiline Interface Messages

Hex	Oct	Dec	ASCII	Msg	Hex	Oct	Dec	ASCII	Msg
40	100	64	@	MTA0	60	140	96	`	MSA0,PPE
41	101	65	A	MTA1	61	141	97	a	MSA1,PPE
42	102	66	B	MTA2	62	142	98	b	MSA2,PPE
43	103	67	C	MTA3	63	143	99	c	MSA3,PPE
44	104	68	D	MTA4	64	144	100	d	MSA4,PPE
45	105	69	E	MTA5	65	145	101	e	MSA5,PPE
46	106	70	F	MTA6	66	146	102	f	MSA6,PPE
47	107	71	G	MTA7	67	147	103	g	MSA7,PPE
48	110	72	H	MTA8	68	150	104	h	MSA8,PPE
49	111	73	I	MTA9	69	151	105	i	MSA9,PPE
4A	112	74	J	MTA10	6A	152	106	j	MSA10,PPE
4B	113	75	K	MTA11	6B	153	107	k	MSA11,PPE
4C	114	76	L	MTA12	6C	154	108	l	MSA12,PPE
4D	115	77	M	MTA13	6D	155	109	m	MSA13,PPE
4E	116	78	N	MTA14	6E	156	110	n	MSA14,PPE
4F	117	79	O	MTA15	6F	157	111	o	MSA15,PPE
50	120	80	P	MTA16	70	160	112	p	MSA16,PPD
51	121	81	Q	MTA17	71	161	113	q	MSA17,PPD
52	122	82	R	MTA18	72	162	114	r	MSA18,PPD
53	123	83	S	MTA19	73	163	115	s	MSA19,PPD
54	124	84	T	MTA20	74	164	116	t	MSA20,PPD
55	125	85	U	MTA21	75	165	117	u	MSA21,PPD
56	126	86	V	MTA22	76	166	118	v	MSA22,PPD
57	127	87	W	MTA23	77	167	119	w	MSA23,PPD
58	130	88	X	MTA24	78	170	120	x	MSA24,PPD
59	131	89	Y	MTA25	79	171	121	y	MSA25,PPD
5A	132	90	Z	MTA26	7A	172	122	z	MSA26,PPD
5B	133	91	[	MTA27	7B	173	123	{	MSA27,PPD
5C	134	92	\	MTA28	7C	174	124		MSA28,PPD
5D	135	93	]	MTA29	7D	175	125	}	MSA29,PPD
5E	136	94	^	MTA30	7E	176	126	~	MSA30,PPD
5F	137	95	_	UNT	7F	177	127	DEL	

PPE Parallel Poll Enable  
 PPU Parallel Poll Unconfigure  
 SDC Selected Device Clear  
 SPD Serial Poll Disable

SPE Serial Poll Enable  
 TCT Take Control  
 UNL Unlisten  
 UNT Untalk

# Appendix F

## Mnemonics Key

---

This appendix contains a mnemonics key that defines the mnemonics (abbreviations) used throughout this manual.

<b>Mnemonic</b>	<b>Definition</b>
ASCII	American Standard Code for Information Interchange
ATN	Attention
C	Controller
CIC	Controller-In-Charge Bit
DAV	Data Valid
DIO	Data
EOI	End or Identify Bit
FF	Flip-flop
IDY	Identify
IFC	Interface Clear
ISO	International Standard code set
L	Listener
LAC	Local Active Controller
LS	Local Source
LSC	Local System Controller
NDAC	GPIB Not Data Accepted line status Bit
NRFD	GPIB Not Ready For Data line status Bit
PON	Power-On Reset Pulse
PP	Parallel Poll (scan all status flags)
PPR	Parallel Poll Response
RAC	Remote Active Controller
RCD	Resistor/Capacitor Delay

<b>Mnemonic</b>	<b>Definition</b>
REN	Remote Enable
RFD	Ready for Data
RR	Remote Response
RS	Remote Source
RSC	Remote System Controller
SRQ	Service Request
T	Talker
TL	Talker/Listener
TLC	Talker/Listener/Controller (GPIB Adapter)
TTL	Transistor/Transistor Logic

# User Comment Form

---

National Instruments encourages you to comment on the documentation supplied with our products. This information helps us provide quality products to meet your needs.

Title: **GPIB-100A User Manual**

Edition Date **March 1990**

Part Number: **320063-01**

Please comment on the completeness, clarity, and organization of the manual.

---

---

---

---

---

---

---

---

If you find errors in the manual, please record the page numbers and describe the errors.

---

---

---

---

---

---

---

---

Thank you for your help.

Name \_\_\_\_\_

Title \_\_\_\_\_

Company \_\_\_\_\_

Address \_\_\_\_\_

\_\_\_\_\_

Phone ( \_\_\_\_\_ ) \_\_\_\_\_

Mail to: Technical Publications  
National Instruments Corporation  
6504 Bridge Point Parkway, MS 53-02  
Austin, TX 78730-5039



## Artisan Technology Group is your source for quality new and certified-used/pre-owned equipment

- FAST SHIPPING AND DELIVERY
- TENS OF THOUSANDS OF IN-STOCK ITEMS
- EQUIPMENT DEMOS
- HUNDREDS OF MANUFACTURERS SUPPORTED
- LEASING/MONTHLY RENTALS
- ITAR CERTIFIED SECURE ASSET SOLUTIONS

### SERVICE CENTER REPAIRS

Experienced engineers and technicians on staff at our full-service, in-house repair center

### *InstraView*<sup>SM</sup> REMOTE INSPECTION

Remotely inspect equipment before purchasing with our interactive website at [www.instraview.com](http://www.instraview.com) ↗

### WE BUY USED EQUIPMENT

Sell your excess, underutilized, and idle used equipment. We also offer credit for buy-backs and trade-ins. [www.artisanng.com/WeBuyEquipment](http://www.artisanng.com/WeBuyEquipment) ↗

### LOOKING FOR MORE INFORMATION?

Visit us on the web at [www.artisanng.com](http://www.artisanng.com) ↗ for more information on price quotations, drivers, technical specifications, manuals, and documentation

**Contact us:** (888) 88-SOURCE | [sales@artisanng.com](mailto:sales@artisanng.com) | [www.artisanng.com](http://www.artisanng.com)