



Artisan Technology Group is your source for quality new and certified-used/pre-owned equipment

- FAST SHIPPING AND DELIVERY
- TENS OF THOUSANDS OF IN-STOCK ITEMS
- EQUIPMENT DEMOS
- HUNDREDS OF MANUFACTURERS SUPPORTED
- LEASING/MONTHLY RENTALS
- ITAR CERTIFIED SECURE ASSET SOLUTIONS

SERVICE CENTER REPAIRS

Experienced engineers and technicians on staff at our full-service, in-house repair center

*InstraView*SM REMOTE INSPECTION

Remotely inspect equipment before purchasing with our interactive website at www.instraview.com ↗

WE BUY USED EQUIPMENT

Sell your excess, underutilized, and idle used equipment. We also offer credit for buy-backs and trade-ins. www.artisanng.com/WeBuyEquipment ↗

LOOKING FOR MORE INFORMATION?

Visit us on the web at www.artisanng.com ↗ for more information on price quotations, drivers, technical specifications, manuals, and documentation

Contact us: (888) 88-SOURCE | sales@artisanng.com | www.artisanng.com

P325 User Guide

Low EMI Microstep Power/Drive

Installation and User

Reference Manual



AMERICAN PRECISION INDUSTRIES, INC.

CONTROLS DIVISION
4401 Genesee Street
Buffalo, New York 14225
(716) 631-9800

1 GETTING STARTED

Our goal as a supplier is to provide the user with the proper tools to get his/her application up and running as quickly as possible. This includes designing products that are easy to learn, use, install, and maintain, in addition to providing the required documentation and support to quickly answer any questions that you might have. To help you get started, this section will provide you with a roadmap through this manual. Depending on your level of expertise, you can decide how to proceed. We hope you find our recommendations helpful and we welcome any comments/suggestions that you might have in helping us achieve our goal.

The primary intention of this manual is to guide the first time user of the P325 Series packages through the familiarization and installation into the chosen application. After the initial installation is accomplished it can also serve as an ongoing reference manual for installation changes or future reference needs.

While this manual is intended to include as much available information as possible, it is designed to also be easy to use for those who will not be reading the entire manual or who only want to refer to specific sections. Users should classify themselves and proceed accordingly:

First time users -

We recommend that all first time users and those basically unfamiliar with step motor drives read the entire manual before proceeding with installation.

Experienced users -

Refer to the Precautions in SECTION 2 and to the Summary in SECTION 4 before proceeding with your installation.

Current users with specific information needs -

The comprehensive index contained in SECTION 3 will guide you to the specific location with answers to your questions.

2 PRECAUTIONS AND WARNINGS

While we have designed these drives with safety issues in mind, the user should keep the following precautions in mind:

- > Because potentially hazardous voltages can be present around this drive, only qualified service and installation personnel should install this device.
- > All connections or changes to the drive configuration should be made with any power sources turned off and disconnected from the drive.

3 TABLE OF CONTENTS

<u>SECTION</u>	<u>PAGE</u>
1 GETTING STARTED	1
2 PRECAUTIONS AND WARNINGS	1
3 TABLE OF CONTENTS	2
4 SUMMARY OF OPERATIONS	3
5 UNPACKING AND INSPECTION	4
6 DESCRIPTION OF OPERATION	5
7 MOTOR COMPATIBILITY	6
8 DRIVE CONFIGURATION AND CONNECTIONS	7
8.1 Drive Configuration	7
8.1.1 Introduction	7
8.1.2 Low Voltage Adjustment	7
8.1.3 Current Switch Settings	8
8.1.4 Current Profile Settings	9
8.1.5 Microstep Resolution Switch Settings	9
8.2 Drive Connections	10
8.2.1 Introduction	10
8.2.2 Motor Connections	10
8.2.3 Logic Connections	11
8.2.4 Power Connections	12
9 INSTALLATION	12
9.1 Cooling	12
9.2 Mounting	12
9.3 Drive Configuration	13
9.4 Drive Connections	13
9.5 Applying Power	13
10 PERFORMANCE EXPECTATIONS	14
11 P325 SPECIFICATIONS	15
12 TROUBLESHOOTING	16
13 VELOCITY CONTROL OSCILLATOR OPTION (P325V)	18
13.1 Description	18
13.2 P325V Logic Connections	18
13.3 Adjustments	20
13.4 VCO Specifications	21
14 APPENDIX A API Motor Listing	22
15 APPENDIX B Dip Switch Settings	23
16 APPENDIX C Performance Curves	25

4 SUMMARY OF OPERATIONS

This section is provided only for those who either have experience with step motor drives or wish to learn the minimum required to hook-up and run the P325 Series step motor drives. An assumption is made here that the user has a pulse train available to supply to the drive. If not, then other sections of the manual should be referred to as required.

The P325 Series is a bilevel voltage step motor drive with microstepping capability. By microstepping a step motor, its motion can be dramatically smoothed and the positioning resolution greatly enhanced without sacrificing its other attractive features. Microstepping involves taking each of the motor's mechanical full steps and electrically creating many finer ones by precisely controlling the current flow to each of the windings. The P325 series will drive 4-phase motors rated at up to 4.0 Amps per phase (bifilar rating). The basic installation steps include:

- 1) Ensure that the AC power source is 115 VAC.
- 2) Read Section 8 - Drive Configuration and Connections
- 3) Ensure the Low Voltage Adjustment is properly set (Section 8.1.2)
- 4) Ensure that the drive current switch settings are set for the motor that you are running (Section 8.1.3).
- 5) Verify the Current Profile Settings (Section 8.1.4).
- 6) Select the Microstep Resolution desired (Section 8.1.5).
- 7) Plug the motor connector into the socket labeled motor (Section 8.2.2).
- 8) Connect the required logic control lines (Section 8.2.3).
- 9) Plug into your power source (Section 8.2.4).
- 10) Supply control signals to the drive. The type of control utilized to supply step, direction and other control signals to the drive depends on the application and the available equipment. Methods offered by the Controls Division include the VCO option on the P325 (Section 13), and the SAC-560 Smart Axis Controller. Another option is for the user to supply the required signals directly from his system. A brief synopsis of each option follows:

CONTROL SIGNALS:

USER INPUT

This is a valid option when the user system already contains a computer or programmable logic controller. With this method, the user provides TTL inputs directly to the step motor drive to control motion in the system. As a bare minimum, step and depending on the application direction inputs must be provided to the step motor drive. Additionally, many applications will require efficient ramp routines to achieve the performance objectives of the system. It is the responsibility of the user when this is the selected method of control.

SAC-560

Select this option when the user's system does not contain a logic device; the motion sequences are complex; the motion sequences are changing frequently; or if performance requirements are demanding. The SAC-560 is a self-contained, high speed microprocessor based controller. Features include RS-232 communications, programmable inputs and outputs that interface to external devices, and an English-like command language. Ramping routines are automatically generated and/or can be placed under user control.

VCO OPTION (P325V)

Select this option when motion in the system is fixed and logic is available to provide for timing of the Run, Accel, Decel and Stop signals required by this device. When signals are received, the VCO board will generate pulses to the motor at the rate established by the onboard Base, Slew, Accel and Decel potentiometers. These potentiometers are preset by the user and require manual adjustment, (Section 13).

5 UNPACKING AND INSPECTION

Carefully remove the contents of the carton in which the driver was shipped. Inspect the carton and the drive and make note of any apparent physical damage. If severe damage is present then you should consider rejecting the shipment and making contact with the shipping company concerning in-transit damage claims. We have made every effort at the factory before shipment to fully inspect, test, and properly package this product so that it reaches you defect free and without damage.

All packaging materials should be saved and set aside in case a return shipment has to be made. The contents may include connectors, mounting screws, a motor, or other components - please compare these components to the parts list which is included on the shipper. Immediately report any discrepancies to the shipping location.

6 DESCRIPTION OF OPERATION

Functional Overview

The P325 Series are driver and power supply units that combines bilevel voltage drive technology with an integral linear power section. Each model includes a motor, drive, linear power supply, integral heatsink, power cord, connectors and a full enclosure. The P325 Series packages are directly compatible with the Controls Division's Indexers/Controllers for a total motion system solution.

All models contain the logic and power switching stages required to operate a large percentage of existing step motor designs. The logic section of the drive acts to direct current in and out of the motor phases in a proper sequence in order to cause the desired rotation.

The power switching stage controls the rate and amount of current flow into the motor windings as directed by the logic. In general, the faster the current is pumped through a winding during each step, the more torque and speed that will be obtained. The P325 Series uses a bilevel voltage method of current control which will yield excellent speeds and torques. This technique involves overdriving the windings with a high voltage to decrease the current rise times, and then reducing the voltage to provide a constant current to the motor windings.

The inputs to the drives have been designed to handle many configurations (see Section 8 for technical descriptions):

Power

The required AC power is 115 Volts, 60 Hz.
5 VDC, 100 milliamps for the optically isolated inputs.

Motor

Either 6 or 8 lead hybrid motor leads can be connected to the drive. (See Section 7 for details)

Pulse Source

The P325 Series accept pulse and direction control inputs from a wide variety of sources. See Section 4 for optional methods of supplying control signals to the drive. The maximum rate of pulses accepted is 1.0 MHz, or 1,000,000 pulses per second.

Other Control Features

The no-power input is used to control a power down state, disabling the motor. The low-power input is used to reduce the current to one-third full power. The microstep resolution, current profile and current supplied to the motor are controlled by setting dip switches on the drive.

7 MOTOR COMPATIBILITY

The P325 Series is capable of running a wide range of step motors with its bilevel voltage switching technique. The limits of these ranges fall into several categories:

Winding Type

The motor winding type should be basically a four phase motor which is capable of unipolar operation, characterized by the need for current to flow in only one direction in each coil of the motor. Most motors which fall into the "HYBRID" motor classification will work. Step angles of 0.9 and 1.8 degrees are the most common. Other step angles will also work. Appendix A lists the most common motors available through the Controls Division of API.

Number of Leads

Hybrid style motors have 4, 6, or 8 leads depending on how they are wound and connected. Diagram 7.1 shows these 3 basic configurations; note that the 4-lead motor is wound in a "UNIFILAR" fashion while the 6 and 8 lead motors are wound in a "BIFILAR" fashion. ONLY 6 OR 8 LEAD WINDINGS CAN BE OPERATED.

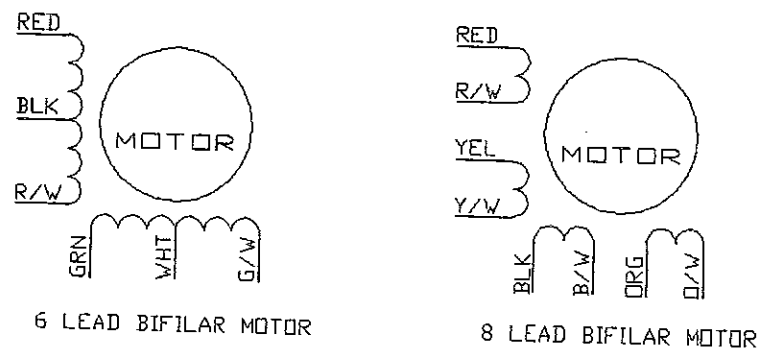

DIAGRAM 7.1

Motor Current Rating

The basic current output range is .9 to 4.0 Amps per phase, bifilar rating.

Inductance

The minimum motor inductance of .5mH bifilar is required on all models of drives for the power switching stage to be able to control currents.

Size

Recommended motor sizes for the P325 Series is size 17 to size 42 motors. (see Appendix A). Other controlling factors are the motor's current rating, inductance and winding type.

If a question remains about whether a particular motor can be operated, please contact the Controls Division for application assistance.

8 DRIVE CONFIGURATION AND CONNECTIONS

8.1 Drive Configuration

8.1.1 Introduction

To provide the user with the greatest amount of versatility, four adjustments can be made to configure the drive for the application. The first adjustment, selection of the low voltage tap on the transformer, sets the drive for the voltage rating of your motor. The second and third adjustments are dip switch settings which tell the driver the current rating of the motor and the optimum current profile for your motor. The fourth setting establishes the microstep resolution desired.

Depending on how you ordered, the drive may have already been set for a specific motor or to standard default conditions which require you to go through a setup process for your specific application and motor.

The setting will be found on a label affixed to the drive at the factory. Examine the label. If a motor is listed and corresponds to the selected motor, then continue with the microstep resolution switch settings, (Section 8.1.5). If the listed motor differs or if no label can be found, follow the procedures in this section to verify and adjust the settings, disconnect power before proceeding. After making any adjustments, be sure to note of them for future reference.

8.1.2 Low Voltage Adjustment

The P325 has the capability of running any hybrid (1.8 degree) step motor with ratings from 1 - 4.0 amps per phase. Two settings must be made to configure the driver to the power rating of the motor. The first is the motor voltage and the second is the motor current rating.

With the drive enclosure removed, a transformer will be located with four spade lugs protruding from one end numbered; 1, 2 and 3. To configure the drive to the motor being used, you must attach the "BLUE" wire to the proper low-voltage lug (see Figure 8.1.2 for location). Consult APPENDIX A, for the motor you intend to drive and its corresponding low-voltage lug.

If you intend to run a motor not listed in APPENDIX A, please consult the factory for appropriate instructions.

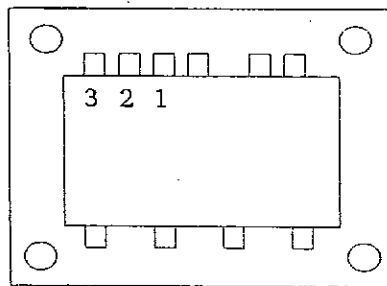

Figure 8.1.2

8.1.3 Current Switch Settings

If your drive and motor were purchased together as a package, then the current settings should have been previously made by your supplier. It is still advisable to verify that the settings are correct prior to applying power to the drive.

Before making connections to the drive, the current setting for the motor's rated current per phase should be determined and set at the 8 position DIP switch located on the logic board (see Diagram 8.1.3 for location).

Current Settings

Amps per Phase	Switch (NOTE 1),(NOTE 2) Block #2 <u>12345678</u>
1.6	10000
0.8	01000
0.4	00100
0.2	00010
0.1	00001

NOTE 1 - See DIAGRAM 8.1.3 for location of Switch Block #1.
A "0" indicates that the switch is "OFF" and a "1" indicates the switch is "ON".

NOTE 2 - The nominal current is 0.9 amps/phase with switches 1-5 on block #2 turned OFF. Drive output current is the sum of the switches 1-5 plus 0.9 amps/phase.

POT. ADJ. (VCO OPTION)

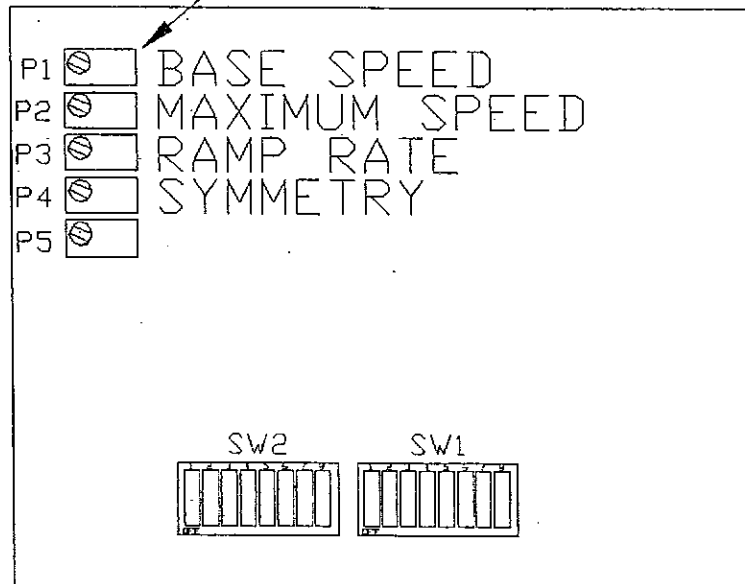

NOTE SW3 IS LOCATED ON THE RIGHT SIDE OF THE P325 SERIES DRIVE.

If not known the user should determine the current per phase rating of the motor to be used and whether or not the rating meets the drive requirements.

Once the motor part number and current rating is known, refer to Appendix A or B to determine the closest listed current setting. If the closest current is within 10% of the rated current, it will probably suffice for most applications. Current settings greater than 10% more than the rated value should not be used unless special cooling precautions are taken or intermittent operation allows for liberal use of the Low Power state. These precautions should preclude motor temperatures greater than the maximums specified by the manufacturer. By using a ball point pen or pointed object, duplicate the switch settings given in the Appendix at the DIP switch on the drive. DO NOT switch the settings with power applied to the motor.

8.1.4 Current Profile Settings

After selecting the proper low-voltage tap and current for the rating of the motor, you must select a current profile which is optimum for the motor. This is done by dip switch #2, see Figure 8.1.3 for location. Reference APPENDIX A for the values, and set the switches as indicated.

8.1.5 Microstep Resolution Switch Settings

The P325 Series drive allows the the user the versatility to select a microstep resolution that best matches his application requirements. For a standard 1.8^o step motor there are nine selectable resolutions that range from 200 to 25,600 steps per revolution. Refer to APPENDIX B and determine the resolution that best meets your needs and set the switches as indicated.

The user may wish to record the drive configuration settings in the table provided below before proceeding to the section on drive connections. The drive may be closed at this time as further internal adjustments are not required.

P325 Configuration Settings

Motor Model	_____	Date: _____
Current Setting	_____	
Voltage Tap	_____	
Step Resolution	_____	
	12345678	
Switch Block #1	_____	
Switch Block #2	_____	
Switch Block #3	_____	

Notes:

8.2 Drive Connections

8.2.1 Introduction

This section will list and explain all the connections to the P325 Series drives which includes motor, logic and power connections.

Notation and Conventions

All available logic inputs have two possible input states which will be referred to as "High" and "Low". When a logic terminal is open it is in a "High" state by default since it is clamped "High" internally with a pull-up resistor. Any notation which uses the "bar" convention will assume that the state indicated by the bar is activated by taking that logic terminal "Low" (ie. - CW/CCW denotes CCW direction of rotation when taken "Low").

Connector Type

Three plug type connectors allow the user to make the necessary connections via recessed screw terminals which control a clamping action on the bare wire of each input. It is recommended that connections be made prior to plugging into the drive.

- NOTE: 1.) Motor Connections are made on the 7 pin connector.
2.) Logic Connections are made on the 8 pin connector.
3.) Power Connections are made on the 3 pin connector.

8.2.2 Motor Connections

MOTOR CONNECTIONS (7 PIN CONNECTOR)

MOTOR LEAD TERMINALS (Terminal #'s 1-7)

The leads from the chosen motor will be connected at some or all of these terminals. Diagrams showing the possible connections for 6 or 8 lead motors.

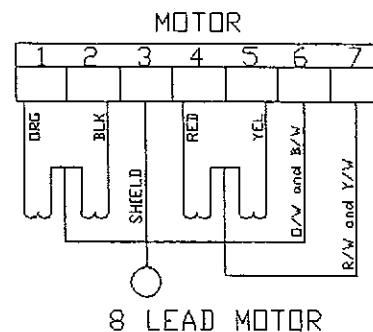
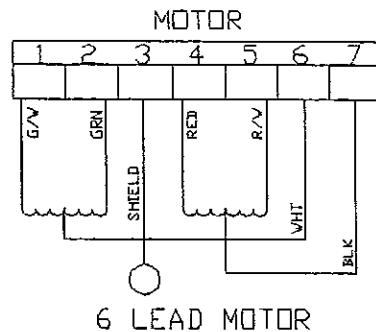

CAUTION: Do not supply power to the drive without having all of the motor leads firmly connected to their appropriate terminals.

8.2.3 Logic Connections

The logic inputs required by the P325 are made on the 8 pin connector and plugged into the drive section labeled "LOGIC". All Logic inputs can be optically isolated by providing a 5 VDC source.

Each of the logic inputs is clamped "High" internally with a pull-up resistor and requires the user's controller to pull them "Low" to return of the "OPTO IN" supply. Each of the user's control lines should be capable of sinking at least 15 ma. The optical isolation feature electrically isolates the motor and power stages of the drive in order to protect both circuits and eliminate electrical noise problems.

GROUND (Terminal 1)

This terminal is the reference ground for the +5V OUT supply. This reference ground should be only be connected to the ground of the users controller when the optical isolation feature is defeated.

STEP INPUT (Terminal 2)

The motor will be instructed to step on the rising edge of each incoming pulse up to a rate of 1 MHz. The minimum input pulse width is 1 micro seconds.

DIRECTION (Terminal 3) - "CW/ $\overline{\text{CCW}}$ "

A "High" or open connection on this terminal would cause a Clockwise (CW) rotation of the motor as viewed from the output shaft end. When taken "Low", the direction will be counterclockwise (CCW). The direction input may be switched while the motor is rotating, but may cause the motor to lose synchronism if operating above it's Start/Stop torque capability.

LOW POWER (Terminal 4) - "HI/ $\overline{\text{LOW POWER}}$ "

This input allows the user to reduce the power to the motor to one-fourth of the high current setting. The "High" or open state provides full current to the motor. When taken "Low", the current is reduced to 25% of it's full rated power. This may be used to maintain a holding current on the motor or to help reduce motor heating.

POWER ENABLE (Terminal 5) - "ENA/ $\overline{\text{NO POWER}}$ "

This input allows the user to cut off power to the motor on command. The "High" or open state allows normal stepping of the motor at it's rated current. When taken "Low", all power is cut to the motor for the duration of the "Low" state. Incoming step pulses are ignored when this line is held "Low". Normally this input is used to issue an emergency stop command to the motor.

NO CONNECTION (Terminal 6) - "NC"

This terminal is not connected internally.

OPTO INPUT (Terminal 7) - "OPTO IN"

The user must provide +5 VDC here to operate the optical isolation feature of the P325. The optical isolation feature will be defeated if the user chooses to use the on-board +5 VDC supplied by the P325 drive on logic terminal #8.

+5V OUT (Terminal 8)

This terminal can be jumpered to "OPTO IN" to defeat the optical isolation feature. This output should not be used to drive any external loads as damage to the drive may result.

8.2.4 Power Connections

Ensure that your power source is 115 VAC, 60 Hz.

A three prong power cord with a 3 pin plug type connector is provided with the package. Simply plug the connector into the mating socket on the drive and plug into the power source. When power is present, the green LED will be illuminated. Pin out list follows:

AC Input Black Wire (Line)Line
AC Input White Wire (Neutral)Neutral
AC Input Green Wire (Ground)Ground
LED indicating power onPower

9 INSTALLATION

The contents of this section will guide the user through the proper steps required to safely install and hook-up the P325 Series drivers. This section should be read in it's entirety for first-time installers and reviewed during the installation process.

9.1 Cooling

The base of the P325 is a heatsink which allows for heat dissipation produced by the internal components. During operation the heatsink will become warm to the touch and should not be a concern to the user. Additional air cooling devices are not required except where ambient temperatures are high or high current motors are used. Consult the factory if these conditions exist.

The most fundamental rule to follow concerning proper cooling of the drives is to keep the heatsink surface temperature less than 65°C. Since the drive is convection cooled, it is recommended that you allow a minimum of one inch on all sides for air flow. Operating in an enclosed area may require external cooling in order to keep the heatsink temperature less than 65°C (ie. - forced air fan). For a rule of thumb if you are not able to measure the heatsink temperature, the heat sink temperature is within limits if you can comfortably hold your finger on it more than 3 seconds.

9.2 Mounting

The P325 is a self-contained package requiring minimal concern for mounting methods and positions. A dimensional outline of the P325 is given in Figure 9.2. Flanges with mounting holes have been provided to mount or secure the P325. The recommended mounting position is vertical with the heatsink exposed to allow convection and heat removal from the drive. The user should refrain from mounting where the heatsink is unexposed or where easy access to the connectors or adjustments is not practical.

In general, the drive should be positioned close to the motor although step motors are fairly tolerant of long lead lengths. Should the drive need to be positioned more than 6 feet from the motor, consult the factory for the availability of motors with longer lead lengths.

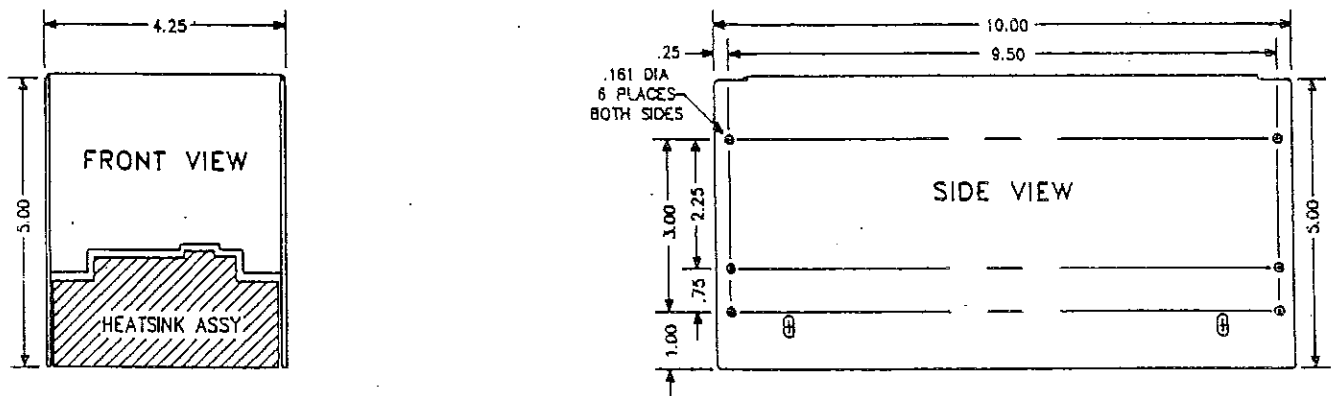

Figure 9.2

9.3 Drive Configuration

9.4 Drive Connections

Motor Connections

Motor connections are made on the 7 pin pluggable connector provided with the drive. If you purchased the drive with a motor, then the motor connections and current switch settings will already have been made. If not, then refer to Section 8 Appendix A and Appendix B for the proper drive settings.

Logic Input Connections

The minimum logic connection required to operate the P325 Series drive is the pulse input. All other inputs will default to their "High" states during operation. If other states are required then the ability to take them "Low" should be available. Refer to the terminal descriptions in Section 8.2.3 to determine the required inputs.

Logic input connections are made through use of an 8 pin pluggable connector. The connector may be pulled out by applying a force straight away from the drive. Connect each input by inserting 1/4 inch of stripped bare wire into the socket and tighten the pressure screw until the wire is firmly secured.

9.5 Applying Power

Once the drive is properly mounted and all of the required connections have been made, the drive may be powered up. Plug the 3 pin mating plug into the drive and then the power cord into 115 VAC source. Initial power should be applied with no pulses being fed to the drive. The motor will lock into position at it's rated static torque. Once the pulse input rate begins, the motor should begin to step in the set direction. At this point, if the motor does not have any torque or will not properly rotate, refer to Section 12 for possible remedies.

10 PERFORMANCE EXPECTATIONS

Step motors are quite unique in many aspects of their design, performance and control. Many attributes of a step motor can be attractive to the application designer; such as their simplicity, digital nature, and inherent open loop capability. Other attributes have to be overcome to allow a step motor to perform the best in an application; such as resonant instability and loss of torque as a function of speed. It turns out that a step motor's driving electronics play just as important a role in performance as the motor itself. Since a motor's inductance acts to inhibit current buildup and decay, the faster that current can be moved, the more that torque producing current will be pumped through the windings.

A bilevel drive, such as the P325 Series, is designed to minimize the current rise times by its bilevel voltage driving action. The user can expect to achieve relatively fast stepping rates with these drives running in an open loop capacity; in general, the lower the inductance of the driven motor (also, the higher the current rating), the faster the drive will be able to step the motor.

Since all step motors exhibit resonant instability at lower speeds, the user should try to minimize their effect by microstepping. The unstable areas of a full or half stepped motor are characterized by erratic motion and a severe loss of torque. A microstepped motor will exhibit less resonance than a full stepped motor.

Sample performance curves are provided in Appendix C for your reference.

11 P325 SPECIFICATIONS

General:

Drive Type 4 Phase, bi-level voltage, constant current
Stepping Modes Dip switch selectable microstep modes, 200,
400, 800, 1600, 3200, 6400, 12800, 25000,
25600

Power Requirements:

Input 100-122 VAC. 60Hz
Output Rating9 to 4 Amps per phase
Dip Switch Selectable

Physical:

Dimensions 4.25"W x 5.0"H x 10.0"L
Weight 5 lbs.

Temperature:

Storage -40° F to +185° F
(-40° C to +85° C)
Operating 150° F (65° C) maximum heatsink temperature

Logic Inputs:

Type Optical Isolated with a separate user
supplied + 5 VDC, 100 milliamp minimum
Level Logic '1' (HIGH) = 2.0 to 5.0 VDC
Logic '0' (LOW) = 0 to 0.5 VDC
Step Step on trailing edge of a square wave
signal. Requires 1 microseconds minimum
width at a maximum rate of 1 MHz. TTL
compatible.
Direction "CW/CCW"
Low Power "HI/LO POWER"
Reduces motor current to 25% of full power
Power Enable "ENABLE/NO POWER"
reduces current to motor to zero

Motor:

Motor Connections Connections for 6, or 8 lead hybrid motors

12 TROUBLESHOOTING

If a problem occurs the operator should immediately turn off and disconnect all power to the drive before attempting any troubleshooting or repair. Initial troubleshooting of the drive should be done with the load disconnected to isolate the drive from possible load related problems. The following list of symptoms, causes, and corrections may help to guide the user through a problem solving session.

MOTOR SHAFT FAILS TO TURN -

No power to drive - check if AC voltage is present by checking if the green LED indicator on the drive is illuminated.

Open motor windings - check that each motor winding phase has the appropriate resistance with no open coils.

No incoming pulse - check for proper level and width of pulse at Logic Pin #2 (Step).

No power logic - check to see that Logic Pin #5, (ENA/NO POWER) is "High" or open.

Low power logic - check to see that Logic Pin #4 (HI/LO POWER) is "High" or open.

Fixed load - check to see that driven load is not jammed or too large a load for the chosen motor size.

MOTOR MOTION IS ERRATIC -

Improper lead connections - confirm that the leads of the motor are connected with the proper sequence.

Winding continuity - check to see that each phase of the motor has the appropriate resistance with no shorts between windings or to the housing.

Incoming pulse integrity - confirm that the pulses being supplied to the driver are the proper level and width and that the rates are not too fast for the motor to maintain synchronism.

Resonant instability - confirm that the motor is not operating in a resonance range by adjusting the pulse rate.

Current profile adjustment - confirm that the dip switches are set for selected motor. If the problem of rough microstepping persists then the following procedure is recommended. Adjust the pulse rate to achieve a shaft speed of one revolution per second, next adjust the dc-offset potentiometers R4 and R18 to achieve smooth rotation of the motor shaft, (see location next page). The adjustment of the dc-offset potentiometers will fine tune the drive to the selected motor.

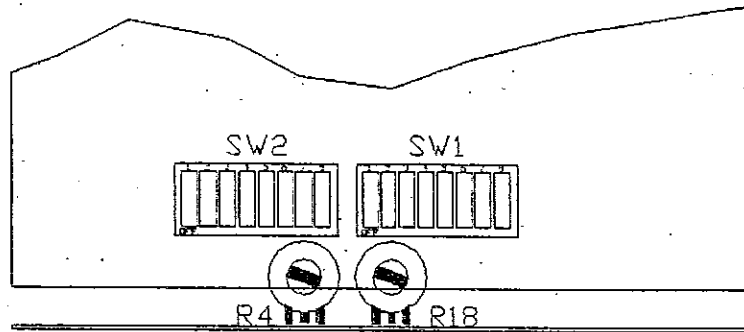

MOTOR RUNS VERY HOT -

Normal operating mode - it is normal for step motors, when run at their rated current, to be hot to the touch when operating. In general, if the motor case temperature is less than 85° C., there is no cause for concern.

Current set too high - check to see that the current is set at the appropriate level for the motor being operated.

MOTOR FAILS DURING ACCELERATION OR WHILE RUNNING -

Improper acceleration rate - check that the increasing rate of pulses feed to the drive is not too fast for the motor to maintain synchronism with the driven load.

Erratic loading - if the driven load dramatically changes while motor is driving, it could overcome the speed/torque capability of system - try to run the motor with the load disconnected.

No power logic - be sure that Logic Pin #5 (ENA/NO POWER) is "High".

If all of the above remedies are attempted and the problem still remains, you may have to return the drive for service.

For assistance contact -

Your local API representative.

Your local Distributor.

or
CONTROLS DIVISION
 4401 Genesee St.
 Buffalo, NY. 14225
 (716) 631-9800
 FAX: (716) 631-0152

To return a drive for service -

Please call the number above to receive a Return Material Authorization Number. You will be instructed at that time where to return the drive for the most expeditious service.

13 VELOCITY CONTROL OSCILLATOR OPTION (P325V)

13.1 Description

For applications requiring only the start/stop and direction control of the motor, the P325V is equipped with a pulse generator capable of 1 to 1,000,000 pulses per second with built-in acceleration and deceleration capability. In essence, the motor will start at a BASE SPEED when the STOP/RUN input is taken "Low". After a subsequent ACCEL input is taken "Low", the motor will accelerate to an MAXIMUM SPEED. The CLOCK OUT output is available for the user to monitor the number and frequency of pulses taken.

When the upper speed is reached, the output AT SPEED, terminal #10 becomes a logical "Low" signal available to the user. This signal can drive one low power TTL load with a maximum capacitance of 15 picofarads.

The motor will decelerate to the base speed with a logical "High" or open at the ACCEL input, and a subsequent "High" or open at the STOP/RUN input will bring the motor to a halt. The acceleration and deceleration rates, upper speed and base speeds are adjustable by the user thru potentiometers on the drive.

13.2 P325V Logic Connections

The logic inputs required by the P325V are made on the 12 pin connector and plugged into the drive section labeled "LOGIC". All Logic inputs can be optically isolated by providing a 5 VDC source.

Each of the logic inputs is clamped "High" internally with a pull-up resistor and requires the user's controller to pull them "Low" to "OPTO IN" supply return. Each of the user's control lines should be capable of sinking at least 16 ma. The optical isolation feature electrically isolates the motor and power stages of the drive in order to protect both circuits and eliminate electrical noise problems.

GROUND (Terminal 1)

This terminal is the reference ground for the +5V OUT supply on the drive. This reference ground should only be connected to the ground of the users controller when the optical isolation feature is defeated.

STEP INPUT (Terminal 2)

The user may wish to input step pulses to this input when the VCO Option is disabled. No connection is necessary when utilizing the VCO Option. The motor will be instructed to step on the rising edge of each incoming pulse up to a rate of 1 MHz. The minimum input pulse width is 1 micro seconds.

DIRECTION (Terminal 3) - "CW/CCW"

A "High" or open connection on this terminal would cause a Clockwise (CW) rotation of the motor as viewed from the output shaft end. When taken "Low", the direction will be counterclockwise (CCW). The direction input may be switched while the motor is rotating, but may cause the motor to lose synchronism if operating above it's Start/Stop torque capability.

LOW POWER (Terminal 4) - "HI/LO POWER"

This input allows the user to reduce the power to the motor to one-third of the high current setting. The "High" or open state provides full current to the motor. When taken "Low", the current is reduced to 33% of its full rated power. This may be used to maintain a holding current on the motor or to help reduce motor heating.

POWER ENABLE (Terminal 5) - "ENA/NO POWER"

This input allows the user to cut off power to the motor on command. The "High" or open state allows normal stepping of the motor at its rated current. When taken "Low", all power is cut to the motor for the duration of the "Low" state. Incoming step pulses are ignored when this line is held "Low". Normally this input is used to issue an emergency stop command to the motor.

RUN (Terminal 6) - "STOP/RUN"

A "High" or open connection on this terminal would cause the motor to stop. When taken "Low", the motor will begin to run at the BASE SPEED in the direction set by terminal 2. This input must be held "Low" for the duration of the desired motion.

OPTO INPUT (Terminal 7) - "OPTO IN"

The user must provide +5 VDC here to operate the optical isolation feature of the P325. The optical isolation feature will be defeated if the user chooses to use the on-board +5 VDC supplied by the P325 drive on logic terminal #8.

+5V OUT (Terminal 8)

This terminal can be jumpered to "OPTO IN" to defeat the optical isolation feature. This output should not be used to drive any external loads as damage to the drive may result.

CLOCK OUT (Terminal 9)

This output will allow the user to monitor the number and frequency of pulses generated by the VCO Logic Board during a commanded move. This output will go "Low" for each step taken.

AT SPEED (Terminal 10)

This output may be utilized by the user for indicating when the motor has reached MAXIMUM SPEED. This output remains "High" and goes "Low" whenever the motor is at MAXIMUM SPEED.

OUTPUT COMMON (Terminal 11)

This terminal provides reference ground for all optically isolated outputs. This reference ground should be connected to the return of the "OPTO IN" supply when the optical isolation is used or to the ground or the user's controller if the optical isolation is being defeated.

ACCELERATE (Terminal 12) "ACCEL"

This input will allow the user to control the transition, (acceleration and deceleration) between the BASE SPEED and the MAXIMUM SPEED on command. The "High" or open state causes the drive to decelerate the motor to the BASE SPEED. When taken "Low", the drive will accelerate the motor to the MAXIMUM SPEED. Note that the RUN input terminal 6 must be active or held "Low" during the operation of the ACCEL input control signal.

13.3 Adjustments

Determine the upper speed of your application and set switch block #1 as shown below, (only one switch 1, 2, 3 or 4 can be set to "ON", multiple settings will result in damage to the drive), be sure power is disconnected. The enclosure may be reinstalled at this time.

Selection of VCO Maximum Upper Speed

<u>Maximum Pulse Rate Pulses per Second</u>	<u>Switch (NOTE 1), (NOTE 2) Block #1 12345678</u>
125,000	1000
250,000	0100
500,000	0010
1,000,000	0001

NOTE 1 - See DIAGRAM 8.1.3 for location of Switch Block #1.
A "0" indicates that the switch is "OFF" and a "1" indicates the switch is "ON".

NOTE 2 - Switches #1, 2, 3 and 4 are set to "OFF" for user supplied pulse train.

TABLE #4

Adjustment of Potentiometers

Four potentiometers marked on logic end of the drive are set once for a given application. These potentiometers must be set in the following order. The BASE SPEED potentiometer should be set just below the error-free start/stop speed under load.

The MAXIMUM SPEED is set for the desired final speed of the motor by adjusting the potentiometer while monitoring the application or the CLOCK OUT terminal #9.

The RAMP RATE adjustment is for control over the combined times of acceleration and deceleration. The SYMMETRY potentiometer provides for control of the acceleration time versus the deceleration time within the established total time frame. Acceleration and deceleration are near linear speed/time relationships for most applications. In an application where frictional loads assists stopping but hinders starting, acceleration time is greater than deceleration time. The SYMMETRY adjustment should be made to provide less slope (more time) for acceleration than for deceleration. See FIGURE 13.3.1.

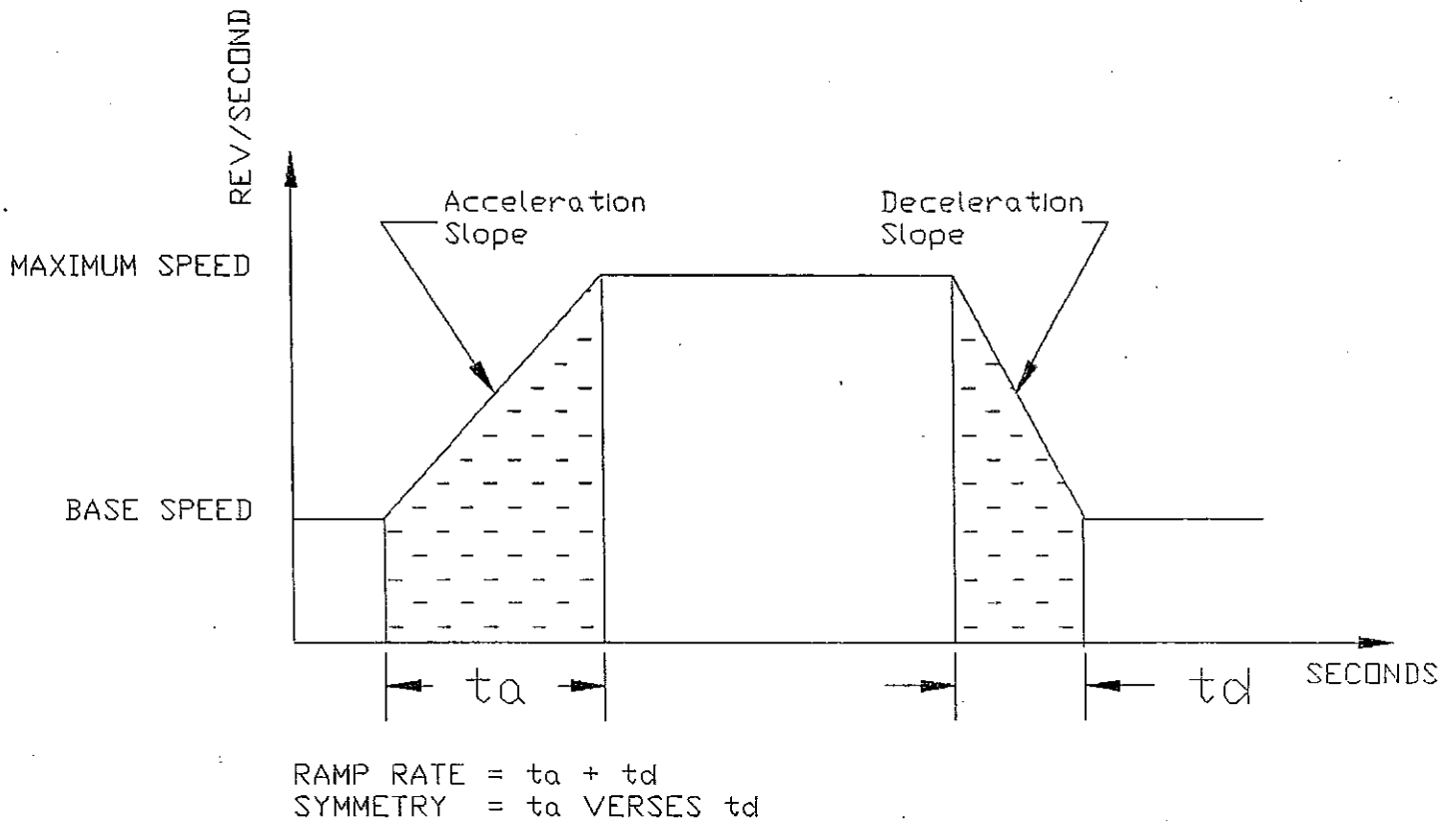

FIGURE #13.3

13.4 VGO Specifications

The P325V has the same general specifications as the standard P325 Series driver, see SECTION 11, with the additional specifications listed below.

Ramp rate: 50 to 1 control ratio
 5 second max. acceleration time
 100 msec min. acceleration time

TTL LOGIC INPUTS:

- * STOP/RUN - On a "High" signal the motor is stopped.
 - On a "Low" signal the motor runs at the BASE SPEED.
- * ACCEL - On a "High" signal the motor is decelerated.
 - On a "Low" signal the motor is accelerated.

TTL LOGIC OUTPUTS: The logic outputs can drive one low power TTL load with a maximum capacitance of 15 picofarads.

- * AT SPEED indicator - goes "Low" when at MAXIMUM SPEED
- * CLOCK OUT indicator - goes "Low" for each motor step

14 APPENDIX A API Motor Listing

P325 PACKAGES	STATIC TORQUE (Oz. In.)	WIDTH/ LENGTH (Inch.)	*Bifilar	VOLTAGE TAP	**DIP SWITCH #2 [12345678]	CONTROLS DIV. MOTOR PART NUMBER
			RATED CURRENT (Amps/ph)			
P325-A231A	***	2.3/2.0	1.0	3	00001	A231-02A
P325-M171	15	1.7/1.3	1.7	2	01000	M171-03
P325-M172	20	1.7/1.8	2.1	2	01100	M172-04
P325-M231	55	2.3/2.0	1.0	3	00001	M231-02
P325-M232	90	2.3/3.3	1.8	2	01001	M232-04
P325-M233	120	2.3/4.0	2.9	2	10100	M233-06
P325-M341	150	3.4/1.9	3.0	2	10101	M341-06
P325-M342	300	3.4/3.7	4.0	2	11111	M342-08
P325-M343	400	3.4/5.3	3.5	2	11010	M343-07
P325-M421	600	4.2/4.9	3.5	3	11010	M421-32
P325-M422	800	4.2/7.0	3.8	3	11101	M422-08

* - See Section 8 for an explanation of motor connections. Current switch settings for all the P325 series drives.

** - A "0" indicates that the switch is "OFF" and a "1" indicates the switch is "ON". (See APPENDIX B for microstep resolution switch settings.

*** - Linear Acctuator Model. Force is 100 lbs. for the packaged model that includes a .050 inch lead screw (20 pitch). Other lead screw pitches are available upon request.

Motors supplied with these packages come with the following:

-> Size 17 motors are 12 inch leads in an 8 lead configuration with a single ended shaft.

Size 23 and 34 motors may be supplied with the following features:

- > Dual-shafted with a flat on the front shaft extension for positive load coupling.
- > Designed to accept a 1000 line Dual Channel Incremental Optical Encoder feature with Z channel home reference.
- > With 8 leads in twisted pairs in a six (6) foot shielded cable.

Size 42 motors may be supplied with the following features:

- > Dual-shafted with a flat/woodruff key on the front shaft extension for positive load coupling.
- > Designed to accept a 1000 line Dual Channel Incremental Optical Encoder feature with Z channel home reference.
- > With 8 leads in twisted pairs in a six (6) foot shielded cable.

15 APPENDIX B Dip Switch Settings

Current Settings

Amps per Phase	Switch (NOTE 1),(NOTE 2) Block #2 12345678
1.6	10000
0.8	01000
0.4	00100
0.2	00010
0.1	00001

NOTE 1 - See DIAGRAM 8.1.3 for location of Switch Block #2.
A "0" indicates that the switch is "OFF" and a "1" indicates the switch is "ON".

NOTE 2 - The nominal current is 0.9 amps/phase with switches 1 - 5 on block #2 turned OFF. Drive output current is the sum of switches 1 - 5 plus 0.9 amps/phase.

Microstep Resolution

Steps per Revolution	Switch (NOTE 1) Block #1 12345678	Switch (NOTE 2) Block #2 12345678	Switch (NOTE 3) Block #3 12345678
200	1110	000	11111111
400	1110	001	01111111
800	1110	010	00111111
1600	1110	011	00011111
3200	1110	100	00001111
6400	1110	101	00000111
12800	1110	110	00000011
25000	(NOTE 4)	111	11000001
25600	1110	111	00000001

NOTE 1 - See DIAGRAM 8.1.3 for location of Switch Block #1.
A "0" indicates that the switch is "OFF" and a "1" indicates the switch is "ON". Switches 1 - 4 are only utilized with the velocity control oscillator option (P325V).

NOTE 2 - See DIAGRAM 8.1.3 for location of Switch Block #2.
A "0" indicates that the switch is "OFF" and a "1" indicates the switch is "ON".

NOTE 3 - See DIAGRAM 8.1.3 for location of Switch Block #3.
A "0" indicates that the switch is "OFF" and a "1" indicates the switch is "ON".

NOTE 4 - Selectable current profile settings are available for specific frame size motors when utilizing a microstep resolution of 25,000 steps per revolution.

Profile Settings (25,000 Steps per Revolution Only)

Step Motor Frame Size	Switch (NOTE 1)	Switch (NOTE 2)	Switch (NOTE 3)
	Block #1 12345678	Block #2 12345678	Block #3 12345678
M171-03	0100	00001111	11000001
M172-04	0100	00001111	11000001
M231-02	0100	00001111	11000001
M232-04	1000	01001111	11000001
M233-06	0010	10100111	11000001
M341-06	0001	10101111	11000001
M342-08	0101	11111111	11000001
M343-07	1001	11010111	11000001
M421-32	1001	11010111	11000001
M422-08	1001	11101111	11000001

NOTE 1 - See DIAGRAM 8.1.3 for location of Switch Block #1.
A "0" indicates that the switch is "OFF" and a "1" indicates the switch is "ON".

NOTE 2 - See DIAGRAM 8.1.3 for location of Switch Block #2.
A "0" indicates that the switch is "OFF" and a "1" indicates the switch is "ON".

NOTE 3 - See DIAGRAM 8.1.3 for location of Switch Block #3.
A "0" indicates that the switch is "OFF" and a "1" indicates the switch is "ON".

CLOSED 'ON' OPEN 'OFF'

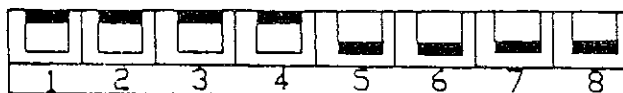

SWITCH SETTINGS

16 APPENDIX C Performance Curves

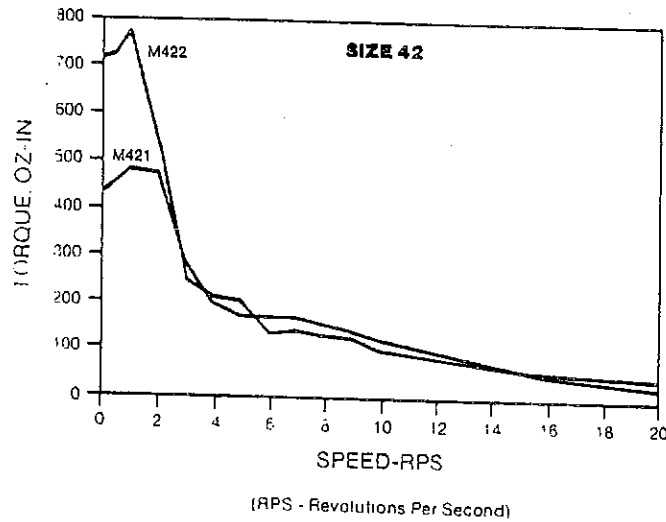
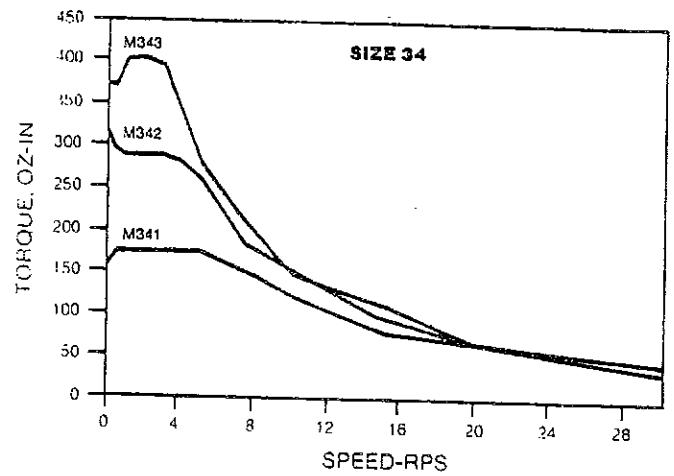
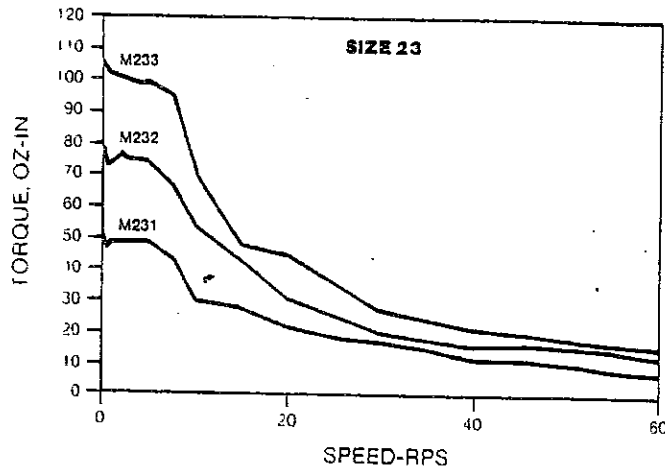

Pullout curves generated utilizing 115VAC input, 3200 steps per revolution, and the SAC-560 Smart Axis Controller to provide ramping routines and step pulses.

MOTOR SELECTIONS/DIMENSIONS

Motor	Static Torque (Oz.-In.)	Width	Length
P325-A231	**	2.23" (57mm)	2.00" (51mm)
P325-M171	15	1.70" (42mm)	1.34" (34mm)
P325-M172	20	1.70" (42mm)	1.54" (39mm)
P325-M173	25	1.70" (42mm)	1.84" (47mm)
P325-M231	55	2.23" (57mm)	2.00" (51mm)
P325-M232	70	2.23" (57mm)	3.25" (83mm)
P325-M233	125	2.23" (57mm)	4.00" (102mm)
P325-M341	150	3.35" (85mm)	2.45" (62mm)
P325-M342	300	3.35" (85mm)	3.70" (93mm)
P325-M343	400	3.35" (85mm)	5.31" (135mm)
P325-M421	500	4.20" (106mm)	4.74" (120mm)
P325-M422	800	4.20" (106mm)	7.00" (178mm)

** - Linear Actuator model. Force is 40-100 lbs.

APPENDIX F Optional 25 pin D Logic Connector (P325-DO-DB25)

1.(+)STEP and 14.(-)STEP: These inputs are optically isolated and driven by producing a positive pulse to the (+)STEP with respect to the (-)STEP. These inputs may also be differentially driven. The step pulse must have a minimum of 200 nanosecond-pulse and a 40% - 60% duty cycle (2 MHz max pulse rate).

2.(+)DIRECTION and 15.(-)DIRECTION: These inputs are optically isolated and driven by producing a positive pulse to the (+)DIRECTION with respect to the (-)DIRECTION. These inputs may also be differentially driven. The direction input must be stable for at least 2 ms before the drive receives the first pulse.

9.FAULT COLL. and 21.FAULT EMIT.: These fault outputs work in conjunction to produce a fault signal if a fault condition arises. The output transistor will conduct when the drive is functioning properly. The transistor will not conduct when there is a fault condition. The different fault conditions are OVER CURRENT, OVER TEMPERATURE, or UNDER VOLTAGE

11.(+)RESET and 23.(-)RESET: These inputs are optically isolated and driven by producing a positive pulse to the (+) RESET with respect to the (-) RESET. This input allows you to reset the motor phase currents to the power up position. It must be active for 100 ms to reset and must be inactive for 100 ms before the first step pulse is received.

16.(+)SHUTDOWN and 17.(-)SHUTDOWN: These inputs are optically isolated and driven by producing a positive pulse to the (+) SHUTDOWN with respect to the (-) SHUTDOWN. This input can only be enabled when the motor is not moving. It must be active for 100 ms to shutdown and must be inactive for 100 ms before the first step pulse is received.

18.(-)LOW PWR. and 19.(+)LOW PWR.: These inputs are optically isolated and driven by producing a positive pulse to the (+) LOW PWR. with respect to the (-) LOW PWR.. This input allows you to take the motor to low power to reduce heat. It must be active for 100 ms to go into low power and must be inactive for 100 ms before the first step pulse is received.



AMERICAN PRECISION INDUSTRIES
CONTROLS DIVISION

4401 Genesee Street
Buffalo, New York 14225
716-631-9800
FAX 716-631-0152



Artisan Technology Group is your source for quality new and certified-used/pre-owned equipment

- FAST SHIPPING AND DELIVERY
- TENS OF THOUSANDS OF IN-STOCK ITEMS
- EQUIPMENT DEMOS
- HUNDREDS OF MANUFACTURERS SUPPORTED
- LEASING/MONTHLY RENTALS
- ITAR CERTIFIED SECURE ASSET SOLUTIONS

SERVICE CENTER REPAIRS

Experienced engineers and technicians on staff at our full-service, in-house repair center

*InstraView*SM REMOTE INSPECTION

Remotely inspect equipment before purchasing with our interactive website at www.instraview.com ↗

WE BUY USED EQUIPMENT

Sell your excess, underutilized, and idle used equipment. We also offer credit for buy-backs and trade-ins. www.artisanng.com/WeBuyEquipment ↗

LOOKING FOR MORE INFORMATION?

Visit us on the web at www.artisanng.com ↗ for more information on price quotations, drivers, technical specifications, manuals, and documentation

Contact us: (888) 88-SOURCE | sales@artisanng.com | www.artisanng.com