



Artisan Technology Group is your source for quality new and certified-used/pre-owned equipment

- FAST SHIPPING AND DELIVERY
- TENS OF THOUSANDS OF IN-STOCK ITEMS
- EQUIPMENT DEMOS
- HUNDREDS OF MANUFACTURERS SUPPORTED
- LEASING/MONTHLY RENTALS
- ITAR CERTIFIED SECURE ASSET SOLUTIONS

SERVICE CENTER REPAIRS

Experienced engineers and technicians on staff at our full-service, in-house repair center

*InstraView*SM REMOTE INSPECTION

Remotely inspect equipment before purchasing with our interactive website at www.instraview.com ↗

WE BUY USED EQUIPMENT

Sell your excess, underutilized, and idle used equipment. We also offer credit for buy-backs and trade-ins. www.artisanng.com/WeBuyEquipment ↗

LOOKING FOR MORE INFORMATION?

Visit us on the web at www.artisanng.com ↗ for more information on price quotations, drivers, technical specifications, manuals, and documentation

Contact us: (888) 88-SOURCE | sales@artisanng.com | www.artisanng.com

Last Revised: 2014-11-06 07:14:13.0

2.53 GHz Dual-Core Embedded Controller for PXI Express

NI PXIe-8108



- Intel Core 2 Duo T9400 processor (2.53 GHz dual core)
- Up to 1 GB/s system and up to 250 MB/s slot bandwidth
- 1 GB (1 x 1 GB DIMM) dual-channel 800 MHz DDR2 RAM standard, 4 GB (1 x 4 GB DIMM) maximum
- 80 GB integrated hard-drive standard
- 10/100/1000BASE-TX Ethernet port and four Hi-Speed USB ports
- Other peripherals (ExpressCard/34 slot, DVI-I video connector, IEEE 1284 ECP/EPP parallel port, GPIB (IEEE 488) controller, and RS232 serial port)
- Software - OS and drivers already installed and hard-drive-based recovery image
- Complete PXI system configuration at ni.com/pxiadvisor

Overview

The NI PXIe-8108 is a high-performance Intel Core 2 Duo T9400-based embedded controller for use in PXI and CompactPCI systems. With its 2.53 GHz dual-core processor and dual-channel 800 MHz DDR2 memory, the NI PXIe-8108 is ideal for applications requiring intensive analysis or system development. An NI PXIe-8108 embedded controller in a PXI Express chassis offers a compact, high-performance PC platform for modular instrumentation and data acquisition applications.

[Back to Top](#)

Requirements and Compatibility

OS Information

- Windows 7 32-bit
- Windows 7 64-bit
- Windows Vista
- Windows XP

[Back to Top](#)

Application and Technology

NI PXIe-8108 Features

CPU	Intel Core 2 Duo T9400 processor (2.53 GHz dual core)
L2 cache	6 MB shared
Dual-channel 800 MHz DDR2 RAM, standard	1 GB (1 x 1 GB)
Dual-channel 800 MHz DDR2 RAM, maximum	4 GB (1 x 4 GB)
Hard drive (standard option), minimum	80 GB SATA (5400 rpm)
Hard drive (extended temperature and 24/7 option), minimum	80 GB SATA (5400 rpm)
10/100/1000BASE-TX (Gigabit) Ethernet ports	1

Hi-Speed USB ports	4
GPIB (IEEE 488) controller	
Serial port (RS232)	
Parallel port	
ExpressCard/34 slot	
Watchdog/trigger SMB	
Installed OS ¹	Windows 7 Professional, Windows Vista Business, Windows XP Professional for Embedded Systems ²

¹Contact National Instruments or visit ni.com/pxiadvisor for information on other available operating systems.

²Due to the [Microsoft support life cycle](#) for Windows XP, National Instruments will be unable to provide PXI embedded controllers with Windows XP preinstalled after 2015. View the [Microsoft support life cycle](#) for full details about Windows XP end of life for OEM partners.

Table 1. NI PXIe-8108 Features

Dual-Core Processor

The NI PXIe-8108 includes the dual-core Intel Core 2 Duo T9400 processor. Dual-core processors contain two cores, or computing engines, in one physical package. They can simultaneously execute two computing tasks, which is advantageous in multitasking environments like Windows Vista or Windows XP, where multiple applications run simultaneously. Two applications, such as NI LabVIEW and Microsoft Excel, can each execute on a separate core at the same time, which improves overall system performance. Multithreaded applications, such as LabVIEW, take full advantage of dual-core processors because they automatically separate their tasks into independent threads. A dual-core processor can simultaneously execute two of these threads. Figure 1 compares the SYSmark 2007 overall performance of the NI PXIe-8108 controller with other PXI embedded controllers.

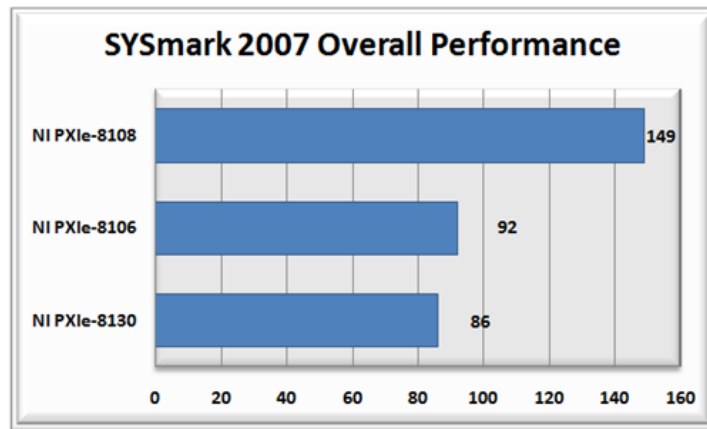

Figure 1. Embedded Controller Benchmarks

Hardware

With state-of-the-art packaging, the NI PXIe-8108 integrates the Intel Core 2 Duo T9400 processor and all standard and extended PC I/O ports into a single unit. By integrating many I/O ports on the controller, all active slots in the chassis remain available for measurement and control modules. This rugged one-piece controller design minimizes integration issues and eliminates the need for complex cabling to daughterboards. The NI PXIe-8108 block diagram is shown in Figure 2.

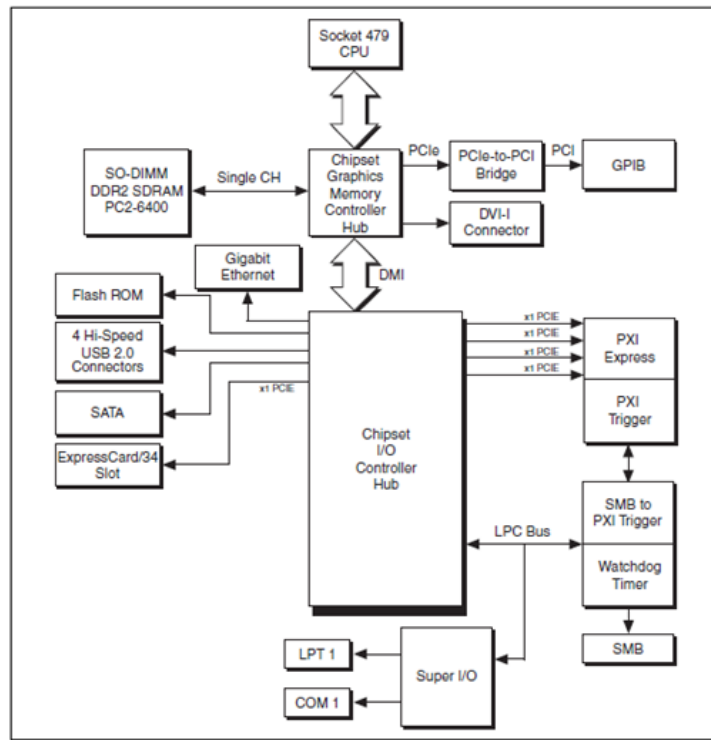

Figure 2. NI PXIe-8108 Block Diagram

Peripheral I/O

This module includes high-performance peripheral I/O such as 10/100/1000BASE-TX (Gigabit) Ethernet and four Hi-Speed USB ports for connection to a keyboard, a mouse, a CD-ROM/DVD-ROM drive for software installation, or other standard PC peripherals such as speakers, printers, or memory sticks. Use the IEEE 1284 ECP/EPP parallel port to connect to a wide variety of devices, including tape backup drives, printers, and scanners. An RS232 port is available for connecting to serial devices. Additionally, the NI PXIe-8108 controller includes an integrated GPIB (IEEE 488) controller, which provides control of external instrumentation, saving additional cost and a slot.

ExpressCard

This controller features an ExpressCard/34 slot. ExpressCard uses the PCI Express and Hi-Speed USB serial interfaces to provide up to 2.5 Gbit/s of bidirectional throughput. Use the ExpressCard/34 slot to add a second Gigabit Ethernet port to your system or additional peripheral I/O such as external hard drives, RAID arrays, 802.11 wireless LAN, IEEE 1394, Bluetooth, or various memory adapters.

Video

The NI PXIe-8108 includes a Mobile Intel GM45 Express Chipset (Graphics and Memory Controller Hub) that has an integrated graphics processing unit. It delivers intense, realistic 3D graphics with sharp images, fast rendering, smooth motion, and high detail, without the need for an additional video card or peripheral. This unique architecture provides balanced memory usage between graphics and the system for optimal performance. Additionally, the NI PXIe-8108 features a DVI-I video connector, compatible with digital (DVI) and analog (VGA) monitors. A DVI-I to VGA adapter is included with the controller for use with VGA monitors.

Dual Monitor Support

The DVI-I video port on the NI PXIe-8108 is capable of supporting simultaneous DVI and VGA output. With this built-in capability, you can connect a digital and an analog monitor or two analog monitors to your PXI system at the same time with independent displays. This negates the need for a separate PXI or CompactPCI video module to connect two monitors to your PXI system. A DVI-I (male) to DVI-D (female) and VGA (female) splitter is required for connecting the two monitors.

Memory

This controller uses dual-channel 800 MHz DDR2 SDRAM, which makes it ideal for data-intensive applications requiring significant analysis. It has a single SO-DIMM socket for the DDR2 SDRAM. 1 GB (1 x 1 GB DIMM) of RAM is standard with upgrade options to 4 GB.

Memory Options	Configuration	Part Number
Standard - 1 GB	1 x 1 GB DIMM	Included
2 GB	1 x 2 GB DIMM	780446-2048
Recommended - 4 GB	1 x 4 GB DIMM	780446-4096

Table 2. Memory Upgrade Options

Extended Temperature and 24/7 Operation Option

The NI PXIe-8108 is available in two versions to address different environmental and usage conditions. The primary difference is that the version for extended temperature and 24/7 operation uses a different hard drive, designed for both reliability in low- and high-temperature extremes and 24/7 operation. The standard version of the controllers has an operating temperature of 5 to 50 °C and a storage temperature of -40 to 65 °C. The extended temperature and 24/7 operation version has an operating temperature of 0 to 55 °C and a storage temperature of -40 to 70 °C.

You can also use the extended temperature and 24/7 operation version for applications that require continuous operation for up to 24 hours/day, seven days/week because the hard drive is rated for 24/7 operation. The hard drive in the standard version of the controllers is designed to be powered on for eight hours/day, five days/week. Additionally, 24/7 operation applications may subject the hard drive to a high duty cycle (the percentage of the maximum sustained throughput of the hard drive). The hard drive in the standard version of the controllers is designed for a 20 percent duty cycle. The hard drive in the extended temperature and 24/7 operation version has a capacity of 80 GB (minimum). See specifications for further details.

Hard-Drive-Based Recovery Image

The NI PXIe-8108 embedded controller is shipped with a factory image of the software installation stored on a separate partition of the hard drive. In the case of software

corruption, you can invoke a recovery tool during the controller's boot-up process that can use this backup image to restore the controller to its shipping software configuration. You also can use this recovery tool to create custom images that you can store on external mass storage devices such as a USB memory stick, USB hard drives, and USB CD/DVD drives. With this ability, you can create custom backup images that you can use to either recover an NI PXIe-8108 controller or replicate the installation on other NI PXIe-8108 controllers. For more information on this tool, refer to [KnowledgeBase ZK020K](#).

USB Peripherals

National Instruments offers a USB-to-dual-PS/2 keyboard/mouse adapter cable to connect a legacy PS/2 keyboard and mouse to a single USB port on your embedded controller. Additionally, NI offers external USB CD-ROM/DVD-ROM and USB floppy drives for use with your embedded controller. Connect these drives to your embedded controller for easy software installation and upgrades. Both are completely powered through the USB ports, so no external power connections are required. Additional USB peripherals, such as USB speakers to add audio or USB memory sticks to add easily removable memory, are widely available from PC peripheral manufacturers.

Additional Peripheral I/O

National Instruments offers numerous plug-in modules to add more peripheral I/O to your PXI system. With the wide variety of peripheral I/O modules available, you can choose modules that add communication with serial, IEEE 1394, and SCSI, in addition to numerous others. You also can obtain modules for controlling other PXI or VXI/VME systems. Visit [ni.com/pxiadvisor](#) to configure a system with additional peripheral I/O modules.

Software

The NI PXIe-8108 comes with the following minimum set of software already installed:

- Microsoft Windows OS (contact NI or visit [ni.com/pxiadvisor](#) for a list of available Microsoft operating systems and for localized versions)
- Hard-drive-based recovery image
- NI-VISA and NI-488.2 drivers
- Drivers for all built-in I/O ports

With NI system assurance programs added to a PXI system order, your embedded controller is shipped already configured with all software and drivers applicable for your system. For example, assume you order a PXI system that includes LabVIEW and NI TestStand software, as well as data acquisition modules, a digitizer, an arbitrary waveform generator, and a digital multimeter (DMM). With NI system assurance programs, NI not only assembles and tests your system but also fully configures the embedded controller with the appropriate NI-DAQmx, NI-SCOPE, NI-FGEN, and NI-DMM drivers, as well as LabVIEW and NI TestStand.

Additionally, your embedded controller is configured with a customized hard-drive-based recovery image, so you can restore your controller to the as-shipped configuration at any time. This combination of software configuration and recovery tools provides both a productive and reliable development experience with your PXI system out of the box. To configure a complete PXI system with NI system assurance programs, contact National Instruments or visit [ni.com/pxiadvisor](#).

[Back to Top](#)

Ordering Information

For a complete list of accessories, visit the product page on [ni.com](#).

Products	Part Number	Recommended Accessories	Part Number
Hard-Drive Spare/Replacement and Upgrades			
250 GB 2.5 in MLC SATA Solid State Hard Drive Upgrade	781945-01	No accessories required.	
60 GB (or Greater) 2.5 in SATA Blank HDD Spare/Replacement	779175-03	No accessories required.	
80 GB (or Greater) 2.5 in SATA Ext. Temp, 24/7 Hard Drive Upgrade	779175-07	No accessories required.	
500 GB 2.5 in SATA Hard Drive Upgrade	781946-01	No accessories required.	
32 GB 2.5 in SATA Solid State Hard Drive Upgrade	779175-08	No accessories required.	
NI PXIe-8108 Products			
NI PXIe-8108 Windows Vista Extended Temp	781034-02	No accessories required.	
NI PXIe-8108 Windows 7 32-bit Extended Temp	781034-04	No accessories required.	
NI PXIe-8108 Windows XP Extended Temp	781034-01	No accessories required.	
NI PXIe-8108 Windows Vista	781033-02	No accessories required.	
NI PXIe-8108 Windows 7 32-bit	781033-04	No accessories required.	
NI PXIe-8108 Windows XP	781033-01	No accessories required.	
Other Accessories			
NI MKD-1117 Rackmount 1U LCD Monitor, Keyboard, Mouse Drawer	779872-01	No accessories required.	
FPT-1015 15in. Flat Panel Touch Screen with VGA Interface and USB	779560-01	No accessories required.	
IEEE 1284 Parallel Port Cable Adapter, 6 in.	777169-01	No accessories required.	
X13 GPIB Cable, MicroD25 to Shielded cable/Standard connector, 2M	183285-02	No accessories required.	
ExpressCard Strain Relief Accessory for PXI Embedded Controllers	192524-01	No accessories required.	
Expresscard to Gigabit Ethernet Adapter (Windows Only)	781150-01	No accessories required.	
DVI-I (male) to DVI-D (female) & VGA (female) Splitter	780868-01	No accessories required.	
USB English Keyboard and Optical USB Mouse	779660-01	No accessories required.	
USB to Dual PS2 Keyboard/Mouse Adapter Cable	778713-02	No accessories required.	
External USB CD/DVD-ROM for Use with PXI & VXI Emb Controllers	778492-01	No accessories required.	
External USB Floppy Drive, for PXI & VXI Embedded Controllers	778492-02	No accessories required.	
FPM-1017 17in. Flat Panel Monitor with VGA Input for PC's	779559-01	No accessories required.	

Support and Services

System Assurance Programs

NI system assurance programs are designed to make it even easier for you to own an NI system. These programs include configuration and deployment services for your NI PXI, CompactRIO, or Compact FieldPoint system. The NI Basic System Assurance Program provides a simple integration test and ensures that your system is delivered completely assembled in one box. When you configure your system with the NI Standard System Assurance Program, you can select from available NI system driver sets and application development environments to create customized, reorderable software configurations. Your system arrives fully assembled and tested in one box with your software preinstalled. When you order your system with the standard program, you also receive system-specific documentation including a bill of materials, an integration test report, a recommended maintenance plan, and frequently asked question documents. Finally, the standard program reduces the total cost of owning an NI system by providing three years of warranty coverage and calibration service. Use the online product advisors at ni.com/advisor to find a system assurance program to meet your needs.

Technical Support

Get answers to your technical questions using the following National Instruments resources.

- **Support** - Visit ni.com/support to access the NI KnowledgeBase, example programs, and tutorials or to contact our applications engineers who are located in NI sales offices around the world and speak the local language.
- **Discussion Forums** - Visit forums.ni.com for a diverse set of discussion boards on topics you care about.
- **Online Community** - Visit community.ni.com to find, contribute, or collaborate on customer-contributed technical content with users like you.

Repair

While you may never need your hardware repaired, NI understands that unexpected events may lead to necessary repairs. NI offers repair services performed by highly trained technicians who quickly return your device with the guarantee that it will perform to factory specifications. For more information, visit ni.com/repair.

Training and Certifications

The NI training and certification program delivers the fastest, most certain route to increased proficiency and productivity using NI software and hardware. Training builds the skills to more efficiently develop robust, maintainable applications, while certification validates your knowledge and ability.

- **Classroom training in cities worldwide** - the most comprehensive hands-on training taught by engineers.
- **On-site training at your facility** - an excellent option to train multiple employees at the same time.
- **Online instructor-led training** - lower-cost, remote training if classroom or on-site courses are not possible.
- **Course kits** - lowest-cost, self-paced training that you can use as reference guides.
- **Training memberships** and training credits - to buy now and schedule training later.

Visit ni.com/training for more information.

Extended Warranty

NI offers options for extending the standard product warranty to meet the life-cycle requirements of your project. In addition, because NI understands that your requirements may change, the extended warranty is flexible in length and easily renewed. For more information, visit ni.com/warranty.

OEM

NI offers design-in consulting and product integration assistance if you need NI products for OEM applications. For information about special pricing and services for OEM customers, visit ni.com/oem.

Alliance

Our Professional Services Team is comprised of NI applications engineers, NI Consulting Services, and a worldwide National Instruments Alliance Partner program of more than 700 independent consultants and integrators. Services range from start-up assistance to turnkey system integration. Visit ni.com/alliance.

Detailed Specifications

This topic lists the electrical, mechanical, and environmental specifications of the NI PXIe-8108 embedded controller.

Features

NI PXIe-8108	
CPU	Intel® Core™ 2 Duo processor T9400 (2.53 GHz dual core processor), 1066 MHz FSB
On-die L2 cache	6 MB
Single-Channel DDR2 RAM, PC2 6400	1 GB Standard, 4 GB Maximum
Hard Drive	80 GB Serial ATA, minimum ¹ ²
Ethernet	10/100/1000 BaseTX
PXI Express 4 Link Configuration	x1, x1, x1, x1
PXI Express 2 Link Configuration	x1, x1

NI PXIe-8108	
GPIO (IEEE 488 Controller)	Yes
Serial Ports (RS-232)	Yes (1)
Parallel Port	Yes (1)
Hi-Speed USB (2.0) Ports	Yes (4)
ExpressCard/34 Slot	Yes
PS/2 Keyboard/Mouse Connector	No
PXI Trigger Bus Input/Output	Yes
Installed Operating System	Windows Vista Business, Windows Vista Business downgraded to Windows XP Professional

Electrical

Voltage (V)	Current (Amps)	
	Typical	Maximum
+3.3 V	2.25 A	3 A
+5 V	1.25 A	1.8 A
+12 V	2 A	2.8 A
-12 V	0 A	0 A
+5 V Aux	.330 A	.400 A



Note Does not include any attached USB devices or ExpressCard.

Physical

Board dimensions	Four-wide 3U PXI Express module
Slot requirements	One system slot plus three controller expansion slots
Compatibility	Fully compatible with <i>PXI Express Specification 1.0</i>
Weight	0.983 Kg (2.17 lb) typical

Environment

Maximum altitude	2,000 m (800 mbar) (at 25 °C ambient temperature)
Pollution Degree	2
Indoor use only.	



Caution Clean the NI PXIe-8108 with a soft nonmetallic brush. Make sure that the device is completely dry and free from contaminants before returning it to service.

Operating Environment

NI PXIe-8108	
Ambient temperature range	5 to 50 °C (Tested in accordance with IEC-60068-2-1 and IEC-60068-2-2. Meets MIL-PRF-28800F Class 3 high temperature limit.)
NI PXIe-8108 Extended Temperature Option	
Ambient temperature range	0 to 55 °C (Tested in accordance with IEC-60068-2-1 and IEC-60068-2-2. Meets MIL-PRF-28800F Class 3 low temperature limit and MIL-PRF-28800F Class 2 high temperature limit.)
Relative humidity range	10% to 90%, noncondensing (Tested in accordance with IEC-60068-2-56.)



Caution The operating temperature must not be exceeded, even when used in a chassis with a higher temperature range.

Storage Environment

NI PXIe-8108	
Ambient temperature range	-40 to 65 °C (Tested in accordance with IEC-60068-2-1 and IEC-60068-2-2. Meets MIL-PRF-28800F Class 3 low temperature limit.)
NI PXIe-8108 Extended Temperature Option	
Ambient temperature range	-40 to 71 °C (Tested in accordance with IEC-60068-2-1 and IEC-60068-2-2. Meets MIL-PRF-28800F Class 3 limits.)

Relative humidity range	5% to 95%, noncondensing (Tested in accordance with IEC-60068-2-56.)
Shock and Vibration	
Operating Shock	30 g peak, half-sine, 11 ms pulse (Tested in accordance with IEC-60068-2-27. Meets MIL-PRF-28800F Class 2 limits.)
Random Vibration	
Operating	5 to 500 Hz, 0.3 g _{rms} (with solid-state hard drive)
Nonoperating	5 to 500 Hz, 2.4 g _{rms} (Tested in accordance with IEC-60068-2-64. Nonoperating test profile exceeds the requirements of MIL-PRF-28800F, Class 3.)

 **Note** Specifications are subject to change without notice.

Safety Standards

This product is designed to meet the requirements of the following standards of safety for electrical equipment for measurement, control, and laboratory use:

- IEC 61010-1, EN 61010-1
- UL 61010-1, CSA 61010-1

 **Note** For UL and other safety certifications, refer to the product label or the *Online Product Certification* section.

Electromagnetic Compatibility

This product meets the requirements of the following EMC standards for electrical equipment for measurement, control, and laboratory use:

- EN 61326 (IEC 61326): Class A emissions; Basic immunity
- EN 55011 (CISPR 11): Group 1, Class A emissions
- AS/NZS CISPR 11: Group 1, Class A emissions
- FCC 47 CFR Part 15B: Class A emissions
- ICES-001: Class A emissions

 **Note** For the standards applied to assess the EMC of this product, refer to the *Online Product Certification* section.

 **Note** For EMC compliance, operate this device with shielded cables.

CE Compliance

This product meets the essential requirements of applicable European Directives, as amended for CE marking, as follows:

- 2006/95/EC; Low-Voltage Directive (safety)
- 2004/108/EC; Electromagnetic Compatibility Directive (EMC)

Online Product Certification

Refer to the product Declaration of Conformity (DoC) for additional regulatory compliance information. To obtain product certifications and the DoC for this product, visit ni.com/certification, search by module number or product line, and click the appropriate link in the Certification column.

Environmental Management

National Instruments is committed to designing and manufacturing products in an environmentally responsible manner. NI recognizes that eliminating certain hazardous substances from our products is beneficial not only to the environment but also to NI customers.

For additional environmental information, refer to the *NI and the Environment* Web page at ni.com/environment. This page contains the environmental regulations and directives with which NI complies, as well as other environmental information not included in this document.

Waste Electrical and Electronic Equipment (WEEE)

 **EU Customers** At the end of the product life cycle, all products *must* be sent to a WEEE recycling center. For more information about WEEE recycling centers, National Instruments WEEE initiatives, and compliance with WEEE Directive 2002/96/EC on Waste Electrical and Electronic Equipment, visit ni.com/environment/weee.htm.

电子信息产品污染控制管理办法（中国 RoHS）

 **中国客户** National Instruments 符合中国电子信息产品中限制使用某些有害物质指令 (RoHS)。关于 National Instruments 中国 RoHS 合规性信息，请登录 ni.com/environment/rohs_china。(For information about China RoHS compliance, go to ni.com/environment/rohs_china.)

Battery Replacement and Disposal

 **Battery Directive** This device contains a long-life coin cell battery. If you need to replace it, use the Return Material Authorization (RMA) process or contact an authorized National Instruments service representative. For more information about compliance with the EU Battery Directive 2006/66/EC about Batteries and Accumulators and Waste Batteries and Accumulators, visit ni.com/environment/batterydirective.

¹ Extended-temperature 24/7 option provides 80 GB minimum SATA hard drive.

² Controllers configured for LabVIEW RT provide a 80 GB (minimum) SATA hard drive.

©2010 National Instruments. All rights reserved. CompactRIO, CVI, FieldPoint, LabVIEW, Measurement Studio, National Instruments, National Instruments Alliance Partner, NI, ni.com, NI CompactDAQ, NI-DAQ, and NI TestStand are trademarks of National Instruments. The mark LabWindows is used under a license from Microsoft Corporation. Windows is a registered trademark of Microsoft Corporation in the United States and other countries. Other product and company names listed are trademarks or trade names of their respective companies. A National Instruments Alliance Partner is a business entity independent from National Instruments and has no agency, partnership, or joint-venture relationship with National Instruments.

[My Profile](#) | [RSS](#) | [Privacy](#) | [Legal](#) | [Contact NI](#) © 2014 National Instruments Corporation. All rights reserved.



Artisan Technology Group is your source for quality new and certified-used/pre-owned equipment

- FAST SHIPPING AND DELIVERY
- TENS OF THOUSANDS OF IN-STOCK ITEMS
- EQUIPMENT DEMOS
- HUNDREDS OF MANUFACTURERS SUPPORTED
- LEASING/MONTHLY RENTALS
- ITAR CERTIFIED SECURE ASSET SOLUTIONS

SERVICE CENTER REPAIRS

Experienced engineers and technicians on staff at our full-service, in-house repair center

*InstraView*SM REMOTE INSPECTION

Remotely inspect equipment before purchasing with our interactive website at www.instraview.com ↗

WE BUY USED EQUIPMENT

Sell your excess, underutilized, and idle used equipment. We also offer credit for buy-backs and trade-ins. www.artisanng.com/WeBuyEquipment ↗

LOOKING FOR MORE INFORMATION?

Visit us on the web at www.artisanng.com ↗ for more information on price quotations, drivers, technical specifications, manuals, and documentation

Contact us: (888) 88-SOURCE | sales@artisanng.com | www.artisanng.com