



Artisan Technology Group is your source for quality new and certified-used/pre-owned equipment

- FAST SHIPPING AND DELIVERY
- TENS OF THOUSANDS OF IN-STOCK ITEMS
- EQUIPMENT DEMOS
- HUNDREDS OF MANUFACTURERS SUPPORTED
- LEASING/MONTHLY RENTALS
- ITAR CERTIFIED SECURE ASSET SOLUTIONS

SERVICE CENTER REPAIRS

Experienced engineers and technicians on staff at our full-service, in-house repair center

*InstraView*SM REMOTE INSPECTION

Remotely inspect equipment before purchasing with our interactive website at www.instraview.com ↗

WE BUY USED EQUIPMENT

Sell your excess, underutilized, and idle used equipment. We also offer credit for buy-backs and trade-ins. www.artisanng.com/WeBuyEquipment ↗

LOOKING FOR MORE INFORMATION?

Visit us on the web at www.artisanng.com ↗ for more information on price quotations, drivers, technical specifications, manuals, and documentation

Contact us: (888) 88-SOURCE | sales@artisanng.com | www.artisanng.com

KEITHLEY

PIO-SSR Series

User's Guide



A GREATER MEASURE OF CONFIDENCE

WARRANTY

Hardware

Keithley Instruments, Inc. warrants that, for a period of one (1) year from the date of shipment (3 years for Models 2000, 2001, 2002, 2010 and 2700), the Keithley Hardware product will be free from defects in materials or workmanship. This warranty will be honored provided the defect has not been caused by use of the Keithley Hardware not in accordance with the instructions for the product. This warranty shall be null and void upon: (1) any modification of Keithley Hardware that is made by other than Keithley and not approved in writing by Keithley or (2) operation of the Keithley Hardware outside of the environmental specifications therefore.

Upon receiving notification of a defect in the Keithley Hardware during the warranty period, Keithley will, at its option, either repair or replace such Keithley Hardware. During the first ninety days of the warranty period, Keithley will, at its option, supply the necessary on site labor to return the product to the condition prior to the notification of a defect. Failure to notify Keithley of a defect during the warranty shall relieve Keithley of its obligations and liabilities under this warranty.

Other Hardware

The portion of the product that is not manufactured by Keithley (Other Hardware) shall not be covered by this warranty, and Keithley shall have no duty of obligation to enforce any manufacturers' warranties on behalf of the customer. On those other manufacturers' products that Keithley purchases for resale, Keithley shall have no duty of obligation to enforce any manufacturers' warranties on behalf of the customer.

Software

Keithley warrants that for a period of one (1) year from date of shipment, the Keithley produced portion of the software or firmware (Keithley Software) will conform in all material respects with the published specifications provided such Keithley Software is used on the product for which it is intended and otherwise in accordance with the instructions therefore. Keithley does not warrant that operation of the Keithley Software will be uninterrupted or error-free and/or that the Keithley Software will be adequate for the customer's intended application and/or use. This warranty shall be null and void upon any modification of the Keithley Software that is made by other than Keithley and not approved in writing by Keithley.

If Keithley receives notification of a Keithley Software nonconformity that is covered by this warranty during the warranty period, Keithley will review the conditions described in such notice. Such notice must state the published specification(s) to which the Keithley Software fails to conform and the manner in which the Keithley Software fails to conform to such published specification(s) with sufficient specificity to permit Keithley to correct such nonconformity. If Keithley determines that the Keithley Software does not conform with the published specifications, Keithley will, at its option, provide either the programming services necessary to correct such nonconformity or develop a program change to bypass such nonconformity in the Keithley Software. Failure to notify Keithley of a nonconformity during the warranty shall relieve Keithley of its obligations and liabilities under this warranty.

Other Software

OEM software that is not produced by Keithley (Other Software) shall not be covered by this warranty, and Keithley shall have no duty or obligation to enforce any OEM's warranties on behalf of the customer.

Other Items

Keithley warrants the following items for 90 days from the date of shipment: probes, cables, rechargeable batteries, diskettes, and documentation.

Items not Covered under Warranty

This warranty does not apply to fuses, non-rechargeable batteries, damage from battery leakage, or problems arising from normal wear or failure to follow instructions.

Limitation of Warranty

This warranty does not apply to defects resulting from product modification made by Purchaser without Keithley's express written consent, or by misuse of any product or part.

Disclaimer of Warranties

EXCEPT FOR THE EXPRESS WARRANTIES ABOVE KEITHLEY DISCLAIMS ALL OTHER WARRANTIES, EXPRESS OR IMPLIED, INCLUDING WITHOUT LIMITATION, ALL IMPLIED WARRANTIES OF MERCHANTABILITY AND FITNESS FOR A PARTICULAR PURPOSE. KEITHLEY DISCLAIMS ALL WARRANTIES WITH RESPECT TO THE OTHER HARDWARE AND OTHER SOFTWARE.

Limitation of Liability

KEITHLEY INSTRUMENTS SHALL IN NO EVENT, REGARDLESS OF CAUSE, ASSUME RESPONSIBILITY FOR OR BE LIABLE FOR: (1) ECONOMICAL, INCIDENTAL, CONSEQUENTIAL, INDIRECT, SPECIAL, PUNITIVE OR EXEMPLARY DAMAGES, WHETHER CLAIMED UNDER CONTRACT, TORT OR ANY OTHER LEGAL THEORY, (2) LOSS OF OR DAMAGE TO THE CUSTOMER'S DATA OR PROGRAMMING, OR (3) PENALTIES OR PENALTY CLAUSES OF ANY DESCRIPTION OR INDEMNIFICATION OF THE CUSTOMER OR OTHERS FOR COSTS, DAMAGES, OR EXPENSES RELATED TO THE GOODS OR SERVICES PROVIDED UNDER THIS WARRANTY.



Keithley Instruments, Inc.

28775 Aurora Road • Cleveland, Ohio 44139 • 440-248-0400 • Fax: 440-248-6168
1-888-KEITHLEY (534-8453) • www.keithley.com

Sales Offices:	BELGIUM:	Bergensesteenweg 709 • B-1600 Sint-Pieters-Leeuw • 02-363 00 40 • Fax: 02/363 00 64
	CHINA:	Yuan Chen Xin Building, Room 705 • 12 Yumin Road, Dewai, Madian • Beijing 100029 • 8610-6202-2886 • Fax: 8610-6202-2892
	FINLAND:	Tietäjäntie 2 • 02130 Espoo • Phone: 09-54 75 08 10 • Fax: 09-25 10 51 00
	FRANCE:	3, allée des Garays • 91127 Palaiseau Cédex • 01-64 53 20 20 • Fax: 01-60 11 77 26
	GERMANY:	Landsberger Strasse 65 • 82110 Germering • 089/84 93 07-40 • Fax: 089/84 93 07-34
	GREAT BRITAIN:	Unit 2 Commerce Park, Brunel Road • Theale • Berkshire RG7 4AB • 0118 929 7500 • Fax: 0118 929 7519
	INDIA:	Flat 2B, Willocrissa • 14, Rest House Crescent • Bangalore 560 001 • 91-80-509-1320/21 • Fax: 91-80-509-1322
	ITALY:	Viale San Gimignano, 38 • 20146 Milano • 02-48 39 16 01 • Fax: 02-48 30 22 74
	JAPAN:	New Pier Takeshiba North Tower 13F • 11-1, Kaigan 1-chome • Minato-ku, Tokyo 105-0022 • 81-3-5733-7555 • Fax: 81-3-5733-7556
	KOREA:	2FL., URI Building • 2-14 Yangjae-Dong • Seocho-Gu, Seoul 137-888 • 82-2-574-7778 • Fax: 82-2-574-7838
	NETHERLANDS:	Postbus 559 • 4200 AN Gorinchem • 0183-635333 • Fax: 0183-630821
	SWEDEN:	c/o Regus Business Centre • Frosundaviks Allé 15, 4tr • 169 70 Solna • 08-509 04 679 • Fax: 08-655 26 10
	SWITZERLAND:	Kriesbachstrasse 4 • 8600 Dübendorf • 01-821 94 44 • Fax: 01-820 30 81
	TAIWAN:	1FL., 85 Po Ai Street • Hsinchu, Taiwan, R.O.C. • 886-3-572-9077 • Fax: 886-3-572-9031

The information contained in this manual is believed to be accurate and reliable. However, the manufacturer assumes no responsibility for its use; nor for any infringements of patents or other rights of third parties that may result from its use. No license is granted by implication or otherwise under any patent rights of the manufacturer.

Note: The manufacturer shall not be liable for any special, incidental, or consequential damages related to the use of this product. This product is not designed with components of a level of reliability that is suited for use in life support or critical applications.

Note: DriverLINX, SSTNET, and LabOBJX are registered trademarks and DriverLINX/VB is a trademark of Scientific Software Tools, Inc.

Microsoft and Windows are registered trademarks and Visual C++ and Visual Basic are trademarks of Microsoft Corporation.

Borland is a registered trademark and Borland C++, Delphi, and Turbo Pascal are trademarks of Borland International, Inc.

IBM is a registered trademark of International Business Machines Corporation.

Acrobat is a registered trademark of Adobe Systems Incorporated.

All other brand and product names are trademarks or registered trademarks of their respective companies.

Copyright © Keithley Instruments, Inc., 1999, 1995.

All rights reserved. Reproduction or adaptation of any part of this documentation beyond that permitted by Section 117 of the 1979 United States Copyright Act without permission of the Copyright owner is unlawful.

KEITHLEY INSTRUMENTS, INC.

28775 Aurora Road

Cleveland, OH 44139

TEL: (440) 248-0400

FAX: (440) 248-6168

Website: <http://www.keithley.com>

PIO-SSR Series User's Guide

Revision C - April 2001
Part Number: 95390

The following safety precautions should be observed before using this product and any associated instrumentation. Although some instruments and accessories would normally be used with non-hazardous voltages, there are situations where hazardous conditions may be present.

This product is intended for use by qualified personnel who recognize shock hazards and are familiar with the safety precautions required to avoid possible injury. Read and follow all installation, operation, and maintenance information carefully before using the product. Refer to the manual for complete product specifications.

If the product is used in a manner not specified, the protection provided by the product may be impaired.

The types of product users are:

Responsible body is the individual or group responsible for the use and maintenance of equipment, for ensuring that the equipment is operated within its specifications and operating limits, and for ensuring that operators are adequately trained.

Operators use the product for its intended function. They must be trained in electrical safety procedures and proper use of the instrument. They must be protected from electric shock and contact with hazardous live circuits.

Maintenance personnel perform routine procedures on the product to keep it operating properly, for example, setting the line voltage or replacing consumable materials. Maintenance procedures are described in the manual. The procedures explicitly state if the operator may perform them. Otherwise, they should be performed only by service personnel.

Service personnel are trained to work on live circuits, and perform safe installations and repairs of products. Only properly trained service personnel may perform installation and service procedures.

Keithley products are designed for use with electrical signals that are rated Installation Category I and Installation Category II, as described in the International Electrotechnical Commission (IEC) Standard IEC 60664. Most measurement, control, and data I/O signals are Installation Category I and must not be directly connected to mains voltage or to voltage sources with high transient over-voltages. Installation Category II connections require protection for high transient over-voltages often associated with local AC mains connections. Assume all measurement, control, and data I/O connections are for connection to Category I sources unless otherwise marked or described in the Manual.

Exercise extreme caution when a shock hazard is present. Lethal voltage may be present on cable connector jacks or test fixtures. The American National Standards Institute (ANSI) states that a shock hazard exists when voltage levels greater than 30V RMS, 42.4V peak, or 60VDC are present. **A good safety practice is to expect that hazardous voltage is present in any unknown circuit before measuring.**

Operators of this product must be protected from electric shock at all times. The responsible body must ensure that operators are prevented access and/or insulated from every connection point. In some cases, connections must be exposed to potential human contact. Product operators in these circumstances must be trained to protect themselves from the risk of electric shock. If the circuit is capable of operating at or above 1000 volts, **no conductive part of the circuit may be exposed.**

Do not connect switching cards directly to unlimited power circuits. They are intended to be used with impedance limited sources. NEVER connect switching cards directly to AC mains. When connecting sources to switching cards, install protective devices to limit fault current and voltage to the card.

Before operating an instrument, make sure the line cord is connected to a properly grounded power receptacle. Inspect the connecting cables, test leads, and jumpers for possible wear, cracks, or breaks before each use.

When installing equipment where access to the main power cord is restricted, such as rack mounting, a separate main input power disconnect device must be provided, in close proximity to the equipment and within easy reach of the operator.

For maximum safety, do not touch the product, test cables, or any other instruments while power is applied to the circuit under test. ALWAYS remove power from the entire test system and discharge any capacitors before: connecting or disconnecting cables or jumpers, installing or removing switching cards, or making internal changes, such as installing or removing jumpers.

Do not touch any object that could provide a current path to the common side of the circuit under test or power line (earth) ground. Always make measurements with dry hands while standing on a dry, insulated surface capable of withstanding the voltage being measured.



The instrument and accessories must be used in accordance with its specifications and operating instructions or the safety of the equipment may be impaired.

Do not exceed the maximum signal levels of the instruments and accessories, as defined in the specifications and operating information, and as shown on the instrument or test fixture panels, or switching card.

When fuses are used in a product, replace with same type and rating for continued protection against fire hazard.

Chassis connections must only be used as shield connections for measuring circuits, NOT as safety earth ground connections.

If you are using a test fixture, keep the lid closed while power is applied to the device under test. Safe operation requires the use of a lid interlock.

If  or  is present, connect it to safety earth ground using the wire recommended in the user documentation.

The  symbol on an instrument indicates that the user should refer to the operating instructions located in the manual.

The  symbol on an instrument shows that it can source or measure 1000 volts or more, including the combined effect of normal and common mode voltages. Use standard safety precautions to avoid personal contact with these voltages.

The **WARNING** heading in a manual explains dangers that might result in personal injury or death. Always read the associated information very carefully before performing the indicated procedure.

The **CAUTION** heading in a manual explains hazards that could damage the instrument. Such damage may invalidate the warranty.

Instrumentation and accessories shall not be connected to humans.

Before performing any maintenance, disconnect the line cord and all test cables.

To maintain protection from electric shock and fire, replacement components in mains circuits, including the power transformer, test leads, and input jacks, must be purchased from Keithley Instruments. Standard fuses, with applicable national safety approvals, may be used if the rating and type are the same. Other components that are not safety related may be purchased from other suppliers as long as they are equivalent to the original component. (Note that selected parts should be purchased only through Keithley Instruments to maintain accuracy and functionality of the product.) If you are unsure about the applicability of a replacement component, call a Keithley Instruments office for information.

To clean an instrument, use a damp cloth or mild, water based cleaner. Clean the exterior of the instrument only. Do not apply cleaner directly to the instrument or allow liquids to enter or spill on the instrument. Products that consist of a circuit board with no case or chassis (e.g., data acquisition board for installation into a computer) should never require cleaning if handled according to instructions. If the board becomes contaminated and operation is affected, the board should be returned to the factory for proper cleaning/servicing.

Table of Contents

Preface

1 Overview

Features	1-2
Applications	1-2
Supporting Software	1-3
Accessories	1-4

2 Functional Description

3 Setup and Installation

Unpacking and Inspecting a Board	3-1
Installing and Configuring DriverLINX	3-2
Before Installing DriverLINX	3-2
Selecting the DriverLINX Components to Install	3-3
Installing DriverLINX	3-3
Configuring a Board	3-5
Setting the Base I/O Address	3-6
Setting the IRQ Level	3-8
Clamping Cables to the Board	3-10
Installing Cable Shielding	3-12
Installing a Board	3-15
Configuring DriverLINX	3-16

4 Cabling and Wiring

Connecting an STP-50	4-1
Connecting a PB-24 or PB-24SM	4-2
Monitoring Contact Closure at an Input	4-4
Eliminating Contact Bounce	4-4
Boosting Relay Drive Current	4-5

5 Testing Your Board

I/O Bit Tests	5-1
General Information	5-1
Output Set Test	5-6
Input Read Test	5-10

6	Programming Options	
	Selecting an Application Programming Interface	6-1
	DriverLINX Interface	6-1
	Direct I/O Application Programming Interface	6-3
	Installing the Direct I/O Driver	6-4
	Configuring the Direct I/O Driver	6-4
	Programming the Direct I/O Interface	6-4
	IISAPIO Intel 8255 Interface	6-4
	Using the Direct I/O Driver in Visual Basic	6-5
	Creating a Simple Visual Basic Application	6-6
	Register-Level Programming	6-7
	I/O Address Maps	6-8
	Control Word Register	6-10
	IRQ Control Registers 1 and 2	6-11
	IRQ Status Registers 1 and 2	6-13
7	Troubleshooting	
	Using the DriverLINX Event Viewer	7-1
	Device Initialization Error Messages	7-2
	Problem Isolation	7-2
	Identifying Symptoms and Possible Causes	7-2
	Testing the Board and Host Computer	7-5
	Testing the Accessory Slot and I/O Connections	7-6
	Technical Support	7-6
A	Specifications	
B	Connector Pin Assignments	
C	CE Mark Information for the PIO-SSR Series	
	Limitation of Certification	C-1
	Declaration of Conformity	C-2
	Cabling Instructions for the CE Mark Configuration	C-3

Index

List of Figures

Figure 2-1.	Block Diagram of a PIO-SSR-24	2-1
Figure 2-2.	Block Diagram of PIO-SSR-48	2-2
Figure 2-3.	Block Diagram of PIO-SSR-120	2-3
Figure 3-1.	Switch and Jumper Locations	3-6
Figure 3-2.	Base-Address Switch Values	3-7
Figure 3-3.	Jumper Block for Selection of IRQ Level	3-8
Figure 3-4.	Cable Clamp on a Mounting Plate	3-10
Figure 3-5.	Cabling in Place	3-11
Figure 3-6.	Cable Clamp Securing Single Cable	3-11
Figure 3-7.	Cabling Taped to Show Shield Boundary	3-12
Figure 3-8.	Cabling Wrapped with Jacket to Tape Boundary	3-12
Figure 3-9.	Jacket Trimmed with Scissors to Make ½-Inch Flaps	3-13
Figure 3-10.	Jacket with Flaps Folded Back to Expose Shield Surface	3-13
Figure 3-11.	Cabling Reconnected, Placing Shield Surface in Line with Clamp	3-13
Figure 3-12.	Detail of Clamped Cable Showing Installed Jacket	3-14
Figure 4-1.	Connecting an STP-50 to a PIO-SSR Series Board	4-1
Figure 4-2.	Connecting Two STP-50s to a PIO-SSR Series Board	4-2
Figure 4-3.	Connecting a PB-24 or PB-24SM to a PIO-SSR Series Board	4-2
Figure 4-4.	Connecting Two PB-24 or PB-24SM Accessories to a PIO-SSR Series Board	4-3
Figure 4-5.	Contact-Closure Monitoring at an Input of a PIO-SSR Series Board	4-4
Figure 4-6.	Bounce Circuit for an Input of a PIO-SSR Series Board	4-4
Figure 4-7.	NPN Transistor Relay Control for an Output of a PIO-SSR Series Board	4-5
Figure 5-1.	An AIO Panel example	5-2
Figure 5-2.	DIO channel tab example	5-3
Figure 5-3.	Configuring the digital I/O channels as inputs and outputs	5-5
Figure 5-4.	Configuring channel 0 for output bit pattern A	5-5
Figure 5-5.	An AIO Panel example	5-7

Figure 5-6.	Configuring the digital I/O channels as inputs and outputs	5-8
Figure 5-7.	Configuring channel 0 for output bit pattern A	5-8
Figure 5-8.	Configuring channel 0 for output bit pattern B	5-9
Figure 6-1.	Block Diagram of IRQ Circuit	6-11
Figure B-1.	Pin Assignments for I/O Connectors J1 to J5	B-1
Figure B-2.	Pin Assignments for Edge Connector on CAB-SSR Cable	B-2

List of Tables

Table 3-1.	Priorities for IRQ Levels	3-9
Table 6-1.	I/O Address Map for a PIO-SSR-24	6-8
Table 6-2.	I/O Address Map for a PIO-SSR-48	6-8
Table 6-3.	I/O Address Map for a PIO-SSR-120	6-9
Table 6-4.	Bit Assignments for a Control Word Register	6-10
Table 6-5.	Addresses of IRQ Control Register Bits for a PIO-SSR-24	6-12
Table 6-6.	Addresses of IRQ Control Register Bits for a PIO-SSR-48	6-12
Table 6-7.	Addresses of IRQ Control Register Bits for a PIO-SSR-120	6-13
Table 7-1.	Troubleshooting Information	7-3
Table A-1.	Digital Input/Output Specifications	A-1
Table A-2.	Interrupt Request Specifications	A-1
Table A-3.	Input Parameter Specifications	A-2
Table A-4.	Output Parameter Specifications	A-2
Table A-5.	General Specifications	A-2

Preface

The *PIO-SSR Series User's Guide* contains information and instructions for handling and using PIO-SSR-24, PIO-SSR-48, and PIO-SSR-120 boards. Unless this guide refers specifically to one or more of these models, it refers collectively to all models as the PIO-SSR Series.

To follow the information and instructions contained in this manual, you must be familiar with data-acquisition principles, with your application, and with an IBM PC AT[®] (or equivalent) in the MS DOS[®] or Windows environments. The software that accompanies each board is compatible with Windows 95/98 and Windows NT.

The *PIO-SSR Series User's Guide* is organized as follows:

- Section 1 provides an overview of the hardware and descriptions of features, applications, supporting software, and accessories.
- Section 2 provides a block diagram and descriptions of major features.
- Section 3 describes how to unpack, configure, and install the board and how to install the software.
- Section 4 describes how to connect accessories and circuits.
- Section 5 describes how to start up and use the DriverLINX AIO Panel test program; you use this utility to test your board.
- Section 6 describes the I/O registers and programming options for the board.
- Section 7 describes how to isolate common problems, how to troubleshoot your system, and how to obtain technical support.
- Appendix A contains specifications.
- Appendix B contains pin assignments for the I/O connectors.
- An index completes the manual.

1

Overview

PIO-SSR Series boards are multi-channel, parallel, digital I/O devices. The boards feature high-current-driver, programmable, TTL-level I/O channels to provide a flexible interface for SSR (solid-state relay) modules and for a variety of parallel I/O devices, including instruments, displays, and user-assembled systems. The PIO-SSR-120 is a 120-channel board, the PIO-SSR-48 a 48-channel board, and the PIO-SSR-24 a 24-channel board. Each of these boards fits an expansion slot of an IBM PC AT or equivalent. This section describes the features, applications, supporting software, and accessories for this series of boards.

The PIO-SSR Series boards and computer with DriverLINX software require:

- an IBM PC or compatible (386, or Pentium CPU) with minimum of 2 MB of memory
- at least one floppy disk drive, and one fixed disk drive
- Microsoft Windows 95/98, or Windows NT 4.0 or higher
- a compiler supporting Microsoft Windows development
- a mouse is highly recommended

Features

Major features of PIO-SSR Series boards are as follows:

- Each group of 24 digital I/O lines terminates in an onboard, 50-pin header whose pin assignments are compatible with industry-standard PB-24 and PB-24SM solid-state-relay baseboards.
- Three board versions are available to drive one, two, or five PB-24 baseboards from a single expansion slot of your computer.
- Each group of 24 digital I/O channels emulates Mode 0 of an Intel 8255, allowing most of the current application software for data acquisition to work seamlessly with PIO-SSR Series boards.
- All boards power up with all lines configured as inputs and pulled high.
- All boards provide high-current-drive capability.
- All boards provides flexible interrupt capability.
- An onboard 10k Ω pull-up resistor connected between each channel and the +5V gives CMOS compatibility for TTL signals.
- The software that accompanies each board is compatible with Windows 3.x and Windows 95.
- All PIO-SSR Series boards are $\frac{2}{3}$ size.

Applications

Typical applications of PIO-SSR Series boards are as follows:

- Machine control
- Process monitoring and control
- Control of solenoids, pumps, motors, and others
- Contact-closure monitoring

Supporting Software

The following software is available for operating PIO-SSR boards:

- **PIO-SSR standard software package** — Shipped with PIO-SSR boards. Includes DriverLINX for Microsoft Windows 95/98 or Windows NT and function libraries for writing application programs under Windows in a high-level language such as Microsoft Visual C++, Microsoft Visual Basic; Borland Delphi support files; LabVIEW; utility programs; and language-specific example programs.
- **DriverLINX** — the high-performance real-time data-acquisition device drivers for Windows application development including:
 - *DriverLINX API DLLs* and drivers supporting the PIO-SSR hardware
 - *AIO Panel* — A DriverLINX program that verifies the installation and configuration of DriverLINX to your PIO-SSR board and demonstrates several virtual bench-top instruments
 - *Learn DriverLINX* — an interactive learning and demonstration program for DriverLINX that includes a Digital Storage Oscilloscope
 - *Source Code* — for the sample programs
 - *DriverLINX Application Programming Interface files* — for the PIO-SSR compiler
 - *DriverLINX On-line Help System* — provides immediate help as you operate DriverLINX
 - *Supplemental Documentation* — on DriverLINX installation and configuration; analog and digital I/O programming; counter/timer programming; technical reference; and information specific to the PIO-SSR hardware.
- **PIO-SSR Series utilities** — The following utilities are provided as part of the PIO-SSR Series standard software package:
 - *Test Utility*

Accessories

The following accessories are available for use with a PIO-SSR Series board:

- **PB-24** — A 24-channel baseboard for standard-size SSR modules.
- **PB-24SM** — A 24-channel baseboard for miniature SM Series SSR modules.
- **Solid State Relay Modules** — Refer to Keithley's Products catalog for module choices and descriptions.
- **CAB-SSR** — A 3-foot ribbon cable for connecting a PIO-SSR Series board to a PB-24 or PB-24SM accessory.
- **CACC-2000** — A 2-foot ribbon cable for connecting a PIO-SSR Series board to an STP-50 accessory.
- **STP-50** — Universal screw-terminal panel with a 50-pin male header.
- **Jacket** — Zipper-style shielded tubing available by the foot for shielding flat cables; this shielding is designated *Jacket* for a 2-foot length or *Jacket nn* for custom-cut lengths (refer to the Keithley's Products catalog for more information).

2

Functional Description

This section describes the features and operating characteristics of PIO-SSR Series boards. Figure 2-1 shows a block diagram of a PIO-SSR-24; Figure 2-2 shows a block diagram of a PIO-SSR-48; Figure 2-3 shows a block diagram of a PIO-SSR-120.

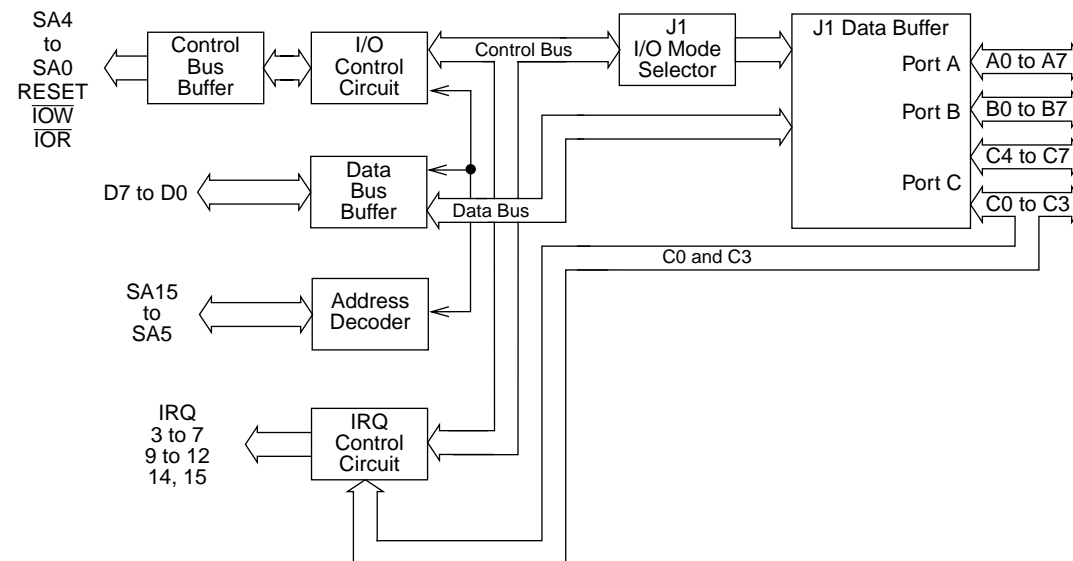

Figure 2-1. Block Diagram of a PIO-SSR-24

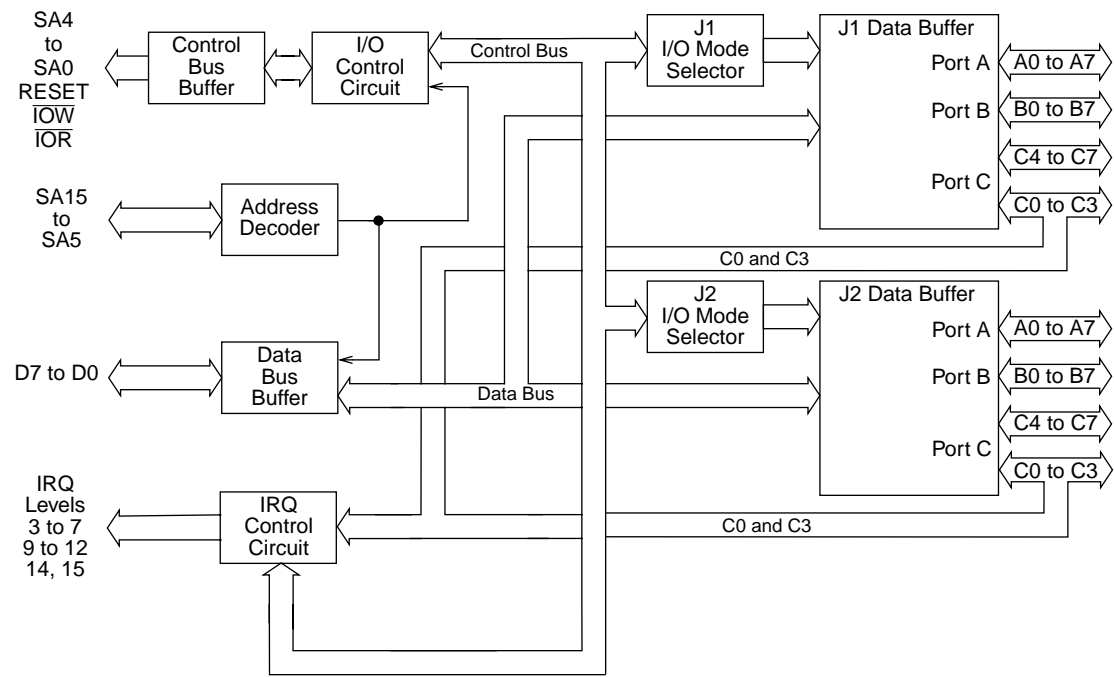

Figure 2-2. Block Diagram of PIO-SSR-48

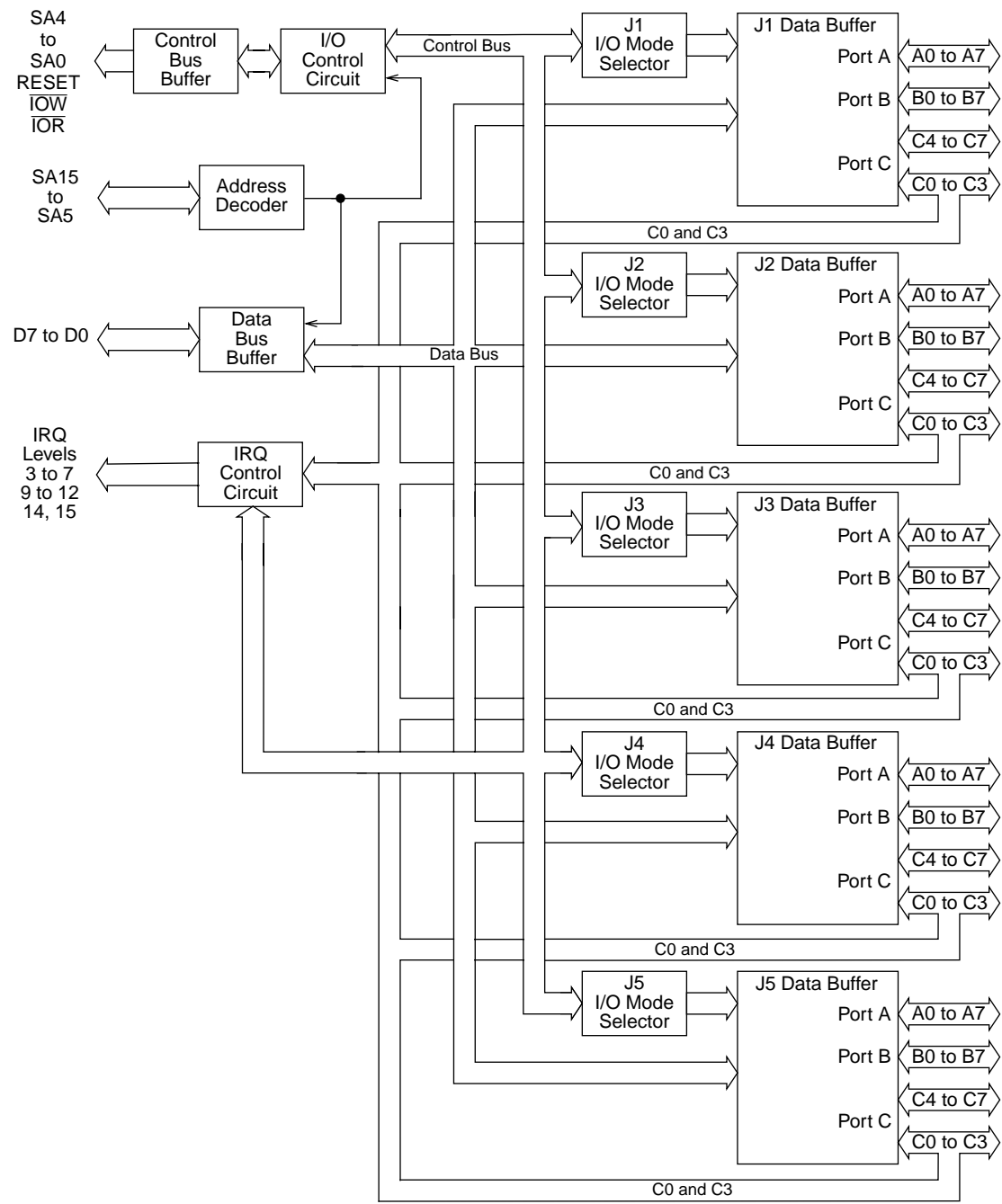

Figure 2-3. Block Diagram of PIO-SSR-120

Functional features of a PIO-SSR Series board are described as follows:

- Using software, you can set each port as an input or an output.
- The capacity of each channel (when set as an output) is 24mA of sink current or 15mA of source current, allowing a board to drive industry-standard solid-state relays. The SSRs allow up to 4000V_{rms} of isolation and AC or DC voltage sensing up to 240V.
- All channels in all ports are TTL-compatible and are not electrically isolated from external circuits.
- Channels on any PIO-SSR Series board are structured in groups of 24; a PIO-SSR-24 contains one 24-channel group, a PIO-SSR-48 contains two 24-channel groups, and a PIO-SSR-120 contains five 24-channel groups.
- Each 24-channel group is accessible through an onboard, 50-pin, male connector whose pin assignments are compatible with the industry-standard PB-24 and PB-24SM solid-state-relay-module baseboards.
- Each 24-channel group emulates the Mode 0 operation of the Intel 8255A PPI (Programmable Peripheral Interface) integrated circuit.
- A single group comprises three 8-channel ports whose designations are Port A, Port B, and Port C.
- While Port A and Port B are each used as 8-channel ports, Port C is used as one 8-channel port or two 4-channel ports.
- Input channels C0 and C3 of every Port C on a board can each generate an interrupt request (IRQ) signal for gating into a single, jumper-selectable IRQ level.
- The IRQ levels supported by PIO-SSR Series boards are 3 to 7, 9 to 12, 14, and 15.
- The input requirement for an interrupt is the rising edge of a TTL-compatible input signal.
- You can disable the interrupts through software.

3

Setup and Installation

This section describes how to unwrap and inspect your board, install the software, configure your board, create a configuration file, install the board cabling, and install your board in the computer. These tasks are described in the subsections that follow.

Unpacking and Inspecting a Board

After removing the wrapped board from its outer shipping carton, proceed as follows:

1. Your PIO-SSR Series board is packaged at the factory in an anti-static wrapper that must not be removed until you have discharged any static electricity by either of the following methods:
 - If you are equipped with a wrist grounding strap, you discharge static electricity as soon as you hold the wrapped board.
 - If you are not equipped with a wrist grounding strap, discharge static electricity by holding the wrapped board in one hand while placing your other hand firmly on a metal portion of the computer chassis (your computer must be turned off, but grounded).
2. Carefully unwrap the board from its anti-static wrapping material. (Store the wrapping material for future use.)
3. Inspect the board for signs of damage; if damage is apparent, return the board to the factory. (See *Technical Support* on page 7-6).
4. Check the contents of your package against the packing list; report any missing items to the factory immediately.
5. If inspection is satisfactory, proceed to install the software.

Installing and Configuring DriverLINX

Important: As a precaution against a system crash the first time you install and test any new hardware, you should exit all other programs and, if you use a disk cache, disable write caching. If the system does crash and you're using disk compression software or a disk cache utility, as a precaution after any crash, run the utility that checks the directory structures.

Important: Before you begin installing any hardware or software for the PIO-SSR, read the *DriverLINX Installation and Configuration Guide* and the *Using DriverLINX with your Hardware Keithley PIO Series* manuals that are packaged with the DriverLINX software. They are accessed from the DriverLINX CD-ROM after you have installed Adobe Acrobat.

Before Installing DriverLINX

1. Inventory your PIO-SSR board's configuration settings.
2. Determine the resources your PIO-SSR board requires.
3. Inventory your computer's resources already allocated to other installed devices.
4. Determine whether your computer has sufficient resources for your PIO-SSR board.
5. Determine whether your PIO-SSR board can use your computer's free resources.
6. Set any jumpers/switches to configure your PIO-SSR board to use your computer's free resources.
7. Set any other jumpers/switches to configure your PIO-SSR board as desired.

Selecting the DriverLINX Components to Install

For your convenience in installing and un-installing just the DriverLINX components you need, the DriverLINX CD Browser will assist you in selecting the components to install:

- **Install Drivers** — This required component installs only the files you need for configuring your hardware and running third-party data-acquisition applications that require DriverLINX.
- **Install Interfaces** — This optional component installs the files and example programs that you will need to develop custom applications for DriverLINX using C/C++, Visual Basic, Delphi, and LabVIEW.
- **Install Documentation** — This optional component installs electronic documentation for DriverLINX that you can read, search, and print using the Adobe Acrobat Reader.
- **Install Acrobat** — This optional component installs the Adobe Acrobat Reader for the DriverLINX electronic documentation.

Installing DriverLINX

1. Insert the DriverLINX CD-ROM into your computer's CD-ROM Drive.
2. Start the DriverLINX setup program. On most systems, wait a few seconds for automatic startup. Otherwise, run the setup.exe program from the CD-ROM.
3. The DriverLINX CD-ROM Browser Map window appears on the screen. Click Install Drivers, and follow the series of on-screen instructions.

Note: To display an explanation of a menu option on the DriverLINX CD browser map that appears next and on subsequent setup screens, place the mouse pointer over the menu item. A star next to a menu item means that the item was selected previously.

4. Select Read Me First, and follow the instructions.

5. Select Install Documentation. If you do not have Adobe Acrobat installed on your computer, install it by selecting Install Adobe Acrobat.
6. Open the manuals appropriate to the PIO-SSR installation and read them before installing your PIO-SSR board or configuring DriverLINX:
 - *Installation and Configuration*
 - *Using DriverLINX with Your Hardware—Keithley PIO Series*
 - *DriverLINX Technical Reference Manual*
 - *DriverLINX Digital I/O Programming Guide*
 - *DriverLINX Analog I/O Programming Guide*
 - *DriverLINX Counter/Timer Programming Guide*
 - *Appendix, I/O Port, Interrupt, and DMA Channel Usage*
 - Other manuals appropriate to your installation.
7. Before installing a PIO-SSR board in your computer, make sure that the switches are set appropriately and that you have noted the switch settings so that you can match these settings when you program the configuration using DriverLINX. Refer to the *DriverLINX Installation and Configuration Guide* and *Using DriverLINX with Your Hardware—Keithley PIO Series* manuals.
8. Install your PIO-SSR board into an appropriate free slot in your computer when DriverLINX prompts you to do so.

Note: If switches on the board are changed after the software has been installed, the software will need to be reconfigured.

Refer to the documentation provided with your computer for more information on installing boards.

Follow the DriverLINX on-screen instructions for installation of drivers and interfaces. Refer to the *DriverLINX Installation and Configuration Guide* and *Using DriverLINX with Your Hardware—Keithley PIO Series* manuals.

Note: Be sure to note and follow all programming differences between installations for Windows NT and Windows 95/98.

Note: Typically, base addresses between 300h and 370h are available for use. However, keep in mind that a network board, a sound board, a CD-ROM, or other data acquisition board may use a base address within this space.

DriverLINX allows you to set base addresses between 200h and 3F0h only. Therefore, if you are using your PIO-SSR board with software that requires a configuration file, you must specify an even boundary of four I/O addresses within the range of 200h to 3F8h.

Configuring a Board

Keithley configures your PIO-SSR Series board by presetting a base I/O address and an IRQ level. While the factory settings are suitable for most installations, ensure these settings are not already in use by other devices in your computer. If your board requires reconfiguration, you must set a new base address and/or select a new IRQ level by setting the base-address switches and IRQ-level jumper. These components are located as shown in Figure 3-1.

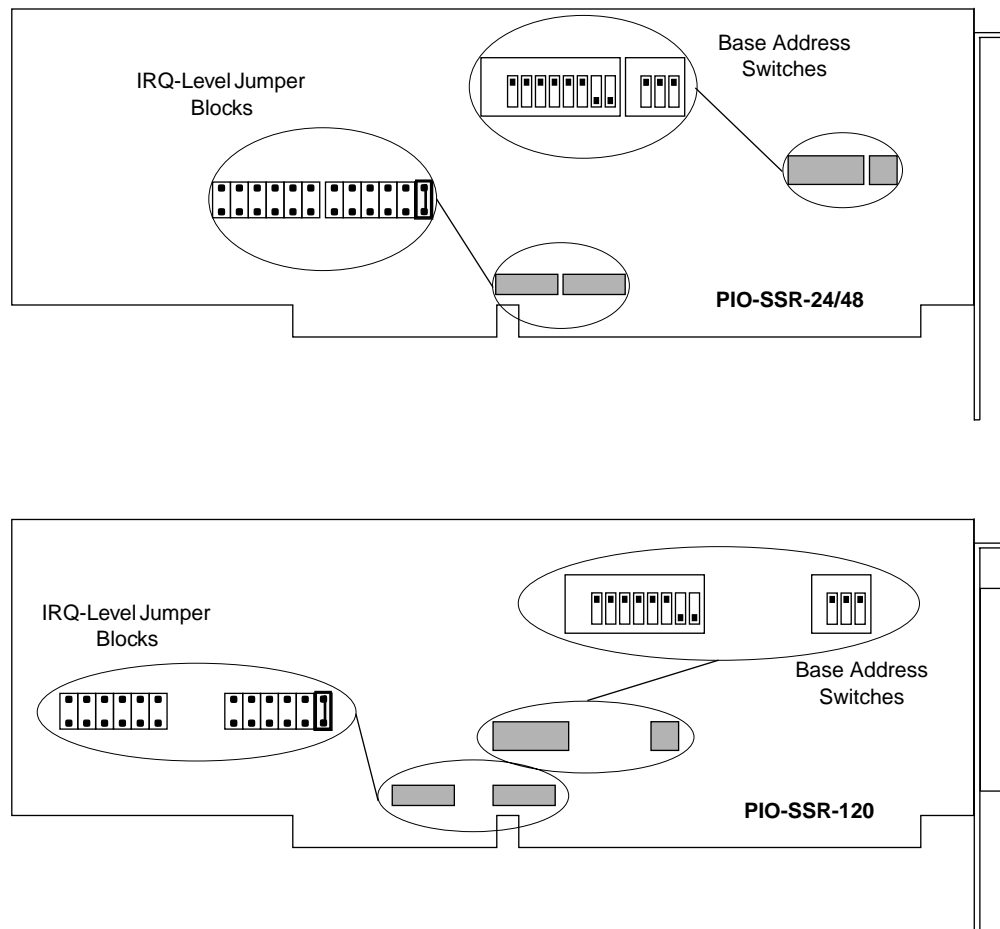

Figure 3-1. Switch and Jumper Locations

The following subsections describe how to set the base address and IRQ level.

Setting the Base I/O Address

Addresses in the I/O space of your computer can range from 0000h to FFFFh, for a total of 65,535 locations. IBM recommends a base I/O address between 100h and 3FFh only and reserves some addresses in this range computer and I/O device use. You can set your PIO-SSR Series

board for an address well beyond the 100h to 3FFh range; Keithley recommends *300h, *700h, *B00h, or *F00h (where * is any number in the range of 0 to Fh) as valid base I/O addresses. You can also assign your board an address that is 400h, 800h, or C00h above the upper limit of 3FFh recommended by IBM.

Caution: Writing to a base I/O address above 400h can sometimes draw response from a device using an address below 400h. For example, an address of 01F0h is used by many computers for a fixed disk. If the disk drive controller board sees only the 10 least significant address lines (A0 to A9), then writing to 1F0h, 5F0h, 9F0h, or DF0h could inadvertently activate the disk drive controller board.

The base-address switches are preset at the factory for a default base I/O address of 300h (the address reserved by many computers for a prototype board). If this address is already assigned to another device in your computer, reset the switches for a different I/O address. Use the information shown in Figure 3-2 to determine settings for a new address.

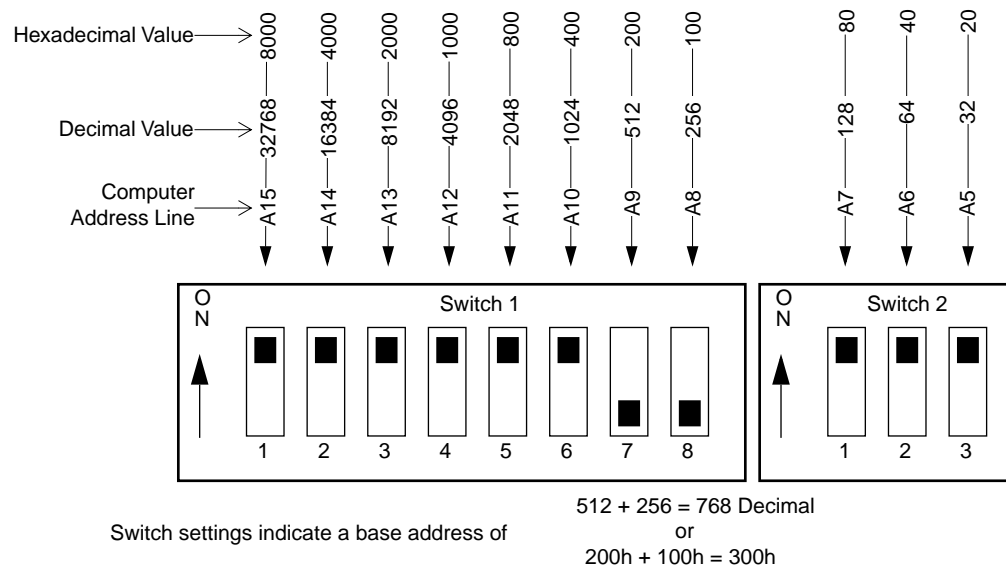

Figure 3-2. Base-Address Switch Values

Note: A base I/O address switch has value only when set to its OFF position.

Notice that the least significant address line in Figure 3-2 is A5. This line has a decimal value of 32; therefore, the address you select is on a 32-byte boundary, giving the board access to 32 I/O address ports (the board actually uses a maximum of only 22 address ports, as shown in the I/O address maps of Section 6).

Setting the IRQ Level

A PIO-SSR Series board can generate an IRQ signal on the rising edge of any input signal from either the C0 or C3 input channel. To gate the IRQ signal to your computer, you must place a jumper on one of the IRQ-level settings of the jumper block. The IRQ-level options on the jumper block are 3 to 7, 9 to 12, 14, and 15. The jumper block also contains a position labelled X for no connection. Your board is preset at the factory for the X position, as shown in Figure 3-3.

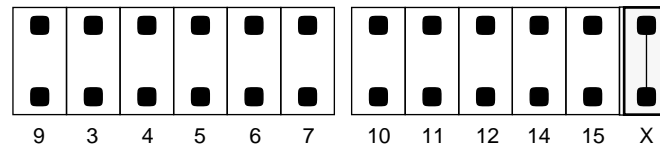

Figure 3-3. Jumper Block for Selection of IRQ Level

Priorities for the IRQ levels are shown in Table 3-1.

Table 3-1. Priorities for IRQ Levels

Priority	IRQ Level
First	9
Second	10
Third	11
Fourth	12
Fifth	14
Sixth	15
Seventh	3
Eighth	4
Ninth	5
Tenth	6
Eleventh	7

Clamping Cables to the Board

The mounting plate of your PIO-SSR Series board contains an adjustable cable clamp that can secure up to five flat cables (shown in Figure 3-4 with a single cable).

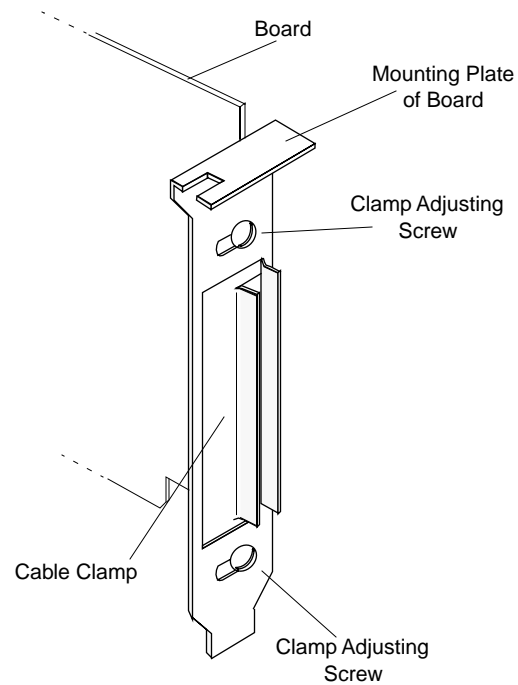

Figure 3-4. Cable Clamp on a Mounting Plate

To clamp one or more cables to your board, use the following procedure:

1. Remove the two clamp-adjusting screws and the clamp from the board's mounting plate.
2. Feed a cable through the hole in the mounting plate, and plug the cable connector into the I/O connector nearest the mounting plate (if your board contains more than one I/O connector).

3. If your board is using more than one cable, feed the next cable through the hole in the mounting plate, and plug the cable connector into the next available I/O connector.
4. Repeat step 3 until all cables are in place on the board, as shown in Figure 3-5.

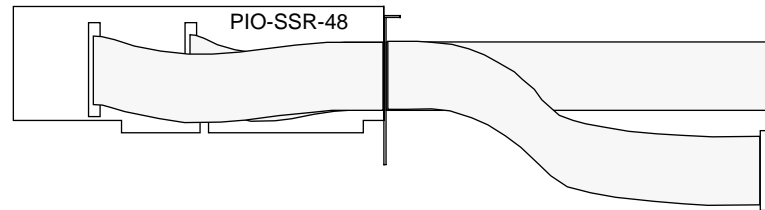

Figure 3-5. Cabling in Place

5. Re-install the clamp and clamp-adjusting screws so that the clamp holds the cabling firmly in place, as shown in Figure 3-6.

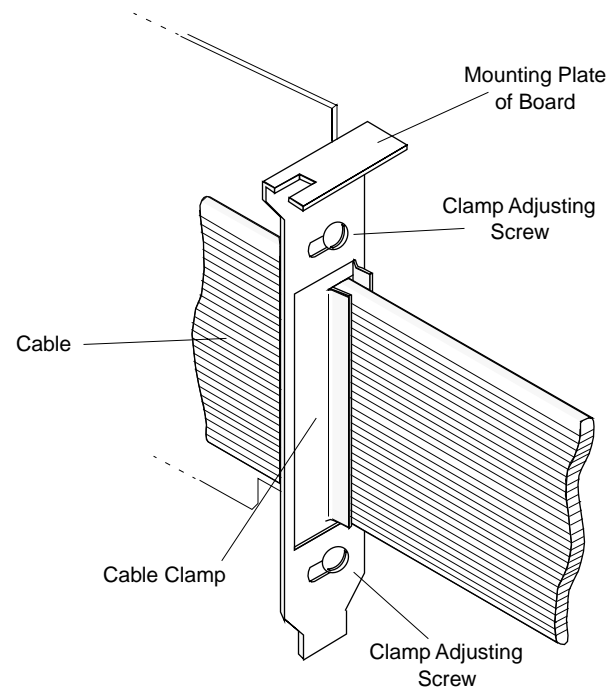

Figure 3-6. Cable Clamp Securing Single Cable

Installing Cable Shielding

To shield cabling for your PIO-SSR Series board, perform the following steps:

1. With cabling installed and clamped, wrap all cables together with a piece of tape to mark a shield boundary at a point $\frac{1}{2}$ -inch or more away from the inside surface of the mounting plate, as shown in Figure 3-7.

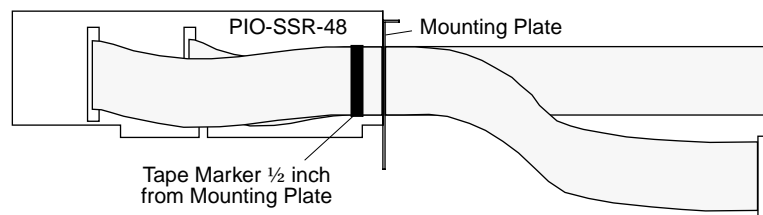

Figure 3-7. Cabling Taped to Show Shield Boundary

2. Remove the two clamp-adjusting screws and the clamp from the board's mounting plate.
3. Unplug the cable connectors from the board, and pull the taped cabling back through the mounting plate until the tape marker is beyond the clamping area.
4. Beginning at the tape marker, cover the cabling with a single piece of jacket to the desired length, as shown in Figure 3-8.

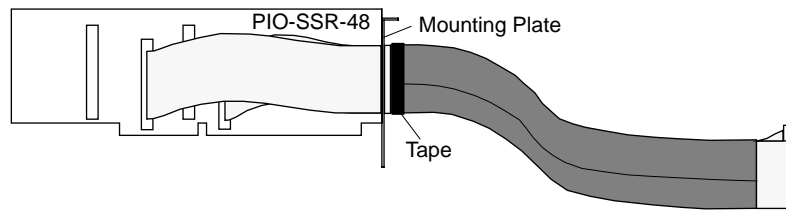

Figure 3-8. Cabling Wrapped with Jacket to Tape Boundary

5. Remove tape from cabling, and use scissors to cut $\frac{1}{2}$ -inch flaps in the jacket on both sides of cable, as shown in Figure 3-9.

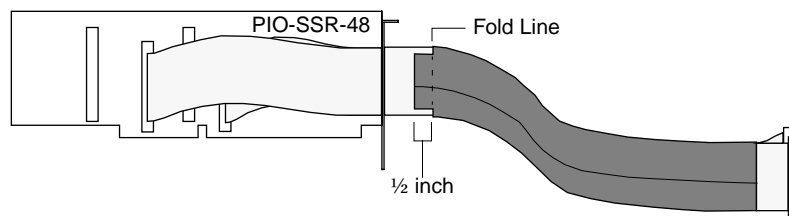

Figure 3-9. Jacket Trimmed with Scissors to Make 1/2-Inch Flaps

6. Fold the flaps back on both sides of the cabling to expose the shield surface, as shown in Figure 3-10.

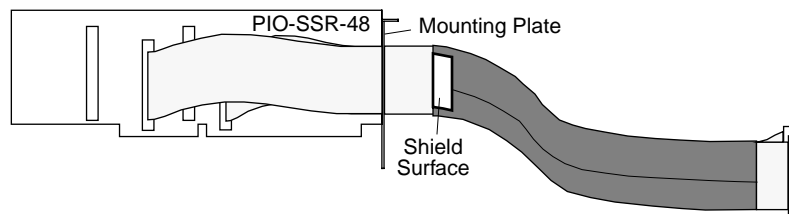

Figure 3-10. Jacket with Flaps Folded Back to Expose Shield Surface

7. Slide cabling back through the mounting plate and plug the cable connectors back into the board, placing shield surface directly in line with mounting-plate clamp, as shown in Figure 3-11.

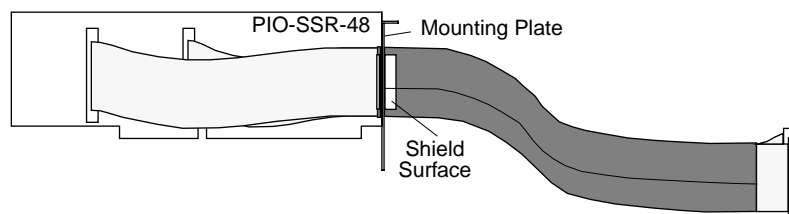

Figure 3-11. Cabling Reconnected, Placing Shield Surface in Line with Clamp

8. Re-install the clamp and clamp-adjusting screws so that the clamp holds the cabling firmly in place while bearing firmly on the shield surface of the jacket flap, as shown in Figure 3-12.

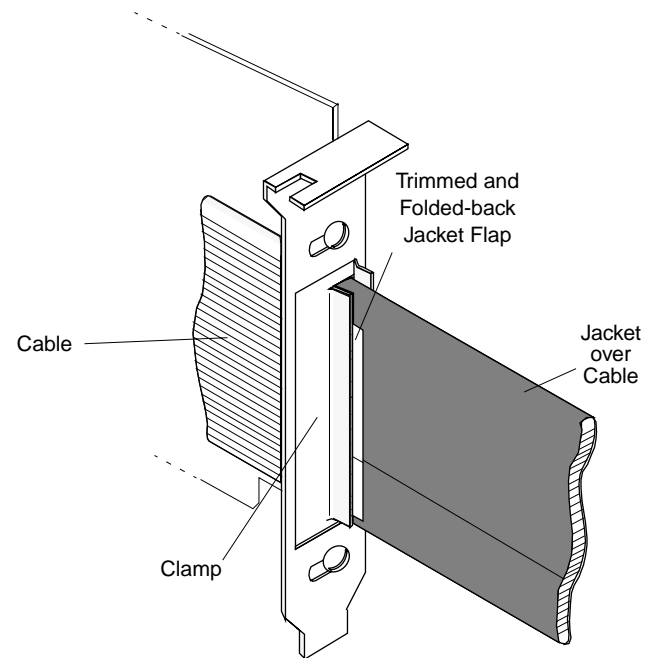

Figure 3-12. Detail of Clamped Cable Showing Installed Jacket

Note: This shielding procedure assures CE Mark compliance (refer to Appendix C for more information).

Installing a Board

Caution: Installing or removing a board while power is ON can damage your computer.

Use the following steps to install a PIO-SSR Series board in an expansion slot of your computer:

1. Turn off power to the computer and all attached equipment.
2. Remove the computer chassis cover.
3. Select an unoccupied expansion slot in the rear panel, and remove the corresponding dummy mounting plate.
4. Ensure the settings of the base-address switch and the IRQ jumper match the settings shown in the configuration utility.
5. Insert and secure the board in the selected expansion slot, feeding any cable ends through the rear panel of the computer as you insert the board.
6. Replace the computer cover.

You can use the AIO Panel (Section 5) to check board operation.

You are now ready to make I/O connections. Refer to Section 4 for descriptions of I/O accessories and connections for a PIO-SSR Series board.

Configuring DriverLINX

After you have successfully installed the PIO-SSR board in your computer, start Windows to install DriverLINX. For detailed instructions on installing DriverLINX, see the documentation provided on the DriverLINX CD-ROM. Refer to the *DriverLINX Installation and Configuration Guide and Using DriverLINX with Your Hardware—Keithley PIO Series* manuals.

Caution: Be sure to note and follow differences in programming between Windows NT and Windows 95/98 as appropriate for your system.

Run Learn DriverLINX (LearnDL.exe) from the DriverLINX program group to tell DriverLINX how you configured your PIO-SSR board and to verify that everything is properly installed and configured.

1. Start Windows as you normally would and select the Program Manager window. Install DriverLINX if you have not previously done so.
2. Either select the Learn DriverLINX icon created when you installed DriverLINX or enter <drive>:/DRVLNX/LEARNDL in the Command Line edit box. The command line edit box is activated by selecting the Run... option. <drive> is the letter of the hard disk drive where DriverLINX is installed.
3. Immediately after loading Learn DL, the Open DriverLINX DLL dialog box appears. Select the name of the hardware-specific DLL from the list for your PIO-SSR board. The name is an abbreviation of the board's model number.
4. From the main menu bar of Learn DL, select the Device menu and choose Select....
5. Select the Logical Device you wish to configure and then click on the OK button (return).
6. Again select the Device menu and then choose the Configure... option to display the Device Configuration Dialog Box.

7. From the Model list, select the model name for the PIO-SSR board you are configuring.
8. If the value displayed in the Address edit box is not correct, type the correct value into the box. You may enter the address in decimal or hexadecimal using the c-notation for hex (that is, 768 decimal = 0x300 hexadecimal).
9. Choose the correct options for the Analog, Digital, and Counter/Timer Sections by first clicking on the appropriate radio button in the middle of the dialog box and then completing the group of dialog fields in the lower third of the dialog box. Be sure to click on both the Input and Output radio buttons for the Analog and Digital groups to see all the dialog fields.
10. After you have made your selections, save the configuration parameters by clicking on the OK button.
11. Repeat the preceding steps, starting at step 5, for each Logical Device you want to configure.

4

Cabling and Wiring

This section describes the cabling and wiring required for attaching accessories and field devices to the I/O connectors of your PIO-SSR Series board. The board contains one I/O connector for each group of 24 channels; thus, the PIO-SSR-24 contains one I/O connector, the PIO-SSR-48 contains two I/O connectors, and the PIO-SSR-120 contains five I/O connectors. Pin assignments for an I/O connector are shown in Appendix B.

Caution: To avoid electrical damage, turn off power to the computer and any accessories before making connections to a PIO-SSR Series board.

Shorting any output of a PIO-SSR Series board to +5V or ground can damage the board.

Connecting an STP-50

An STP-50 connects to an I/O connector of a PIO-SSR Series board as shown in Figure 4-1.

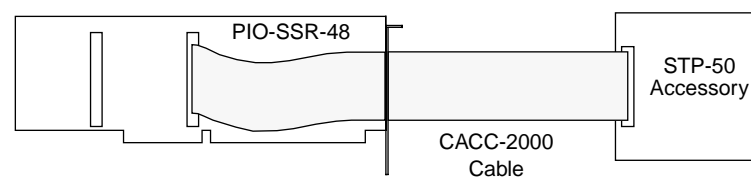

Figure 4-1. Connecting an STP-50 to a PIO-SSR Series Board

Two STP-50 accessories connect to I/O connectors of a PIO-SSR Series board as shown in Figure 4-2.

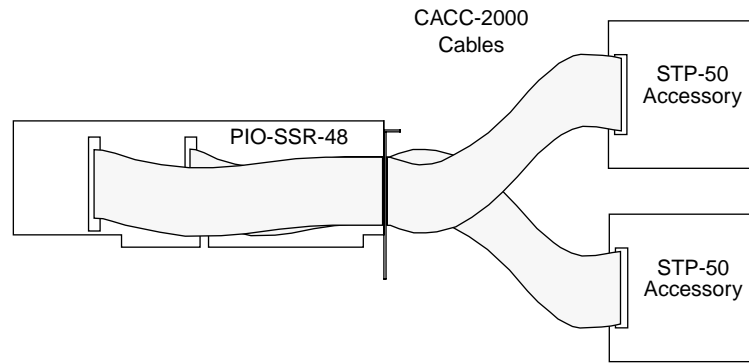

Figure 4-2. Connecting Two STP-50s to a PIO-SSR Series Board

Connecting a PB-24 or PB-24SM

A PB-24 or PB-24SM connects to an I/O connector of a PIO-SSR Series board as shown in Figure 4-3. Refer to Appendix B for pin assignments versus relay connections.

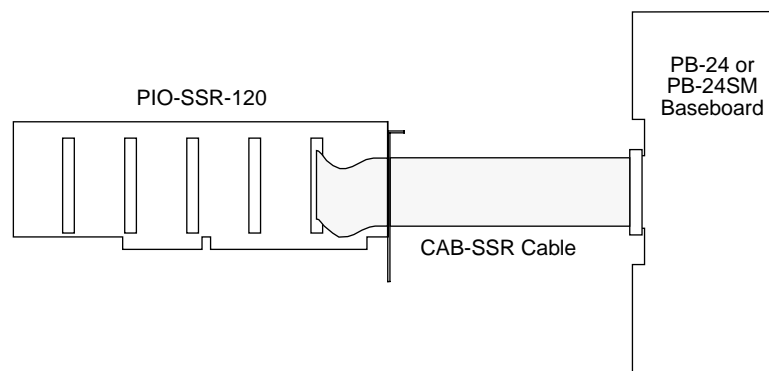

Figure 4-3. Connecting a PB-24 or PB-24SM to a PIO-SSR Series Board

You can connect two or more PB-24 or P-24SM baseboards to I/O connectors of a PIO-SSR Series board as shown in Figure 4-4.

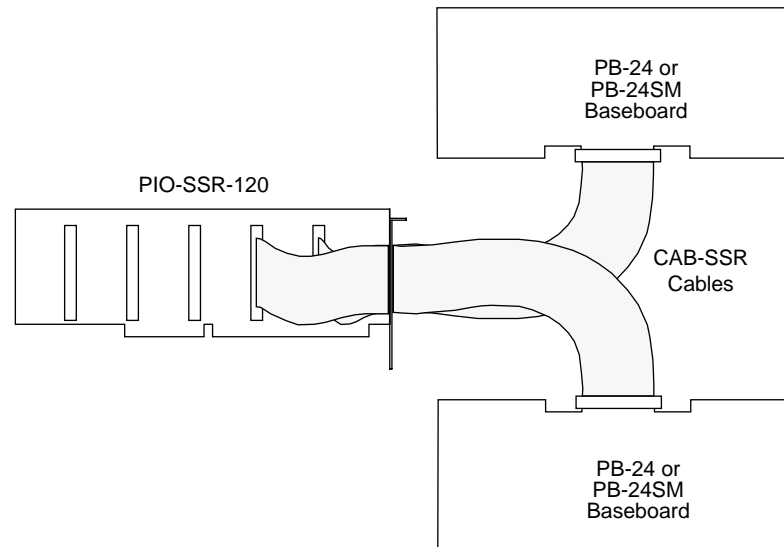

Figure 4-4. Connecting Two PB-24 or PB-24SM Accessories to a PIO-SSR Series Board

Monitoring Contact Closure at an Input

An onboard $10\text{k}\Omega$ pull-up resistor connected between each channel and the +5V serves to prevent floating input when contact is open and gives CMOS compatibility for TTL signals. Figure 4-5 shows how this resistor makes an input of a PIO-SSR Series board an effective circuit for monitoring contact closure.

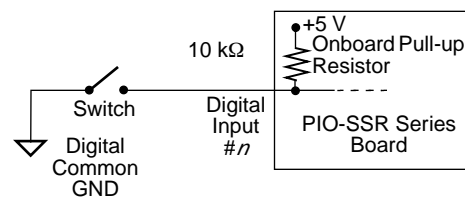

Figure 4-5. Contact-Closure Monitoring at an Input of a PIO-SSR Series Board

Eliminating Contact Bounce

While you can eliminate contact bounce through your application program, you can also insert a bounce circuit between the contacts and the input of your PIO-SSR Series board. Figure 4-6 shows a typical bounce circuit.

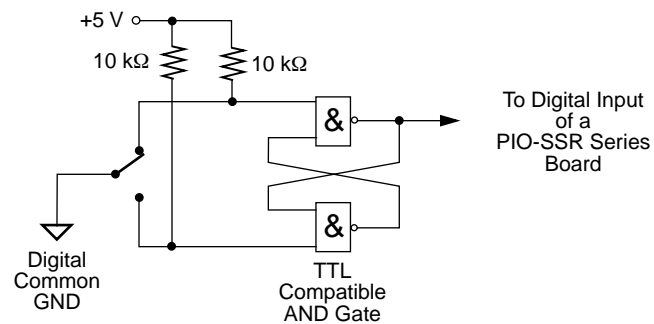

Figure 4-6. Bounce Circuit for an Input of a PIO-SSR Series Board

Boosting Relay Drive Current

PIO-SSR Series boards can drive relays other than the standard solid-state relays. The maximum output current for each channel of a PIO-SSR Series board is 24mA at 5V. If your relay requires more than 24mA or more than 5V, you can boost the drive current and/or voltage for relay control using the circuit shown in Figure 4-7.

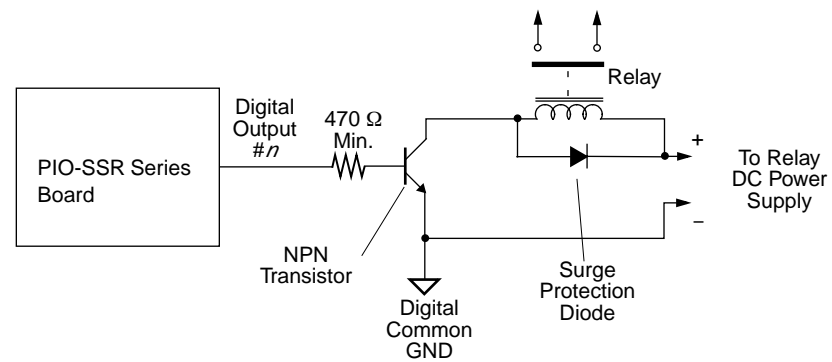

Figure 4-7. NPN Transistor Relay Control for an Output of a PIO-SSR Series Board

For drive-current requirements between 15mA and 100mA, select an NPN transistor with appropriate current capacity. The power transistor must be rated for the required supply voltage and must have a collector current rating no higher than 0.5A. If higher current is needed, substitute a Darlington NPN transistor.

5

Testing Your Board

You can use DriverLINX to verify board operation:

1. To physically initialize the PIO-SSR, select Device/Initialize from the main menu in Learn DriverLINX.
2. The first time the PIO-SSR is initialized, or after a configuration change, DriverLINX runs a diagnostic program to verify the operation and accuracy of the configuration settings.

After you install the PIO-SSR board and configure DriverLINX for the desired PIO-SSR configuration, you can attach an accessory board and wire the appropriate signals to the board. Before writing your application program, you can test the functions of the PIO-SSR board using the DriverLINX AIO Panel test program.

I/O Bit Tests

General Information

1. Start the AIO Panel as follows:
 - a. In the **Start** menu, click **Programs**.
 - b. Find the **DriverLINX ▶ Test Panels** folder, under which you should find the **AIO Panel** entry.

- c. Click on the **AIO Panel** entry. The **Analog I/O Panel** should appear, similar to the example in Figure 5-1. (If you have other DriverLINX devices installed in addition to the digital input/output card you are testing, they will also be listed. In that case, select the desired digital I/O card and the proper device number before proceeding.)

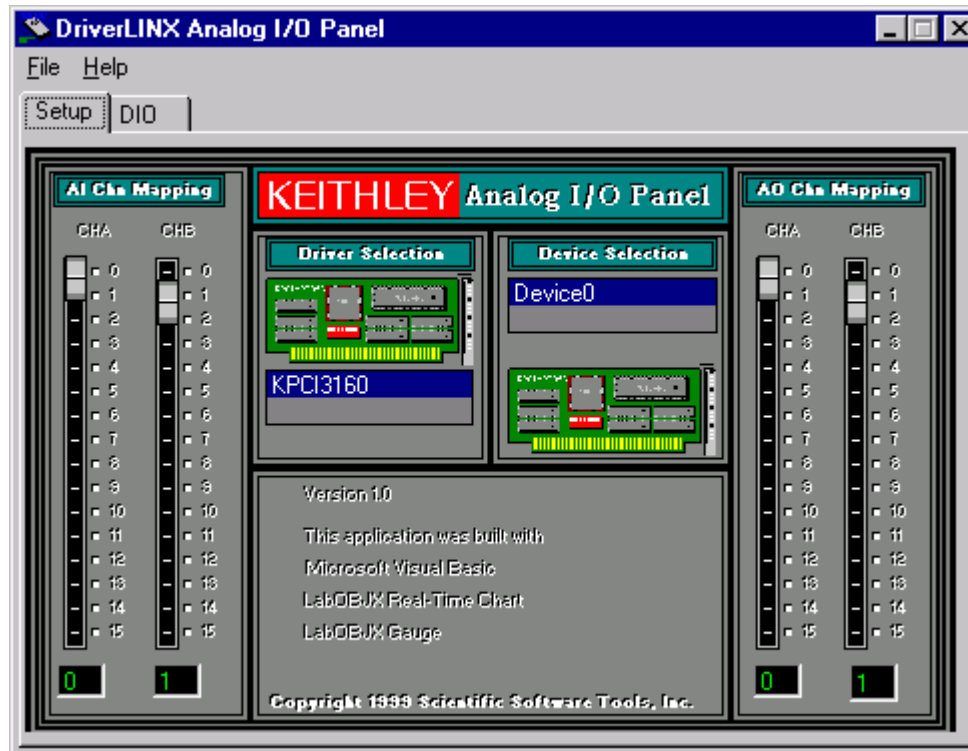

Figure 5-1. An AIO Panel example

Note: The “Driver Selection” column will show the actual DriverLINX driver(s) you have installed.

2. On the AIO Control Panel, click the DIO tab.

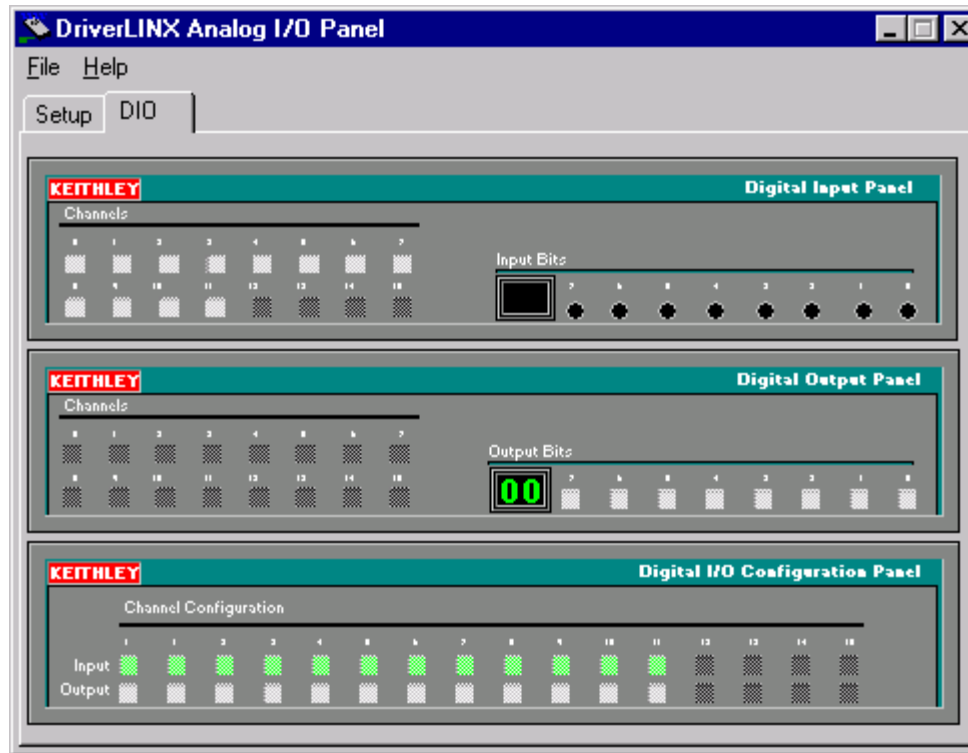

Figure 5-2. DIO channel tab example

Note: The on-screen digital I/O controller works as follows:

- Channels 0 to 15 refer to the 8-bit general-purpose registers of your digital input-output card. (Depending on which card is used, the number of valid 8-bit registers will vary.) Bits displayed on the **Digital Input Panel** and the **Digital Output Panel** are numbered 0-7 for every channel. Refer elsewhere in this manual for a description of the available ports and their direction.
- Invalid channels and settings appear as dark gray squares. For example:
 - Non-existent channels always appear as dark gray squares.
 - Channels configured as inputs will appear as dark gray squares on the output panel.
- Valid channels and settings appear as white squares when OFF and green squares when ON. (When the manual is printed in black and white, valid channels and settings appear as white squares when OFF and as light gray squares when ON.)
- The two-digit numeric displays under **Input Bits** and **Output Bits** show the hexadecimal values of the adjacent bit patterns.
- To configure a valid channel either for input or output, use the **Digital Channel Configuration Panel**. Click on either the **Input** or **Output** square below the channel number. Note: this selection will be disabled for channels which are fixed as input or output by hardware design.
- To turn ON output-channel bits, use the **Digital Output Panel**. First select the channel number of the bits to be turned on by clicking on the appropriate square under **Channels**. Then, turn ON a bit by clicking the appropriate square under **Output Bits**. Turn OFF a bit in the same way.
- To read an input-channel bit, use the **Digital Input Panel**. First select the channel number to be checked by clicking the appropriate square under **Channels**. Then, read the numbered bit under **Input Bits**. OFF input bits appear as black dots and ON input bits appear as green dots. (When the manual is printed in black and white, OFF input bits appear as black dots and ON input bits appear as light gray dots.)

3. Under **Digital I/O Configuration Panel**, configure channels as shown in Figure 5-3. (Actual channels available will vary according to your hardware.)

KEITHLEY		Digital I/O Configuration Panel															
Channel Configuration																	
		0	1	2	3	4	5	6	7	8	9	10	11	12	13	14	15
Input	<input type="checkbox"/>	<input checked="" type="checkbox"/>	<input checked="" type="checkbox"/>	<input checked="" type="checkbox"/>	<input checked="" type="checkbox"/>	<input checked="" type="checkbox"/>	<input checked="" type="checkbox"/>	<input checked="" type="checkbox"/>	<input checked="" type="checkbox"/>	<input checked="" type="checkbox"/>	<input checked="" type="checkbox"/>	<input checked="" type="checkbox"/>	<input checked="" type="checkbox"/>	<input type="checkbox"/>	<input type="checkbox"/>	<input type="checkbox"/>	<input type="checkbox"/>
Output	<input checked="" type="checkbox"/>	<input type="checkbox"/>	<input type="checkbox"/>	<input type="checkbox"/>	<input type="checkbox"/>	<input type="checkbox"/>	<input type="checkbox"/>	<input type="checkbox"/>	<input type="checkbox"/>	<input type="checkbox"/>	<input type="checkbox"/>	<input type="checkbox"/>	<input type="checkbox"/>	<input checked="" type="checkbox"/>	<input checked="" type="checkbox"/>	<input checked="" type="checkbox"/>	<input checked="" type="checkbox"/>

Figure 5-3. Configuring the digital I/O channels as inputs and outputs

Note: For clarity when the manual is printed in black and white, the control colors in Figure 5-3 and subsequent drawings will be shown as follows:

Illustration	Color on Actual Panel	Function
BLACK	DARK GRAY	Invalid
WHITE	LIGHT GRAY	OFF
GRAY	GREEN	ON

4. In the **Digital Output Panel** under **Channels**, click on a channel (here, channel 0) as shown in Figure 5-4.

KEITHLEY		Digital Output Panel																
Channels																		
		0	1	2	3	4	5	6	7	Output Bits								
	<input checked="" type="checkbox"/>	<input type="checkbox"/>	<input type="checkbox"/>	<input type="checkbox"/>	<input type="checkbox"/>	<input type="checkbox"/>	<input type="checkbox"/>	<input type="checkbox"/>	<input type="checkbox"/>	55	<input type="checkbox"/>	<input checked="" type="checkbox"/>	<input type="checkbox"/>	<input checked="" type="checkbox"/>	<input type="checkbox"/>	<input checked="" type="checkbox"/>	<input type="checkbox"/>	<input checked="" type="checkbox"/>
	<input type="checkbox"/>	<input type="checkbox"/>	<input type="checkbox"/>	<input type="checkbox"/>	<input type="checkbox"/>	<input type="checkbox"/>	<input type="checkbox"/>	<input type="checkbox"/>	<input type="checkbox"/>		<input type="checkbox"/>	<input type="checkbox"/>	<input type="checkbox"/>	<input type="checkbox"/>	<input type="checkbox"/>	<input type="checkbox"/>	<input type="checkbox"/>	<input type="checkbox"/>

Figure 5-4. Configuring channel 0 for output bit pattern A

5. In the **Digital Output Panel** under **Output Bits**, set the bits of the channel as desired as shown in Figure 5-4. (Click on each bit position to turn it ON or OFF.)
6. In the **Digital Input Panel** under **Channels**, click on a channel to select it and display the logical state of its input lines.

Output Set Test

The output set test checks whether logic levels measured at all output pins agree with output bit patterns set by software, using a DriverLINX graphical interface (AIO Panel).

Note: This test is performed without user circuits being connected to the outputs.

Perform the output set test as follows:

1. Ready the following equipment:
 - A digital voltmeter (DVM) or a digital multimeter (DMM) set to measure voltages, or a logic probe capable of reading TTL logic levels.
 - A suitable accessory and cable for the board being tested.
2. Turn OFF the host computer.
3. Connect the cable and accessory to your board.
4. Turn ON the host computer and boot Windows 95/98/NT.
5. Click the Windows 95/98/NT **Start** tab.
6. Start the AIO Panel as follows:
 - a. In the **Start** menu, click **Programs**.
 - b. Find the **DriverLINX ▶ Test Panels** folder, under which you should find the **AIO Panel** entry.

- c. Click on the **AIO Panel** entry. The **Analog I/O Panel** should appear, similar to the example in Figure 5-5. (If you have other DriverLINX devices installed in addition to the digital input/output card you are testing, they will also be listed. In that case, select the desired digital I/O card and the proper device number before proceeding.)

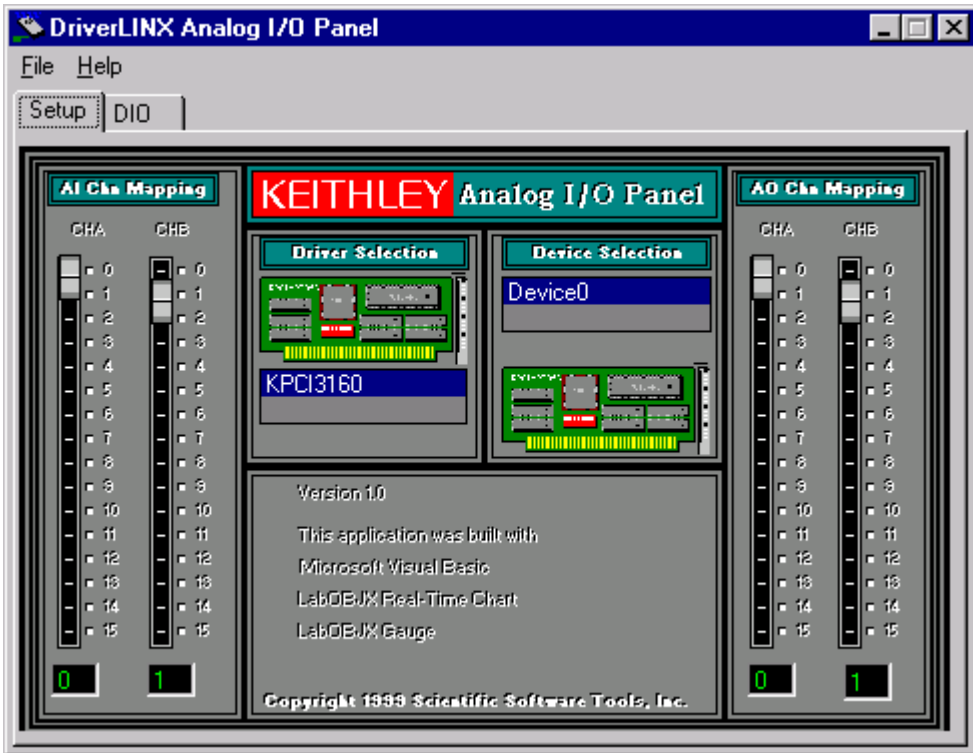

Figure 5-5. An AIO Panel example

7. On the **AIO Panel**, click the **DIO** tab.

Note: To read an input-channel bit, use the **Digital Input Panel**. First, select the channel number to be checked by clicking the appropriate square under **Channels**. Then, read the numbered bit under **Input Bits**. OFF input bits appear as black dots and ON input bits appear as green dots. (When the manual is printed in black and white, OFF input bits appear as black dots and ON input bits appear as light gray dots.) Further information about this panel, how to make changes, and how to interpret displays, is given in “I/O Bit Tests” of this section.

- Under **Digital I/O Configuration Panel**, configure the output channels to be tested as shown in Figure 5-6. (Actual output channels available will vary according to your hardware.)

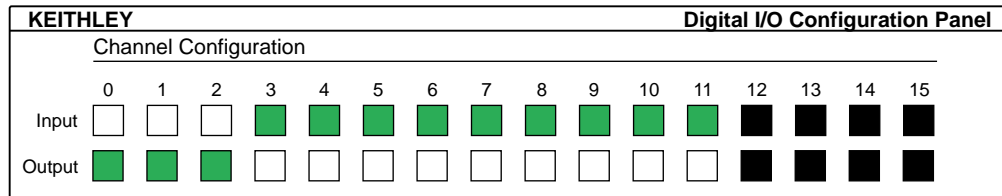

Figure 5-6. Configuring the digital I/O channels as inputs and outputs

Note: In Figure 5-6 and subsequent drawings of digital I/O controller panels, the squares below invalid channels are colored black instead of dark gray—for clarity when the manual is printed in black and white.

- In the **Digital Output Panel** under **Channels**, click on an output channel (channel 0 in this example) as shown in Figure 5-7.

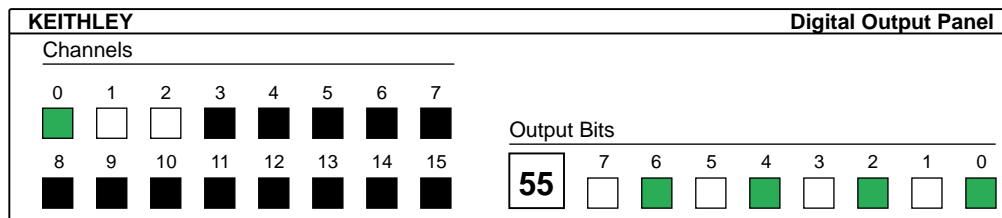

Figure 5-7. Configuring channel 0 for output bit pattern A

- In the **Digital Output Panel** under **Output Bits**, set the bits of channel 0 for bit pattern A as shown in Figure 5-7.
- Measure the voltage between signal ground and each bit of the output port with a DMM or DVM. Make measurements at the cabled mating connector of your accessory.

- Each bit set to ON in the **AIO Panel** should output a logic-high signal at the corresponding I/O terminal, reading typically about 4 volts (minimum of 2.2 volts) at a DMM/DVM. Each bit set to OFF in the **AIO Panel** should output a logic-low signal at the corresponding I/O terminal, reading typically about 0 volts (maximum of 0.8 volts) at a DMM/DVM. Do one of the following:

Note: The typical values shown are valid for boards with TTL compatible outputs. For boards with relay outputs (REL-16, PDISO-8, and PIO-32) the output will be a relay contact closure. For boards with open collector outputs (PIO-HV) use a pull up resistor to an appropriate voltage to detect output state. Refer to the hardware description in this user's guide for more details on the output's electrical specification.

- If the bit patterns set on the **AIO Panel** do not agree with the logic levels measured at the I/O terminals, the board is not functioning properly. Stop here, and determine why.
 - If the bit patterns set on the **AIO Panel** agree with the logic levels measured at the I/O terminals, then repeat steps 9, 10, and 11 for remaining output channels.
- In the **Digital Output Panel** under **Channels**, click on the output channel to test (channel 0 in this example) as shown in Figure 5-8.

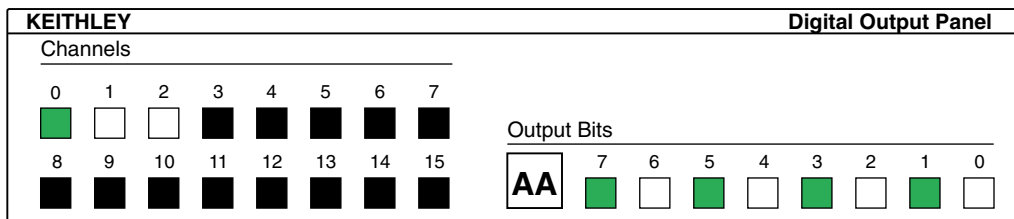

Figure 5-8. Configuring channel 0 for output bit pattern B

- In the **Digital Output Panel** under **Output Bits**, set the bits of channel 0 for bit pattern B as shown in Figure 5-8.
- Measure the voltage between signal ground and each bit of the output port with a DMM or DVM. Make measurements at the STA-50 terminals or the cabled mating connector that is connected to the selected CONN-3160-D1 50-pin connector.

16. Again, each bit set to ON in the **AIO Panel** should output a logic-high signal at the corresponding I/O terminal, reading typically about 4 volts (minimum of 2.2 volts) at a DMM/DVM. Each bit set to OFF in the **AIO Panel** should output a logic-low signal at the corresponding I/O terminal, reading typically about 0 volts (maximum of 0.8 volts) at a DMM/DVM.

Note: The typical values shown are valid for boards with TTL compatible outputs. For boards with relay outputs (REL-16, PDISO-8, and PIO-32) the output will be a relay contact closure. For boards with open collector outputs (PIO-HV) use a pull up resistor to an appropriate voltage to detect output state. Refer to the hardware description in this user's guide for more details on the output's electrical specification.

- If the bit patterns set on the **AIO Panel** do not agree with the logic levels measured at the I/O terminals, the board is not functioning properly. Stop here, and determine why.
 - If the bit patterns set on the **AIO Panel** do agree with the logic levels measured at the I/O terminals, and you have performed an output set test for all ports, the board is functioning properly.
17. Repeat steps 13, 14, and 15 for additional output channels.

Input Read Test

A similar test of input circuitry can be performed by applying an input signal of suitable type to each input line and verifying that the appropriate input indicator changes state. Refer to the hardware description in this user's guide for more details on the input's electrical specifications.

6

Programming Options

Selecting an Application Programming Interface

The PIO Series supports two different device driver interfaces to best match your programming needs. The supported driver interfaces are

- **DriverLINX** — An interface that is hardware and operating system independent and supports multitasking, multi-threading applications.
- **Direct I/O** — An interface that is operating system independent and supports single-tasking, single-threaded access to an Intel 8255-like function call interface.

DriverLINX Interface

For maximum portability and versatility, it is recommended that the DriverLINX interface be used. The DriverLINX interface has the following advantages:

- **Hardware independence** — DriverLINX supports ISA, PCMCIA, and PCI digital I/O boards with a common interface as well as digital ports on analog I/O and counter/timer boards.
- **Operating system independence** — DriverLINX supports Windows 95/98 and Windows NT with a common interface.
- **Shared hardware access** — DriverLINX allows multiple processes or threads to cooperatively share hardware resources.
- **Multitasking, multi-threading support** — DriverLINX provides the synchronization and coordination for multitasking, multi-threading applications to safely access shared hardware resources.

- **Portability** — DriverLINX supports older and newer hardware with a common interface for 16- and 32-bit applications on Windows 95/98 and Windows NT.
- **Versatility** — DriverLINX supports a wide variety of programming styles and languages including C/C++, Visual Basic, Delphi, and LabVIEW.
- **Background I/O** — DriverLINX supports background I/O using interrupts or other techniques so your application can overlap processing and data acquisition.
- **Full hardware support** — DriverLINX supports all the hardware's features.

The DriverLINX interface has a few disadvantages compared to the alternative interfaces:

- **Software modifications** — Existing applications will require rewriting to use DriverLINX.
- **No direct hardware access** — Before Windows NT, Microsoft discouraged, but nevertheless allowed, direct application program access to hardware.
- **Speed of single-value I/O** — Applications, especially those ported from DOS, that depend on rapid software polling of I/O ports will notice that the operating system time cost for multitasking, multi-threading synchronization is higher than direct hardware access.

While writing your application to use a multi-product, portable application programming interface is the best long-term solution, you should consider the alternative API only for special purpose or short-term needs.

Direct I/O Application Programming Interface

The Direct I/O interface uses the methods of an ActiveX Automation object to access the PIO hardware. This interface has the following advantages:

- **Operating system independence** — Both Windows 95/98 and Windows NT support this interface.
- **Intel 8255 emulation** — This interface uses the I/O address map and programming protocols of Intel's 8255 chip.
- **Fast hardware access** — This interface provides the fastest access to the hardware registers of the two interfaces.
- **Versatility** — Most Windows compilers and scripting languages support ActiveX Automation objects.
- **Native hardware register access** — For special-purpose applications, this interface also supports product-specific access to the hardware registers.
- **Speed of single-value I/O** — The I/O performance of this interface is the fastest of the two interfaces when using early binding to the interface.

The Direct I/O interface also has disadvantages:

- **Incompatible with DriverLINX** — Applications cannot use this interface with DriverLINX for the PIO Series either in the same or another application.
- **32-bit only interface** — 16-bit applications cannot use this interface.
- **Non-exclusive hardware access** — This interface does not synchronize or coordinate hardware access among threads or processes.
- **8-bit I/O only** — The Intel 8255-based methods only support 8-bit hardware access.
- **Supports subset of hardware features** — This interface does not support using interrupts.
- **ActiveX Interface** — Using Automation objects in some C++ compilers is more difficult than in Visual Basic.

Installing the Direct I/O Driver

The normal DriverLINX installation automatically installs the Direct I/O Driver. This driver is a registered ActiveX object that resides in KISAPIO.DLL.

This driver requires that you install the DriverLINX kernel drivers as it uses their services. On Windows NT, the kernel driver is KMBPIO.SYS. On Windows 95/98, it is KMBPIO.VXD. Follow the normal DriverLINX installation and configuration procedures to install these kernel drivers.

Configuring the Direct I/O Driver

The Direct I/O Driver requires that you configure a DriverLINX Logical Device using the DriverLINX Configuration Panel utility. The Direct I/O driver does not require any separate configuration.

Programming the Direct I/O Interface

The Direct I/O Interface is an ActiveX Automation object hosting one interface. This control is compatible with Microsoft Visual C++ and Visual Basic as well as other ActiveX-hosting languages.

The methods of the control's interface, ISAPIO, access the 8-bit ports of an Intel 8255 chip.

ISAPIO Intel 8255 Interface

The following syntax descriptions are shown in C/C++. For Visual Basic, use the Object Browser to see the VB syntax (see the next segment, *Using the Direct I/O Driver in Visual Basic*).

- **HRESULT Open Device(long Device);**
Opens a PIO device.
Device is the DriverLINX Logical Device number of the PIO board to open.

- **HRESULT CloseDevice();**
Closes a previously opened PIO device.
The number of CloseDevice calls must match the number of OpenDevice calls.
- **HRESULT Read(short Offset, unsigned char * Result);**
Reads an 8-bit value from the PIO board.
Offset is the value of the register to read relative to the base I/O address. Result is the value read from the register.
- **HRESULT Write(short Offset, unsigned char Value);**
Writes an 8-bit value to the PIO board.
Offset is the value of the register to write relative to the base I/O address. Value is the output to write to the register.
- **HRESULT OpenCount(long *Count);**
Returns the number of times a client has called OpenDevice for this Logical Device. Count is the address of the value for the result.
- **HRESULT Device(long *LogicalDevice);**
Returns the Logical Device number if the device is open. Otherwise it returns -1. LogicalDevice is the address of the value for the result.

Using the Direct I/O Driver in Visual Basic

The following instructions are for Version 5 of Microsoft Visual Basic. If you have a different version, consult the Visual Basic documentation.

1. From VB's Project menu, select References...
2. Scroll through the Available References, looking for Keithley ISA PIO Direct I/O Library.
3. Check Keithley ISA PIO Direct I/O Library and then click OK.
4. From VB's View menu, select Object Browser to display a list of libraries.
5. Search for KISAPIOLib.
6. The Object Browser shows the VB syntax for the KISAPIO class.

Creating a Simple Visual Basic Application

1. Create a Visual Basic form.
2. Add the following source code to declare, open, close, read, and write a PIO device:

```
Option Explicit
Dim PIO As New KISAPIO

Private Sub Close_Click()
    PIO.CloseDevice
End Sub

Private Sub btOpen_Click()
    PIO.OpenDevice (Val(tbDevice))
End Sub

Private Sub btRead_Click()
    tbValue=Hex(PIO.Read(Val(tbAddr)))
End Sub

Private Sub btWrite_Click_()
    Dim v As Byte

    v=Val(tbValue)
    PIO.Write Val(tbAddr), v
End Sub
```

Register-Level Programming

Note: Ignore this section if you are using the Function Call Driver from your ASO-PIO software package.

If your application goes beyond the capabilities of the software included with your board, you must develop your own programming for control of I/O functions. You can program the I/O functions because each group of 24 digital I/O channels on your PIO-SSR Series board emulates Mode 0 operation of an Intel 8255A Programmable Peripheral Interface (PPI) integrated circuit. Mode 0 is one of the following three modes of operation available with an 8255A:

- **Mode 0** - Basic I/O; all ports are I/O ports.
- **Mode 1** - Strobed I/O; part of Port C controls data transfer.
- **Mode 2** - Bidirectional I/O on Port A only; part of Port C controls data transfer.

Note: For a complete description of the PPI operating modes, refer to an Intel 8255A data sheet.

Your PIO-SSR Series board emulates Mode 0 only. Modes 1 and 2 are not supported.

PIO-SSR Series boards contain 24-channel groups, as follows:

- A PIO-SSR-24 contains one group.
- A PIO-SSR-48 contains two groups.
- A PIO-SSR-120 contains five groups.

The 24 digital I/O channels of a group include three 8-channel ports, as follows: Port A, Port B, and Port C. The following section shows the I/O addressing of these ports.

I/O Address Maps

The following four tables (Table 6-1, 6-2, 6-3, and 6-4) show the I/O address maps for the three models of PIO-SSR Series boards.

Table 6-1. I/O Address Map for a PIO-SSR-24

Base I/O Address	Write	Read
+0h	J1-Port A	J1-Port A
+1h	J1-Port B	J1-Port B
+2h	J1-Port C	J1-Port C
+3h	J1-Control Word	—
+4h	IRQ Control 1	IRQ Status 1

Table 6-2. I/O Address Map for a PIO-SSR-48

Base I/O Address	Write	Read
+0h	J1-Port A	J1-Port A
+1h	J1-Port B	J1-Port B
+2h	J1-Port C	J1-Port C
+3h	J1-Control Word	—
+4h	J2-Port A	J2-Port A
+5h	J2-Port B	J2-Port B
+6h	J2-Port C	J2-Port C
+7h	J2-Control Word	—
+8h	IRQ Control 1	IRQ Status 1

Table 6-3. I/O Address Map for a PIO-SSR-120

Base I/O Address	Write	Read
+0h	J1-Port A	J1-Port A
+1h	J1-Port B	J1-Port B
+2h	J1-Port C	J1-Port C
+3h	J1-Control Word	—
+4h	J2-Port A	J2-Port A
+5h	J2-Port B	J2-Port B
+6h	J3-Port C	J2-Port C
+7h	J2-Control Word	—
+8h	J3-Port A	J3-Port A
+9h	J3-Port B	J3-Port B
+Ah	J3-Port C	J3-Port C
+Bh	J3-Control Word	—
+Ch	J4-Port A	J4-Port A
+Dh	J4-Port B	J4-Port B
+Eh	J4-Port C	J4-Port C
+Fh	J4-Control Word	—
+10h	J5-Port A	J5-Port A
+11h	J5-Port B	J5-Port B
+12h	J5-Port C	J5-Port C
+13h	J5-Control Word	—
+14h	IRQ Control 1	IRQ Status 1
+15h	IRQ Control 2	IRQ Status 2

Note that in the preceding tables each group of ports has its own Control Word. The Control Word for a particular group determines whether each port in that group is functioning as an input or an output. Control Words are described in the following section.

Control Word Register

Before using your board, you must set the Control Word for each group to configure the ports as inputs or outputs. The Control Word for each group is contained in an 8-bit, write-only, Control Word register for that group. Table 6-4 shows the bit assignments of a Control Word register.

Table 6-4. Bit Assignments for a Control Word Register

Bit #	Value
7	1
6	0
5	0
4	Port A: 1 = input; 0 = output
3	Port C (upper four bits): 1 = input; 0 = output
2	0
1	Port B: 1 = input; 0 = output
0	Port C (lower four bits): 1 = input; 0 = output

Note that you can set Port A, Port B, and the upper and lower four bits of Port C independently. As an example, the following register bits show a Control Word of 93h. This Control Word sets Ports A, B, and C-Lower as inputs while setting Port C-Upper as an output.

Bit 7	Bit 6	Bit 5	Bit 4	Bit 3	Bit 2	Bit 1	Bit 0
1	0	0	1	0	0	1	1

IRQ Control Registers 1 and 2

Figure 6-1 shows a simplified IRQ circuit for one or more groups of 24 channels.

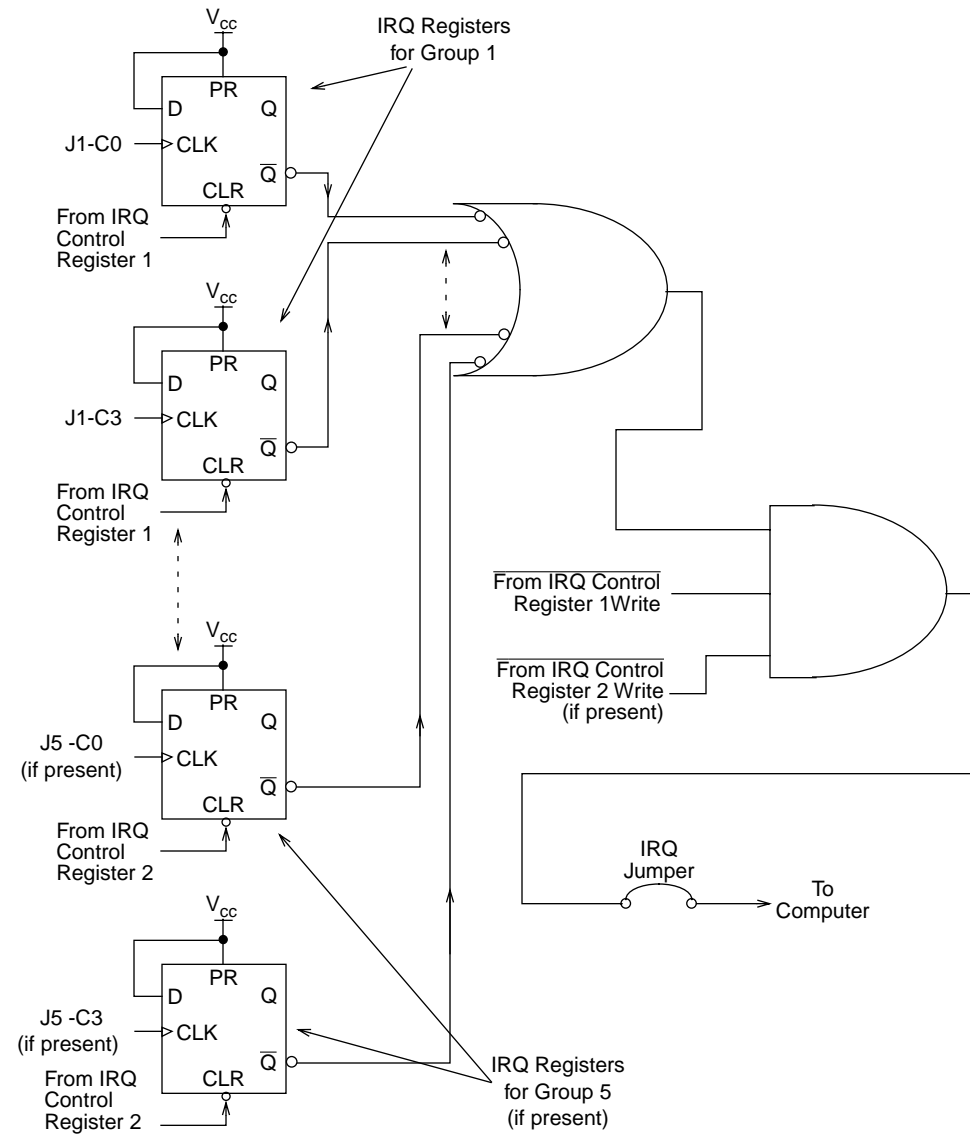

Figure 6-1. Block Diagram of IRQ Circuit

A low-to-high transition at the input of Port C channel 0 (C0) or Port C channel 3 (C3) generates an IRQ signal that is stored in the IRQ register for that channel. You can enable an IRQ register for a particular channel by writing 0 to the bit for that channel in the IRQ Control register, or you can disable and clear that IRQ register by writing 1 to that same bit. The IRQ Control registers are write-only. The I/O addresses of the IRQ Control register bits for each group are listed in Tables 6-5, 6-6, and 6-7.

Table 6-5. Addresses of IRQ Control Register Bits for a PIO-SSR-24

Input Channel	Bit #	I/O Address
J1-C0	0	Base address +4h
J1-C3	1	Base address +4h

Table 6-6. Addresses of IRQ Control Register Bits for a PIO-SSR-48

Input Channel	Bit #	I/O Address
J1-C0	0	Base address +8h
J1-C3	1	Base address +8h
J2-C0	2	Base address +8h
J2-C3	3	Base address +8h

Table 6-7. Addresses of IRQ Control Register Bits for a PIO-SSR-120

Input Channel	Bit #	I/O Address
J1-C0	0	Base address +14h
J1-C3	1	Base address +14h
J2-C0	2	Base address +14h
J2-C3	3	Base address +14h
J3-C0	4	Base address +14h
J3-C3	5	Base address +14h
J4-C0	6	Base address +14h
J4-C3	7	Base address +14h
J5-C0	0	Base address +15h
J5-C3	1	Base address +15h

IRQ Status Registers 1 and 2

The IRQ Status registers are read-only. The I/O addresses of the IRQ Status register bits for the C0 and C3 channels of each group are the same as those shown for the IRQ Control register.

A 1 for a particular IRQ Status register bit indicates the issue of an IRQ signal by the corresponding input channel. This bit remains a 1 until cleared and disabled.

The following two lines of BASIC code are an example of commands to read the settings of all IRQ Status register bits in a PIO-SSR-120 whose base I/O address is 300h.

```
ST1 = INP (&H314)    'Read IRQ status of J1 to J4
                        'groups
ST2 = INP (&H315)    'Read IRQ status of J5 group
```

When you power up your computer, your PIO-SSR Series board sets the IRQ signals of all C0 and C3 channels to 1, disabling the IRQ Control registers. Before you can use the interrupts on a PIO-SSR-120 with a base I/O address of 300h, you must issue the following commands to enable the IRQ Control registers:

```
OUT &H314, &HFF 'Disable/clear Group 1 to 4 IRQs
OUT &H315, &HFF 'Disable/clear Group 5 IRQs

OUT &H314, &Hxx 'Where xx is 0 (binary) for each
                'interrupt to be used
OUT &H315, &Hxx 'Where xx is 0 (binary) for each
                'interrupt to be used
```

After you enable the IRQ Control registers and position the IRQ jumper at the desired level, your PIO-SSR Series board can issue IRQs to the computer. You can then determine which channels have issued IRQs by reading the IRQ Status Registers 1 and 2. When the interrupts are complete, use the above commands to disable, clear, and re-enable the IRQ Control registers.

Note that if you are using a PIO-SSR-120, you need two write commands to disable/clear the two IRQ Control registers, because the board is using the 8-bit data bus. As Figure 6-1 on page 6-11 shows, the write signals from IRQ Control Registers 1 and 2 plus the output of the OR gate are connected to the AND gate. When at least one IRQ is indicated at each IRQ Control register, writing to clear one register causes the issue of an extra IRQ because the second register is not cleared by the first write. To avoid this extra interrupt, Keithley recommends using your interrupt-handler program (shown in the above commands) to disable, clear, and re-enable both IRQ Control registers by checking the settings in your IRQ Status registers before returning to the main program.

7

Troubleshooting

If your PIO-SSR board is not operating properly, use the information in this section to isolate the problem. If the problem appears serious enough to warrant technical support, refer to *Technical Support* for information on how to contact an applications engineer.

Using the DriverLINX Event Viewer

The DriverLINX Event Viewer displays the Windows system event log. Applications and hardware drivers make entries in the system event log to assist in predicting and troubleshooting hardware and software problems.

DriverLINX uses the event log to report problems during driver loading or unexpected system errors. The event log can assist in troubleshooting resource conflicts and DriverLINX configuration errors. If you are having trouble configuring or initializing a Logical Device, check the event log for information from the DriverLINX driver.

Using the DriverLINX Event Viewer, you can view, save, and e-mail DriverLINX event log entries under Windows 95/98 or Windows NT. DriverLINX event log entries can help you or technical support troubleshoot data-acquisition hardware and software problems.

Device Initialization Error Messages

During device initialization, DriverLINX performs a thorough test of all possible subsystems on PIO-SSR boards as well as the computer interface. If DriverLINX detects any problems or unexpected responses, it reports an error message to help isolate the problem. The device initialization error messages fall into three basic categories:

- **Device not found** — Board address does not match hardware setting or conflicts with another board. Verify the board's address settings. Also, don't confuse hexadecimal with decimal addresses in the DriverLINX Device Configuration dialog box.
- **Invalid IRQ level or Invalid DMA level** — Selected level does not match hardware setting, conflicts with another board's IRQ/DMA levels, or is dedicated to the computer's internal functions (COM port, disk drive controller, network adapter, etc.)
- **Hardware does not match configuration** — Operating mode/range switch or jumper setting does not match selection(s) made in the DriverLINX Device Configuration dialog box.

Problem Isolation

If you encounter a problem with a PIO-SSR Series board, use the instructions in this section to isolate the cause of the problem before calling Keithley for technical support.

Identifying Symptoms and Possible Causes

Table 7-1 lists general symptoms and possible solutions for problems with PIO-SSR Series boards. Use the troubleshooting information in Table 7-1 to try to isolate the problem.

Table 7-1. Troubleshooting Information

Symptom	Possible Cause	Possible Solution
Board does not respond	Base address is incorrect or not consistent with what the program is addressing.	Check the base-address-switch setting on the board against the setting shown in the configuration utility. If the base address is set correctly, make sure no other computer device is using any of the I/O locations beginning at the specified base address. If necessary, reconfigure the base address.
	The interrupt level is incorrect or not consistent with what the program is addressing.	Make sure no other computer device is using the interrupt level specified in your program. If necessary, reset the interrupt level.
	The board configuration is incorrect.	Check the remaining settings in the configuration file.
	The board is incorrectly aligned in the accessory slot.	Check the board for proper seating.
	The board is damaged.	Contact Keithley for technical support. See page 7-6.
Intermittent operation	The I/O bus speed is in excess of 8 MHz.	Reduce I/O bus speed to a maximum of 8 MHz (to change the I/O bus speed, run BIOS setup). See your computer documentation for instructions on running BIOS setup.
	Vibrations or loose connections exist.	Cushion source of vibration and tighten connections to external hardware.
	The board is overheating.	Check environmental and ambient temperature. See the documentation for your computer.
	Electrical noise exists.	Provide better shielding or reroute unshielded wiring.

Table 7-1. Troubleshooting Information (cont.)

Symptom	Possible Cause	Possible Solution
Data appears to be invalid	The I/O bus speed is in excess of 8 MHz.	Reduce I/O bus speed to a maximum of 8 MHz (to change the I/O bus speed, run BIOS setup). See the documentation for your computer for instructions on running BIOS setup.
	An open connection exists.	Check wiring to screw terminal.
	Another system resource is using the specified base address.	Reconfigure the base address of the PIO-SSR Series board. Check the I/O assignments of other system resources and reconfigure, if necessary.
	Transducer is not connected to channel being read.	Check the transducer connections.
	Board is set for single-ended mode while transducer is a differential type, or vice versa.	Check transducer specifications and board configuration.
Computer does not boot.	Board not seated properly.	Check the installation of the board.
	The base address setting of the PIO-SSR Series board conflicts with that of another system resource.	Check the base address settings of your system resources; each address must be unique.
	The power supply of the host computer is too small to handle all the system resources.	Check the needs of all system resources and obtain a larger power supply. Also try removing extra boards from your system.
System lockup	A timing error occurred.	Restart your computer.

If your board is not operating properly after using the information in Table 7-1, continue with the next two sections to further isolate the problem.

Testing the Board and Host Computer

To isolate the problem to the PIO-SSR Series board or to the host computer, use the following steps:

Caution: Removing a board with the power ON can cause damage to your board and/or computer.

1. Turn the power to the host computer OFF, and remove power connections to the computer.
2. While keeping connections to accessories intact, unplug the cable to the main I/O connector of the PIO-SSR Series board.
3. Remove the board from the computer and visually check for damage. If a board is obviously damaged, refer to *Technical Support* on page 7-6 for information on returning the board.
4. With the PIO-SSR Series board out of the computer, check the computer for proper operation. Power up the computer and perform any necessary diagnostics.

At this point, if you have another PIO-SSR Series board that you know is functional, you can test the slot and I/O connections using the instructions in the next section. If you do not have another board, refer to the instructions in *Technical Support* on page 7-6 before calling Keithley for technical support.

Testing the Accessory Slot and I/O Connections

When you are sure that the computer is operating properly, test the computer accessory slot and I/O connections using another PIO-SSR Series board that you know is functional. To test the computer accessory slot and the I/O connections, follow these steps:

1. Remove computer power again, and install a PIO-SSR Series board that you know is functional. Do not make any I/O connections.
2. Turn computer power ON and check operation with the functional board in place. This test checks the computer accessory slot. If you were using more than one board when the problem occurred, use the functional board to test the other slot, as well.
3. If the accessory slots are functional, use the functional board to check the I/O connections. Reconnect and check the operation of the I/O connections, one at a time.
4. If operation fails for an I/O connection, check the individual inputs one at a time for shorts and opens.
5. If operation remains normal to this point, the problem is in the PIO-SSR Series board(s) originally in the computer. If you were using more than one board, try each board one at a time in the computer to determine which is faulty.
6. If you cannot isolate the problem, refer to the next section for instructions on obtaining assistance.

Technical Support

Before returning any equipment for repair, call Keithley for technical support at:

(440) 248-0400

Monday - Friday, 8:00 a.m. - 5:00 p.m., Eastern Time

An applications engineer will help you diagnose and resolve your problem over the telephone. Please make sure that you have the following information available before you call:

PIO-SSR Board Configuration	Model	_____
	Serial Number	_____
	Revision code	_____
	Base address setting	_____
	Interrupt level setting	_____
	Number of channels	_____
	Output signal (V or I)	_____
	Mode (uni. or bip.)	_____
	Output span	_____
	Number SSH-8 boards	_____
	Number EXP boards	_____
Computer	Manufacturer	_____
	CPU type	_____
	Clock speed (MHz)	_____
	KB of RAM	_____
	Video system	_____
	BIOS type	_____
Operating System	Windows version	_____
	Windows mode	_____
Software package	Name	_____
	Serial Number	_____
	Version	_____
	Invoice/Order Number	_____
Compiler (if applicable)	Language	_____
	Manufacturer	_____
	Version	_____
Accessories	Type	_____
	Type	_____
	Type	_____
	Type	_____
	Type	_____
	Type	_____
	Type	_____
	Type	_____

If a telephone resolution is not possible, the applications engineer will issue you a Return Material Authorization (RMA) number and ask you to return the equipment. Include the RMA number with any documentation regarding the equipment.

When returning equipment for repair, include the following information:

- Your name, address, and telephone number.
- The invoice or order number and date of equipment purchase.
- A description of the problem or its symptoms.
- The RMA number on the **outside of the package**.

Repackage the equipment, using the original anti-static wrapping, if possible, and handle it with ground protection. Ship the equipment to:

ATTN: RMA # _____
Repair Department
Keithley Instruments, Inc.
28775 Aurora Road
Cleveland, Ohio 44139

Telephone (440) 248-0400
FAX (440) 248-6168

Note: If you are submitting your equipment for repair under warranty, you must include the invoice number and date of purchase.

To enable Keithley to respond as quickly as possible, you must include the RMA number on the outside of the package.

A

Specifications

Specifications for PIO-SSR Series boards are listed in the following tables.

Table A-1. Digital Input/Output Specifications

Feature	Value
Number of channels	
PIO-SSR-24	24, bidirectional
PIO-SSR-48	48, bidirectional
PIO-SSR-120	120, bidirectional
I/O interface	One 8255A Mode 0 emulation circuit for each group of 24 channels
I/O signal	LS-TTL, non-isolation
Pull-up resistors	10k Ω , one per channel

Table A-2. Interrupt Request Specifications

Feature	Value
Input channels	C0 and C3 of each 24-channel group
Active transition	Rising edge of TTL input signal; minimum pulse duration is 100ns
IRQ levels	3 to 7, 9 to 12, 14, and 15

Table A-3. Input Parameter Specifications

Feature	Value
V_{IH}	2V minimum
V_{IL}	0.8V maximum
I_{IH}	20 μ A maximum at $V_I = 2.7V$
I_{IL}	-0.2mA maximum at $V_I = 0.4V$

Table A-4. Output Parameter Specifications

Feature	Value
V_{OH}	2.4V minimum at $I_{OH} = -3mA$
V_{OL}	0.4V maximum at $I_{OL} = 12mA$
I_{OH}	-15mA maximum
I_{OL}	24mA maximum

Table A-5. General Specifications

Feature	Value
Base I/O address range	Any 32-byte boundary
Base I/O address	DIP switch selectable; default is 300h
External connections	One 50-pin Opto-22 compatible connector for each 24-channel group
Operating temperature	32° to 122°F (0° to 50°C)
Storage temperature	32° to 158°F (0° to 70°C)
Relative humidity	20 to 90%, noncondensing
Power consumption	PIO-SSR-120: +5VDC, 1.6A typical PIO-SSR-48: +5VDC, 800mA typical PIO-SSR-24: +5VDC, 530mA typical
+5V line from all I/O connectors	1A maximum
Physical dimensions	9 x 4.2 x 0.75 inches (229 x 107 x 19 mm)

B

Connector Pin Assignments

Pin assignments for I/O connectors of PIO-SSR Series boards and the edge connector of a CAB-SSR cable are shown in the following diagrams.

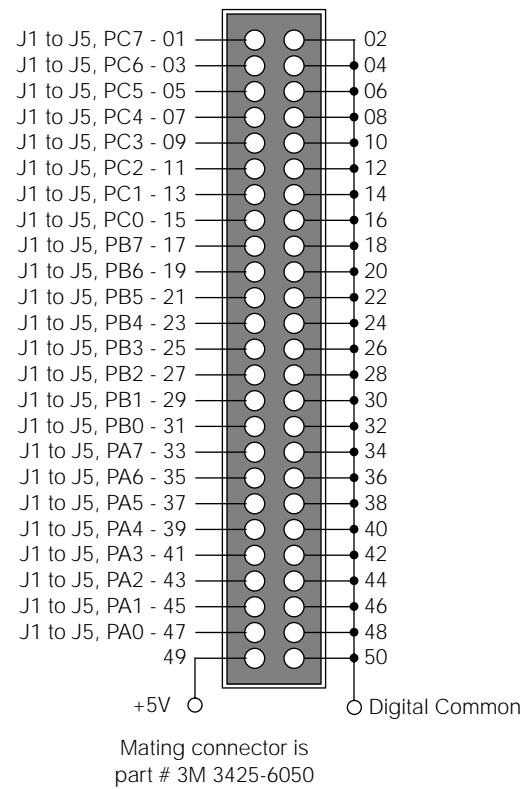

Figure B-1. Pin Assignments for I/O Connectors J1 to J5

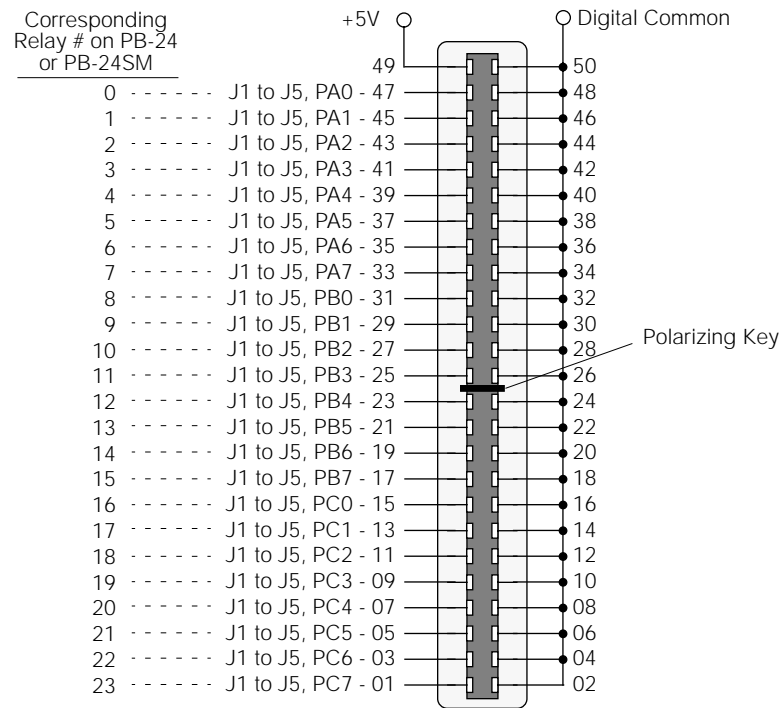

Figure B-2. Pin Assignments for Edge Connector on CAB-SSR Cable

C

CE Mark Information for the PIO-SSR Series

Note: Products that contain the CE Mark are certified to meet European EMC directive 89/336 EEC. If this directive is not of importance to your application, please disregard the information in this appendix.

Keithley certifies that this product has been tested and found to be in compliance with the EMC directive and relevant harmonized standards. This appendix describes the limitation of certification, the declaration of conformity, and the cabling instructions required for the CE Mark configuration.

Limitation of Certification

This certification applies only to the operation of the product (with specified cables and accessories) in the stated configuration and under the stated operational and environmental specifications. Any modification, misuse, or improper or inadequate maintenance of the product by the user voids this certification.

Any deviation from the specific configuration may cause emissions or susceptibility not within the allowed limits required by the stated directive. It is the user's responsibility to demonstrate and maintain compliance with the directive and standards.

Please read the next section, *Declaration of Conformity*, for the specific testing configuration for this product. Consult the Keithley Instruments GMBH office (European importer) or Technical Support in Cleveland, OH, USA, for further information regarding the exact configuration details and testing.

Declaration of Conformity

Application of Council Directive(s)	89/336/EEC
Standard(s) to which Conformity is Declared	EN50081-1, EN50082-1
Manufacturer's Name	Keithley Instruments, Inc.
Importer's Name	Keithley Instruments GMBH
Importer's Address	Landsberger Str.65 D-82110 Germering, Munich
Type of Equipment	Data Acquisition Plug-in Boards
Model Numbers	PIO-SSR Series board with STP-50, CACC-2000, and JACKET shield
Year of Manufacture	1995

I, the undersigned, hereby declare that the equipment specified above conforms to the above Directive(s) and Standard(s).

Place: Taunton, MA USA



(Signature)

Date: 01 January 1996

Mark Urban
(Name)

Quality Assurance Manager
(Position)

Cabling Instructions for the CE Mark Configuration

The PIO-SSR-24 board has one connector, the PIO-SSR-48 board has two connectors, and the PIO-SSR-120 has four connectors, each of which can be connected to an STA-50 through a CACC-2000 cable. For CE Mark compliance, you must shield the CACC-2000 cables. See *Installing Cable Shielding* on page 3-12 for more information.

Index

A

- accessory
 - CAB-SSR cable 1-4, 4-2, 4-3
 - CACC-2000 cable 1-4, 4-1, 4-2
 - jacket, cable 1-4, 3-12
 - PB-24/24SM baseboard 1-4, 4-2, 4-3
 - SSR modules 1-4
 - STP-50 1-4, 4-1, 4-2
- Acrobat
 - for DriverLINX installation 3-2
- address
 - configuration in DriverLINX 3-17
- analog output range
 - configuration in DriverLINX 3-17
- anti-static wrapper 3-1

B

- base I/O address 3-5
 - factory setting 3-7
 - switches 3-7, 3-8
- baseboard, PB-24/24SM 1-4, 4-2, 4-3
- board installation 3-15
- boosting relay drive current 4-5
- browser map
 - DriverLINX installation 3-3

C

- cable
 - CAB-SSR 1-4, 4-2, 4-3
 - CACC-2000 1-4, 4-1, 4-2
 - clamping 3-10
 - installing shield 3-12
 - jacket 1-4, 3-12
- cabling and wiring 4-1

- cache
 - disabling for software installation 3-2
- CD ROM
 - DriverLINX installation 3-3
- CE Mark
 - certification C-1
 - compliance 3-14
- clamping cables 3-10
- computer resources
 - determination for installation 3-2
- configuration
 - using DriverLINX 3-16
- connecting
 - PB-24/24SM baseboard 4-2, 4-3
 - STP-50 4-1, 4-2
- contact bounce, eliminating 4-4
- contact-closure monitor 4-4
- Control Word register 6-10
- counter/timer
 - configuration in DriverLINX 3-17

D

- default
 - setting
 - base I/O address 3-7
 - IRQ level 3-8
- device
 - menu in DriverLINX 3-16
- DriverLINX
 - API DLLs
 - description 1-3
 - configuration with 3-16
 - event viewer 7-1
 - installing and configuring 3-2
 - using to verify board operation 5-1
- drivers
 - installing for applications 3-3

E

- error messages
 - device initialization 7-2
- event log
 - used to detect errors 7-1
- event viewer
 - in DriverLINX 7-1

F

- factory setting
 - base I/O address 3-7
 - IRQ level 3-8
- factory settings 3-5

G

- grounded wrist strap 3-1

I

- I/O
 - address maps 6-8
 - address, setting 3-6
 - circuit, contact-closure monitor 4-4
- I/O bit tests 5-1
 - general information 5-1
 - input read test 5-10
 - output set test 5-6
- inspection 3-1
- installing
 - cable shielding 3-12
 - cables 3-10
 - PIO-SSR Series board 3-15
- interfaces
 - installing for applications 3-3

IRQ level

- Control register 6-11, 6-14
- factory setting 3-8
- priorities 3-9
- setting 3-8
- Status register 6-13

J

- jacket, cable 1-4, 3-12

L

- Learn DriverLINX
 - description 1-3
 - using for configuration 3-16
- logical device
 - configuration in DriverLINX 3-16

M

- manuals
 - DriverLINX 3-4
- Mode 0 emulation 6-7
- modules, SSR 1-4
- monitoring contact closure 4-4

O

- operating modes 6-7

P

- parallel I/O devices 1-1
- PB-24/24SM baseboard 1-4, 4-2, 4-3
- pin assignments
 - CAB-SSR edge connector B-2
 - PIO-SSR I/O connectors B-1

PPI, 8255 6-7
priorities, IRQ level 3-9
problem isolation 7-2
pull-up resistor 1-2, 4-4, A-1

R

register
 Control Word 6-10
 IRQ level Control 6-11, 6-14
 IRQ level Status 6-13
relay drive current, boosting 4-5
RMA
 obtaining for material return 7-8

S

setting
 base I/O address 3-6
 IRQ level 3-8
shipping instructions
 for returning material 7-8
SSR modules 1-4
STP-50 accessory 1-4, 4-1, 4-2
switches
 setting prior to installation 3-2
switches, base I/O address 3-7, 3-8

T

technical support 7-6
 instructions for using 7-6

U

unpacking and inspecting 3-1

V

verify
 board operation
 using DriverLINX 5-1

W

wrapper, anti-static 3-1
wrist strap, grounded 3-1

Specifications are subject to change without notice.

All Keithley trademarks and trade names are the property of Keithley Instruments, Inc. All other trademarks and trade names are the property of their respective companies.

KEITHLEY

Keithley Instruments, Inc.

28775 Aurora Road • Cleveland, Ohio 44139 • 440-248-0400 • Fax: 440-248-6168
1-888-KEITHLEY (534-8453) • www.keithley.com

Sales Offices:

BELGIUM: Bergensesteenweg 709 • B-1600 Sint-Pieters-Leeuw • 02-363 00 40 • Fax: 02/363 00 64
CHINA: Yuan Chen Xin Building, Room 705 • 12 Yumin Road, Dewai, Madian • Beijing 100029 • 8610-6202-2886 • Fax: 8610-6202-2892
FINLAND: Tietäjäsentie 2 • 02130 Espoo • Phone: 09-54 75 08 10 • Fax: 09-25 10 51 00
FRANCE: 3, allée des Garays • 91127 Palaiseau Cédex • 01-64 53 20 20 • Fax: 01-60 11 77 26
GERMANY: Landsberger Strasse 65 • 82110 Germering • 089/84 93 07-40 • Fax: 089/84 93 07-34
GREAT BRITAIN: Unit 2 Commerce Park, Brunel Road • Theale • Berkshire RG7 4AB • 0118 929 7500 • Fax: 0118 929 7519
INDIA: Flat 2B, Willocrissa • 14, Rest House Crescent • Bangalore 560 001 • 91-80-509-1320/21 • Fax: 91-80-509-1322
ITALY: Viale San Gimignano, 38 • 20146 Milano • 02-48 39 16 01 • Fax: 02-48 30 22 74
JAPAN: New Pier Takeshiba North Tower 13F • 11-1, Kaigan 1-chome • Minato-ku, Tokyo 105-0022 • 81-3-5733-7555 • Fax: 81-3-5733-7556
KOREA: 2FL., URI Building • 2-14 Yangjae-Dong • Seocho-Gu, Seoul 137-888 • 82-2-574-7778 • Fax: 82-2-574-7838
NETHERLANDS: Postbus 559 • 4200 AN Gorinchem • 0183-635333 • Fax: 0183-630821
SWEDEN: c/o Regus Business Centre • Frosundaviks Allé 15, 4tr • 169 70 Solna • 08-509 04 679 • Fax: 08-655 26 10
SWITZERLAND: Kriesbachstrasse 4 • 8600 Dübendorf • 01-821 94 44 • Fax: 01-820 30 81
TAIWAN: 1FL., 85 Po Ai Street • Hsinchu, Taiwan, R.O.C. • 886-3-572-9077 • Fax: 886-3-572-9031

© Copyright 2001 Keithley Instruments, Inc.
Printed in the U.S.A.
4/02



Artisan Technology Group is your source for quality new and certified-used/pre-owned equipment

- FAST SHIPPING AND DELIVERY
- TENS OF THOUSANDS OF IN-STOCK ITEMS
- EQUIPMENT DEMOS
- HUNDREDS OF MANUFACTURERS SUPPORTED
- LEASING/MONTHLY RENTALS
- ITAR CERTIFIED SECURE ASSET SOLUTIONS

SERVICE CENTER REPAIRS

Experienced engineers and technicians on staff at our full-service, in-house repair center

*InstraView*SM REMOTE INSPECTION

Remotely inspect equipment before purchasing with our interactive website at www.instraview.com ↗

WE BUY USED EQUIPMENT

Sell your excess, underutilized, and idle used equipment. We also offer credit for buy-backs and trade-ins. www.artisanng.com/WeBuyEquipment ↗

LOOKING FOR MORE INFORMATION?

Visit us on the web at www.artisanng.com ↗ for more information on price quotations, drivers, technical specifications, manuals, and documentation

Contact us: (888) 88-SOURCE | sales@artisanng.com | www.artisanng.com