



Artisan Technology Group is your source for quality new and certified-used/pre-owned equipment

- FAST SHIPPING AND DELIVERY
- TENS OF THOUSANDS OF IN-STOCK ITEMS
- EQUIPMENT DEMOS
- HUNDREDS OF MANUFACTURERS SUPPORTED
- LEASING/MONTHLY RENTALS
- ITAR CERTIFIED SECURE ASSET SOLUTIONS

SERVICE CENTER REPAIRS

Experienced engineers and technicians on staff at our full-service, in-house repair center

*InstraView*SM REMOTE INSPECTION

Remotely inspect equipment before purchasing with our interactive website at www.instraview.com ↗

WE BUY USED EQUIPMENT

Sell your excess, underutilized, and idle used equipment. We also offer credit for buy-backs and trade-ins. www.artisanng.com/WeBuyEquipment ↗

LOOKING FOR MORE INFORMATION?

Visit us on the web at www.artisanng.com ↗ for more information on price quotations, drivers, technical specifications, manuals, and documentation

Contact us: (888) 88-SOURCE | sales@artisanng.com | www.artisanng.com

DS1104 R&D Controller Board

Cost-effective system for controller development

Highlights

- Single-board system with real-time hardware and comprehensive I/O
- Cost-effective
- PCI hardware for use in PCs



Application Areas

The real-time hardware based on PowerPC technology and its set of I/O interfaces make the controller board an ideal solution for developing controllers in various fields, such as drives, robotics, and aerospace. The board is used in many university laboratories.

Key Benefits

The DS1104 R&D Controller Board upgrades your PC to a powerful development system for rapid control prototyping („R&D“ stands for research & development). Real-Time Interface (RTI) provides Simulink® blocks for graphical I/O configuration. The board can be installed in virtually any PC with a free 5-V PCI slot.

Using Real-Time Interface

With Real-Time Interface (RTI), you can easily run your function models on the DS1104 R&D Controller Board. You can configure all I/O graphically, insert the blocks into a Simulink block diagram, and generate the model code via Real-Time Workshop®. The real-time model is compiled, downloaded, and started automatically. This reduces the implementation time to a minimum.

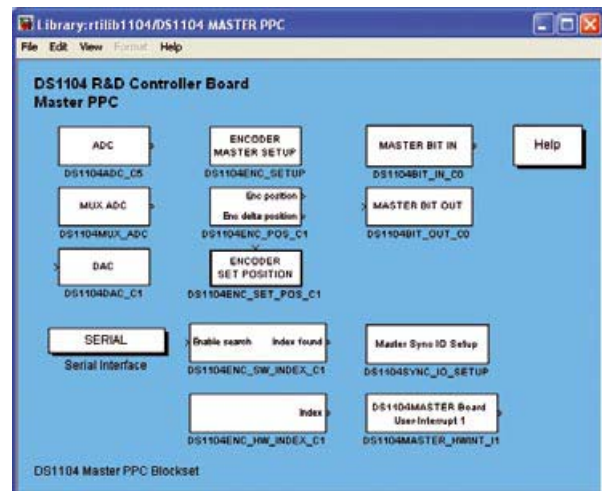

Technical Details

Parameter		Specification
Processor		<ul style="list-style-type: none"> ■ MPC8240 processor with PPC 603e core and on-chip peripherals ■ 64-bit floating-point processor ■ CPU clock: 250 MHz ■ 2 x 16 KB cache, on-chip ■ On-chip PCI bridge (33 MHz)
Memory	Global memory	■ 32 MB SDRAM
	Flash memory	■ 8 MB
Timer	4 general-purpose timers	<ul style="list-style-type: none"> ■ 32-bit down counter ■ Reload by hardware ■ 80-ns resolution
	1 sampling rate timer (decrementer)	<ul style="list-style-type: none"> ■ 32-bit down counter ■ Reload by software ■ 40-ns resolution
	1 time base counter	<ul style="list-style-type: none"> ■ 64-bit up counter ■ 40-ns resolution
Interrupt controller		<ul style="list-style-type: none"> ■ 5 timer interrupts ■ 2 incremental encoder index line interrupts ■ 1 UART interrupt ■ 1 slave DSP interrupt ■ 1 slave DSP PWM interrupt ■ 5 A/D converter (end of conversion) interrupts ■ 1 host interrupt ■ 4 external interrupts (user interrupts)
A/D converter	Channels	<ul style="list-style-type: none"> ■ 4 multiplexed channels equipped with one sample & hold A/D converter (1x16-bit) ■ 4 parallel channels each equipped with one sample & hold A/D converter (4x12-bit) ■ Note: 5 A/D converter channels (1x16-bit and 4x12-bit) can be sampled simultaneously
	Resolution	<ul style="list-style-type: none"> ■ Multiplexed channels: 16 bit ■ Parallel channels: 12 bit
	Input voltage range	■ ±10 V
	Conversion time	<ul style="list-style-type: none"> ■ Multiplexed channels: 2 μs¹⁾ ■ Parallel channels: 800 ns¹⁾
	Offset error	■ ±5 mV
	Gain error	<ul style="list-style-type: none"> ■ Multiplexed channels: ±0.25% ■ Parallel channels: ±0.5%
	Offset drift	■ 40 μV/K
	Gain drift	■ 25 ppm/K
	Signal-to-noise ratio	<ul style="list-style-type: none"> ■ Multiplexed channels: >80 dB ■ Parallel channels: >65 dB
D/A converter	Channels	■ 8 channels
	Resolution	■ 16-bit
	Output range	■ ±10 V
	Settling time	■ Max. 10 μs (full-scale, accuracy ½ LSB)
	Offset error	■ ±1 mV
	Gain error	■ ±0.1%
	Offset drift	■ 130 μV/K
	Gain drift	■ 25 ppm/K
	Signal-to-noise ratio	■ >80 dB
Digital I/O	I _{max}	■ ±5 mA
	Channels	<ul style="list-style-type: none"> ■ 20-bit parallel I/O ■ Single bit selectable for input or output
	Voltage range	■ TTL input/output levels
	I _{out, max}	■ ±5 mA

¹⁾ Speed and timing specifications describe the capabilities of the hardware components and circuits of our products. Depending on the software complexity, the attainable overall performance figures can deviate significantly from the hardware specifications.

Parameter		Specification
Digital incremental encoder interface	Channels	<ul style="list-style-type: none"> ■ 2 independent channels ■ Selectable single-ended (TTL) or differential (RS422) input (software programmable for each channel)
	Position counters	<ul style="list-style-type: none"> ■ 24-bit resolution ■ Max. 1.65 MHz input frequency, i.e., fourfold pulse count up to 6.6 MHz ■ Counter reset or reload via software
	Sensor supply voltage	<ul style="list-style-type: none"> ■ 5 V/0.5 A
Serial interface	Configuration	<ul style="list-style-type: none"> ■ Single UART (universal asynchronous receiver and transmitter) with FIFO ■ PLL-driven UART for accurate baud rate selection ■ RS232/RS422/RS485 compatibility
	Baud rate	<ul style="list-style-type: none"> ■ Up to 115.2 kBd (RS232) ■ Up to 1 MBd (RS422/RS485)
Slave DSP	Type	<ul style="list-style-type: none"> ■ Texas Instruments TMS320F240 DSP ■ 16-bit fixed-point processor
	Clock rate	<ul style="list-style-type: none"> ■ 20 MHz
	Memory	<ul style="list-style-type: none"> ■ 64Kx16 external code memory ■ 28Kx16 external data memory ■ 4Kx16 dual-port memory for communication ■ 32 KB flash memory
	I/O channels	<ul style="list-style-type: none"> ■ 10 PWM outputs ■ 4 capture inputs ■ 1 serial peripheral interface
	Input voltage range	<ul style="list-style-type: none"> ■ TTL input/output level ■ A/D converter inputs: 0 ... 5 V
	Output current	<ul style="list-style-type: none"> ■ Max. ± 13 mA
Host interface		<ul style="list-style-type: none"> ■ Requires one 33 MHz / 32-bit 5-V PCI slot
Physical characteristics	Physical size	<ul style="list-style-type: none"> ■ 185 x 107 mm (7.28 x 4.2 in)
	Ambient temperature	<ul style="list-style-type: none"> ■ 0 ... 55 °C (32 ... 131 °F)
	Cooling	<ul style="list-style-type: none"> ■ Active cooling by fan
	Power consumption	<ul style="list-style-type: none"> ■ 18.5 W
	Power supply	<ul style="list-style-type: none"> ■ +5 V $\pm 5\%$, 2.5 A ■ +12 V $\pm 5\%$, 0.3 A ■ -12 V $\pm 5\%$, 0.2 A

Order Information

Product	Order Number
DS1104 R&D Controller Board	■ DS1104

Relevant Software and Hardware

Software	Order Number
Included	
■ DS1104 Real-Time Library	–
■ Experiment and Platform Manager for hardware management	–
Required	
■ Real-Time Interface (RTI) (p. 166)	■ RTI
■ Microtec C Compiler (p. 189)	■ CCPPPC
Optional	
■ ControlDesk Standard – Operator Version (p. 190)	■ CS_O
■ ControlDesk Standard – Developer Version (p. 190)	■ CS_D
■ MLIB/MTRACE (p. 232)	■ MLIB/MTRACE
■ CLIB (p. 231)	■ CLIB

Hardware	Order Number
Optional	
■ Connector Panel (p. 338)	■ CP1104
■ Combined Connector/LED Panel (p. 338)	■ CLP1104
■ Adapter cable for DS1104	■ ADP_CAB1104

Block Diagram

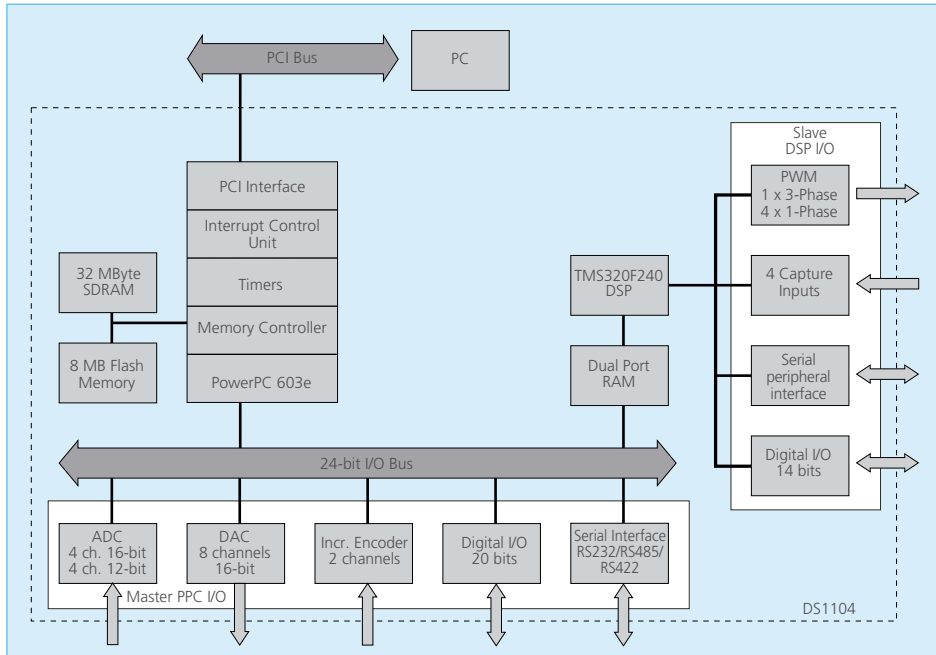

Induction Motor Control

Use Case

Drive Control

In this use case, an induction motor controller is developed with the DS1104. The DS1104 is well suited for drive control: while in this use case the slave DSP system calculates the PWM signals, the PowerPC's calculation power supports convenient simulation. With an experiment software such as ControlDesk (p. 190), measuring and parameterization can be performed during run-time.

Determining Values

One of the board's incremental encoder interfaces picks up the encoder signal of the motor, while two A/D converters are required to analyze the motor currents. The controller board calculates the control algorithm on the basis of the measured values and determines the corresponding pulse width modulation (PWM). The three-phase PWM signals are generated on the board's DSP subsystem and determine the converter's output voltage and frequency.

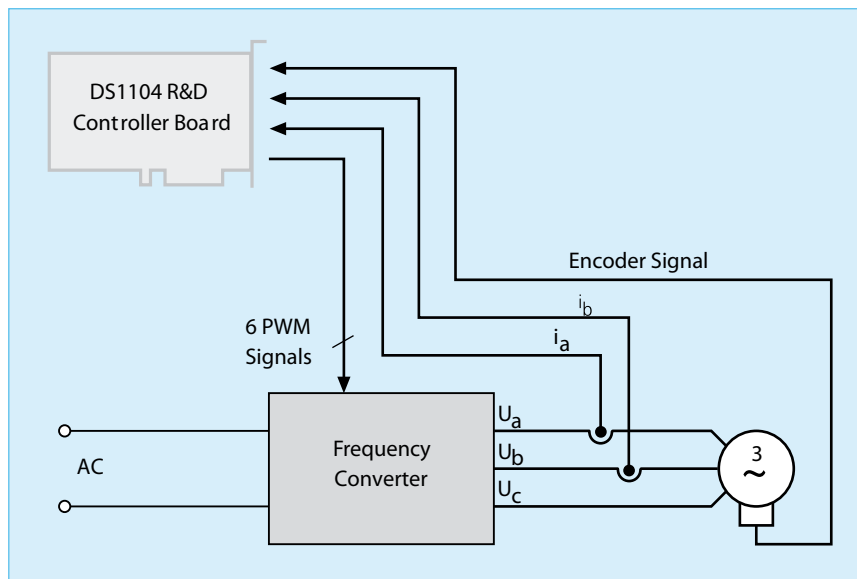



Artisan Technology Group is your source for quality new and certified-used/pre-owned equipment

- FAST SHIPPING AND DELIVERY
- TENS OF THOUSANDS OF IN-STOCK ITEMS
- EQUIPMENT DEMOS
- HUNDREDS OF MANUFACTURERS SUPPORTED
- LEASING/MONTHLY RENTALS
- ITAR CERTIFIED SECURE ASSET SOLUTIONS

SERVICE CENTER REPAIRS

Experienced engineers and technicians on staff at our full-service, in-house repair center

*InstraView*SM REMOTE INSPECTION

Remotely inspect equipment before purchasing with our interactive website at www.instraview.com ↗

WE BUY USED EQUIPMENT

Sell your excess, underutilized, and idle used equipment. We also offer credit for buy-backs and trade-ins. www.artisanng.com/WeBuyEquipment ↗

LOOKING FOR MORE INFORMATION?

Visit us on the web at www.artisanng.com ↗ for more information on price quotations, drivers, technical specifications, manuals, and documentation

Contact us: (888) 88-SOURCE | sales@artisanng.com | www.artisanng.com