



Artisan Technology Group is your source for quality new and certified-used/pre-owned equipment

- FAST SHIPPING AND DELIVERY
- TENS OF THOUSANDS OF IN-STOCK ITEMS
- EQUIPMENT DEMOS
- HUNDREDS OF MANUFACTURERS SUPPORTED
- LEASING/MONTHLY RENTALS
- ITAR CERTIFIED SECURE ASSET SOLUTIONS

SERVICE CENTER REPAIRS

Experienced engineers and technicians on staff at our full-service, in-house repair center

*InstraView*SM REMOTE INSPECTION

Remotely inspect equipment before purchasing with our interactive website at www.instraview.com ↗

WE BUY USED EQUIPMENT

Sell your excess, underutilized, and idle used equipment. We also offer credit for buy-backs and trade-ins. www.artisanng.com/WeBuyEquipment ↗

LOOKING FOR MORE INFORMATION?

Visit us on the web at www.artisanng.com ↗ for more information on price quotations, drivers, technical specifications, manuals, and documentation

Contact us: (888) 88-SOURCE | sales@artisanng.com | www.artisanng.com

3

System Design Considerations

Introduction

Although there are many possible configurations of the laser and optics, all Agilent laser measurement systems have these basic parts in common:

- A laser source, to produce the two optical frequencies f_1 and f_2 and generate the reference signal. In discussions in this manual, f_1 is the lower frequency and f_2 is the higher.
- Beam-directing optics, to direct all or part of the laser beam to each measurement axis of the system, using right-angle bends.
- Measurement optics, to separate the two optical frequencies, direct them over the reference and measurement paths, and recombine them.
- One receiver per measurement axis, to detect the difference in optical frequencies and produce the measurement signal for that axis.
- Electronics to convert the measurement and reference signals into displacement data.

Two important characteristics of Agilent interferometers must be emphasized:

- Only the change in relative position of the optics is detected.
- Either optical component may move, as long as optical alignment is maintained. If the interferometer is fixed and the retroreflector is the moving component (toward or away from the interferometer), motion with respect to its original position is detected. Conversely, if the retroreflector is fixed, the interferometer can be the moving component.

Agilent laser position transducers can detect and measure all linear motions; that is, 3 degrees of the 18 degrees of freedom defined in the Glossary. Small angle measurements may be made by multiple measurements on the same axis.

The measurement system is relatively insensitive to all other motions, as briefly described below. See Figure 3-1.

POSSIBLE COMPONENT MOTIONS

Figure 3-1. Possible component motions

1. Motion of the receiver or laser head along the beam path (X) has no effect on the measurement since both f_1 and f_2 would exhibit Doppler shift.
2. Small motions of the laser head, receiver, interferometer, or retroreflector in a direction perpendicular to the beam path (Y or Z) have no effect on the measurement. The only restriction is that sufficient light returns to the receiver.
3. Angular motion (pitch or yaw) of the laser head about the Z or Y axis has the effects described below:
 - a. It introduces a measurement error (cosine error).
 - b. It may displace the laser beam so that insufficient light returns to operate the receiver.
4. Although the laser head or the receiver may be rotated in 90° increments about the beam axis (roll), other roll deviations from the four optimum positions degrade the measurement signal. If either the laser head or receiver is rotated 45° about the beam axis, all position information will be lost because the receiver will not be able to distinguish between the two frequencies.
5. Angular motion of the receiver about the Y or Z axis has no effect on the measurement, within alignment limits specified for the receiver. (Receiver specifications are given in Chapter 8, "Receivers," of this manual.)
6. Angular motions of the interferometer and retroreflector depend on the particular components for limitations.

Accuracy Considerations

Several factors outside the laser measurement system can affect system accuracy. These factors (the measurement environment, machine and material temperature, and the optics installation) and their interrelationships must be understood in order to predict the performance of the system. Detailed descriptions and methods of compensation are given in Chapter 15, “Accuracy and Repeatability,” of this manual.

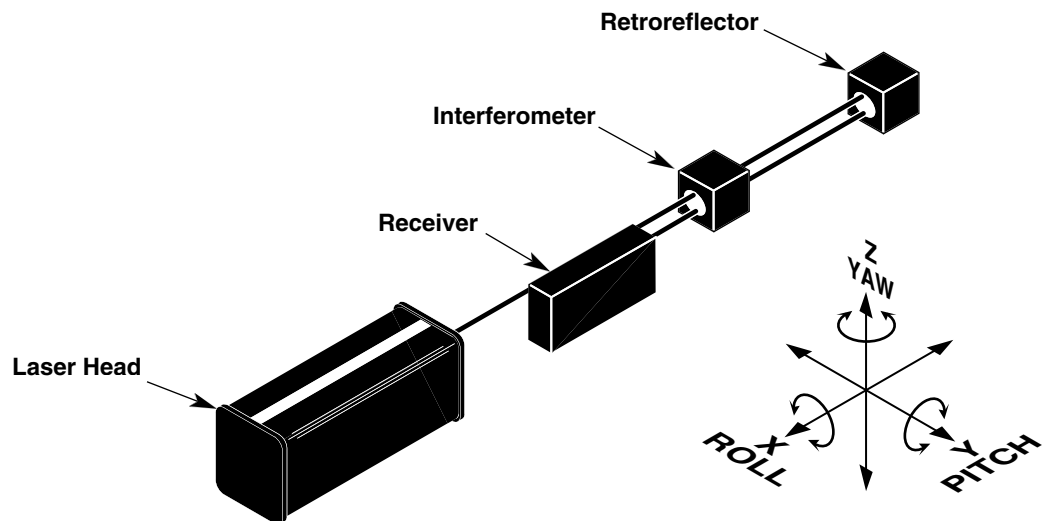
Generally, Agilent laser measurement systems offer automatic compensation for air environments and also for temperature changes of the work material. For a temperature-controlled environment ($20 \pm 0.5^\circ \text{C}$), typical system accuracy using air sensor automatic compensation is 1.5 ppm. Using the Agilent 10717A Wavelength Tracker for compensation, the measurement repeatability is on the order of ± 0.2 ppm, depending on the environment.

Determining What Equipment is Needed

First, sketch out your optical configuration. Remember:

- Each measurement axis (except for the Agilent 10717A Wavelength Tracker) requires an interferometer and associated retroreflector.
- Each measurement axis after the first one requires a beam splitter. The number of beam splitters required is $n-1$, where n is the number of measurement axes.
- If an Agilent 10717A Wavelength Tracker is used, it counts as a measurement axis.
- If a multiaxis interferometer, such as the Agilent 10721A, Agilent 10735A, Agilent 10736A, or Agilent 10737L,R is used, be sure the beam-directing optics you select will provide enough laser beam power to drive the receivers through the multiple measurement paths of the interferometer.
- Beam benders should be arranged so their exiting beams are perpendicular to one polarization plane of the incoming laser beam.
- Rotation of the beam during bending can result in problems due to the effects of polarization.
- Beam splitters should be arranged so:

Chapter 3 System Design Considerations
Determining What Equipment is Needed

- one exiting beam is along the axis of the incoming beam, and the second beam is perpendicular to one polarization of the incoming beam, as described above for beam benders.
- Each measurement axis requires an interferometer. The nature of the measurement(s) to be made influences the interferometer choice.
- Each measurement axis (including the Agilent 10717A Wavelength Tracker) requires a receiver. The interferometer used can influence the receiver choice. *Note that the Agilent 5519A and Agilent 5519B laser heads include a built-in receiver.*

Then, from your layout, determine your optics needs. Choose the Agilent laser head, optical and electronic components accordingly. Decide on a compensation scheme and, finally, select cables. Table 3-1 summarizes the equipment choices. For advice and help, contact Agilent Technologies.

Table 3-1. Equipment choices

Component	Comment(s)
Laser	One required per system
Agilent 5517A	Lowest velocity, largest size, 6 mm beam
Agilent 5517B	25% higher velocity than Agilent 5517A, small size, 6 mm beam
Agilent 5517C Std	Higher velocity than Agilent 5517A and 5517B, small size 6 mm beam diameter
5517C-003	3 mm beam diameter
5517C-009	9 mm beam diameter
Agilent 5517D	Highest velocity, small size, 6 mm beam
Agilent 5519A	Largest size, built-in receiver and power supply used in the Agilent 5529A Dynamic Calibrator System and Metrology applications.
Agilent 5519B	Largest size, built-in receiver and power supply, higher velocity than Agilent 5519A; used in the Agilent 5529A Dynamic Calibrator System and Metrology applications.
Beam-Directing Optics	Order as required to manipulate beam path to your configuration
Agilent 10567A	Dual-Beam Beam Splitter, useful in vacuum applications
Agilent 10700A	33% Beam Splitter
Agilent 10701A	50% Beam Splitter
Agilent 10707A	Beam Bender
Agilent 10725A	50% Beam Splitter, no housing
Agilent 10726A	Beam Bender, no housing
Agilent N1203C	Precision Beam Translator
Agilent N1204C	Precision Horizontal Beam Bender

Chapter 3 System Design Considerations
Determining What Equipment is Needed

Table 3-1. Equipment choices (Continued)

Component	Comment(s)
Beam-Directing Optics (Continued)	
Agilent N1207C	Precision Vertical Beam Bender
Measurement Optics	One Interferometer-plus-Reflector pair required per axis
Agilent 10702A	Linear Interferometer
Agilent 10702A-001	Same as above, but with wedge windows — required if interferometer is the moving component.
Agilent 10703A	Reflector — paired with Agilent 10702A
Agilent 10704A	Reflector — paired with Agilent 10705A
Agilent 10705A	Single Beam Interferometer
Agilent 10706A	Plane Mirror Interferometer
Agilent 10706B	High Stability Plane Mirror Interferometer
Agilent 10715A	Differential Interferometer
Agilent 10715A-001	Differential Interferometer, turned configuration
Agilent 10716A	High Resolution Interferometer
Agilent 10716A-001	High Resolution Interferometer, turned configuration
Agilent 10717A	Wavelength Tracker (requires measurement receiver and cable)
Agilent 10719A	One-axis Differential Interferometer, requires 3 mm beam from Agilent 5517C-003
Agilent 10721A	Two-axis Differential Interferometer, requires 3 mm beam from Agilent 5517C-003
Agilent 10724A	Plane Mirror Reflector
Agilent 10735A	Three-axis Interferometer
Agilent 10736A	Three-axis Interferometer
Agilent 10736A-001	Three-axis Interferometer with Beam Bender
Agilent 10737L	Compact three-axis Interferometer, left
Agilent 10737R	Compact three-axis Interferometer, right
Agilent 10766A	Linear Interferometer
Agilent 10767A	Linear Retroreflector — paired with Agilent 10766A
Agilent 10767B	Lightweight Retroreflector
Agilent 10770A	Angular Interferometer
Agilent 10771A	Angular Retroreflector — paired with Agilent 10770A
Agilent 10774A	Short Range Straightness Optics (matched set)
Agilent 10775A	Long Range Straightness Optics (matched set)

Chapter 3 System Design Considerations
Determining What Equipment is Needed

Table 3-1. Equipment choices (Continued)

Component	Comment(s)
Optic Mounts	Adjustable mounts simplify installation and alignment
Agilent 10710B	Use with Agilent 10700A, 10701A, 10705A, 10707A
Agilent 10711A	Use with Agilent 10702A, 10706A, 10706B, 10715A, 10716A
Measurement Receivers	One required per axis; one required with Agilent 10717A Wavelength Tracker (if used)
Agilent 10780C	Receiver
Agilent 10780F	Remote Receiver
Agilent E1708A	Remote Dynamic Receiver
Agilent E1709A	Remote High-Performance Receiver
Receiver Cables for use with Agilent 10895A VME Axis board — one cable per system	
Agilent 10790A	5 meters long
Agilent 10790B	10 meters long
Agilent 10790C	20 meters long
Receiver Cables for use with Agilent 10885A PC Axis Board or Agilent N1231A PCI Three-Axis Board — one cable per receiver	
Agilent 10880A	5 meters long
Agilent 10880B	10 meters long
Agilent 10880C	20 meters long
Laser Head Cables for Agilent 5517A/B/C/D Laser Head used with Agilent 10885A, 10889B, or N1231A axis boards (cable has a DIN connector for connecting to the Agilent 10884A Power Supply to provide power to the laser head) — one cable per system	
Agilent 10881A	3 meters long
Agilent 10881B	7 meters long
Agilent 10881C	20 meters long
Laser Head Cables for Agilent 5517A/B/C/D Laser Head used with Agilent 10885A, 10889B, or N1231A axis boards (cable has spade lugs for connection to a power supply to provide power to the laser head)— one cable per system	
Agilent 10881D	3 meters long
Agilent 10881E	7 meters long
Agilent 10881F	20 meters long
Laser Head Cables for Agilent 5519A/B Laser Head used with Agilent 10887P Programmable PC Calibrator Board in the Agilent 5529A system— one cable per system	
Agilent 10882A	3 meters long
Agilent 10882B	7 meters long
Agilent 10882C	20 meters long

Chapter 3 System Design Considerations
Determining What Equipment is Needed

Table 3-1. Equipment choices (Continued)

Component	Comment(s)
Accessory Reflectors	Order as required for your application
Agilent 10728A	Plane Mirror
Agilent 10769A	Beam Steering Mirror
Agilent 10772A	Turning Mirror
Agilent 10773A	Flatness Mirror
High Performance Laser Head Cable for Agilent 5517B/C/D Laser Head used with the Agilent 10897B and 10898A VME Axis boards, and N1231A PCI Axis board <i>(cable has a DIN connector for connecting to the Agilent 10884A Power Supply to provide power to the laser head)</i> — one cable per system	
Agilent N1251A	3 meters (9.8 feet)
Agilent N1251B	7 meters (23.0 feet)
High Performance Receiver Cables for use with Agilent 10897B and 10898A VME Axis boards, and N1231A PCI Axis board — one cable per receiver	
Agilent N1250A	5 meters (16.4 feet)
Agilent N1250B	10 meters (32.8 feet)

Electronic Components

Transducer Systems

There are three different types of electronics for Agilent laser transducer systems. These electronics use different backplanes and have different performance and outputs. Full details are given in the appropriate electronics system manuals.

PC-Based Electronics

The Agilent 10885A PC Axis Board is compatible with PC (ISA) backplanes.

Up to six Agilent 10885As may be used in a single system.

VME Compatible Electronics

The Agilent 10898A High Resolution VMEbus Dual Laser Axis Board, Agilent 10897B High Resolution VMEbus Laser Axis Board, and Agilent 10895A VMEbus Laser Axis Board are compatible with VME backplanes.

The Agilent 10896B VME Laser Compensation Board is also compatible with VME backplanes and works with the Agilent 10895A. Up to six Agilent 10895As and several Agilent 10896As (up to one for each Agilent 10895A) may be used in a single system.

PC-Based PCI Electronics

The Agilent N1231A PCI Three-Axis Board is optimized for connection to a PMAC motion control system from Delta Tau[®]. It is a full size, Universal (3.3V and 5.0V signaling compatibility), 32-bit, 33 MHz, PCI Rev. 2.2 compliant card for use in PC-compatible controllers as part of an Agilent laser interferometry position measurement system.

Electronic Components

Calibrator System Electronics

Agilent 5529A Dynamic Calibrator

The Agilent 5529A Dynamic Calibrator is a laser system used to ensure the accuracy of a machine's motion and positioning. Controlled through your PC (with Microsoft® Windows installed), the system is able to collect and analyze measurement data for a number of measurements. The Agilent 5529A Dynamic Calibrator typically includes the following electronic components:

- Agilent 5519A/B Laser Head
- Agilent 10886A PC Compensation board (optional, for automatic compensation)
- Agilent 10887B PC Calibrator Board
- Agilent 10751C,D Air sensor and Agilent 10757D,E,F Material Temperature sensor(s) (optional, as required)
- Agilent 10888A Remote Control units (optional)

The PC compensation boards provide the interfaces between the air and material temperature sensors and your PC. The boards convert the analog electrical voltages from the sensors to digital forms that the PC uses to calculate the compensation factors. These factors adjust for changes in the systems' operating environments. Typical sensors used with each Agilent 10886A PC Compensation board are the Agilent 10751C,D Air Sensor and one to three Agilent 10757D,E,F Material Temperature sensors.

The Agilent 10887B PC Calibrator Board enable the PC to perform laser calibrator-related functions with the Agilent 5529A calibrator software.

An Agilent Two-Axis 5529A/5529A Dynamic Calibrator and an Agilent 55292A USB Expansion Module are also available. The USB software hosts up to five axes on one computer.

Adjustment Considerations

In general, when aligning the Agilent optics, it will be necessary to adjust most or all of the optical components. Most optics are not referenced to their housings since simple adjustments by the user can usually provide optimum alignment. The Agilent 10710B and Agilent 10711A Adjustable Mounts should be used to provide the adjustment capability for most optical components.

There are a few exceptions, however. Certain optics designed for multi-axis systems provide referenced housings. Installation and alignment of these optics depends on the optic; refer to specific instructions for these optics (Agilent 10719A, Agilent 10721A, Agilent 10735A, Agilent 10736A) elsewhere in this manual.

Other optics require you to fabricate your own mounts.

In general, the alignment procedures are performed with all optical components in place. Your measurement system design should allow for adjustment of the laser, optics, and receivers during alignment.

Laser beam and optics protection

The laser measurement system requires protection against unintentional laser beam blockage and air turbulence problems. In some applications, such as machine tools, protection should be provided to prevent metal chips or cutting fluid from interfering with the measurements. Also, the optical components usually require protection to prevent contamination of the optical surfaces by oil or cutting fluid. In applications which are considered “clean”, protection may not be needed.

If protection of the laser beam and optical components is required, there are two general types: moving-component protection and stationary component protection.

In many applications, the only moving component is the interferometer or the reflector. Many of the beam benders are stationary and only direct the laser beam to the measurement axis. In these cases, it is only necessary to provide fixed tubing for the laser beam and some type of sealed enclosure for the optics. Since only one laser beam of approximately 6 mm (0.24 inch) in diameter is involved, relatively small diameter tubing can be used. Since either the interferometer or the reflector is moving during the measurement, protecting the laser beam and the moving components requires a telescoping cover or a cover that is self-sealing. A wide variety of commercially available protective covers are suitable for this purpose.

Adjustment Considerations

Figure 3-2 illustrates techniques for protecting the laser beam and optical components with different types of protective covering. Note that the cover for the retroreflector allows the retroreflector to be moved very close to the interferometer. This helps minimize the deadpath errors. Chapter 15, "Accuracy and Repeatability," in this manual has more details on minimizing deadpath.

PROTECTIVE COVERS

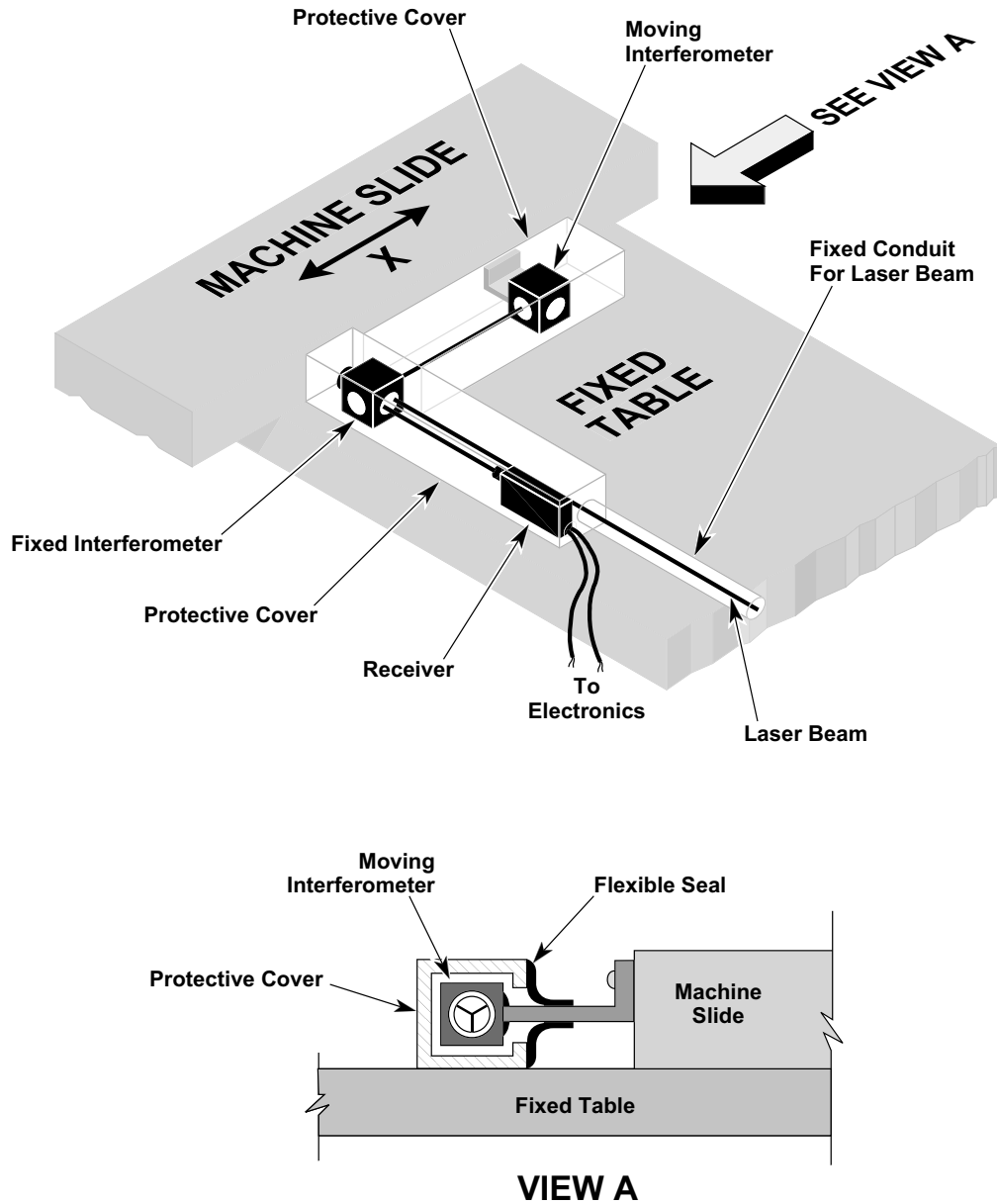

Figure 3-2. Protective covers for optics and laser beam

Adjustment Considerations

Figure 3-3 shows a different type of protective cover. Again, the mechanical arrangement allows the retroreflector to be close to the interferometer at the closest point of travel, even though the telescoping cover is not entirely collapsible. Another type of protective cover is the flexible bellows. This is generally used for short travel distances.

COLLAPSIBLE SPIRAL COVER

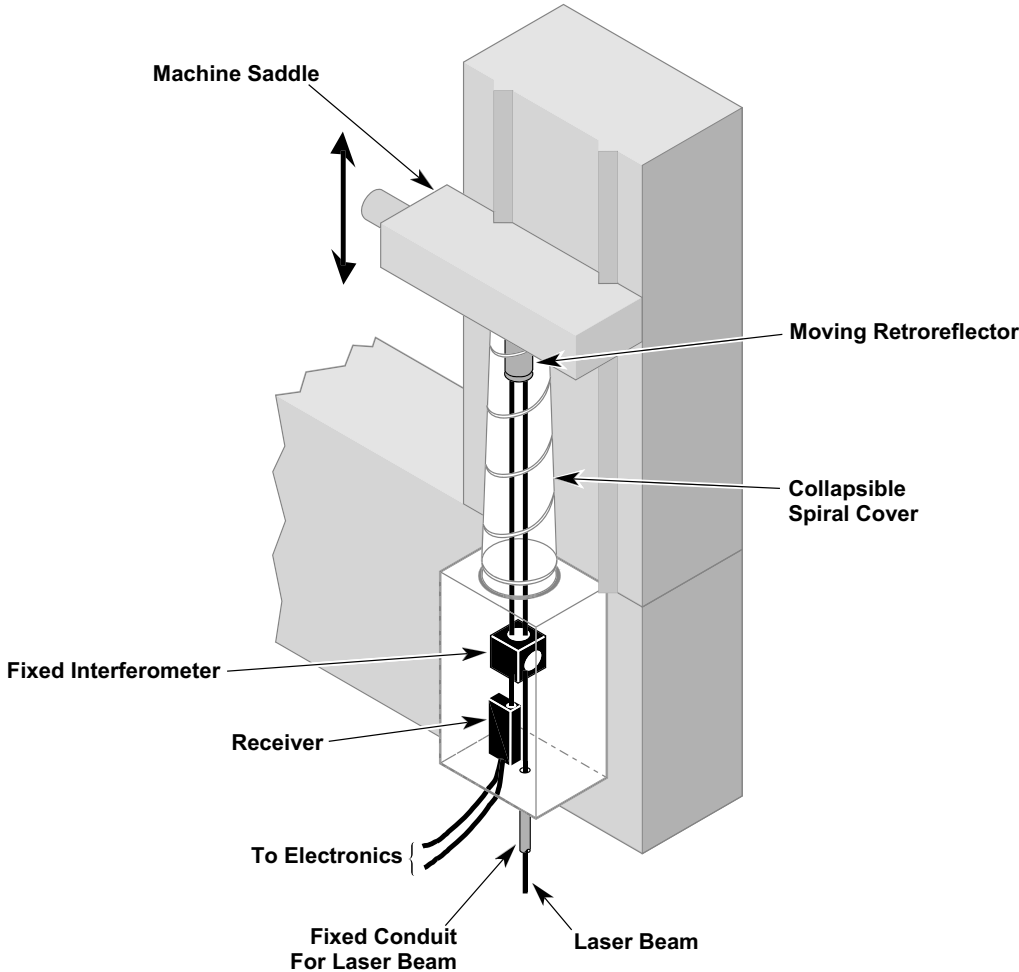

Figure 3-3. Collapsible spiral cover for movable retroreflector

System Grounding

Be sure to consider electrical grounding requirements as you plan and install your Agilent laser measurement. Grounding is important for safety reasons, but your grounding arrangement can also affect your laser system's performance.

Best practice requires that all system components that are connected to electrical ground should be connected to ground at a common point, not at separate points. Your electrical ground connections should radiate from a single point. Using more than one grounding point could create a ground loop, which could introduce an unacceptable level of electrical noise into the electronics.

Signal grounds on each Agilent laser head, each Agilent receiver and the Agilent laser measurement system electronics are all connected to their respective chassis. To prevent ground loops they all should be grounded through one common point.

The Agilent 10780C or Agilent 10780F receiver mounting is isolated from ground by using the nylon screws supplied.

A system using VME electronics (Agilent 10898A, Agilent 10897B, and Agilent 10895A axis boards), PC electronics (Agilent 10885A axis board) or PCI electronics (N1231A axis board) should be grounded through the electronics power line.

Laser Head

Orientation

An Agilent laser head may be mounted in any orientation as long as it is positioned to direct the beam into the optical system parallel to or orthogonal with the machine axes being measured. See Chapter 5, “Laser Heads,” in of this manual for more information about laser head orientation.

Mounting plane tolerance

The plane defined by the three mounting feet on the laser head must be parallel to either the bottom or sides of the beam-splitters and of the beam-bender housings to within $\pm 3^\circ$, and to the bottom or sides interferometers to within $\pm 11^\circ$. This ensures that the polarization axes of the interferometers are oriented properly relative to the polarization vectors of the laser beam (Figure 3-4). The laser head can be rotated in 90° increments about the beam axis (roll) without affecting the system performance, but the measurement direction sense will change with each 90° rotation.

Allow 50 mm (2 inches) clearance around the laser head for easy servicing.

Allow at least 100 mm (4 inches) clearance at the back of the laser head for cable connections.

LASER POSITION TRANSDUCER MOUNTING

Figure 3-4. Laser position transducer mounting

Pointing stability

To maintain good pointing stability, it is good practice to use kinematic mounting principles. Refer to Chapter 5, “Laser Heads,” in this manual for more information about laser head pointing stability.

Thermal isolation

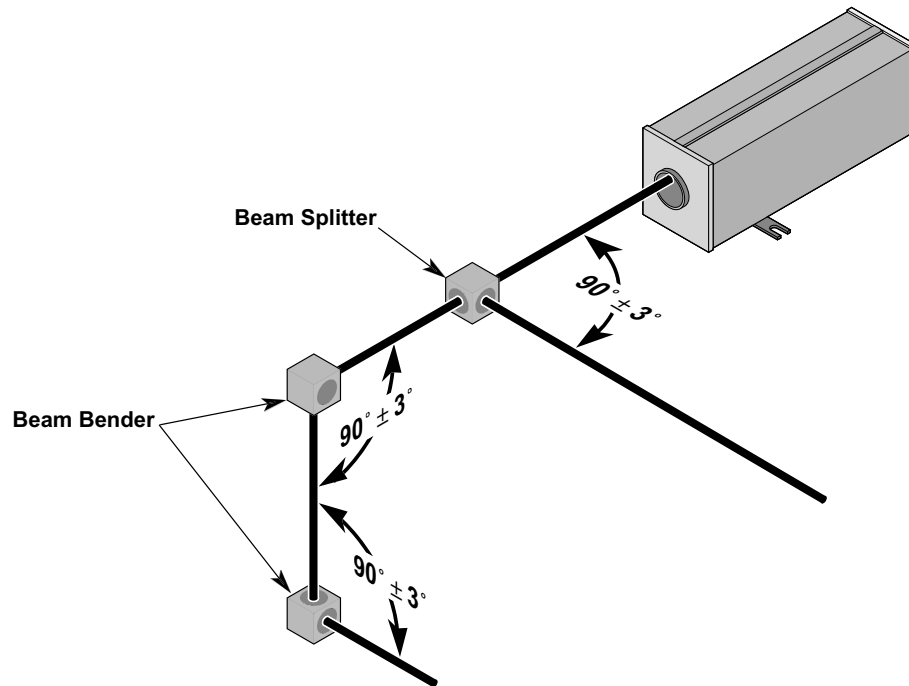
Because there is some heat dissipation from the laser heads, you should choose the mounting method and location with care. Where possible, mount the laser head away from the measuring area, to avoid any thermal effects.

Vibration isolation

Since the system measures only the relative motion between the interferometer and reflector, measurements are not affected by vibration along the beam axis of the laser source or the receiver.

Optics

When vibration of the laser head causes displacement of the beam (perpendicular to beam axis) at an interferometer or receiver, the beam signal power can fluctuate. If this fluctuation is too great, insufficient beam signal will arrive at the receiver, causing a “measurement signal error.”

Magnetic shielding

Agilent laser heads contain a permanent magnet. When installing an Agilent laser measurement system in an application sensitive to magnetic fields, shielding around the laser head may be required.

Mounting

See Chapter 5, “Laser Heads,” in this manual for laser head installation and mounting instructions.

The laser source in Agilent 5517C-009 9-mm Laser Head is referenced to locations on the outside of the laser head, allowing the laser head to be installed in a predefined mounting location, minimizing the need for laser head alignment. A diagram of the mounting location for this laser head is presented in Figure 3-16.

Optics

Plane of orientation with respect to laser head

The mounting plane tolerance of the optics to the laser head is the same as discussed in the paragraph titled “Mounting plane tolerance,” above. That is, the bottom or sides of the interferometers should be parallel to within $\pm 1^\circ$ of the plane defined by the laser head’s three mounting feet.

Effect of optics on measurement direction sense

The orientation and configuration of the interferometers affects the measurement direction sense. The direction sense depends on which frequency is in the measurement path of the interferometer. For example, if f_1 (lower frequency) is in the measurement path and f_2 (higher frequency) is in the reference path and the optics are moving away from each other, the fringe counts will be INCREASING. This corresponds to using an Agilent 5517A, Agilent 5517B, or Agilent 5517C Laser Head (mounting feet in horizontal plane) with an Agilent 10702A Linear Interferometer mounted with labels facing up and down (see Figure 3-5). Interchanging f_1 and f_2 (e.g., rotating interferometer 90°) in this example will result in the fringe counts DECREASING.

Optics

The optical schematics for the interferometers, in Chapter 7 “Measurement Optics,” show which frequency polarizations are in the measurement path.

DIRECTION SENSE

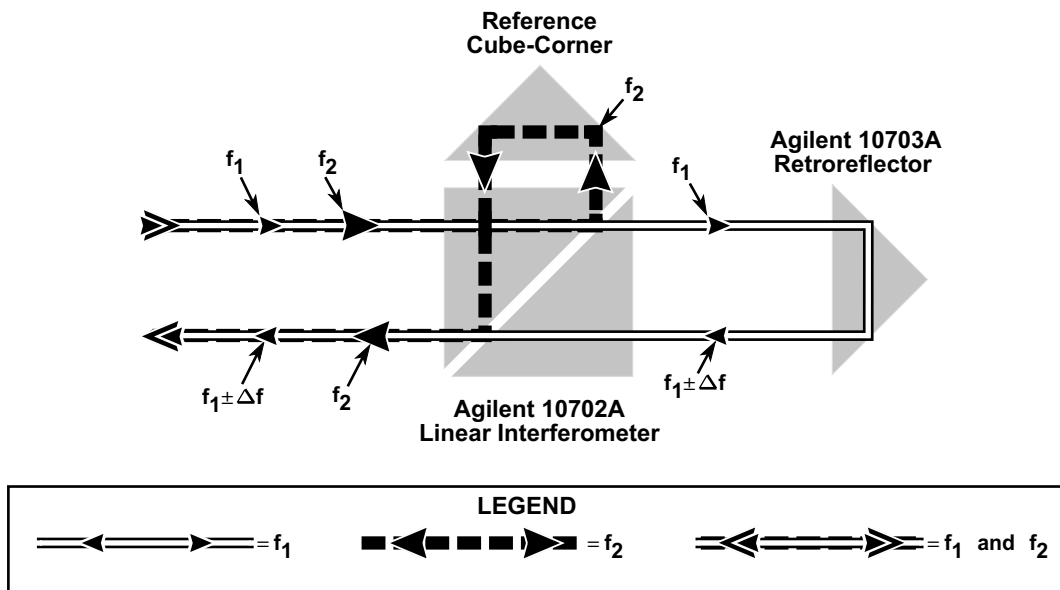

Figure 3-5. Direction sense - fringe counts increase as optics move apart

As with the laser heads, when the interferometers are rotated 90° , the measurement direction sense will change. This rotation causes switching of frequencies in the measurement path.

Configuration effects

Many of the distance-measuring interferometers can be configured to turn the beam at right angles. When configuring the linear, single-beam, and plane mirror interferometers to turn the beam, the measurement direction sense will be changed. This is because the measurement and reference paths are switched on the interferometers, therefore changing the direction sense. For more information, see the Chapter 7, “Measurement Optics,” in this manual.

Optics

Vibration isolation for optics

Vibration of the optics along the beam can cause the fringe count in the laser measurement system electronics to fluctuate rapidly. Vibrations along this axis constitute real, measurable, displacements; you will have to decide if these fluctuating measurements are acceptable in your application. In extreme cases, however, the velocity of the optics may momentarily exceed the velocity limitation of the laser system, causing an error.

When vibration occurs perpendicular to the beam, the beam signal power can fluctuate. If this fluctuation is too great, insufficient beam signal will arrive at the receivers, causing a “measurement signal error”.

Loose mounting can cause the optics to move inappropriately during a measurement, causing a measurement error or loss of beam power.

Elastic mounting can have the same effect as loose mounting. It can also be responsible for a “sag” offset in the optics’ positions. If there is vibration in the machine, an elastic mounting can transmit and amplify the vibration to the attached optic, possibly causing more errors. You should anticipate these effects and minimize them, if necessary, during the laser measurement system design process.

Certain interferometers are inherently less susceptible to vibration effects than others. This is particularly true of differential-style interferometers such as the Agilent 10715A, Agilent 10719A, and Agilent 10721A. The stability of these interferometers is due to the fact that both their reference beams and their measurement beams travel to external mirrors. Any motion of the interferometer itself that is common to both beams will not appear as a measurement. Of course, any vibration between the reference and measurement mirrors will constitute real, measurable, displacements.

Adjustable mounts for optics

The optical elements inside several of the Agilent laser measurement system optics are not precisely referenced to their housings. In most applications involving these optics, a few simple alignments during system installation can usually provide equal or better alignment than referencing the optics to their housings. Therefore, slight positioning adjustments of the unreferenced interferometers, beam splitters, and beam benders are needed for proper system alignment.

Optics

Positioning adjustments for most optics can be provided by using Agilent 10710B or Agilent 10711A Adjustable Mounts, as appropriate. These mounts allow adjustment of pitch and yaw of any attached optic. (Roll adjustment is typically not required, and can usually be avoided by careful optical system layout.)

For a listing of which Adjustable Mount supports which optic, see the Chapter 9, “Accessories,” in this manual.

In some applications, referenced housings can provide significant advantages. For example, the alignment requirements for certain multi-axis applications can be difficult or impossible to achieve without referenced housings. In those cases, interferometers such as the Agilent 10719A, Agilent 10721A, Agilent 10735A, and Agilent 10736A should be considered. These products have referenced housings and prealigned optical elements. Because they have individual mounting requirements, these products are not intended for use with the adjustable mounts described above. For more information about these optics, refer to Chapter 7, “Measurement Optics,” in this manual.

Fasteners for optics

Any optical component that fits an adjustable mount is supplied with mounting screws to mount it on the appropriate adjustable mount.

Vacuum applications

There are vacuum options for Agilent optical components, which are compatible with vacuum environments. Contact Agilent Call Center for information (telephone numbers of various call centers are listed on the “Service and Support” page at the back of this manual). The housings of these components are made of stainless steel and the optical elements are attached to these housings using a low volatility (space grade) adhesive. See the “Specifications” information for each optic for a list of materials used in the optic.

If the laser beam has to go through a window (for example into a vacuum chamber) the window must meet the following requirements:

1. A minimum window aperture of 25.4 mm (1 inch) with a minimum thickness of 8 mm (0.3 inch). If a larger window is used, it must be proportionally thicker to assure no distortion in the window when under differential pressures.
2. Transmitted wavefront distortion less than $\lambda/10$ (peak-valley, single-pass) over a 23 mm (0.9 inch) diameter.
3. Parallelism of faces less than ± 2 arc-minutes, to reduce beam steering.

Optics

4. Surface quality 60-40 or better, per Mil-0-13830.
5. The window must be strain-free.

Differential measurements with interferometers

Several interferometers have the capability to make differential measurements. A differential measurement is one in which both the reference beam and the measurement beam travel to external mirrors outside the interferometer housing. This allows measurement of the relative positions of the two external mirrors, either or both of which may be moving. Viewed another way, this allows measuring the motion of one reflector relative to a reference datum elsewhere in the machine, external to the interferometer itself. This is unlike the typical interferometer configuration because usually the reference beam path length does not change; in differential configurations, it can.

One useful example of a differential measurement in a lithography application is for measuring the motion of the X-Y stage relative to the optical column. The Agilent 10719A One-Axis Differential Interferometer (shown in Figure 7J-I of subchapter 7J) and the Agilent 10721A Two-Axis Differential Interferometer (shown in Figure 7K- 1 of subchapter 7K) are ideally suited to this type of measurement, because they provide parallel reference and measurement paths which are offset vertically by 19 mm (0.750 inch). For such an application, a user-supplied reference plane mirror is required in addition to the measurement reflector on the X-Y stage.

The Agilent 10715A interferometer (shown in Figure 7G-1) also permits differential measurements between two plane mirrors. However, instead of having an offset spacing as in the Agilent 10719A or Agilent 10721A, the Agilent 10715A permits the reference beams and the measurement beams to be aligned essentially coaxially. A specially-shaped reference plane mirror is supplied with the Agilent 10715A.

Customized differential configurations are possible with several other interferometers. However, considerable care should be exercised during design and layout to avoid introduction of alignment errors, thermal or mechanical instabilities, and potential deadpath problems. When making differential measurements, both reflectors (reference and measurement) should be of the same type (cube corner or plane mirror); this minimizes thermal drift problems with ambient temperature changes.

Optics

To use the Agilent 10702A, Agilent 10705A, or Agilent 10766A in a differential configuration, the reference cube corner can simply be detached from the interferometer housing and attached to the reference surface of interest. This is shown in Figure 7A-7. Be aware that all installation and alignment requirements for the measurement reflector now apply also to the reference reflector.

To use the Agilent 10706A or Agilent 10706B interferometer in a differential configuration, a plane mirror is recommended as the reference reflector. Simply replace the reference cube corner (or high-stability adapter) with the Agilent 10722A Plane Mirror Converter and attach the reference plane mirror to the reference surface of interest. This is shown in Figure 7C-4. Again, install and align the reference reflector the same as you would the measurement reflector.

Moving interferometer instead of reflector

When moving the interferometer instead of the measurement reflector is required, the Agilent 10702A-001 (or Agilent 10766A) should be used. In practice, for alignment reasons, these are the only interferometers (except the straightness interferometers) that can be moved while making measurements. For a detailed explanation of why this option is required, see Figure 7A-2.

Introducing an offset into the laser beam

There may be an occasion when you will want to simply introduce an offset into your laser beam, to get it from the laser head to the interferometer without having to relocate either one of them. Figure 3-6 shows two ways in which this can be done.

To simply translate the beam, you can use two reflectors (such as the Agilent 10726A Beam Bender) as a “periscope”, as shown in Figure 3-6(A). Changing the spacing between the reflectors, or rotating the device can change the amount of offset.

To reverse the direction of the beam, you can use two reflectors in a “retroreflector” arrangement as shown in Figure 3-6(B).

Beam Path Loss Computation

Multiaxis positioning systems must be designed to allow sufficient optical power to reach each Agilent 10780C, Agilent 10780F, Agilent E1708A, or Agilent E1709A Receiver in the system.

Since all optics have an efficiency of less than 100%, an optical power loss budget must be created as a part of any multiaxis system design. This chapter defines optical efficiency as it relates to the signal loss through components. A method for computing the optical power loss in a system is described.

Considerations

The following considerations are important in designing a reliable multiaxis measuring system:

- When using the Agilent 10780C/F or Agilent E1708A receivers, typically up to four measurement axes can be easily implemented without optical power loss imposing significant constraints. A system of five or six axes is usually feasible, although closer attention to the power loss budget is required. A system having more than six axes is possible under certain circumstances (with PC- or VME-based electronics), but the optical power loss budget quickly becomes the limiting constraint. The Agilent E1709A receiver was designed for systems that have more than six measurement axes.
- Minimum laser output power is 120 microwatts for the laser heads. The typical laser output power is about 400 microwatts. The output power is relatively constant over the life of the tube, and tends to drop off immediately at the end.
- Higher laser output power is available upon request.

Beam Path Loss Computation

INTRODUCING AN OFFSET

A: Offset Only

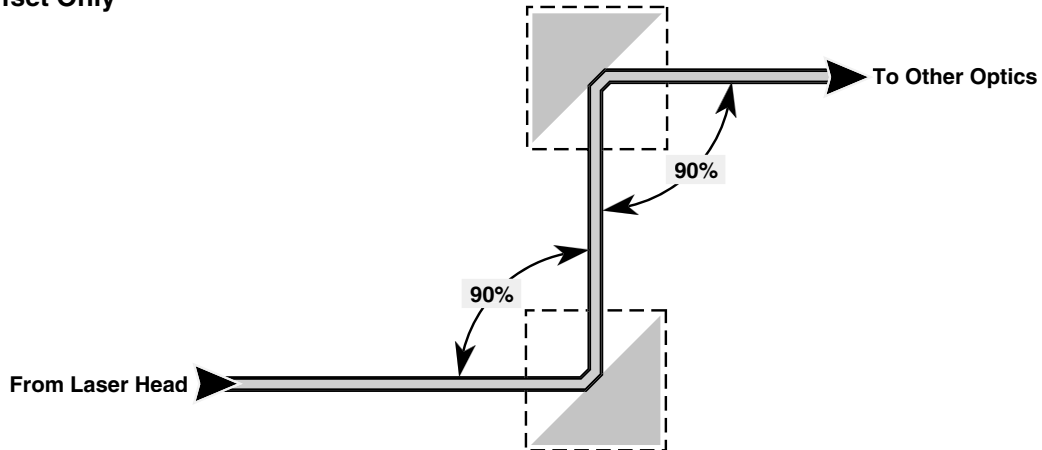

B: Offset Plus Direction Change

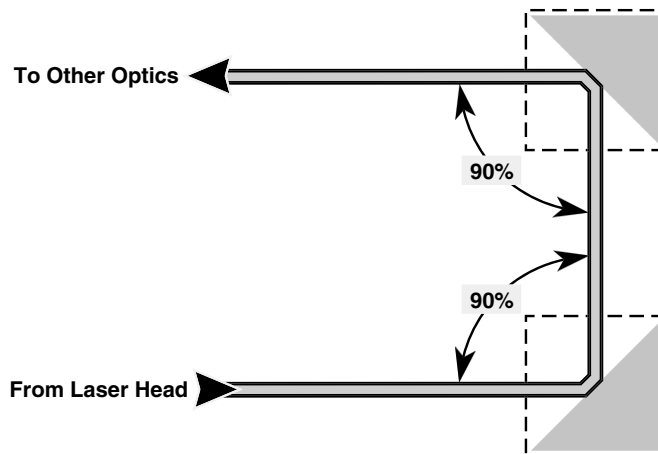

Figure 3-6. Introducing an offset into the laser beam

- Minimum required power at the Agilent 10780C Receiver is 1.5 microwatts. The Agilent 10780F Remote Receiver and Agilent E1708A Remote Dynamic Receiver require 2.2 microwatts with its standard 2-meter fiber-optic cable (more with longer cables). The Agilent E1709A Remote High-Performance Receiver requires a minimum of 0.20 to 0.80 microwatts, depending on the AC/DC ratio, with standard 2-meter plastic fiber-optic cable. (Adjustment of the receiver's gain is required to obtain this sensitivity. See the alignment and gain adjustment procedures in Chapter 8, "Receivers," of this manual.)

Beam Path Loss Computation

- The beam splitters have “worst-case” as well as “typical” transmission and reflection specifications. Refer to the paragraphs titled “Axis component efficiencies (worst case)” and “Axis component efficiencies (typical)” on the following pages, for these specifications.
- In addition, all optics have small reflection and absorption losses that occur at each internal interface or component, which is taken into account in their efficiency value.
- Fingerprints, dirt, or oil on a glass surface significantly reduce optical efficiency by increasing both reflection and absorption losses.
- System misalignment also reduces the amount of light reaching the receiver.
- Thermal gradients in the beam path can bend the beam and distort the wave front, both of which reduce optical signal strength at the receiver.

Calculation of signal loss

In order to assess the signal loss in a measurement system, each optical component has been characterized by both worst case and typical optical efficiencies. These efficiency values for each optical component are listed in the “Specifications” section for each optic (that is, the specifications section in Chapter 6, “Beam-Directing Optics,” for beam splitters and Chapter 7, “Measurement Optics,” for interferometers.)

Optical efficiency is defined as:

$$\text{Efficiency} = \frac{\text{Optical Power Out}}{\text{Optical Power In}}$$

The optical efficiencies for the interferometers are given with the respective measurement reflector efficiency included. For example, the Agilent 10702A Linear Interferometer efficiency includes the efficiency of the Agilent 10703A Retroreflector.

The combined optical efficiency of a given measurement axis is the product of the efficiencies of the individual optics in the beam path. This combined efficiency times the minimum laser output power in microwatts yields the worst case optical power at the receiver. This value must be at least 1.5 microwatts for the Agilent 10780C Receiver, or 2.2 microwatts for the Agilent 10780F Remote Receiver and Agilent E1708A Remote Dynamic Receiver, or 0.20 to 0.80 microwatts for Agilent E1709A Remote High-Performance Receiver. A beam power

Beam Path Loss Computation

safety factor of at least three is recommended even though worst case laser and optics are assumed. Creating a system with five or more axes of measurement may result in a beam power safety factor that is less than three.

As an example, consider a typical installation with two measurement axes and a Wavelength Tracker axis (Figure 7I-3). Assume differential interferometers, good optical alignment, 98% efficient plane mirrors (on the stage), comparable path lengths, and use of any Agilent laser head.

The three axes — X, Y, and Wavelength Tracker (WT) — have the components listed in the following table.

Axis component efficiencies (worst case)

Axis	Component	Component Efficiencies (Worst Case)
X	Agilent 10700A (67% path)	61%
X	Agilent 10701A	39%
X	Agilent 10715A	25%
Y	Agilent 10700A (67% path)	61%
Y	Agilent 10701A	39%
Y	Agilent 10715A	25%
W	Agilent 10700A (33% path)	27%
W	Agilent 10707A	98%
W	Agilent 10717A	25%

Assuming a minimum laser power of 120 microwatts, you can calculate the worst-case power at the X, Y, and Wavelength Tracker receivers by multiplying the product of component efficiencies by the laser output power:

$$\text{Power at X} = 0.61 \times 0.39 \times 0.25 \times 120 = 7.1$$

$$\text{Power at Y} = 0.61 \times 0.39 \times 0.25 \times 120 = 7.1$$

$$\text{Power at WT} = 0.27 \times 0.98 \times 0.25 \times 120 = 7.9$$

This system has a power safety factor of 4.7 at worst case (based on use of the Agilent 10780C Receiver, which requires 1.5 microwatts) for each axis resulting in reliable operation and easy alignment.

Beam Path Loss Computation

You can also calculate this safety factor using the typical optical efficiency values, listed in the following table.

Axis component efficiencies (typical)

Axis	Component	Component Efficiencies (Typical)
X	Agilent 10700A (67% path)	63%
X	Agilent 10701A	45%
X	Agilent 10715A	36%
Y	Agilent 10700A (67% path)	63%
Y	Agilent 10701A	45%
Y	Agilent 10715A	36%
W	Agilent 10700A (33% path)	30%
W	Agilent 10707A	99%
W	Agilent 10717A	36%

Using the typical laser power of 400 microwatts, you can calculate the typical power at the X, Y, and Wavelength Tracker receivers by multiplying the product of each component efficiency by the laser output power for each axis.

$$\text{Power at X} = 0.63 \times 0.45 \times 0.36 \times 400 = 40.8$$

$$\text{Power at Y} = 0.63 \times 0.45 \times 0.36 \times 400 = 40.8$$

$$\text{Power at WT} = 0.30 \times 0.99 \times 0.36 \times 400 = 42.8$$

By using the typical efficiencies of the component, a safety factor greater than 28 is achieved (based on use of the Agilent 10780C Receiver, which requires 1.5 microwatts). The Agilent 10780F (2.2 microwatts), Agilent E1708A (2.2 microwatts), and Agilent E1709A (0.20 to 0.80 microwatts) receivers are more sensitive. Hence, can operate with more axes.

Receivers

General

When determining the receiver mounting locations and positions, keep the following points in mind:

1. At a 45° position (roll), the signal will go to zero.
2. The receiver typically dissipates 2.0 Watts, with a maximum dissipation of 2.7 Watts. Plastic pads keep an air gap around the receiver and act as thermal and electrical isolators.

CAUTION

Use nylon screws only (Agilent 2360-0369). The receiver housing must be electrically isolated from the mounting fixture.

3. The remote sensor in the Agilent 10780F Remote Receiver, Agilent E1708A Remote Dynamic Receiver, and Agilent E1709A Remoter High-Performance Receiver does not dissipate any power. The remote sensor does not require a nylon screw.
4. Allow a 5 cm space at the rear of each receiver housing for each cable connection.
5. The fiber-optic sensor head of the Agilent 10780F, E1708A, and E1709A receivers may be mounted directly to certain interferometers (Agilent 10719A, Agilent 10721A, Agilent 10735A, Agilent 10736A, Agilent 10737L, R). Alignment pins are provided for easy installation and alignment. This eliminates the need for any other user-supplied mount for the sensor head.
6. Maintain a bend radius not less than 35 mm (1.4 inches) to prevent signal attenuation in the receiver's fiber optic cable.

Clearance for laser beam

Figure 8-2 shows the Agilent 10780C and Agilent 10780F receivers and the proper beam spacing.

Alignment adjustment required

The Agilent 10780C, Agilent 10780F, Agilent E1708A, or Agilent E1709A receiver requires an alignment relative to the input beam to maximize measurement signal strength. See the alignment and gain adjustment procedures in Chapter 8, "Receivers," of this manual.

Example Configurations

Single-axis system for servo-track writing

Figure 3-7 shows a single-axis system to control servo-track writing. This system uses one each of:

- Agilent 5517A, 5517B, or 5517C Laser Head
- laser head cable
 - Use an Agilent N1251A/B High Performance Laser Head Cable to connect to Agilent 10895A, Agilent 10897B, or Agilent 10898A VME electronic boards.
 - Use an Agilent 10881A/B/C Laser Head Cable to connect to Agilent 10885A, Agilent 10889B, or Agilent N1231A PC-compatible electronics.
- Agilent 10705A Single Beam Interferometer
- Agilent 10704A Reflector
- Agilent 10780C Receiver
- Agilent 10790A Receiver Cable
 - Use an Agilent 10790A/B/C Receiver Cable to connect to Agilent 10895A, Agilent 10897B, or Agilent 10898A VME electronic boards.
 - Use an Agilent 10880A/B/C Receiver Cable to connect to Agilent 10885A PC-compatible electronics.
- Agilent laser axis of measurement electronics (Agilent 10885A, 10897B, or 10898A)

SINGLE-AXIS SYSTEM

Figure 3-7. Single-axis system for servo-track writing

Multiaxis configurations

The maximum number of independent axes of displacement that can be measured using one laser head depends on: 1) the measurement system electronics, 2) the strength of the beam from the laser head, and 3) the sensitivity of the receivers used.

By using the proper combination of beam splitters, beam benders, and interferometers, the measurement axes can be established with a minimum number of components. The following paragraphs provide examples of routing the laser beam for multiaxis measurement configurations.

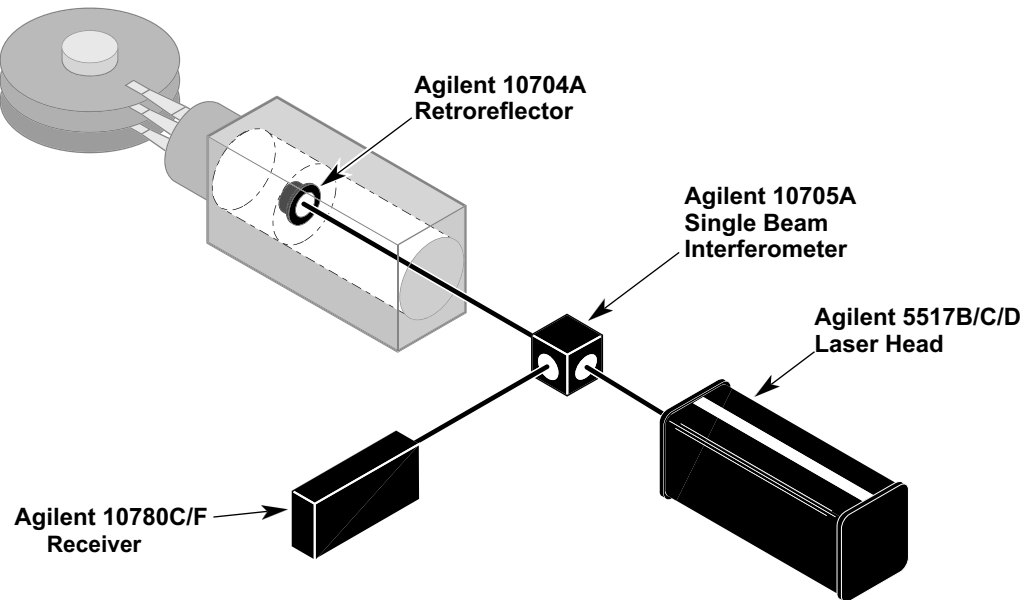
Example Configurations

Multiaxis system for a precision x-y stage

Figure 3-8 shows a multiaxis system for a precision X-Y stage. This system uses:

- one Agilent 5517C Laser Head
- one laser head cable
 - Use an Agilent N1251A/B High Performance Laser Head Cable to connect to Agilent 10895A, Agilent 10897B, or Agilent 10898A VME electronic boards.
 - Use an Agilent 10881A/B/C Laser Head Cable to connect to Agilent 10885A, Agilent 10889B, or Agilent N1231A PC-compatible electronics.

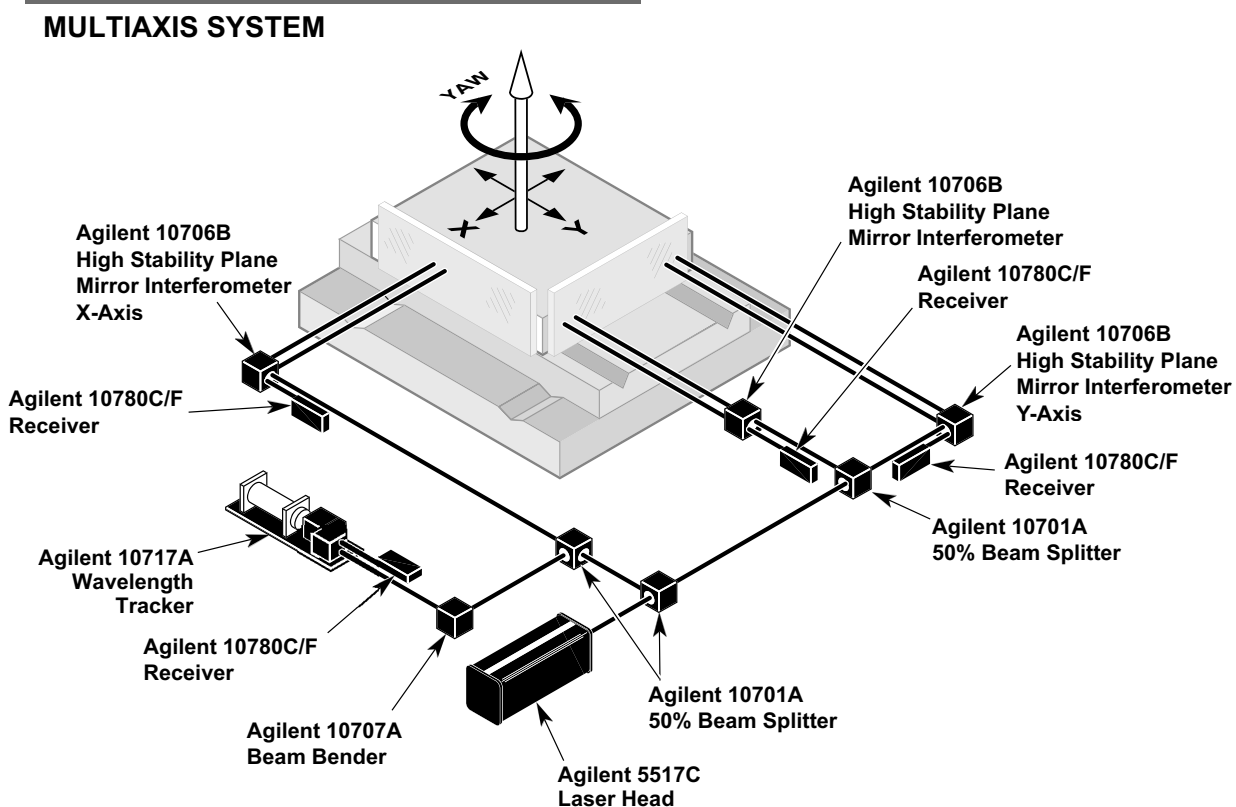

Figure 3-8. Multiaxis system for a precision x-y stage

- three Agilent 10701A 50% Beam splitters
- three Agilent 10706B High Stability Plane Mirror interferometers
- one Agilent 10707A Beam Bender

Example Configurations

- one Agilent 10717A Wavelength Tracker
- four Agilent 10780F Remote receivers
- four receiver cables
 - Use Agilent 10790A/B/C Receiver cables to connect to Agilent 10898A, Agilent 10897B, or Agilent 10895A VME electronic boards.
 - Use Agilent 10880A/B/C Receiver cables to connect to Agilent 10885A PC-compatible electronics.
- four Agilent 10710B Optics mounts
- three Agilent 10711A Optics mounts
- three Agilent laser axis of measurement electronics (Agilent 10885A, Agilent 10889B, Agilent 10895A, Agilent 10897B, Agilent 10898A, or Agilent N1231A)

NOTE

The Agilent 10751A, Agilent 10751B, Agilent 10757A, Agilent 10757B, or Agilent 10757C cannot be used with the Agilent 10885A PC-compatible electronics, because the Agilent 10885A does not provide compensation calculation capability.

- one Agilent Automatic Compensation Board

Four-axis linear configuration

Figure 3-9 shows a four-axis measurement configuration with all components aligned in one plane. Note that any of the components (beam benders, beam splitters, or interferometers) could be rotated in 90° increments to provide a three-dimensional configuration. Since interferometers can also bend the laser beam through 90°, the number of components can be minimized.

NOTE

In an application where the Agilent 10702A Linear Interferometer is the moving component and the Agilent 10703A Retroreflector is the fixed reference, the Agilent 10702A Linear Interferometer-001 must be used to eliminate alignment errors. If a right-angle beam bend is made through the Agilent 10702A, it must be the fixed component. When the Agilent 10705A Single Beam Interferometer is used, it must be the fixed component.

Example Configurations

FOUR-AXIS CONFIGURATION

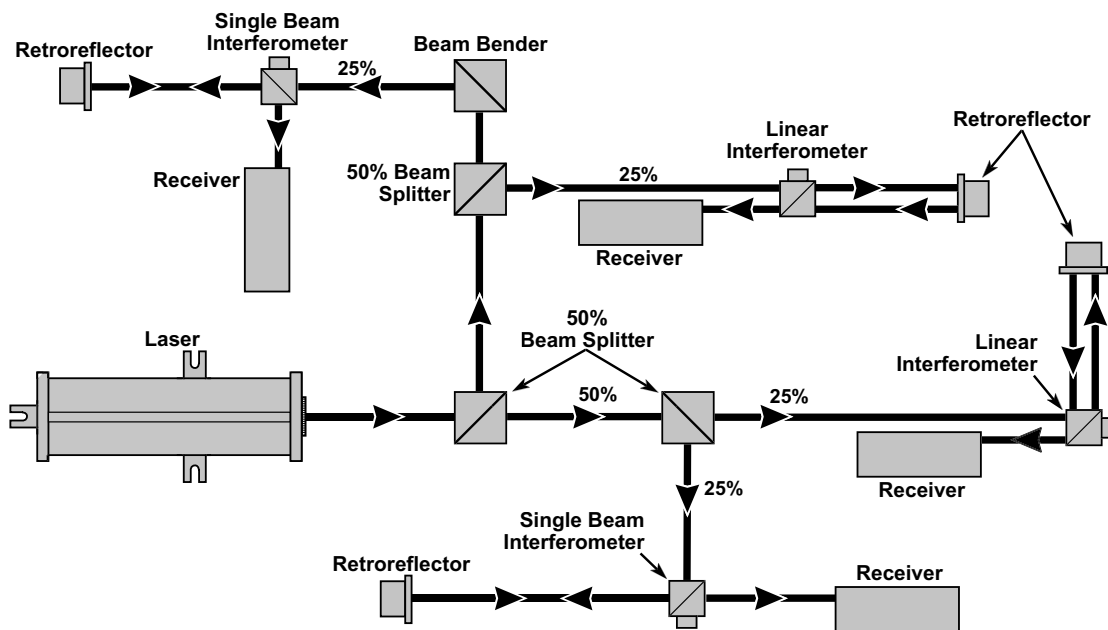

Figure 3-9. Four-axis configuration

Two-axis plane mirror

Figure 3-10 shows an X-Y stage measurement configuration using the Agilent 10706B High Stability Plane Mirror Interferometer. The X-Y stage has plane mirrors mounted at 90° to each other; these are the reflectors for the plane mirror interferometers. The advantages of this configuration are discussed in Chapter 15, “Accuracy and Repeatability,” of this manual. The Agilent 10706A Plane Mirror Interferometer is used to bend the laser beam.

Two-axis plane mirror in a vacuum

In an application where the X-Y stage is installed in a vacuum chamber, the configuration in Figure 3-10 may not be suitable. Figure 3-11 shows a configuration using the Agilent 10567A Dual Beam Beam-Splitter which allows the laser beam to enter and exit the chamber through one window. This allows the receivers to remain outside the chamber and leaves only the optics inside. For window specifications, refer to the “Vacuum Applications” subsection under the “Optics” section of Chapter 3, “System Design Considerations,” in this manual. If the Agilent 10567A is not used, two windows (and possibly additional beam splitters and benders) will be required.

Example Configurations

TWO-AXIS PLANE MIRROR INTERFEROMETER CONFIGURATION

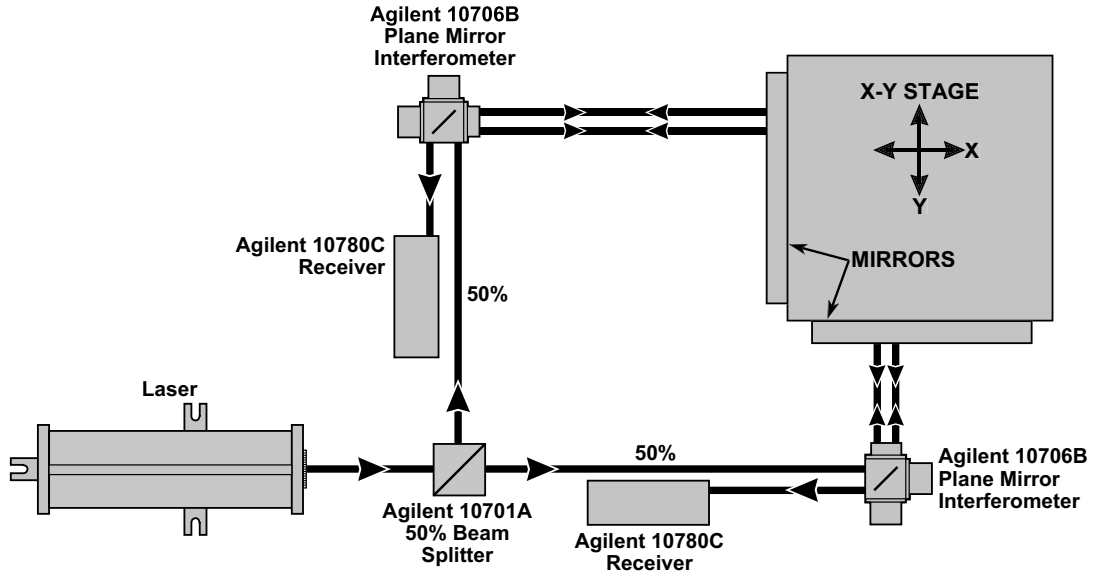

Figure 3-10. Two-axis plane mirror interferometer configuration

X-Y STAGE INSTALLED IN A VACUUM CHAMBER

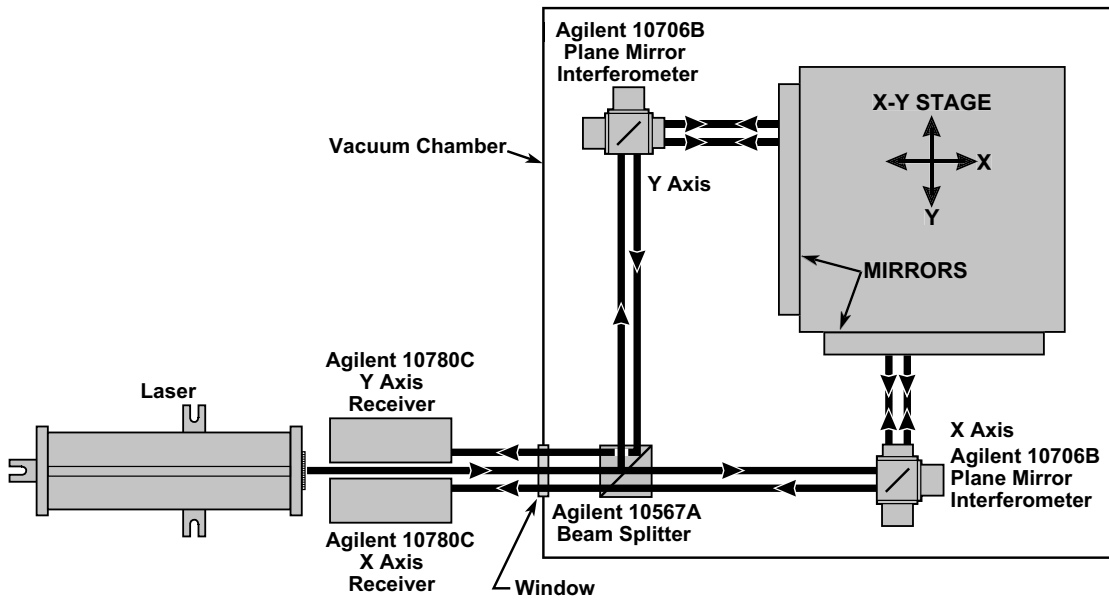

Figure 3-11. X-Y stage installed in a vacuum chamber

Example Configurations

Two-axis measurement system using two Agilent 10715A differential interferometers

In X-Y stage applications where maximum measurement accuracy and stability are required, the Agilent 10715A Differential Interferometer can be used instead of the Agilent 10706A/B Plane Mirror Interferometer. In Figure 3-12, an X-Y stage using Agilent 10715A's is illustrated. As with plane mirror interferometers, the reflectors are plane mirrors mounted at 90° to each other on the stage.

Using the Agilent 10715A Differential Interferometer also requires mounting the reference mirror (supplied with the Agilent 10715) between the interferometer and measurement reflector. Mounting instructions for the reference mirror are given later in this chapter.

The Agilent 10715A-001 interferometer turns the beam as shown in Figure 3-12. This configuration requires use of opposite input apertures for each interferometer, resulting in reversed direction senses for the X and Y axes. The reversed direction sense must be corrected in the electronics or by software. Note that the receiver for each axis is above the input beam.

Three-axis measurement system using discrete plane mirror interferometers (X, Y, YAW)

Some X-Y stage applications require measurement or control of the stage yaw. Yaw is angular rotation of the stage about an axis (the Z-axis) perpendicular to the plane of the stage. With two interferometers on one axis of the stage, angular motion can be calculated. Figure 3-13, the yaw angle, THETA, is measured using axes Y and Y', and is calculated as follows:

$$\text{THETA} = \arctan\left(\frac{Y - Y'}{D}\right)$$

Example Configurations

TWO-AXIS MEASUREMENT SYSTEM

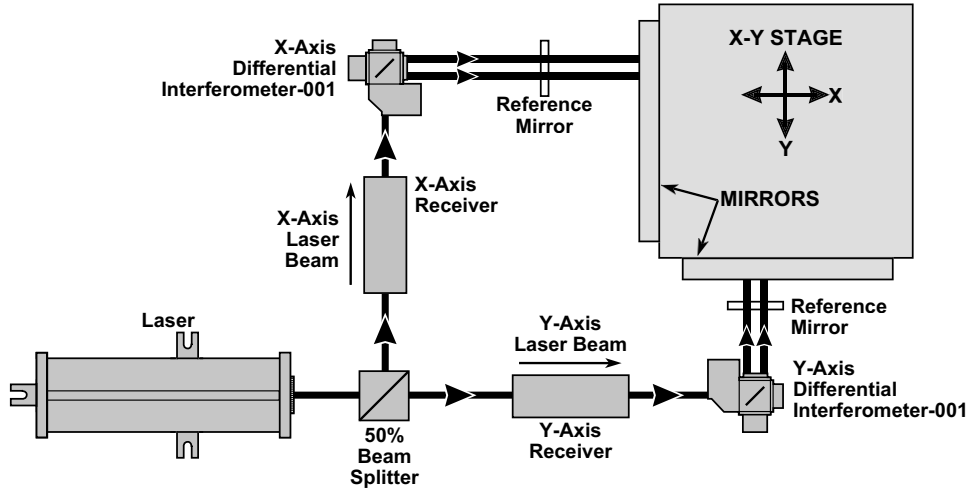

Note: Beam from laser passes under the receivers. The return beams return to the receivers after being offset in the interferometers.

Figure 3-12. Two-axis system using two Agilent 10715A differential interferometers

YAW MEASUREMENT OF X-Y STAGE

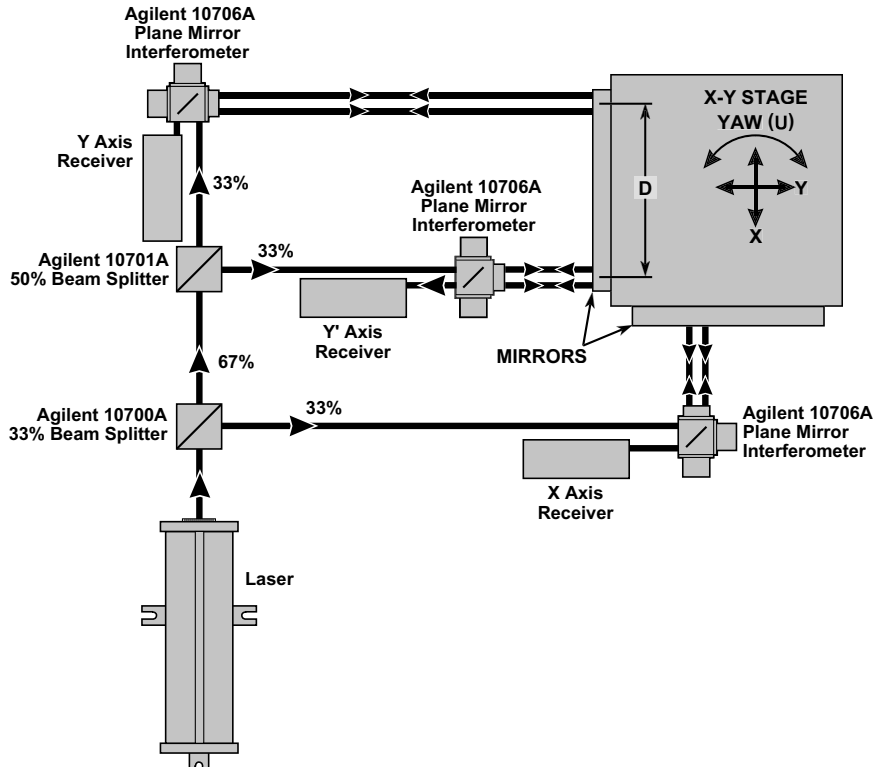

Figure 3-13. Yaw measurement of x-y stage using discrete plane mirror interferometers

Example Configurations

The resulting angular measurement will only be as accurate as the measurement distance, “D”. However, even if “D” is not known precisely, this technique can provide extremely high-resolution or relative angular changes.

The resolution depends on “D”, and— with electronic resolution extension—can be well under 0.01 arc-seconds. For applications in which the stage is servo-controlled to its initial angle (THETA = 0), this high resolution is the key measurement consideration and the accuracy of D is not critical.

For applications in which accuracy and resolution are both critical, D may be determined precisely by rotating the stage through a known angle (“THETA”) and solving the above equation for D.

When installing this type of yaw-measuring system, take care to ensure the parallelism of the adjacent linear measurements to minimize cosine errors.

Angular rotation of the measurement mirror is limited to the “Alignment Requirement-vs-Distance” value for the interferometer used. See the “Specifications” section of subchapter 7C (Plane Mirror Interferometer) in this manual.

When yaw control of a stage must be done at high speeds using a closed-loop control system, the (Y-Y’) value needs to be obtained quickly. If the difference is calculated in software in the controller, it may be too slow. There are two methods to achieve a high-speed (Y-Y’) output:

- Electronically
- Optically

Electronic yaw calculation method

This difference calculation can be done in hardware for both the Y and the Y’ axes. A custom servo board could be designed to accept position information from both Y and Y’ and perform a fast angular calculation, yielding an input for the yaw servo. See the appropriate electronics documentation for servo-loop interfacing.

Optical yaw calculation method

There are optical configurations that will allow direct output of the difference between Y and Y’, for example on the Y’ axis receiver. This is shown in Figures 3-14 and 3-15, both using the Agilent 10706A Plane Mirror Interferometer.

OPTICAL METHOD FOR YAW MEASUREMENT

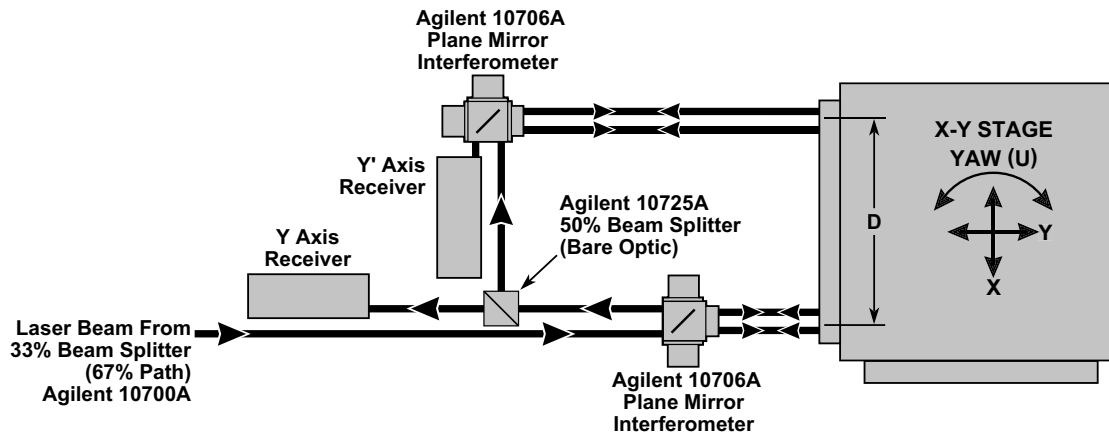

Figure 3-14. Optical Method for Yaw Measurement

OPTICAL METHOD FOR YAW MEASUREMENT

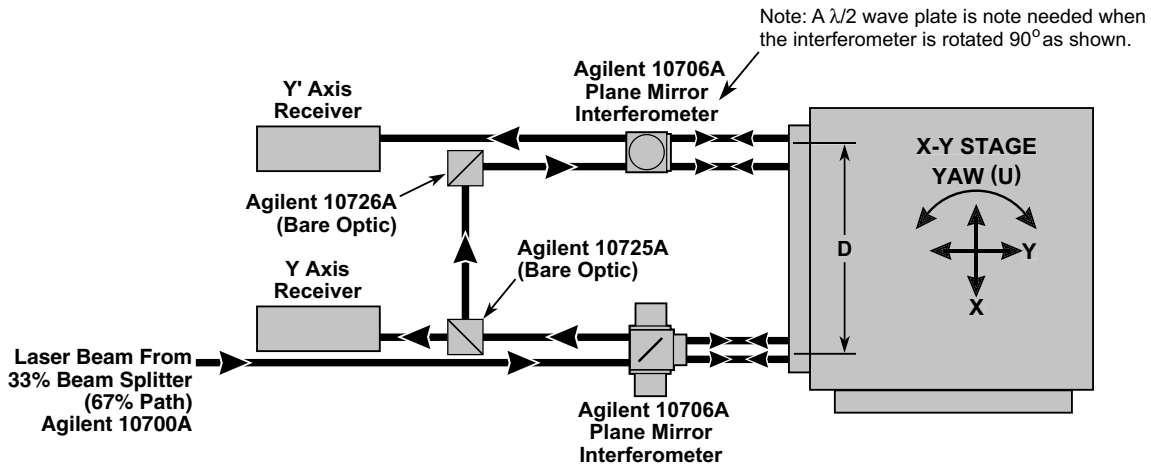

Figure 3-15. Optical Method for Yaw Measurement

Similar techniques can be used with the Agilent 10715A Differential Interferometer. This is done by splitting off part of the Y-axis combined measurement signal (after going completely through the interferometer) and using this as the input beam to the Y' axis interferometer. This technique outputs (Y-Y') information directly on the Y'-axis receiver.

Optical Device Troubleshooting

Both of these optical configurations require some special optical components not available through Agilent Technologies. In both figures, a small 50% non-polarizing beam splitter is required. This beam splitter must be very small to avoid blocking or clipping the adjacent beam. This is also true for the beam bender required in the configuration shown in Figure 3-15.

Multiaxis systems using Agilent 10719A and Agilent 10721A inteferometers

Multiaxis systems using Agilent 10719A and Agilent 10721A interferometers are described in subchapter 7J, “Agilent 10719A One-Axis Interferometer,” of this manual.

Multiaxis systems using Agilent 10735A and Agilent 10736A three-axis inteferometers

Multiaxis systems using Agilent 10735A and Agilent 10736A interferometers are described in subchapter 7N, “Agilent 10735A, 10736A, and 10736A-001 Three-Axis Interferometers,” of this manual.

Optical Device Troubleshooting

Problems with the optical devices are usually caused by their misalignment. Refer to the alignment procedures in Chapter 4, “System Installation and Alignment,” of this manual for further information.

Air turbulence caused by ventilation equipment or temperature gradients near the laser beam path can also cause measurement problems. If this is suspected, shield the area around the laser beam and optical devices with cardboard tubing, plastic sheet, or other suitable material. Some problems with sporadic counting and drift can be traced to air turbulence around the measurement path. This should be considered as a possibility before troubleshooting other parts of the system.

The Agilent 10735A and Agilent 10736A interferometers are designed to use a 9-mm (nominal diameter) laser beam.

The required 9-mm beam is available from an Agilent 5517C-009 laser head. The laser tube in this laser head is referenced to the base of the laser head. The laser head base is different from that of the standard Agilent 5517C Laser Head, and requires a special mounting site configuration, as shown in Figure 3-16.

Site Preparation

The standard Agilent beam-directing optics are designed for use with a 6-mm (maximum nominal diameter) laser beam. For use in 9-mm installations, Agilent offers the Agilent 10725A 9-mm Laser Beam Splitter and the Agilent 10726A 9-mm Laser Beam Bender. These two optical devices do not include mounting hardware. The 9-mm laser measurement system user, designer, or installer, must devise a mounting method that will hold the required optics in position without causing stress that may distort the optic.

The recommended receiver for 9 mm work is an Agilent 10780F Remote Receiver with a 9-mm lens on the fiber optic cable input. If you have an Agilent 10780F Remote Receiver with a 6-mm lens, you can order a 9-mm Replacement Lens Kit Assembly (Agilent part number 10780-67003) and a 9-mm Alignment Target (Agilent part number 10780-40009). The 9-mm lens can be used with any laser beam having a smaller diameter. The 9-mm lens can replace the 6-mm lens, if replacement becomes necessary; be sure to order the 9-mm Alignment Target, also.

The standard Agilent 10780C input aperture is designed for use with a 6-mm laser beam, so it is not recommended for use in a 9-mm laser system.

Site Preparation

Site preparation for laser head

Generally, Agilent laser heads require no special site preparation other than providing appropriate mounting holes. The Agilent 5517C-009 Laser Head's laser beam output is referenced to locations on its base. You can install this laser head simply by providing appropriate mounting holes, or you can create a specially prepared site to take advantage of its referenced output capability; specifications for a site for this latter use are given in Figure 3-16.

Site preparation for optical devices

Beam Benders such as the Agilent 10726A are used to create the laser path from the laser head to the interferometer. The Agilent 10726A Beam Benders are supplied by Agilent without mounting hardware. When you attach these optical pieces to their mounting hardware, use an attachment method that will not damage or distort them.

Site Preparation

For information about	See subchapter
Agilent 10719A One-Axis Differential Interferometer	7I
Agilent 10721A Two-Axis Differential Interferometer	7J
Agilent 10735A Three-Axis Interferometer	7N
Agilent 10736A Three-Axis Interferometer	7N
Agilent 10736A Option 001 Three-Axis Interferometer with Beam Bender	7N

The optics in a “referenced” interferometer are referenced to points on the outside of the case., This allows the interferometer to be installed in a predefined position and minimizes any alignment required with, respect to the measurement mirror(s) used with it.

Refer to Chapter 7, “Measurement Optics,” in this manual for information that can help you design the mounting location for an Agilent “referenced” interferometer.

Product specifications and descriptions in this document subject to change without notice.
 Copyright (C) 2002 Agilent Technologies
 Printed in U.S.A. 07/02
 This is a chapter from the manual titled:
 Laser and Optics User's Manual
 For complete manual, order:
 Paper version: p/n 05517-90045
 CD version: p/n 05517-90063
 This chapter is p/n 05517-90103



Artisan Technology Group is your source for quality new and certified-used/pre-owned equipment

- FAST SHIPPING AND DELIVERY
- TENS OF THOUSANDS OF IN-STOCK ITEMS
- EQUIPMENT DEMOS
- HUNDREDS OF MANUFACTURERS SUPPORTED
- LEASING/MONTHLY RENTALS
- ITAR CERTIFIED SECURE ASSET SOLUTIONS

SERVICE CENTER REPAIRS

Experienced engineers and technicians on staff at our full-service, in-house repair center

*InstraView*SM REMOTE INSPECTION

Remotely inspect equipment before purchasing with our interactive website at www.instraview.com ↗

WE BUY USED EQUIPMENT

Sell your excess, underutilized, and idle used equipment. We also offer credit for buy-backs and trade-ins. www.artisanng.com/WeBuyEquipment ↗

LOOKING FOR MORE INFORMATION?

Visit us on the web at www.artisanng.com ↗ for more information on price quotations, drivers, technical specifications, manuals, and documentation

Contact us: (888) 88-SOURCE | sales@artisanng.com | www.artisanng.com