

# M395

12/16-bit DAC M-module  
with 16x Voltage Outputs



The M395 features 16 analog voltage outputs, integrated on the ANSI certified M-module standard. The digital-to-analog converters have a resolution of 12 or 16-bit.

The voltage outputs on the M395 have a software programmable common output range of 0..+10V (uni-polar) or -10V..+10V (bi-polar).

The hosting system has full control of the M395 by accessing its dual-ported memory. Each channel has its own conversion register and an output will be updated when a new value is written in the corresponding register.

The local TMS320C203 DSP is capable of executing custom algorithms for optional signal processing.

- 16 DACs with 12 or 16-bit resolution
- Simultaneously updating voltage outputs
- Software programmable common output range (0..+10V or -10V..+10V)
- 10 microseconds (max.) output response time
- No potentiometers
- Analog front-end optically isolated
- Optional onboard DC/DC converter for isolated power supply
- Features local TMS320C203 DSP
- Calibration data stored in local EEPROM
- A08/D16 M-module interface



AcQquisition Technology B.V.

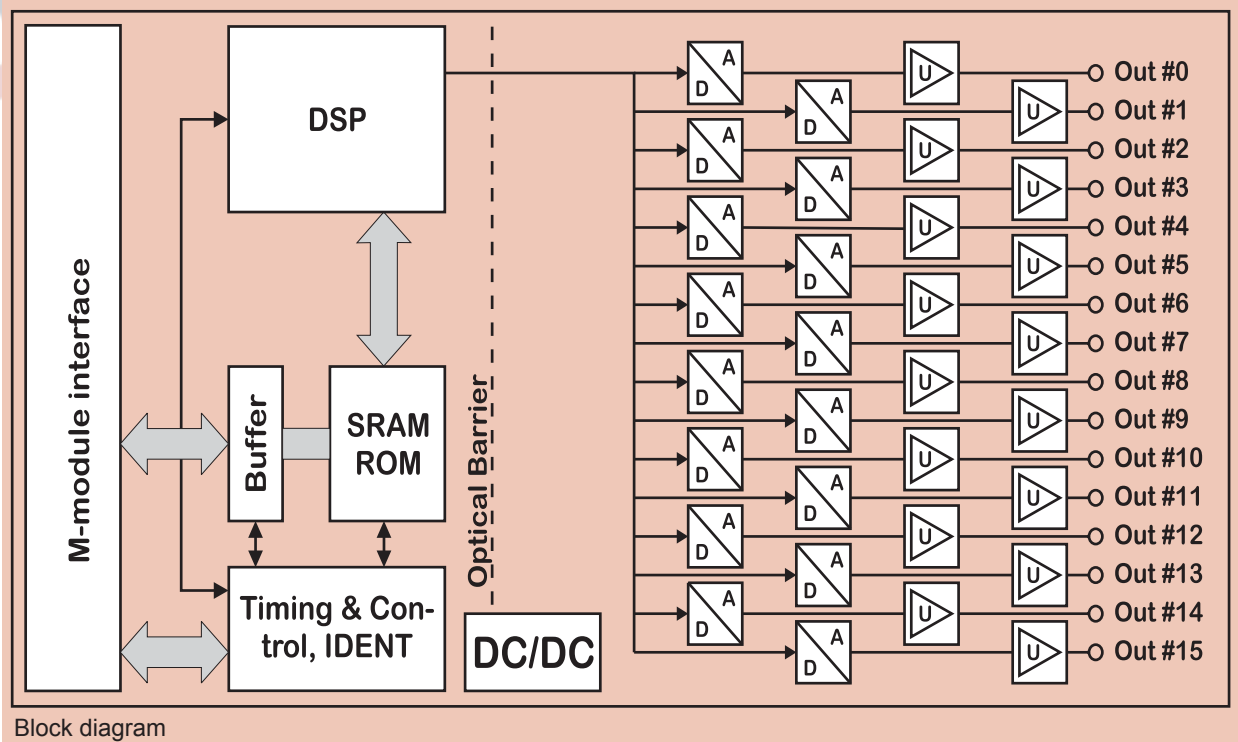

### M-module Compliancy

- A08/D16 (8-bit address and 16-bit data)
- INTA (software-end-of-interrupt)
- IDENT (identification EEPROM)

### DACs

- DAC resolution 12-bit or 16-bit
- Each channel has a dedicated data register that controls the output
- Output is updated after data register contents is refreshed
- Additional functionality can be implemented on request

### Analog Outputs

- 16 common-mode voltage output channels available
- Uni-polar and bi-polar output range software programmable for all channels
- Outputs are optically isolated from the system
- Features pre-loading and simultaneous output update for all channels

### Output Range

- Voltage outputs:
  - uni-polar (0..+10V)
  - bi-polar (-10V..+10V)

### Ordering Information

- M395/V12/NDC  
12-bit M-module, without DCDC
- M395/V12/WDC  
12-bit M-module, with DCDC
- M395/V16/NDC  
16-bit M-module, without DCDC
- M395/V16/WDC  
16-bit M-module, with DCDC
- M395/SW  
APIS based software
- M395/MAN  
M395 manual on paper

AcQquisition Technology B.V.

P.O. Box 627  
5340 AP OSS  
The Netherlands



Tel: +31-412-651055  
Fax: +31-412-651050  
Email: [info@acq.nl](mailto:info@acq.nl)  
URL: <http://www.acq.nl>