



Artisan Technology Group is your source for quality new and certified-used/pre-owned equipment

- FAST SHIPPING AND DELIVERY
- TENS OF THOUSANDS OF IN-STOCK ITEMS
- EQUIPMENT DEMOS
- HUNDREDS OF MANUFACTURERS SUPPORTED
- LEASING/MONTHLY RENTALS
- ITAR CERTIFIED SECURE ASSET SOLUTIONS

SERVICE CENTER REPAIRS

Experienced engineers and technicians on staff at our full-service, in-house repair center

*InstraView*SM REMOTE INSPECTION

Remotely inspect equipment before purchasing with our interactive website at www.instraview.com ↗

WE BUY USED EQUIPMENT

Sell your excess, underutilized, and idle used equipment. We also offer credit for buy-backs and trade-ins. www.artisanng.com/WeBuyEquipment ↗

LOOKING FOR MORE INFORMATION?

Visit us on the web at www.artisanng.com ↗ for more information on price quotations, drivers, technical specifications, manuals, and documentation

Contact us: (888) 88-SOURCE | sales@artisanng.com | www.artisanng.com

Operating Manual WA-1100 and WA-1600 Wavemeter®

08115-M-00 (Rev. E)



Copyright © EXFO Burleigh Products Group Inc. 2002
All Rights Reserved

Wavemeter is a registered trademark of Burleigh Instruments, Inc., an EXFO company.

Table of Contents

Table of Contents	i
Assumptions	ii
1. Introduction	1-1
Overview.....	1-1
Safety Considerations.....	1-2
Unpacking & Inspection.....	1-2
Setup	1-3
Fiber End Cleaning	1-3
Cleaning a Fiber Optic Connector.....	1-4
Cleaning a Universal Connector.....	1-4
Fan Filter Cleaning	1-5
2. Front Panel Communications	2-1
Front Panel Controls.....	2-1
Using the Front Panel Controls	2-2
Change Screens.....	2-2
Change Parameter Values	2-2
Save Parameter Values.....	2-2
Restore Saved Parameter Values	2-3
Display Screens.....	2-3
Setup Screens	2-5
3. Remote Communications	3-1
Overview.....	3-1
GPIB System Controller Settings.....	3-1
SCPI Communications Scheme	3-2
SCPI Command Detail	3-6
Common Commands	3-6
Measurement Instructions	3-9
CALCulate Subsystem	3-11
DISPlay Subsystem	3-14
SENSe Subsystem	3-16
STATus Subsystem.....	3-19
SYSTem Subsystem	3-21
TRIGger Subsystem.....	3-22
UNIT Subsystem	3-23
4. Theory of Operation & Calibration	4-1
Operating Principles	4-1
Accuracy.....	4-2

Accuracy Verification.....	4-6
Calibration	4-6
Appendix A. Specifications & Labeling	A-1
Dimensional Drawing	A-2
Rack Mounting Option.....	A-2
Appendix B. Warranty & Service	B-1
Warranty.....	B-1
Service	B-1
Appendix C. Error & Status Messages	C-1
Error Messages	C-2
Status Messages.....	C-3
Appendix D. Rear Panel Controls	D-1
GPIB Port	D-1
RS-232 Serial Interface Connector	D-2
Signal Monitor Connector.....	D-3

Declaration of Conformity

Assumptions

This Operating Manual provides information for individuals who use the WA-1100 and WA-1600.

Unless specifically stated, the information in this manual applies to both the WA-1100 and WA-1600.

This manual assumes familiarity with communication software and hardware interfaces with an IBM, or compatible, personal computer.

1. Introduction

This section provides general information on the WA-1100/1600 and information on unpacking and setting up the instrument.

Overview

WA-1100 and WA-1600 Wavemeter systems are instruments designed for simple, automatic and accurate wavelength measurement of continuous wave (CW) laser sources. Wavemeter systems count interference fringes produced by the input laser radiation in a scanning Michelson interferometer and simultaneously count fringes from a built-in reference laser. The ratio of the fringe counts of the input laser and the reference laser provides the wavelength of the input laser.

The accuracy of the measured wavelength is dependent on the knowledge of the reference laser wavelength. The WA-1100 uses a multi-mode HeNe reference laser with an absolute wavelength accurate to within ± 500 MHz or ± 1 part per million. The WA-1600 uses a stabilized single frequency HeNe laser that is calibrated to an accuracy better than ± 50 MHz relative to the Ne²⁰ atomic line center. This corresponds to a reference accuracy of ± 0.1 parts per million. Refer to Appendix A for complete specifications.

The WA-1100 and WA-1600 contain a rigid monolithic interferometer made from a single piece of aluminum and housed in a compact and rugged package. This design permits these instruments to be less susceptible to misalignment, more robust, faster and less expensive than the previous generation of WA-1100/1600 and competitive instruments.

Both the WA-1100 and WA-1600 products have microprocessor based electronics that allow accurate counting and analysis of interference fringes. The microprocessor computation automatically corrects for the refractive index of air, using data from built-in temperature and pressure sensors and converts the resulting measurement to units of nm, cm⁻¹ or GHz. The microprocessor also makes it possible for the instrument to calculate and display the deviation between the measured wavelength and starting point, or compute the average of up to 128 measurements. Refer to Section 4 for additional information on the theory of operation.

Introduce laser light into the instrument by attaching your fiber optic cable to the fiber optic connector on the front of the Instrument. The standard connector is FC/PC. An FC/APC connector is available as an option at the time of order.

The ifront panel has controls to review data and review and change parameter values. Refer to Section 2 for information on the controls and display and setup screens.

The instrument has a built-in bi-directional RS-232 interface and a GPIB interface for transmitting data and remotely controlling the instrument. Refer to Section 3 for information on these interfaces and the SCPI communication scheme.

The Monitor port on the back of the instrument provides access to the interferometer fringe signals and timing signals that govern the wavelength measurement. Refer to Appendix D for further information.

Safety Considerations

This product has been designed, manufactured and tested in accordance with EC Standard EN61010-1, Safety Requirements for Electronic Measuring Apparatus, and has been supplied in a safe condition. Make sure that you follow the recommendations in this section to ensure safe operation of your instrument and to maintain the product in a safe condition.

Laser Classification: This product is classified FDA Laser Class I (IEC Laser Class 1) laser.

- WARNING** **THIS EQUIPMENT MUST BE USED AS SPECIFIED OR THE PROTECTION PROVIDED BY THE EQUIPMENT MAY BE COMPROMISED. YOU MUST USE THIS PRODUCT IN A NORMAL MODE AND SHOULD NOT DEVIATE FROM THE WRITTEN INSTRUCTIONS PROVIDED.**
- WARNING** **THERE ARE NO OPERATOR SERVICEABLE PARTS INSIDE. REFER SERVICING TO QUALIFIED PERSONNEL. TO PREVENT ELECTRICAL SHOCK, DO NOT OPEN OR REMOVE COVERS.**
- WARNING** **TO PREVENT ELECTRICAL SHOCK, TURN OFF THE POWER TO THE INSTRUMENT BEFORE CLEANING. USE A DRY OR SLIGHTLY DAMPENED (WITH WATER) CLOTH TO CLEAN THE EXTERNAL PARTS. DO NOT ATTEMPT TO CLEAN ANYTHING INSIDE THE MACHINE.**
- WARNING** **THIS IS A SAFETY CLASS 1 PRODUCT . PLUG THE MAIN POWER CORD INTO A SOCKET OUTLET PROVIDED WITH A PROTECTIVE EARTH CONTACT. ALWAYS USE A THREE-PRONG AC POWER CORD WITH THIS EQUIPMENT. FAILURE TO ENSURE ADEQUATE GROUNDING MAY CAUSE INSTRUMENT DAMAGE.**

Unpacking & Inspection

The WA-1100 and WA-1600 are packed in a carton designed to give maximum protection during shipment. If the outside of the shipping carton is damaged, notify your shipping department immediately. Your shipping department may want to notify the carrier.

If the external shipping carton is not damaged, carefully remove and identify all of the components listed below. Contact EXFO or your local representative if any of the components are missing. We recommend you save the shipping carton for future storage or transportation.

WA-1100 and WA-1600 systems include the following components:

- Wavemeter unit
- Power cord
- Operating manual

Setup

Setting up the WA-1100/1600 is a very simple operation as described in the procedure below.

1. Place the instrument on a firm horizontal surface.
2. Attach the AC line cord. The instrument uses a universal power supply that works with any line voltage 90-260 VAC, 50/60 Hz.
3. Turn on the Power Switch. The system's self-test takes approximately 30 seconds. For WA-1600 models, the display indicates Laser Warm-up and the elapsed time, in minutes, since the instrument was turned on. This message is displayed until the reference laser inside the WA-1600 is stabilized. Typical laser warm-up time is approximately 6 minutes (WA-1600 only).
4. Ensure all fiber optic connectors are clean and dry (see below). Then connect your fiber optic cable to the fiber optic connector on the instrument front panel. Make sure the fiber end does not rub against any surface and do not overtighten.

CAUTION Use care in handling fiber optic connectors. Always clean the fiber end prior to insertion into the connector for optimum performance and to avoid power measurement errors.

Fiber End Cleaning

To make good optical measurements, it is extremely important to clean the fiber optic connector before each connection. Dirt on the connector can degrade the reliability of the measurement and cause permanent damage to the connector resulting in an expensive repair.

Modern fiber optic connectors rely on a glass-to-glass contact to reduce Fresnel reflections at the connector interface. A dirty or damaged connector on the cable can damage the input connector on the front panel. Always use a good quality cable

connector. If there is any question of the surface quality on the tip of the cable connector, inspect it under a microscope for scratches or debris. Your instrument may use a Fiber Optic Connector or a Universal Connector. Follow the appropriate procedure below.

Some general recommendations:

- Never use a metal or other hard object for cleaning that would scrape the connector.
- Do not apply index matching gel or oils.
- Always keep connectors covered for protection when not in use.

Cleaning a Fiber Optic Connector

To clean the end of the connector on the fiber optic cable,

1. Gently wipe the tip with a lint-free swab or lens paper dipped in isopropyl alcohol.
2. Dry it by wiping gently with a clean dry lint-free lens paper.
3. As soon as the connector is dry, insert it in the panel or cover it for later use.

Cleaning a Universal Connector

NOTE Refer to the illustration below.

To clean the end of the Universal Connector,

1. Unscrew the fiber from the Instrument and put a protective cap on it.
2. Close the Universal protective fiber cap.
3. Gently push in the universal connector and rotate it counter-clockwise $\frac{1}{4}$ turn.
4. Pull out the fiber optic adapter.
5. Gently wipe the tip with a lint-free swab or lens paper dipped in isopropyl alcohol.
6. Dry it by wiping gently with a clean dry lint-free lens paper.
7. As soon as the connector is dry, insert it in the WA-1100 or WA-1600 front panel or cover it for later use.

NOTE The fiber optic adapter is keyed. Insert the adapter in the same position that you removed it.

8. Rotate the universal connector $\frac{1}{4}$ turn to lock it in.

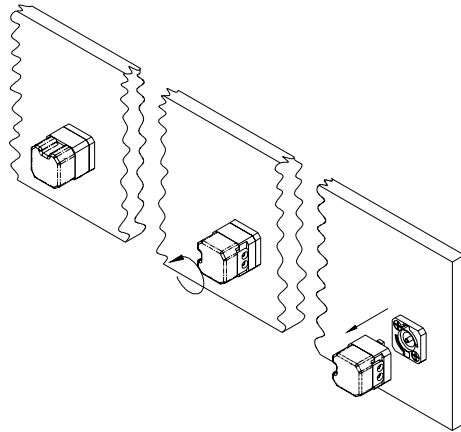

Fan Filter Cleaning

The fan on the rear panel of the WA-1100/1600 provides important ventilation to components inside the chassis. A filter covers the fan opening to keep out dust. This filter should be cleaned periodically, especially if it becomes noticeably dirty.

To clean the dust filter,

1. Pry off the plastic grill covering the filter with a small screwdriver.
2. Use a small brush, plus soap and water if necessary to clean the filter.
3. When the filter is dry, reposition it and snap the grill back in place.

2. Front Panel Communications

This section provides information on the front panel controls, describes the display and setup screens and provides instructions on changing screen displays and parameter values.

Front Panel Controls

The front panel is shown in Figure 2.1. The controls are described in Table 2-1.

The display consists of an 8½ digit numerical readout and buttons for selecting parameters that affect how the data is collected and how the information is displayed. There are several different screens, each with different information as shown and described later in this section.

Figure 2-1. Front Panel

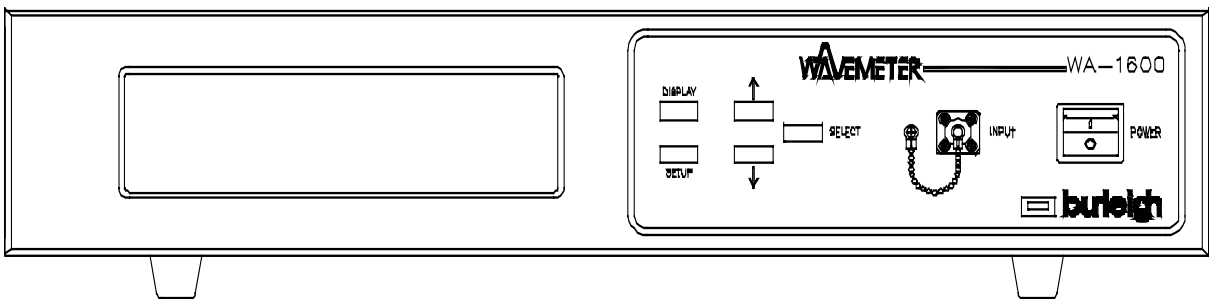

Table 2-1. Front Panel Controls

Control	Description
power	Switch turns the Instrument on and off.
LED	Indicator shows the power status. When lit, the unit is turned on, when not lit, the unit is off.
display	Button cycles through the display screens: Main, Wavelength and Power. Display screens contain parameters you can review and select as well as calculated or measured data for review only. Refer to 'Display Information' later in this section for additional information.
setup	Button cycles through the setup screens: Measurement, Communications, System, Status and Diagnostics. Setup screens contain a list of parameters for review and change. Refer to 'Setup Information' later in this section for additional information.
select	Button "highlights" or selects parameters on the displayed screen.
↑ and ↓	Buttons change the value of the selected parameter.

Using the Front Panel Controls

Use the four display area controls to review information and make changes to the available parameters. The headings below provide information on how to perform various procedures using these front panel controls.

Change Screens

To change which display screen is shown, press display. The Instrument cycles between the display screens.

To change which setup screen is shown, press setup. The instrument cycles between the setup screens.

Change Parameter Values

Each display and setup screen contains parameters whose values you can change. (Display screens also contain calculated or measured data.) Some parameters are located below the line on the bottom of the display screens and other parameters are located above the line, such as the wavelength and power units. Refer to Figures 2-2 through 2-4 for graphic illustrations of the parameters on each display screen.

To change a parameter value or status, press select to "highlight" the parameter field, then press \uparrow or \downarrow . The parameter's value or status changes.

NOTE If the message "Remote Lockout" is displayed on the screen when you attempt to change a parameter value, remote communications is enabled (On). When enabled, you can use the front panel controls to review all parameter values, but you cannot change any parameters except the status of the remote feature to off.

Save Parameter Values

You may want to save parameter values that are appropriate for your application, so that each time you power up the instrument, this information is automatically selected. Or, if you have several instruments, you may want to set them all up the same way.

The only parameter for which you cannot save the current value is the gain. On power up, the gain is set to the default status of "Auto".

To save parameter values, display the Configuration screen, press select to "highlight" the Save All field, then press either \uparrow or \downarrow . The current parameter values are saved.

Restore Saved Parameter Values

You may want to restore saved parameter values, for example, if you changed the value for a parameter, or several parameters, to observe their effect, but then decide you want to use the initial values.

To restore saved values, display the Setup Measurements screen, press select to "highlight" the Restore All field. The saved values are restored.

Display Screens

The display screens provide measurement information as summarized below. Figures 2-2 through 2-5 show each display screen and Table 2-2 describes each item on these screens.

Main. Initially displays a start-up screen for approximately 30 seconds after you first power on the unit. After a self-test and reference laser warm-up (WA-1600 only), the screen is replaced with summary information on the current wavelength and power and pertinent parameter values. For WA-1600s only, if the warm-up time is greater than 59 minutes, an exception occurs, which causes the wavelength to not be displayed, yet all system functions are active. Typical warm-up time at room temperature (20°C) is less than seven minutes

Wavelength. Displays wavelength information and two methods of calculating delta (Δ) for a comparative analysis. This screen shows the following numeric values: Current wavelength, Start, Δ (Current – Start), Maximum, Minimum, Δ (Maximum – Minimum) as well as the elapsed time and pertinent parameter values.

Power. Displays power information and two methods of calculating delta (Δ) for a comparative analysis. This screen shows the following numeric values: Current power, Start, Δ (Current – Start), Maximum, Minimum, Δ (Maximum – Minimum) as well as the elapsed time and pertinent parameter values.

Figure 2-2. Main Screen

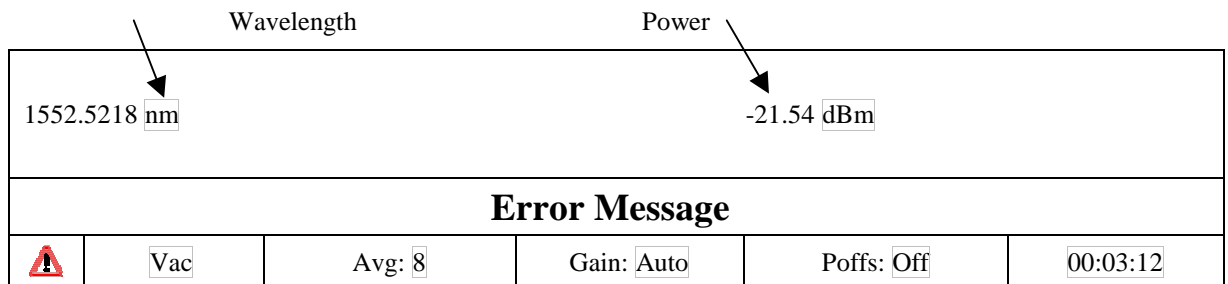

Figure 2-3. Wavelength Screen

1552.5218 nm		Start: 1552.5212	Δ: 0.0006
Max: 1552.5200		Min: 1552.5235	Δ: 0.0035
Error Message			
	Vac	Avg: 8	Gain: Auto
			Reset
00:03:12			

Figure 2-4. Power Screen



-11.54 dBm		Start: -11.52	Δ: -0.02
Max: -11.60		Min: -11.50	Δ: -0.01
Error Message			
	Vac	Avg: 8	Gain: Auto
			Reset
00:03:12			

Table 2-2. Display Screen Information

Parameter	Description
Avg	Displays the number of previous measurements used to calculate the running average. Calculation of the average wavelength and power uses the same average value. On the Main and Wavelength screens, you can toggle the average between Off and the numeric value set using the Measurement setup screen. Off. Indicates averaging is not used. Numeric value (2, 4, 8, 16, 32, 64, or 128). Change the numeric value on the Measurement setup screen.
Gain	Displays the gain option used when measuring the wavelength and power. Change the gain status on the Main display and Measurement setup screens. Auto. Permits the system to adjust the gain automatically. Fixed. Uses a fixed value, which is the current gain value at the time you pressed ↑ or ↓ on the front panel to change the gain from "Auto" to "Fixed".
Medium	Identifies the medium in which the measurement occurs as standard air (20°C, 760 mm Hg and 0% relative humidity) or vacuum. You can change the medium to vacuum on the Main and Wavelength screens.

Poffs	<p>Displays the power offset value applied to subsequent power measurements. The power offset values enable you to obtain accurate power readings when you place an attenuator external to the instrument. If you enter a power offset value equal to the external attenuator, the instrument automatically displays the correct power. This is useful if the signal input power exceeds the maximum allowed input of 10 mW (10 dBm).</p> <p>Off indicates a power offset is not used.</p> <p>Numeric value (1, 2, ..., 20 in dB units). You cannot change the type of units. Change the numeric value on the Measurement setup screen.</p>
Power	The current laser power displayed in the selected units. You can change the type of units on the Main or Power display screen. The options are dBm, mW or μ W.
Reset	Restarts calculations of Current – Start and Max - Min. When actuated, it zeros elapsed time, then displays the start and current values.
Error Message	Indicates an error message, if any. Refer to Appendix C for messages and corrective action.
Vacuum	You can change the medium to standard air on the Main and Wavelength screens.
Wavelength	<p>The current wavelength displayed in the selected units. You can change the units on the Main or Wavelength display screen. The units are nm, cm-1 and GHz.</p> <p>If an error has occurred, this area displays a status message.</p> <p>Refer to Appendix C for messages and corrective action.</p>
	Presence indicates that an exception has occurred. Check the status screen or read the status byte (see *STB Command on page 3-7). Refer to Appendix C for messages and corrective action.

Setup Screens

The setup screens provide information that affects the display of measured values and calculation of values. Each screen is summarized below and described in more detail in the tables that follow.

Configuration. Contains parameters that affect how the instrument makes specific calculations and how it determines the information on the instrument display, for example, save and recall the parameter selections, change the brightness of the instrument display, and reset the null value for power measurement. Refer to Table 2-3 for details.

Communications. Use to change remote communication parameters. Refer to Table 2-4 for details.

Information. Displays the instrument's serial number and software version information, reference laser information, pressure, and internal temperature for review. The WA-1600 reference laser information includes the peak power, percent of peak power and the minutes to warm up, and the WA-1100 displays just the peak power.

Status Displays the status codes that indicate the latest exceptions that have occurred. See Appendix C for descriptions and corrective action.

Table 2-3. Configuration Information

Parameter	Description/Options
Resolution	Identifies the wavelength resolution value. Auto. Permits the instrument to set the resolution based on the calculated bandwidth of the laser. See the description of auto-resolution on page 4-6. .001, .01, 0.1, 1.0, 10.0. Selectable wavelength resolution values. Displayed values are rounded off to the selected number of decimal places. The .0001 resolution is not available for the WA-1100.
Average	Identifies the number of previous wavelength and power values to use to calculate the running average. The display is updated with each new measurement. Off. Indicates values are not averaged. 2, 4, 8, ..., 128 (powers of 2). Selections for average values.
Power Offset	Displays the power offset (Poffs) value applied to subsequent power measurements. The power offset values enable you to obtain accurate power readings when you place an attenuator external to the instrument. If you enter a power offset value equal to the amount of external attenuation, the instrument automatically displays the correct power. This is useful if the signal input power exceeds the maximum allowed input of 10 mW (10 dBm). Change the offset value on the Main and Measurement setup screens. Off indicates a power offset is not used. 1, 2, ...20 in dBm units. You cannot change the units for the offset.
Gain	Displays the gain option used when measuring the wavelength. You can change the gain option on any display screen. This setting is not saved by the Save All command and defaults to Auto-On at power up. Auto. Permits the system to adjust the gain of the fringe amplifier automatically. Fixed. Uses a fixed gain of the fringe amplifier, which is the current gain value at the time you pressed \uparrow or \downarrow on the front panel to change the gain from Auto to Fixed. Once fixed, the working range is approximately -3 dBm to $+6$ dBm.
Power Null	Resets the null value used in the power calculation. Use only when no light is entering the instrument and the fiber connector cap is on.
Brightness	Changes the brightness of the display. High. Maximum intensity. Low. 62.5% of the maximum intensity.
Save All	Allows you to save the current parameter values.
Restore All	Allows you to restore the saved parameter values.

Table 2-4. Communications Information

Parameter	Description/Options
Remote (Lockout)	When enabled (On) you can use the front panel controls to review parameter values, but can only change (disable) the "Remote" parameter. Attempting to change other parameters when this feature is enabled will display the message "Remote Lockout". Off. Permits changing all front panel controls.
RS-232	Enables (On) and disables (Off) communications via the RS-232 port.
Baud	Identifies the baud rate for the RS-232 communications. The selections are: 1200, 2400, 4800, 9600 and 19200 baud.
Handshaking	Identifies the type of handshaking used for the RS-232 communications. The selections are Hardware, Xon/Xoff (software) or None.
GPIB	Enables (On) and disables (Off) communications via the GPIB port.
Address	Identifies the address used for GPIB output. The selections are 0, 1, 2, ..., 31.

3. Remote Communications

This section discusses the use of remote communications to review and control the instrument.

Overview

You can control the instrument remotely using either an RS-232 or a GPIB interface using the SCPI communications scheme. Connections for both interfaces are provided on the back of the instrument as shown later in this section.

You must use the instrument front panel controls to enable remote communications for the specific type of interface. Refer to Table 2-4 in Section 2 of this manual for information.

GPIB System Controller Settings

This section describes how to set up your GPIB system controller for proper message termination and bus timing to communicate with the WA-1100 or WA-1600. Other settings may also work, but these are the settings that we've found to work the best.

Set EOI at End of Write = Yes

This causes the system controller to assert the EOI signal during the last byte of a message written to the instrument.

Set EOI With EOS on Write = No

The system controller should not assert the EOI signal when it writes an EOS character. The system controller should instead assert the EOI signal when sending the last byte of the message (which will be an EOS character anyway).

EOS Byte = 10

The instrument uses a linefeed character (10, 0x0a, or \n) to identify the end of a message.

8-Bit EOS Compare = Yes

This causes the system controller to examine all eight bits of a received character to determine if it is an EOS character.

Terminate Read on EOS = Yes

The instrument terminates all of its messages with an EOS character. It never uses the EOS character within a message. Therefore, when the system controller receives an EOS character from the instrument, it can assume that it has received the last character of the message.

GPIO Bus Timing = 2000ns or 2µs

This sets the minimum time that the system controller will assert the DAV signal after driving a byte onto the bus.

SCPI Communications Scheme

This topic provides information on the communication scheme that follows the Standard Commands for Programmable Instruments (SCPI) Syntax and Style Guidelines.

Table 3-3 provides a summary of commands by subsystem and the information after the table describes each command in detail.

Note: [...] indicates an optional argument. {...|...|...} indicates a choice from a set of arguments.

Table 3-3. SCPI Command Summary

Group & Command	Description
Common Commands	These commands are defined by IEEE 488.2 and control some functions that are common to all IEEE 488.2 instruments.
*CLS	Clears all event registers and the error queue.
*ESE?	Queries the bits in the standard event status enable register.
*ESE <integer>	Sets the bits in the standard event status enable register.
*ESR?	Queries value standard event status register.
*IDN?	Queries instrument model number, serial number and firmware version.
*OPC?	Queries the operation complete bit of the standard-event status register.
*OPC	Sets operation complete bit of the standard event status register.
*RCL	Restores instrument settings.
*RST	Resets instrument to default settings.
*SAV	Saves instrument settings.
*STB?	Queries the value of status byte.

Measurement Instructions	These commands configure and obtain measurements from the instrument.
:CONFigure?	Queries the measurement subsystem for measurement type.
:CONFigure{:POWer :ENVironment :WAVelength :WNUM :FREQuency}	Configures the MEASurement subsystem for power, environment, wavelength, wavenumber or frequency.
:FETCh{:POWer :ENVironment :FREQuency :WAVelength :WNUMBER}?	Queries power, environment, wavelength, wavenumber and frequency that have already been captured during the last scan.
:MEASure{:POWer :ENVironment :FREQuency :WAVelength :WNUMBER }?	Queries power, environment, wavelength, wavenumber and frequency that will be captured during the next scan. Measure is the equivalent of ABORT; INITiate; FETCh.
:READ{:POWer :ENVironment :FREQuency :WAVelength :WNUMBER}?	Queries power, environment, wavelength, wavenumber and frequency that will be captured during the next scan. READ is the equivalent of ABORT; INITiate; FETCh. READ is interpreted to mean, "Initiate a new reading and return the value when the reading is complete".
CALCulate Subsystem	These commands obtain calculated values from the instrument. In general, calculated values are values derived from actual measurements.
:CALCulate:DATA? {POWer FREQuency WAVelength WNUMBER }	Used to set the type of data retrieved from the calculate subsystem.
:CALCulate:DELTA[:STATe]?	Queries if DELTA is to be calculated.
:CALCulate:DELTA[:STATe] { ON OFF }	Selects DELTA as the quantity to be calculated.
:CALCulate:DELTA:METHod?	Queries the method used for DELTA calculation (either Current-Start or Max-Min).
:CALCulate:DELTA:METHod { START MAXMin }	Selects the method used for DELTA calculation (either Current-Start or Max-Min).
:CALCulate:MAXimum[:STATe]?	Queries if MAXimum is to be calculated.
:CALCulate:MAXimum[:STATe] { ON OFF }	Selects MAXimum as the quantity to be calculated. This is the maximum value since the power-on or the last reset.
:CALCulate:MINimum[:STATe]?	Queries if MINimum is to be calculated.
:CALCulate:MINimum[:STATe] {ON OFF}	Selects MINimum as the quantity to be calculated. This is the minimum value since power-on or the last reset.
:CALCulate:RESet	Resets the CALCulate subsystem. This command resets the Elapsed Time counter, sets the Min & Max values to the Current value, and sets the Start value to the Current value.
:CALCulate:START[:STATe]?	Queries if START is to be calculated.

:CALCulate:START[:STATe] {ON OFF}	Selects START as the quantity to be calculated. This is the first good reading after power-on or last reset.
:CALCulate:TIME[:ELAPsed]?	Returns the time since last power on or reset.
DISPlay Subsystem	These commands change the state of the instrument's front panel.
:DISPlay:DIALog?	Queries the current display screen on the front of the instrument.
:DISPlay:DIALog {MAIN WAVelength POWer}	Selects the current display screen on the front of the instrument.
:DISPlay:RESolution?	Queries the display resolution.
:DISPlay:RESolution {AUTO .0001 .001 .01 .1 1.0 10.0}	Selects the display resolution. The .0001 resolution is not available on the model WA-1100.
:DISPlay:UNITs:POWer?	Queries the power units used for display.
:DISPlay:UNITs:POWer {DBM MICRowatts MILLiwatts}	Selects the power units used for display.
:DISPlay:UNITs:WAVelength?	Queries the wavelength units used for display.
:DISPlay:UNITs:WAVelength {NM GHZ WNUMber }	Selects the wavelength units used for display.
SENSe Subsystem	These commands are used to control factors which effect the way in which the measurements are taken.
:SENSe:AVERage?	Queries the amount of averaging that is used in the instrument.
:SENSe:AVERage {OFF 2 4 8 ... 128}	Sets the amount of averaging that is used in the instrument.
:SENSe:MEDium?	Queries the type of medium in which the measurements are being made.
:SENSe:MEDium {AIR VACuum}	Selects the type of medium in which the measurements are being made.
:SENSe:POWeroffset?	Queries the power offset for the measurements in dBm.
:SENSe:POWeroffset {OFF 1 ... 20}	Selects the power offset for the measurements in dBm.
:SENSe:GAIN?	Queries the gain of the instrument's fringe amplifier.

SENSE:GAIN { AUTO FIXed }	Sets the gain of the instrument's fringe amplifier.
:SENSE:REFERENCE[:PARAMeters]?	Returns information on the reference laser such as power (% of peak, and minutes to warm-up for WA-1600).
STATus Subsystem	These commands are used to retrieve SCPI or instrument status.
:STATus:QUESTIONable:CONDition?	This command queries the SCPI Questionable register, which contains bits that indicate that one or more measurement types are of questionable accuracy.
:STATus:QUESTIONable:ENABLE?	This command queries the Questionable Enable register.
:STATus:QUESTIONable:ENABLE <integer>	Used to set and clear bits in the SCPI Questionable Enable register.
:STATus:QUESTIONable:HARDware:CONDition?	This command queries the hardware to provide information on the status of some of the hardware components, which may contribute to invalid or erred measurements.
SYSTEM Subsystem	These commands control system-wide parameters.
:SYSTEM:ERROR?	Reads error strings from the Error Queue. If the Error Queue has any entries, the Error Queue bit is set in the Status Byte.
:SYSTEM:HELP:HEADers?	This query returns a list of all commands/queries supported by the instrument.
:SYSTEM:REMOte?	This query checks if the front panel is enabled or not. If ON, the front panel is locked out
:SYSTEM:REMOte { ON OFF }	This command controls whether the front panel is enabled or not. If in Remote mode, the front panel is locked out
:SYSTEM:VERSion?	Returns the year and revision of the SCPI standard that the instrument follows.
TRIGger Subsystem	These commands control the triggering of the instrument. Since the instrument is fundamentally not a triggered instrument, these commands have little effect on the instrument's operation.
:TRIGger:ABORt	Aborts a current measurement.
:TRIGger:INITiate[:IMMediate]	Initiates a new reading.
UNIT Subsystem	This command effects the power units used by the SCPI interface.
:UNIT:POWer?	Queries power units (dBm or watts).
:UNIT:POWer { DBM W }	Selects power units to be dBm or watts. This command does not affect the front panel display in any way.

SCPI Command Detail

This section provides detailed information for all instrument SCPI programming commands. The commands are organized by subsystem.

Common Commands

*CLS

Description	The *CLS (clear status) command clears the event status register and the error queue.
-------------	---

*ESE?

Description	Queries the bits in the event status enable register.
Query Response	Returns an integer which is the sum of all the bit values for those bits that are set. (See Event Status Register Enable table below.)

*ESE <integer > mask from 0 to 255

Description	The *ESE (event status enable) command sets the bits in the event status enable register and enables the corresponding events in the event status register. For each bit that is set (equal to 1), it is enabled in the event status register (ESR). <integer> is an integer which is the sum of all of the bit values for those bits that are set.
-------------	---

Event Status Enable Register

Bit	Bit Value	Enables
7	128	Power On (PON)
6	64	Not Used
5	32	Command Error (CME)
4	16	Execution Error (EXE)
3	8	Device Dependent Error (DDE)
2	4	Query Error (QYE)
1	2	Not Used
0	1	Operation Complete (OPC)

***ESR?**

Description	The *ESR (event status register) query returns a value which encodes the bits in the event status register. If any bits are set in the ESR, then the ESR summary bit will be set in the STB.
Query Response	Returns an integer which is the sum of all the bit values for those bits that are set. (See Event Status Register table below.)

Event Status Register

Bit	Bit Value	Condition
7	128	Power On (PON)
6	64	Not Used
5	32	Command Error (CME)
4	16	Execution Error (EXE)
3	8	Device Dependent Error (DDE)
2	4	Query Error (QYE)
1	2	Not Used
0	1	Operation Complete (OPC)

***IDN?**

Description	The *IDN (identification number) query returns a string value which contains the instrument type, serial number, and firmware version. The third value is the instrument serial number. The last value is the software version and will reflect the actual version number.
Query Response	BURLEIGH WAVEMETER, WA-1100, 1001, 1.0

***OPC?**

Description	The operation complete query (*OPC?) returns a one (1) when all pending device operations are complete.
Query Response	{0 1}

***OPC**

Description	The *OPC (operation complete) command sets the operation complete bit in the event status register when all pending operations are complete.
-------------	--

***RCL**

Description	The *RCL (recall) command restores instrument settings. It is the same as using the Restore All function through the display.
-------------	---

***RST**

Description	The *RST (reset) command returns the instrument's settings to a known state.
-------------	--

Commands affected by *RST

Command	Setting after an *RST command
:CALCulate:DELTA[STATE]	OFF
:CALCulate:DELTA:METHo d	STARt
:CALCulate:MAXimum[:STA Te]	OFF
:CALCulate:MINimum	OFF
:CALCulate:STARt[:STATE]	OFF
:DISPlay:DIALog	MAIN
:DISPlay:RESolution	AUTO
:DISPlay:UNITs:POWer	DBM
:DISPlay:UNITs:WAVelength	WAVelength
:SENSe:AVERage	OFF
:SENSe:MEDIum	VACuum
:SENSe:POWeroffset	OFF
SENSe:GAIN	AUTO
:SYSTem:REMote	OFF
:UNIT:POWer	DBM

***SAV**

Description	The *SAV command saves instrument settings. It is the same as using the Save All function through the display.
-------------	--

***STB?**

Description	The *STB (status byte) query returns the current value of the instrument's status byte.
Query Response	Returns an integer which is the sum of all the bit values for those bits that are set. (See the instrument Status Byte table.)

instrument Status Byte

Bit	Bit Value	Condition
5	32	a bit is set in the questionable register (see STATus subsystem)
3	8	errors are in the error queue (see SYSTem subsystem)
2	4	a bit is set in the event status register

Measurement Instructions

Use the measurement instructions to return a reading to the computer. The four basic measurement instructions are CONFigure, FETCh, READ, and MEASure. Functions for these instructions are POWer, ENVironment, WAVelength, WNUMber, and FREQuency.

A :FETCh will return a reading based on the last complete scan. Using :FETCh, it is possible to get new measurements at the instrument's scan rate of up to 10 per second on a WA-1100 and up to 1 per second on a WA-1600. However, if :FETCh queries are made faster than the instrument's scan rate, it is possible to get the same reading twice. Old readings are indicated by a bit in the questionable status register.

:MEASure and :READ get a new reading after the next complete scan. :MEASure and :READ guarantee that each reading returned is a new one. However, because :MEASure and :READ wait until after the next complete scan before returning a reading, measurement rates will be about half the instrument's scan rate. If you want to get multiple measurement types from a single scan (i.e. WAVelength, POWer, etc.), you should use :READ followed by one or more :FETCh queries.

:MEASure and :READ are actually macros that execute multiple SCPI commands. :READ is equivalent to:

```
:ABORt
:INITiate
:FETCh[:<function>]?
```

and :MEASure is equivalent to:

```
:ABORt
:CONFigure <function>
:READ?
```

For the instrument, :MEASure and :READ perform essentially the same function.

:CONFigure?

Description	Queries the current configuration of the measurement subsystem.
Query Response	{POWER ENVIRONMENT WAVELENGTH WNUMBER FREQUENCY}
Example	:CONF?

:CONFigure{:POWER | :ENVIRONMENT | :WAVELENGTH | :WNUMBER | :FREQUENCY}

Description	Configures the measurement subsystem for subsequent :FETCh?, :MEASure?, or :READ? queries.
Examples	:CONF:WNUM :CONF:POW

{:MEASure | :READ | :FETCh}{:POWER | :ENVIRONMENT | :WAVELENGTH | :WNUMBER | :FREQUENCY}?

Description	Queries a reading of the given type from the measurement subsystem.
Query Response	(see below)
Examples	(see below)

Measurement Instruction Functions

:POWER?

Description	Returns a power reading in either Watts or dBm as specified by the :UNIT:POWER function.
Query Response	A numerical value in scientific notation. (ex. -1.267E+001)
Examples	:READ:POW? :FETC:POW?

:ENVIRONMENT?

Description	Returns the instrument's internal temperature in °C and pressure in mmHG.
Query Response	Two numerical values with units separated by a comma. (ex. 28.5 C, 740 MMHG)
Examples	:MEAS:ENV? :FETC:ENV?

:WAVelength?

Description	Returns an input laser reading in units of nm.
Query Response	A numerical value in scientific notation (ex. 1.5461108E+003). The number of significant digits will be determined by the current resolution setting. Resolution is set through the front panel or by using the :DISPlay:RESolution command.
Examples	:FETC:WAV? :READ:WAV?

:WNUMber?

Description	Returns an input laser reading in units of cm^{-1} .
Query Response	A numerical value in scientific notation (ex.6.4646020E+003). The number of significant digits will be determined by current resolution setting. Resolution is set through the front panel or by using the :DISPlay:RESolution command.
Examples	:FETC:WNUM? :MEAS:WNUM?

:FREQuency?

Description	Returns an input laser reading in units of GHz.
Query Response	A numerical value in scientific notation (ex. 1.9367357E+005). The number of significant digits will be determined by the current resolution setting. Resolution is set through the front panel or by using the :DISPlay:RESolution command.
Examples	:FETC:FREQ? :MEAS:FREQ?

CALCulate Subsystem

Use the CALCulate subsystem to read and control the instrument's calculated values. The instrument continuously updates minimum and maximum readings as well as deriving deltas such as maximum-minimum and current-start.

To retrieve CALCulate subsystem data, first choose a calculate data type and then perform a calculate query. For example, to read maximum-minimum power, issue the following commands:

- :CALC:DELT:STAT ON (Set up to read a delta value.)
- :CALC:DELT:METH MAXM (Set up to read maximum-minimum.)
- :CALC:DATA? POW (Read the maximum-minimum power.)

The :DELTA, :MAXimum, and :MINimum functions are turned on and off with their respective commands. When one of them is turned on, the others are automatically turned off.

CALCulate Subsystem Functions

:DATA? {POWER | FREQUENCY | WAVELENGTH | WNUMBER}

Description	Gets a calculated value of a pre-selected data type. In order for this function to return a result, you must first set up the CALCulate subsystem using the :DELTA, :MAXimum, :MINimum, or :START functions.
Query Response	A numerical value in scientific notation (ex. -1.62E+000). The number of significant digits for a FREQUENCY, WAVELENGTH, or WNUMBER reading will be determined by the current resolution setting. Resolution is set through the front panel or by using the :DISPlay:RESolution command.
Examples	:CALC:DATA? POW :CALC:DATA? WAV

:DELTA[:STATE]?

Description	Queries the state of the :DELTA function.
Query Response	{0 1} Where 0 indicates OFF and 1 indicates ON.
Examples	:CALC:DELT:STAT? :CALC:DELT?

:DELTA[:STATE] {ON | OFF}

Description	Sets the state of the :DELTA function to either ON or OFF.
*RST value	OFF
Examples	:CALC:DELT OFF :CALC:DELT:STAT ON

:DELTA:METHod?

Description	Queries the state of the :METHod function.
Query Response	{START MAXMIN}
Examples	:CALC:DELT:METH?

:DELTA:METHOD {START | MAXMin}

Description	Sets the state of the :METHOD function to either START (to get start - current values) or MAXMin (to get maximum - minimum values).
*RST value	START
Examples	:CALC:DELTA:METH START :CALC:DELTA:METH MAXM

:MAXimum[:STATe]?

Description	Queries the state of the :MAXimum function.
Query Response	{0 1} Where 0 indicates OFF and 1 indicates ON.
Examples	:CALC:MAX? :CALC:MAX:STAT?

:MAXimum[:STATe] {ON | OFF}

Description	Sets the state of the :MAXimum function to either ON or OFF.
*RST value	OFF
Examples	:CALC:MAX ON :CALC:MAX:STAT OFF

:MINimum[:STATe]?

Description	Queries the state of the :MINimum function.
Query Response	{0 1} Where 0 indicates OFF and 1 indicates ON.
Examples	:CALC:MIN? :CALC:MIN:STAT?

:MINimum[:STATe] {ON | OFF}

Description	Sets the state of the :MINimum function to either ON or OFF.
*RST value	OFF
Examples	:CALC:MIN ON :CALC:MIN:STAT OFF

:RESet

Description	Resets the minimum, maximum, and start values to the current reading. Resets the deltas to zero, and sets the elapsed time to 00:00:00. This affects the CALCulate subsystem as well as the instrument's front panel display. It is the same as using the Reset function through the display.
Examples	:CALC:RES

:START[:STATe]?

Description	Queries the state of the :START function.
Query Response	{0 1} Where 0 indicates OFF and 1 indicates ON.
Examples	:CALC:STAR? :CALC:STAR:STAT?

:START[:STATe] {ON | OFF}

Description	Sets the state of the :START function to either ON or OFF.
*RST value	OFF
Examples	:CALC:STAR ON :CALC:STAR:STAT OFF

:TIME[:ELAPsed]?

Description	Queries the elapsed time since the instrument was turned on or was reset.
Query Response	A time in HH:MM:SS format.
Examples	:CALC:TIM? :CALC:TIM:ELAP?

DISPlay Subsystem

The DISPlay subsystem is used to manipulate the instrument's front panel through the serial or GPIB SCPI interface. These commands do not affect the readings from the SCPI interface except for the :RESolution function.

DISPlay Subsystem Functions**:DIALog?**

Description	Queries what display dialog is currently on the instrument's front panel display. The return value for this function is invalid if the instrument is on a setup dialog.
Query Response	{ MAIN WAVELENGTH POWER }
Examples	:DISP:DIAL?

:DIALog {MAIN | WAVelength | POWer}

Description	Sets the dialog that is on the instrument's front panel display.
*RST value	MAIN
Examples	:DISP:DIAL MAIN :DISP:DIAL POW

:RESolution?

Description	Queries the current resolution of the instrument.
Query Response	{ AUTO 0.0001 0.001 0.01 0.1 1.0 10.0 100.0 }
Examples	:DISP:RES?

:RESolution {AUTO | 0.0001 | 0.001 | 0.01 | 0.1 | 1.0 | 10.0 | 100.0}

Description	Sets the resolution for wavelength, frequency, and wavenumber readings. It is the same as using the Resolution function through the display. The 0.0001 setting is valid only for the WA-1600 instrument.
*RST value	AUTO
Examples	:DISP:RES AUTO :DISP:RES 0.0001

:UNITs:POWer?

Description	Queries the units being used for power values on the front panel display.
Query Response	{ DBM MICROWATTS MILLIWATTS }
Examples	:DISP:UNIT:POW?

:UNITs:POWer {DBM | MICRowatts | MILLiwatts}

Description	Sets the units being used for power values on the front panel display. It is the same as changing the power units through the display. If the units are set to MICRowatts or MILLiwatts, the display may switch to MILLiwatts or MICRowatts due to the display's power auto ranging feature.
*RST value	DBM
Examples	:DISP:UNIT:POW MICR :DISP:UNIT:POW DBM

:UNITs:WAVelength?

Description	Queries the units being used for wavelength values on the front panel display.
Query Response	{NM GHZ WNUMBER}
Examples	:DISP:UNIT:WAV?

:UNITs:WAVelength {NM | GHZ | WNUMber}

Description	Sets the units being used for wavelength values on the front panel display. It is the same as changing the wavelength units through the display.
*RST value	NM
Examples	:DISP:UNIT:WAV WNUM :DISP:UNIT:WAV NM

SENSE Subsystem

The SENSE subsystem allows changes in how the instrument makes measurements and it provides information on the reference laser.

SENSe Subsystem Functions

:AVERage?

Description	Queries the number of readings being averaged for wavelength and power values.
Query Response	{OFF 2 4 8 16 32 64 128}
Examples	:SENS:AVER?

:AVERage {OFF | 2 | 4 | 8 | 16 | 32 | 64 | 128}

Description	Sets the number of readings being averaged for wavelength and power values. It is the same as using the Average function through the display.
*RST value	OFF
Examples	:SENS:AVER OFF :SENS:AVER 8

:MEDium?

Description	Queries the medium used for wavelength calculations.
Query Response	{AIR VACUUM}
Examples	:SENS:MED?

:MEDium {AIR | VACuum}

Description	Sets the medium used for wavelength calculations. It is the same as using the Medium function through the display.
*RST value	VAC
Examples	:SENS:MED AIR :SENS:MED VAC

:POWERoffset?

Description	Queries the power offset being added to power values. It is the same as using the Poffs function through the display. The power offsets are in units of dBm.
Query Response	{OFF 1 2 3 ... 19 20}
Examples	:SENS:POW?

:POWERoffset {OFF | 1 | 2 | 3 | ... | 19 | 20}

Description	Sets the power offset to be added to power values. The power offsets are in units of dBm.
*RST value	OFF
Examples	:SENS:POW OFF :SENS:POW 3

:GAIN?

Description	Queries the gain state of the instrument's fringe amplifier.
Query Response	{AUTO FIXED}
Examples	:SENS:GAIN?

:GAIN {AUTO | FIXEd}

Description	Sets the gain state of the instrument's fringe amplifier. It is the same as using the Gain function through the display.
*RST value	AUTO
Examples	:SENS:GAIN AUTO :SENS:GAIN FIX

:REFerence[:PARAmeters]?

Description	Queries the reference laser status.
Query Response	For the WA-1600, power in μ W, % of peak power, and minutes to warm up are returned separated by commas. (ex. 267.0 UW, 76 %, 7) For the WA-1100, just the power in μ W is returned. (ex. 267.0 UW)
Examples	:SENS:REF? :SENS:REF:PAR?

STATus Subsystem

The STATus subsystem is used to retrieve status information from the instrument and to mask or screen what status is able to be retrieved.

Status registers give information about the instrument and the latest measurement. Status enable registers allow some status information to be ignored. Status information disabled though the status enable registers will not show up in the status registers.

STATus Subsystem Functions

:QUESTionable:CONDition?

Description	Queries the SCPI Questionable register which contains bits that indicate that one or more measurement types are of questionable accuracy. The bits in the register are described in the table below.
Query Response	An integer which is the sum of the bit values for all bits in the register that are set.
Examples	:STAT:QUES:COND?

Questionable Register

Bit	Bit Value	Description
0	1	The wavelength has already been read for the current scan.
1	2	(not used)
2	4	(not used)
3	8	The power value is outside the valid range of the instrument.
4	16	The temperature value is outside the valid range of the instrument.
5	32	The wavelength value is outside the valid range of the instrument.
6	64	(not used)
7	128	(not used)
8	256	(not used)
9	512	The pressure value is outside the valid range of the instrument.
10	1024	Indicates that at least one bit is set in the Questionable Hardware Condition register.

:QUESTionable:ENABle?

Description	Queries the SCPI Questionable Enable register.
Query Response	An integer which is the sum of the bit values for all bits in the register that are set.
Examples	:STAT:QUES:ENAB?

:QUESTionable:ENABle <integer>

Description	Used to set and clear bits in the SCPI Questionable Enable register. This register contains bits that are used to mask one or more conditions indicated in the Questionable register. Setting a bit causes that condition to be masked so that, even if the condition is true, its associated bit will not get set in the Questionable register. The Questionable Enable register has the same format as the Questionable register. (See table above)
Examples	:STAT:QUES:ENAB 1 :STAT:QUES:ENAB 1024

:QUESTionable:HARDware:CONDition?

Description	Queries the SCPI Questionable Hardware Condition register which contains bits that indicate that one or more hardware problems exist. These problems may contribute to invalid or erred measurements. The bits in the register are described in the table below.
Query Response	An integer which is the sum of the bit values for all bits in the register that are set.
Examples	:STAT:QUES:HARD:COND?

Questionable Hardware Condition Register

Bit	Bit Value	Description
0	1	Reference laser has not stabilized. (WA-1600 only)
1	2	Reference laser is over temperature. (WA-1600 only)
2	4	No reference laser fringes detected during scan.
3	8	Lost reference laser fringes during scan.
4	16	Analog to digital converter error.
5	32	Failed to read the EEPROM.
6	64	Failed to read or write to the SRAM.
7	128	The scan assembly has stopped moving.
8	256	The input laser fringe strength is too low.
9	512	Fringe counter error.

10	1024	Fringe counter overflow.
11	2048	Fringe counter invalid.
12	4096	The input laser fringe strength is too high.
13	8192	The reference laser % of peak power is out of range. (WA-1600 only)

SYSTem Subsystem

The SYSTem subsystem supplies information and status about the SCPI command parser and allows control over the instrument's front panel.

SYSTem Subsystem Functions

:ERRor?

Description	Reads error strings from the SCPI Error Queue. If the Error Queue has any entries, the Error Queue bit is set in the Status Byte. The instrument has a 30 entry, first-in, first-out queue. Repeatedly sending the query :SYST:ERR? returns the error numbers and descriptions in the order in which they occurred until the queue is empty. Any further queries return 0, "No error" until another error occurs. A table of possible errors is shown below.
Query Response	<integer>, <string> (ex. -104, "Data type error")
Examples	:SYST:ERR?

SCPI Errors

Error Number	Description
0	No error
-101	Invalid character
-102	Syntax error
-103	Invalid separator
-104	Data type error
-220	Parameter error
-221	Settings conflict
-222	Data out of range
-230	Data corrupt or stale

:HELP:HEADers?

Description	Reads a list of all commands and queries supported by the instrument. Each line of the response is terminated by a linefeed. The first line indicates the number of bytes of help data that follow. The remaining lines are strings of help data. All lines of data must be read before continuing normal operations.
Query Response	#<integer> <string> <string> <string> ... <string>
Examples	:SYST:HELP:HEAD?

:REMote?

Description	Queries the state of the remote lockout feature.
Query Response	{ON OFF}
Examples	:SYST:REM?

:REMote {ON | OFF}

Description	Sets the state of the remote lockout feature. When the state is ON, front panel input is locked out and the instrument can only be operated remotely using SCPI commands.
*RST value	OFF
Examples	:SYST:REM ON :SYST:REM OFF

:VERSion?

Description	Returns the version of the SCPI specification that the instrument's SCPI interface is based on. The first integer is the year and the second integer is the approved revision number for that year.
Query Response	<integer>.<integer>
Examples	:SYST:VERS?

TRIGger Subsystem.

The instrument is unlike most SCPI instruments in that it is continuously taking readings and when a reading starts is under the control of the scan engine and not the user. As a result, the user should not attempt to control the instrument through the Trigger subsystem. The commands below are listed only for the sake of completeness.

TRIGger Subsystem Functions

:ABORt

Description	Halts acquisition of the current reading and returns the instrument to an idle state.
Examples	:ABOR

:INITiate[:IMMEDIATE]

Description	Starts the acquisition of a new reading.
Examples	:INIT :INIT:IMM

UNIT Subsystem

For the instrument, there is a single query and command in the UNIT subsystem. They query and change the units that the SCPI interface uses for reporting power.

UNIT Subsystem Functions

:UNIT:POWer?

Description	Queries the state of the power units that will be used when the SCPI interface returns power values.
Query Response	{DBM W}
Examples	:UNIT:POW?

:UNIT:POWer {DBM | W}

Description	Sets the state of the power units that will be used when the SCPI interface returns power values. This setting does not affect the front panel display.
*RST value	DBM
Examples	:UNIT:POW DBM :UNIT:POW W

4. Theory of Operation & Calibration

This section reviews the theory behind wavelength measurement as it applies to the WA-1100 and WA-1600 instruments. It also discusses the factors that influence the accuracy of the measurement.

Operating Principles

A variety of techniques have been devised to determine the wavelength of lasers. Interferometric techniques have proven to be the most practical, precise and reliable for wavelength measurement instrumentation.

The WA-1100 and WA-1600 use a Michelson interferometer to generate sinusoidal interference fringes from the input radiation. The input laser beam enters the instrument through a fiber optic connector on the front panel. After collimation, the beam is directed into the Michelson interferometer. At the beamsplitter, the input beam is divided into two beams that follow separate optical paths. One beam reflects off of the moving retro-reflector assembly and returns to the beamsplitter. The other beam reflects off of a fixed retroreflector and returns to the beamsplitter where it interferes with the first beam. The intensity reaching the input photodetector depends on the relative lengths of the two paths which govern whether constructive or destructive interference occurs at the beamsplitter. As the retro-reflector moves back and forth the detected intensity varies sinusoidally.

If the retro-reflector assembly moves a distance **d**, the number of fringes produced is given by the equation:

$$m\lambda = 4n_{\lambda}d$$

where: **m** is the number of fringes generated by the input laser
λ is the wavelength of input laser beam
n_λ is the refractive index of air at the wavelength **λ**.

The above equation can be used to determine the wavelength of the laser radiation in vacuum by measuring **d** very accurately while counting the number of fringes **m**, and substituting the refractive index of air.

The accuracy of such a measurement is limited to the precision in the measurement of **d** and our knowledge of **n_λ**. To determine **d** for high accuracy measurements, a reference HeNe laser with an accurately known wavelength is built into the instrument. The reference laser beam is directed along exactly the same path as the input laser through the Michelson interferometer, but in the opposite direction so it can be detected on a separate reference photodetector. For the reference laser beam, we can write the equation:

$$m_o \lambda_o = 4 n_o d$$

Combining the above two equations gives:

$$\lambda = \left[\frac{m_o}{m} \right] \left[\frac{n_\lambda}{n_o} \right] \lambda_o$$

Therefore, the wavelength of the input laser beam is equal to the ratio of the number of fringes recorded for each laser multiplied by a refractive index correction and the wavelength of the reference laser beam.

The accuracy of the wavelength measurement is dependent on the terms in the equation above:

m_o / m - this ratio is calculated from the number of fringes generated for each laser over the distance scanned by the retro-reflector assembly. If the fringes are accurately subdivided, the numerator and denominator do not have to be integers.

n_λ / n_o - this ratio accounts for the difference in optical distances traveled by two laser beams with different wavelengths. Such a dispersion correction is necessary to determine the wavelength relative to vacuum. It is dependent on the temperature, pressure and humidity of the air inside the interferometer.

λ_o - is the reference laser vacuum wavelength. Its absolute accuracy is fundamental to the accuracy of the measurement.

Accuracy

The accuracy of the instrument depends fundamentally on the absolute accuracy of the reference laser, but several other factors can affect the accuracy of the measured wavelength:

Fringe counting resolution: Computing a wavelength with high accuracy requires that the precision in the numerator and denominator of the count ratio (m_o/m) is statistically sufficient. For the count ratio to have high precision, the number of fringes counted must be large or the fringes must be accurately subdivided. The WA-1100 and WA-1600 use a specially designed counter circuit to divide the interferometer fringes more than one hundred times. This design ensures that the counting statistics are always much higher than the number of fringes.

Dispersion in the Refractive Index of Air: The vacuum wavelength of the input radiation is computed from the vacuum wavelength of the reference laser by correcting for the dispersion (n_λ/n_o) in the refractive index of air. In the WA-1100 and WA-1600, the dispersion correction for temperature and pressure is calculated from the revised Edlén equation from Birch and Downs (*Metrologia*, 30, 155 (1993)). If the temperature, pressure and humidity of the air are known, these calculations have an accuracy of better than 5 parts in 10^8 at wavelengths between 600 and 1700 nm.

The temperature and pressure are measured inside the instrument and a correction factor is applied when computing the wavelength. Although humidity is taken into account in the index calculation, its effect is negligible in the infrared.

For reference, the error in parts per million (ppm) introduced by errors in the temperature, pressure, or humidity is given approximately by:

$$\Delta(n_\lambda/n_0) = 0.01\Delta T - 0.004 \Delta \text{ ppm}$$

where:

ΔT is the temperature error in °C

ΔP is the barometric pressure error in mm Hg

Alignment: An accurate measurement depends on the reference laser beam and the input laser beam passing along exactly the same path through the Michelson interferometer. The fiber optic input connector is prealigned to ensure that the alignment error is less than 1 part in 10^7 .

Diffraction: If an aperture anywhere along the laser beam path is made small, diffraction will change the direction of the light passing through the Michelson interferometer, possibly causing an additional error. No small apertures are incorporated in the WA-1100 and WA-1600 that would introduce diffraction errors greater than 1 part in 10^7 for any of the wavelength ranges.

Coherence: In order to achieve a high accuracy wavelength measurement, the bandwidth of the laser radiation must be narrow. This is because the generation of interference fringes by a Michelson interferometer is dependent upon the coherence length: $L_c = (2\pi \Delta\nu)^{-1}$, which is inversely proportional to the bandwidth ($\Delta\nu$) in cm^{-1} .

A narrow bandwidth laser, with a coherence length greater than a few centimeters, generates a sufficient number of interference fringes to achieve the highest accuracy. If the laser bandwidth is increased, resulting in a shorter coherence length, the number of fringes that can be counted is reduced.

A low coherence laser source may have a broad linewidth or operate simultaneously on two or more closely spaced lines. Three examples of Michelson interferometer fringe patterns for different laser spectra are depicted in Figure 4-1, Figure 4-2 and Figure 4-3.

The instrument has a Monitor port on the rear panel where signals like these corresponding to the actual input laser can be observed on an oscilloscope.

In these figures, the digital logic signals labeled Trigger, Zero Optical Path (ZOP), and Window below each fringe pattern identify the timing and extent of each measurement interval. These 5 volt logic signals can also be observed at the Monitor port. Trigger defines the largest measurement range possible for the particular instrument model. The rising transition of the ZOP signal defines the point in the scan where the two arms of the interferometer are exactly equal in optical path length. The envelope of the fringe pattern will always exhibit a maximum amplitude at the ZOP point, independent of the linewidth or mode structure. Window is a signal that identifies where the envelope of the fringe signal exceeds approximately 1 volt p-p amplitude. After a Window occurs that includes the ZOP point, no further Windows will be generated. When multiple Windows occur, such as in Figure 4-3, only one “Valid Window” that includes the ZOP point is used in the measurement.

A narrow linewidth laser produces fringes throughout the entire Trigger interval as shown in Figure 4-3. In this case, the Window interval is the maximum length allowed by the Trigger interval, and the highest precision measurement is made.

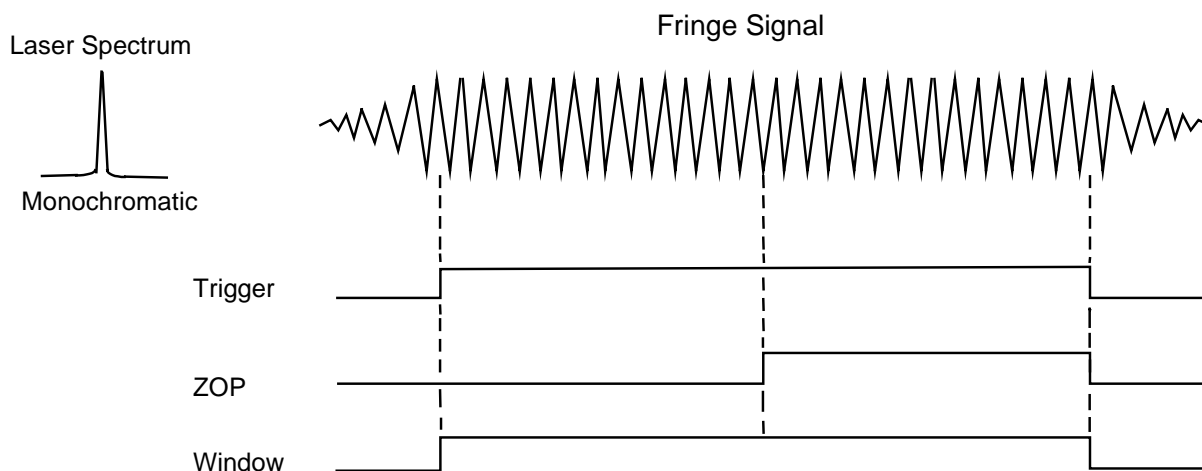

Figure 4-1. Fringe signal and measurement window for a monochromatic input laser with a narrow linewidth

Figure 4-2 shows that when the laser linewidth is broad, the envelope of the fringes does not extend as far as the Trigger interval on either side of the ZOP point. The Window interval is shortened to include only the number of fringes with sufficient amplitude to be reliably counted and the precision of the measurement is reduced accordingly.

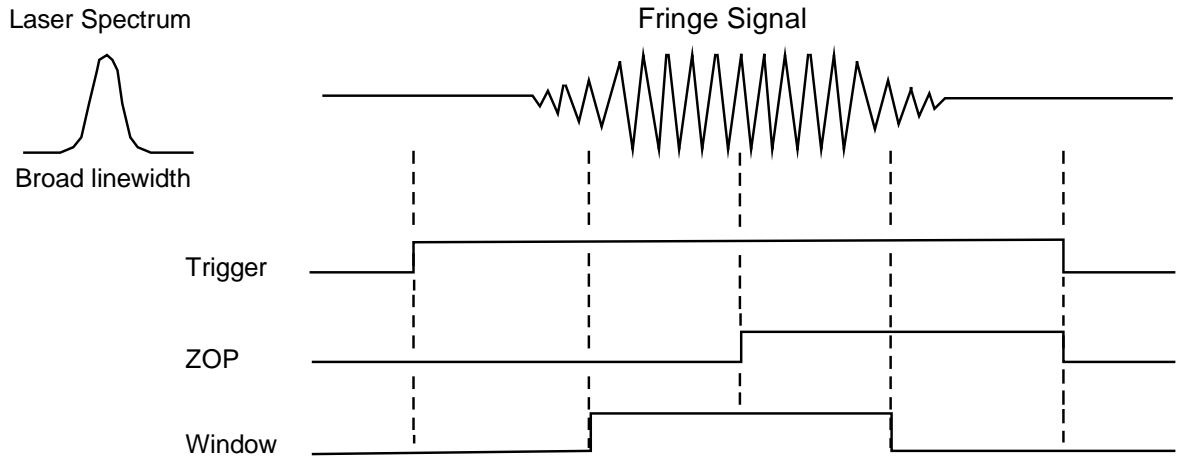

Figure 4-2. Fringe signal and measurement window for a broad linewidth input laser

Figure 4-3 shows an example of a bi-modal laser with two strong spectral lines. This laser produces a fringe pattern that exhibits beating between the two laser frequencies. Since the fringe amplitude goes to zero on either side of the ZOP, only the center fringe envelope can be used. Prior to the valid Window surrounding the ZOP point, other windows may occur but these are ignored for measurement purposes.

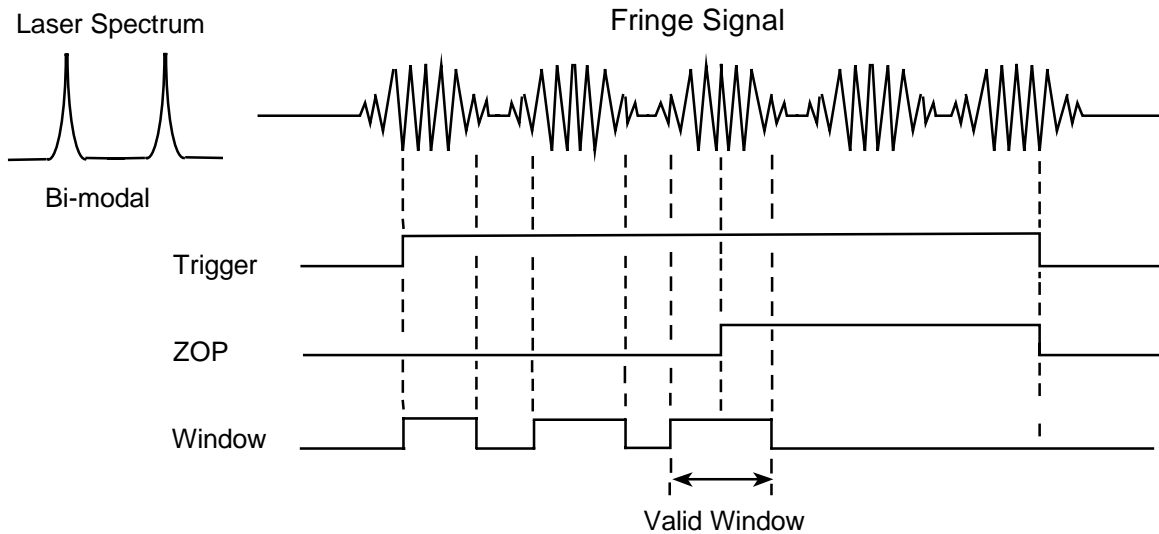

Figure 4-3. Fringe signal and measurement window for a bi-modal input laser

When the number of fringes is reduced by increased bandwidth or lack of coherence in the laser source, the accuracy of the wavelength measurement is also reduced. Typically, an increased bandwidth limits the accuracy of measurement to about 10% of the laser bandwidth for a single broad line as in Figure 4-2 or to 10% of the mode separation in a multi-mode laser spectrum as in Figure 4-3. When a laser has a complex mode structure, the measurement precision will be about 10% of the effective bandwidth and the wavelength reported will correspond to the intensity weighted average of the spectral distribution.

The WA-1100 and WA-1600 have an Auto-resolution feature that automatically adjusts the precision of the wavelength or frequency measurement according to the laser bandwidth. Insignificant digits after the decimal point are eliminated. If insignificant digits occur ahead of the decimal point they are replaced by the “x” character on the display. The reduction in resolution and number of digits displayed is demonstrated in Table 4-4.

Table 4-4. Auto-resolution as a function of laser bandwidth.

Laser Bandwidth ($\Delta\nu$)	Coherence Length (L_c)	Auto-resolution Display
$\Delta\nu \leq 1.5$ GHz (WA-1600 only)	> 32 mm	0.0001 nm
$\Delta\nu \leq 15$ GHz	> 3.2 mm	0.001 nm
$\Delta\nu \leq 150$ GHz	> 0.32 mm	0.01 nm

Accuracy Verification

Each WA-1100 and WA-1600 has been verified with a DFB diode laser locked to the R(3) band of acetylene ($^{12}\text{C}_2\text{H}_2$). The center of this absorption line has been characterized to 196,832.341 GHz +/- 150 KHz by K. Nakagawa et al. in "Accurate optical frequency atlas of the 1.5m bands of Acetylene", JOSA, B, 13, 2708 (1996) using an absorption line of Rubidium as the reference standard. The absorption line along with the laser's frequency locking circuit has been characterized to provide accuracy verification to within the limits required to verify the average wavelength reading to the accuracy specified for each model.

Calibration

As described earlier, accuracy is assured by the built-in continuous calibration from the on-board internal reference laser. In effect, the instrument is self-calibrating and can be expected to give years of accurate data. However, factors such as alignment can affect wavelength measurement. Although the rugged and compact optical housing is designed to minimize misalignments or other factors affecting accuracy due to aging and repeated handling, you may choose to consider a factory reverification. The decision to verify, if at all, depends on your existing procedures considering industry certifications such as ISO. If you do not have such procedures in place, consider the tradeoff between the time and cost of reverification versus data uncertainty and discuss these with your EXFO representative.

Appendix A. Specifications & Labeling

This Appendix provides specifications, dimensional drawings and labeling information.

Table A-1. Specifications

	WA-1100	WA-1600
Accuracy	±1 ppm (± 1.5 pm @ 1550 nm)	±0.2 ppm (± 0.30 pm @ 1550 nm)
Resolution (Display)	0.001 nm	0.0001 nm
Input Sensitivity	-30 dBm (1µW) 1200 - 1700 nm, -20 dBm below 1200 nm	
Max Input Power	10 dBm (10 mW)	
Optical Power Measurement		
Accuracy	±0.5dB (±10%)	
Resolution	±0.05dB (±1%)	
Max. Input Power	10 mW (100mW with external attenuator)	
General		
Design	Scanning Michelson interferometer design	
Input	Fiber Optic Coupler, FC/APC standard	
Wavelength Range	700-1700 nm	
Measurement Rate	10 per second	1 per second
Temperature Range	15-30 °C (ambient temperature)	
Pressure Range	500 - 900 mm Hg	
Dimensions	417 mm × 356 mm × 89 mm	
Communications Interface	RS-232 and IEEE 488.2 standard	
Electrical Power Consumption	45 Watts at 110 V	60 Watts at 110 V
Weight	12 Kg (25 lbs)	
Power Requirements	90-260 VAC, 50/60 Hz	
Fuse	2A, 250 V, time-delay, 5 x 20mm (1/4" x 1 1/4")	

*Sensitivity defines the optical input power required over most of the wavelength range. More power may be necessary at either end of the range, depending on the photodetector.

Dimensional Drawing

Figure A-1. Dimensions

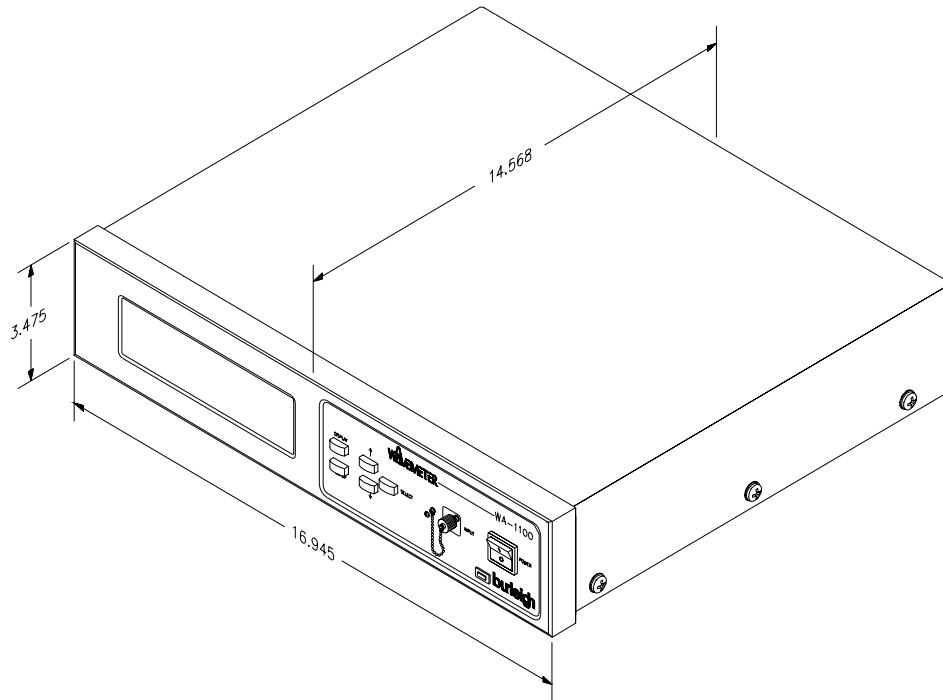

Rack Mounting Option

The WA-1100/1600 can be mounted in a standard 19" electronics rack by attaching the rack mounting brackets as shown below.

When the WA-1100/1600 is mounted in an enclosed rack, be careful not to block the fan on the rear panel and provide adequate ventilation inside the rack to prevent overheating.

For proper fit, you may want to remove the feet under the chassis.

CAUTION If you remove the feet, **DO NOT** reinsert the screws or damage to the internal components of the wavemeter can occur.

Appendix B. Warranty & Service

Warranty

The WA-1100 and WA-1600 are warranted against defects in material and workmanship for a period of one year after date of delivery. Optical components are warranted for 90 days. During the warranty period, EXFO will repair, or at its option, replace parts that prove to be defective when the instrument is returned prepaid to EXFO. **Before returning an instrument always call EXFO for return authorization.** The warranty will not apply if the instrument has been damaged by accident, misuse, or as a result of modification by persons other than **EXFO** personnel.

It is important to call EXFO or your local sales representative in advance of returning a unit, for a Return Authorization Number (RA#). This will ensure the prompt handling of the repair, as well as provide important tracking information.

The liability of EXFO, (except as to title) arising out of supplying of said product, or its use, whether under the foregoing warranty, a claim of negligence, or otherwise, shall not in any case exceed the cost of correcting defects in the products as herein provided. Upon expiration of the warranty period specified herein, all liability shall terminate. The foregoing shall constitute the sole remedy of the buyer. In no event shall the seller be liable for consequential or special damages.

Service

There are no user serviceable parts inside the WA-1100 and WA-1600. Adjusting parts inside the instrument can affect the accuracy of the instrument. If you adjust parts, you will need to verify the accuracy of the measurements.

Appendix C. Error & Status Messages

The instrument continually checks the quality of the signal it is analyzing and reports messages for any unusual conditions that might affect the precision of the measurement. There are two types of messages. In most cases, Error Messages will prevent data from being reported. These are displayed in the Display Screens. The error messages will also be reported as Status Messages that will be reported in the Status Screen or can be queried through remote communications. Some other status messages may not prevent data from being reported, and indicate that there may be unusual operation of the laser under test and are to simply caution the user that a problem may exist.

Error Messages

In the following table, the error messages are described with a cross-reference to the status screen reference code. The error messages are shown in order of how they would appear if there were multiple errors.

Table C-1. Error Messages

Display Message	Cause/Solution	Status Screen Reference
"Loading Default Settings"	Indicates the original calibration and set-up data has been corrupted and default values will be used.	none
"Reference Laser: Over Temperature"	WA-1600 only. The reference laser stabilization circuit is indicating an over temperature condition. Turn the instrument off, wait 15 minutes and power up again. If the problem persists, contact EXFO Service.	00000002
"Reference Laser: Calibration Error"	WA-1600 only, reference laser peak power outside of 60-85% range necessary for proper operation. Recalibration is necessary. Contact EXFO Service.	00040000
"Reference Laser: Not Stabilized"	WA-1600 only. This message is normal on power up for up to 7 minutes. The display shows warm-up time. Turning power off and on again will restart the warm-up timer. If this condition occurs after initial warm-up then contact EXFO Service.	00000001
"Scan Engine: No Trigger"	Interferometer scan motion error. Either the scan assembly is not moving or the scan timing detector is malfunctioning. Contact EXFO Service.	00000080
"Temperature/Pressure Sensor: Out of Range"	The pressure or temperature reading is out of range; the normal pressure range is 500 mm Hg to 900 mm Hg and the normal temperature range is 1°C to 50°C. A temperature or pressure reading of 0 usually indicates the sensor is not connected or has a broken wire. Contact EXFO Service.	00001000 and 00002000
"Reference Laser: No Fringes Detected"	Detector failure or insufficient signal amplitude from the reference laser. This may be due to a decrease in reference laser power or a major misalignment of the internal optics. Contact EXFO Service.	00000004
"Input Laser: Intensity Too Low"	The input laser signal observed at the Monitor output must exceed 1.5 volts p-p amplitude. Set gain to auto. Check input laser power. Increase the intensity of the input laser beam entering the instrument.	00000100
"Input Laser: Wavelength Out Of Range"	Check that the laser is operating within the specified wavelength range: 700-1700 nm.	00008000

Status Messages

The following table describes the complete set of status messages that can appear in the status screen. The messages are listed in numerical order.

Table C-2. Status Messages

Status Message	Description	Solution
	Load default settings	Indicates the original calibration and set-up data has been corrupted and default values will be used.
00000001	WA-1600 only, reference laser is not stabilized.	This message is normal on power up of the WA-1600. The display shows warm-up time. Turning power off and on again will restart the warm-up timer. If this condition occurs after initial warm-up then contact EXFO Service.
00000002	WA-1600 only, reference laser is over temperature.	The laser stabilization circuit is indicating an over temperature condition. Turn the instrument off, wait 15 minutes and power up again. If the problem persists, contact EXFO Service.
00000004	Detector failure or insufficient signal amplitude from the reference laser.	This may be due to a decrease in reference laser power or a major misalignment of the internal optics. Contact EXFO service.
00000008	Intermittent signal from the reference laser during the measurement window.	Reference laser signal at the Monitor output should exceed 2.0 volts p-p throughout the measurement window. This may be due to partial misalignment of the instrument internal optics.
00000020	EEPROM read failure. Problem occurs on power up or when restoring.	Turn the instrument off, wait a few moments, and turn the instrument back on. If the problem persists contact EXFO Service.
00000040	Static RAM read/write failure. This error may sometimes occur on power up.	Turn the instrument off, wait a few moments, turn the instrument back on. If the problem persists contact EXFO Service.
00000080	Interferometer scan motion error.	Either the scan assembly is not moving or the scan timing detector is malfunctioning. Contact EXFO Service.
00000100	Input signal (fringe amplitude) is too low.	The input laser signal observed at the Monitor output must exceed 1.5 volts p-p amplitude. Set gain to auto. Check input laser power. Increase the intensity of the input laser beam entering the instrument.
00000200 00000400 00000800	Counting errors.	Check input laser for intensity or frequency instability. If the error persists, contact EXFO Service.
00001000	Pressure reading is out of range; range is 500 mm Hg to 900 mm Hg.	If the problem persists contact EXFO Service.

00002000	Temperature reading is out of range; range is 1°C to 50°C.	A temperature reading of 0°C usually indicates the temperature sensor is not connected or has a broken wire. If the problem persists contact EXFO Service.
00004000	Input Laser Power error, power is out of range	Check that the laser is operating within the specified power range. If no wavelength is indicated, then 1550 nm is assumed in the power calculation.
00008000	The wavelength (or frequency) measurement is out of the range for the model setting.	Check that the laser is operating within the specified wavelength range: 700-1700 nm.
00010000	Power Null failure.	The background power reading is above the threshold for the power null function. Make sure an input laser is removed from the instrument and the fiber connector cap is on.
00040000	WA-1600 only, reference laser peak power outside of 70-80% range necessary for proper operation.	Recalibration is necessary. Contact EXFO Service.
00080000	Input power too high.	Check if input laser is above the specified maximum input power.
00100000 00200000 00400000 00800000	Internal communications error.	If persistent, contact EXFO Service

Appendix D. Rear Panel Controls

GPIB Port

The instrument has a GPIB communications port on the back panel as shown in Figure D-1. The GPIB port uses the standard IEEE-488 connector, with the pinout described in Table D-1.

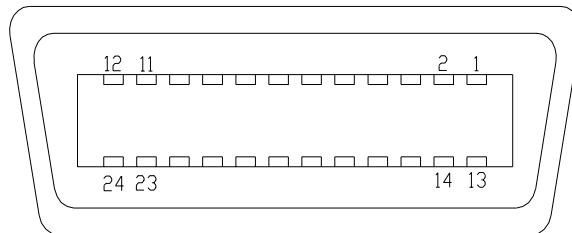

Figure D-1. GPIB Interface Connector

Table D-1. Standard IEEE-488 Connector Pinout

Pin Number	Signal Name	Pin Number	Signal Name
1	DIO1	13	DIO5
2	DIO2	14	DIO6
3	DIO3	15	DIO7
4	DIO4	16	DIO8
5	EOI	17	REN
6	DAV	18	GND (TW W/ DAV)
7	NRFD	19	GND (TW W/ NRFD)
8	NDAC	20	GND (TW W/ NDAC)
9	IFC	21	GND (TW W/ FC)
10	SRQ	22	GND (TW W/ SRQ)
11	ATN	23	GND (TW W/ ATN)
12	SHIELD	24	SIGNAL GROUND

RS-232 Serial Interface Connector

The RS-232 port is a 9-pin, female, D-sub style connector, with the pinout described in Table 3-1. The connector housing provides connection to the earth ground inside the instrument.

The pin configuration complements that of the PC/AT. To connect the instrument to a PC/AT, use a serial extension cable with 1:1 pin correlation. To facilitate the connecting of the serial port, use the signal descriptions (H = Active).

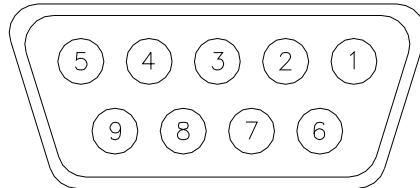

Figure D-2. RS-232 Serial Interface Connector

Table D-2. RS-232 Serial Port Pinout

Pin Number	Signal Name	Signal Source	Description
1	-	-	N/C
2	TxD	WA-1100/1600	Transmit Data. Data from the instrument is output on this signal pin.
3	RxD	User	Receive Data. Data from the user is received on this signal pin.
4	DSR	User	Data Set Ready. This input signal must be held active by the user for the instrument to consider the serial port connected to an external device.
5	GND	-	Signal Ground. Required for proper RS-232 operation.
6	DTR	WA-1100/1600	Data Terminal Ready. This output signal is active whenever the instrument is powered and is not in internal reset.
7	CTS	User	Clear To Send. An input signal indicates to the instrument when the user device is able to accept additional data.
8	RTS	WA-1100/1600	Request To Send. The instrument makes this signal active as long as its internal command buffer has room in it. When the internal command buffer is full, the instrument sets RTS inactive.
9	-	-	N/C

Signal Monitor Connector

The Signal Monitor connector on the back panel of the instrument provides a combination of analog and digital signals for observing the fringe signals and measurement timing signals using an oscilloscope. The signals have the characteristics described in Table D-1.

The Signal Monitor output is a 15-pin, female, D-sub style connector shown in Figure D-1 and with the pinout described in Table D-2.

Examples of these signals for different input laser characteristics are described and shown in Section 4 of this manual.

Table D-3. Signal Monitor Characteristics

	Analog Signals	Digital (TTL) Signals
Output Voltage	± 7 V maximum	$V_{OL} = 0.4V$ max, $V_{OH} = 2.4V$ min
Output Current	100 mA maximum	$I_{OL} = 16$ mA max, $I_{OH} = -0.4$ mA
Output Timing	NA	$t_r \leq 7$ nsec, $t_f \leq 7$ nsec

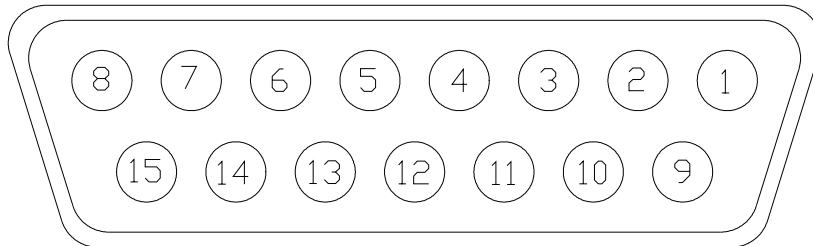

Figure D-3. Signal Monitor Output Connector

Table D-4. Monitor Pinout

Pin Number	Signal Name	Signal Type	Description
1	INPUT	Analog	Input laser sinusoidal fringe signal.
2	REFERENCE	Analog	Reference laser sinusoidal fringe signal.
3	VREF	TTL	Valid reference laser fringe amplitude.
4			ZOP1 Raw
5	TRIGGER	TTL	Scanning Window Trigger is a digital pulse with a duration that defines the maximum measurement interval for the interferometer scan. It goes active (H = active) during the allowed measurement interval.
6	DGND	-	Digital Ground
7			1 TRIG
8	ZOP	TTL	Zero Optical Path (ZOP) is a digital pulse derived from the interferometer scanner that produces a low to high transition at the point in the scan where the difference between the two optical paths in the interferometer is zero.
9	AGND	-	Analog Ground
10	AGND	-	Analog Ground
11			N/C
12			N/C
13			N/C
14	DGND	-	Digital Ground
15	WINDOW	TTL	Scanning Window digital output is derived from the amplitude of the input laser fringe signal. When the p-p amplitude of this signal exceeds 1 volt, within the Trigger interval and before or spanning the ZOP transition, the Window is active (H = active). Depending on the character of the input laser fringes, there may be several Windows during a Trigger, but the first Window period to terminate after the ZOP transition is the only "Valid Window" used for the measurement.

Index

- A**
- accuracy, 4-2
 - Address of GPIB port, 2-6
 - Auto
 - gain, 2-4, 2-5
 - resolution, 2-5
 - Average, 2-4, 2-5
 - Avg, 2-4
- B**
- Baud, 2-6
 - Brightness, 2-6
- C**
- change display information, 2-2
 - Cleaning
 - Fan Filter, 1-4
 - Fiber End, 1-3
 - Cleaning a Fiber Optic Connector, 1-3
 - Cleaning a Universal Connector, 1-3
 - Cleaning, fiber end, 1-3
 - Commands
 - CALCulate, 3-10
 - DISPlay, 3-12
 - Measurement, 3-8
 - SENSE, 3-14
 - STATus, 3-16
 - SYSTem, 3-18
 - TRIGger, 3-19
 - UNIT, 3-20
 - Communications setup screen, 2-5
 - components, 1-2
 - Configuration setup screen, 2-5
 - connector
 - GPIB, D-1
 - monitor, D-2
 - RS-232, D-2
- D**
- display
 - on instrument, 2-1
 - screens, 2-3
 - DISPLAY Button, 2-1
- E**
- Error Message, 2-4
 - error messages, C-1
- F**
- Fan Filter Cleaning, 1-4
 - Fiber End Cleaning, 1-3
 - Fiber Optic Connector, 1-3
 - Fixed gain, 2-4, 2-5
 - front panel, 2-1
- G**
- Gain, 2-4, 2-5
 - GPIB
 - connector, D-1
 - enable/disable, 2-6
- H**
- Handshaking, 2-6
- I**
- IEEE-488, D-1
 - Information setup screen, 2-5
- L**
- laser power current, 2-4
 - lockout. *See* Remote Lockout
- M**
- Main display screen, 2-3
 - Medium, 2-4
 - monitor signal, D-2
- P**
- Poffs, 2-4
 - Power, 2-4
 - current, 2-4
 - display screen, 2-3
 - offset, 2-4, 2-5
 - switch, 2-1
 - Power Null, 2-5
- R**
- Rack Mounting Option, A-2
 - Remote Lockout, 2-2, 2-6
 - Reset, 2-4
 - Resolution, 2-5
 - Restore All, 2-6
 - restore parameters, 2-2
 - return authorization, B-1
 - RS-232
 - connector, D-2
 - enable/disable, 2-6
- S**
- Save All, 2-6
 - save parameters, 2-2

- SCPI, 3-1
 - screens
 - display, 2-3
 - setup, 2-5
 - SELECT Button, 2-1
 - service, B-1
 - set up instrument, 1-2
 - SETUP Button, 2-1
 - Setup screens, 2-5
 - signal
 - GPIB, D-1
 - monitor, D-2
 - RS-232, D-2
 - specifications, A-1
 - standard air, 2-4
 - Status screen, 2-5
- U**
- units. *See* specific parameter's units
 - Universal Connector, 1-3
- V**
- vacuum, 2-4
 - Vacuum, 2-4
- W**
- warranty, B-1
 - Wavelength
 - current, 2-4
 - display screen, 2-3
- X**
- Xon/Xoff, 2-6

Declaration of Conformity

Manufacturer's Name: EXFO Burleigh Products Group Inc.

Manufacturer's Address: 7647 Main St. Fishers
Victor, NY 14564-8909
USA

declares this product:

Product Name: Wavemeter

Model Number(s): WA-1100
WA-1600

conforms to the following standards:

Safety: EN-61010-1: IEC 1010-1

EMC: EN-50081-1: EN-55011; Group 1, Class A : Emissions
EN-50082-1: IEC 1000-4-2: ESD Immunity; 2kV CD, 2kV AD
IEC 1000-4-3: RFI Immunity; 3V/m, 27-500 MHz, Class II
IEC 1000-4-4: Electrical Fast Transient Immunity; 0.5 kV
IEC 1000-4-5: High Voltage Surge Immunity; 0.5 kV

Supplementary Information: "The product complies with the requirements of the **Low Voltage Directive 73/23/EEC** and the **EMC Directive 89/336/EEC**."

European Sales Office: Scientifica Ltd.
9 Allied Business Center, Coldharbour Lane
Harpenden, Herts, AL5 4UT, UK

Date of Issue: September, 1998



signed:

A handwritten signature in black ink that reads "David J. Farrell pres." The signature is written in a cursive style and is underlined.

David J. Farrell, President



EXFO Burleigh Products Group Inc.
7647 Main Street Fishers
Victor, NY 14564-8909
Tel. (585) 924-9355
Fax. (585) 924-9072

WA1100/1600
08115-M-00



Artisan Technology Group is your source for quality new and certified-used/pre-owned equipment

- FAST SHIPPING AND DELIVERY
- TENS OF THOUSANDS OF IN-STOCK ITEMS
- EQUIPMENT DEMOS
- HUNDREDS OF MANUFACTURERS SUPPORTED
- LEASING/MONTHLY RENTALS
- ITAR CERTIFIED SECURE ASSET SOLUTIONS

SERVICE CENTER REPAIRS

Experienced engineers and technicians on staff at our full-service, in-house repair center

*InstraView*SM REMOTE INSPECTION

Remotely inspect equipment before purchasing with our interactive website at www.instraview.com ↗

WE BUY USED EQUIPMENT

Sell your excess, underutilized, and idle used equipment. We also offer credit for buy-backs and trade-ins. www.artisanng.com/WeBuyEquipment ↗

LOOKING FOR MORE INFORMATION?

Visit us on the web at www.artisanng.com ↗ for more information on price quotations, drivers, technical specifications, manuals, and documentation

Contact us: (888) 88-SOURCE | sales@artisanng.com | www.artisanng.com