



## Artisan Technology Group is your source for quality new and certified-used/pre-owned equipment

- FAST SHIPPING AND DELIVERY
- TENS OF THOUSANDS OF IN-STOCK ITEMS
- EQUIPMENT DEMOS
- HUNDREDS OF MANUFACTURERS SUPPORTED
- LEASING/MONTHLY RENTALS
- ITAR CERTIFIED SECURE ASSET SOLUTIONS

### SERVICE CENTER REPAIRS

Experienced engineers and technicians on staff at our full-service, in-house repair center

### *InstraView*<sup>SM</sup> REMOTE INSPECTION

Remotely inspect equipment before purchasing with our interactive website at [www.instraview.com](http://www.instraview.com) ↗

### WE BUY USED EQUIPMENT

Sell your excess, underutilized, and idle used equipment. We also offer credit for buy-backs and trade-ins. [www.artisanng.com/WeBuyEquipment](http://www.artisanng.com/WeBuyEquipment) ↗

### LOOKING FOR MORE INFORMATION?

Visit us on the web at [www.artisanng.com](http://www.artisanng.com) ↗ for more information on price quotations, drivers, technical specifications, manuals, and documentation

**Contact us:** (888) 88-SOURCE | [sales@artisanng.com](mailto:sales@artisanng.com) | [www.artisanng.com](http://www.artisanng.com)

# Installation Manual



## TLA 700 Series Logic Analyzer

**070-9774-02**

### **Warning**

The servicing instructions are for use by qualified personnel only. To avoid personal injury, do not perform any servicing unless you are qualified to do so. Refer to all safety summaries prior to performing service.

Copyright © Tektronix, Inc. All rights reserved. Licensed software products are owned by Tektronix or its suppliers and are protected by United States copyright laws and international treaty provisions.

Use, duplication, or disclosure by the Government is subject to restrictions as set forth in subparagraph (c)(1)(ii) of the Rights in Technical Data and Computer Software clause at DFARS 252.227-7013, or subparagraphs (c)(1) and (2) of the Commercial Computer Software – Restricted Rights clause at FAR 52.227-19, as applicable.

Tektronix products are covered by U.S. and foreign patents, issued and pending. Information in this publication supercedes that in all previously published material. Specifications and price change privileges reserved.

Printed in the U.S.A.

Tektronix, Inc., P.O. Box 1000, Wilsonville, OR 97070–1000

TEKTRONIX and TEK are registered trademarks of Tektronix, Inc.

## TEKTRONIX SERVICE OPTIONS

Tektronix offers the following service options. These options are modular, flexible, and easy to order with your instrument. Designed to ease installation and start up, to support tracking of calibration to requirements of ISO9000, and to provide for extended repair coverage, these options help fix your long-term maintenance costs and eliminate unplanned expenditures. And these options can be converted from service at Tektronix service depots to service on-site (see Option S3), which helps keep downtime to a minimum.

Product installation service <sup>1</sup>	Option IN	Provides initial installation of the product and familiarizes new users with some of its operation features
Three years of calibration services	Option C3	Provides initial Certification on delivery, plus two more annual calibrations from your service center
Test data	Option D3	Provides test data on delivery and when annual calibration services are provided (three total, requires Option C3)
Three years repair coverage	Option R3	Provides three years of repair coverage for the instrument, including displays and accessories sold with the instrument
One year uplift to on-site service <sup>1,2</sup>	Option S1	Converts the standard one year, “return to depot” warranty to provide service on site for one year
Three year uplift to on-site service <sup>1,2</sup>	Option S3	Converts any C3, D3, and R3 options purchased to on-site services for three years

Tektronix Service Options are available at the time you order your instrument. Contact your local Tektronix Sales Office for more information.

<sup>1</sup> Availability of installation and on-site services depends on the type of product and may vary by geography.

<sup>2</sup> Uplift options are ordered with the mainframe products and cover individual modules.



# Table of Contents

<b>General Safety Summary</b> .....	<b>v</b>
<b>Service Safety Summary</b> .....	<b>vii</b>
<b>Preface</b> .....	<b>ix</b>
Related Documentation .....	x
Service Offerings .....	xi
Contacting Tektronix .....	xii
<b>Basic Installation</b> .....	<b>1</b>
Check the Shipping List .....	1
Check the Environmental Requirements .....	2
Install the Modules .....	5
Cover Empty Slots .....	6
Connect the Standard and Other Accessories .....	7
Connect the Probes .....	9
Power On the Logic Analyzer .....	10
Powering Off the Logic Analyzer .....	12
Perform the Incoming Inspection .....	12
Create an Emergency Startup Disk .....	13
Back Up User Files .....	13
<b>Installing Microprocessor Support Software</b> .....	<b>15</b>
<b>The Next Step</b> .....	<b>17</b>
Online Help .....	17
TLA 700 Series QuickStart Training Board and Manual .....	17
Other Documentation .....	17
<b>In Case of Problems</b> .....	<b>19</b>
Diagnostics .....	19
Software Problems .....	20
Hardware Problems .....	20
TLA 700 Startup Sequence .....	23
Replacing Podlets on the P6417 Logic Analyzer Probe .....	25
<b>Appendix A: Merging Logic Analyzer Modules</b> .....	<b>33</b>
Equipment Required .....	33
Merge Procedure .....	33
Installing the Merged Modules in the Logic Analyzer .....	37
Removing Merged Modules from the Logic Analyzer .....	38
Storing the Merge Cable .....	38
<b>Appendix B: Upgrades</b> .....	<b>41</b>
Upgrading Software .....	41
Installing TPI .....	43
Updating Module Firmware .....	50
Controller BIOS Setup .....	52
Reinstalling Software .....	56
Customizing TLA 700 Series Setups .....	61
<b>Appendix C: Power Cord and Line Fuse Requirements for the   Benchtop Mainframe</b> .....	<b>65</b>

## List of Figures

<b>Figure 1: Location of ground connections</b> .....	<b>4</b>
<b>Figure 2: Installing modules</b> .....	<b>5</b>
<b>Figure 3: Installing the empty slot panel covers</b> .....	<b>6</b>
<b>Figure 4: Locations of external connectors</b> .....	<b>7</b>
<b>Figure 5: Connecting the logic analyzer probes</b> .....	<b>9</b>
<b>Figure 6: Line fuse and power cord connector locations</b> .....	<b>10</b>
<b>Figure 7: On/Standby switch locations</b> .....	<b>11</b>
<b>Figure 8: TLA 700 startup sequence</b> .....	<b>24</b>
<b>Figure 9: Moving probe podlets</b> .....	<b>25</b>
<b>Figure 10: Disassembling the probe cable</b> .....	<b>27</b>
<b>Figure 11: Removing the faulty channel from the probe cable header housing</b> .....	<b>28</b>
<b>Figure 12: Removing a podlet cable from the rubber comb</b> .....	<b>29</b>
<b>Figure 13: Replacing a podlet in the podlet holder</b> .....	<b>30</b>
<b>Figure 14: Installing the color-coded ring</b> .....	<b>31</b>
<b>Figure 15: Installing the cable in the cable header housing</b> .....	<b>32</b>
<b>Figure 16: Removing the cover</b> .....	<b>34</b>
<b>Figure 17: Feeding the Merge cable through the cover</b> .....	<b>35</b>
<b>Figure 18: Seating the cover on the chassis</b> .....	<b>36</b>
<b>Figure 19: Lining up the two modules</b> .....	<b>37</b>
<b>Figure 20: Dressing the Merge cable before installing the cover</b> ....	<b>39</b>
<b>Figure 21: Flash programming pins</b> .....	<b>50</b>
<b>Figure 22: Power cord identification chart</b> .....	<b>66</b>

## List of Tables

<b>Table 1: Mainframe operating requirements .....</b>	<b>3</b>
<b>Table 2: Additional accessory connection information .....</b>	<b>8</b>
<b>Table 3: Line fuses .....</b>	<b>10</b>
<b>Table 4: Troubleshooting .....</b>	<b>21</b>
<b>Table 5: Software not covered by the TLA 700 Series software setup</b>	<b>41</b>
<b>Table 6: Controller BIOS setups for the TLA 700 application .....</b>	<b>53</b>
<b>Table 7: Power for instrument modules .....</b>	<b>65</b>





# General Safety Summary

Review the following safety precautions to avoid injury and prevent damage to this product or any products connected to it. To avoid potential hazards, use this product only as specified.

*Only qualified personnel should perform service procedures.*

While using this product, you may need to access other parts of the instrument. Read the *General Safety Summary* in other system manuals for warnings and cautions related to operating the system.

## To Avoid Fire or Personal Injury

**Use Proper Power Cord.** Use only the power cord specified for this product and certified for the country of use.

**Connect and Disconnect Properly.** Do not connect or disconnect probes or test leads while they are connected to a voltage source.

**Ground the Product.** This product is indirectly grounded through the grounding conductor of the mainframe power cord. To avoid electric shock, the grounding conductor must be connected to earth ground. Before making connections to the input or output terminals of the product, ensure that the product is properly grounded.

**Observe All Terminal Ratings.** To avoid fire or shock hazard, observe all ratings and marking on the product. Consult the product manual for further ratings information before making connections to the product.

The common terminal is at ground potential. Do not connect the common terminal to elevated voltages.

**Do Not Operate Without Covers.** Do not operate this product with covers or panels removed.

**Do Not Operate With Suspected Failures.** If you suspect there is damage to this product, have it inspected by qualified service personnel.

**Do Not Operate in Wet/Damp Conditions.**

**Do Not Operate in an Explosive Atmosphere.**

**Provide Proper Ventilation.** Refer to the manual's installation instructions for details on installing the product so it has proper ventilation.

## Symbols and Terms

**Terms in this Manual.** These terms may appear in this manual:



---

**WARNING.** Warning statements identify conditions or practices that could result in injury or loss of life.

---



---

**CAUTION.** Caution statements identify conditions or practices that could result in damage to this product or other property.

---

**Terms on the Product.** These terms may appear on the product:

**DANGER** indicates an injury hazard immediately accessible as you read the marking.

**WARNING** indicates an injury hazard not immediately accessible as you read the marking.

**CAUTION** indicates a hazard to property including the product.

**Symbols on the Product.** The following symbols may appear on the product:



WARNING  
High Voltage



Protective Ground  
(Earth) Terminal



CAUTION  
Refer to Manual



Double  
Insulated

# Service Safety Summary

Only qualified personnel should perform service procedures. Read this *Service Safety Summary* and the *General Safety Summary* before performing any service procedures.

**Do Not Service Alone.** Do not perform internal service or adjustments of this product unless another person capable of rendering first aid and resuscitation is present.

**Disconnect Power.** To avoid electric shock, disconnect the main power by means of the power cord or, if provided, the power switch.

**Use Caution When Servicing the CRT.** To avoid electric shock or injury, use extreme caution when handling the CRT. Only qualified personnel familiar with CRT servicing procedures and precautions should remove or install the CRT.

CRTs retain hazardous voltages for long periods of time after power is turned off. Before attempting any servicing, discharge the CRT by shorting the anode to chassis ground. When discharging the CRT, connect the discharge path to ground and then the anode. Rough handling may cause the CRT to implode. Do not nick or scratch the glass or subject it to undue pressure when removing or installing it. When handling the CRT, wear safety goggles and heavy gloves for protection.

**Use Care When Servicing With Power On.** Dangerous voltages or currents may exist in this product. Disconnect power, remove battery (if applicable), and disconnect test leads before removing protective panels, soldering, or replacing components.

To avoid electric shock, do not touch exposed connections.

**X-Radiation.** To avoid x-radiation exposure, do not modify or otherwise alter the high-voltage circuitry or the CRT enclosure. X-ray emissions generated within this product have been sufficiently shielded.



# Preface

The *TLA 700 Series Installation Manual* is intended to help you install your TLA 700 Series Logic Analyzer. Although your TLA 700 Series Logic Analyzer may arrive with all modules installed, you should still follow the steps in this manual to complete the installation process.

The manual consists of the following sections:

- *Basic Installation* describes the hardware installation process and provides information to start the logic analyzer the very first time.
- *Installing Microprocessor Support Software* describes the steps for installing microprocessor support software that does not come installed on your logic analyzer.
- *The Next Step* provides information on other TLA 700 Series documentation that you may need to operate your TLA 700 Series Logic Analyzer.
- *In Case of Problems* provides information on handling problems or difficulties that may occur during the installation process. It also provides procedures for replacing probe podlets and a list of phone numbers for Tektronix product support.
- *Appendix A: Merging Logic Analyzer Modules* provides the procedures for combining two logic analyzer modules to create a single, wider module.
- *Appendix B: Upgrades* provides information on upgrading software, installing TPI, (TLA 700 Programmatic Interface), upgrading firmware for the individual modules, and for using the BIOS setup for the controller in your logic analyzer.
- *Appendix C: Power Cord and Line Fuse Requirements for the Benchtop Mainframe* provides information on selecting the proper power cord and line fuse for the benchtop mainframe.

## Related Documentation

In addition to this installation manual, the following documentation is available for your TLA 700 Series logic analyzer:

- The *TLA 700 Series Logic Analyzer User Manual* provides basic operating information for the TLA 700 Series Logic Analyzer.
- The online help provides information about the TLA 700 Series user interface. To view the online help, select Help Topics from the Help menu.
- A series of microprocessor support instruction manuals provide operating and service instructions for the individual microprocessor support packages.
- The *TLA 7QS Training Manual* provides training exercises to help you learn key features of the TLA 700 Series Logic Analyzer. The training manual is designed to be used with the TLA 700 Series QuickStart training board.
- The *TLA 7QS Technical Reference Manual* provides technical and service information for the TLA 700 Series QuickStart training board.
- The *TLA 700 Series Performance Verification and Adjustment Technical Reference Manual* provides performance verification and adjustment procedures for the major components of the TLA 700 Series Logic Analyzer. The manual includes the performance verification and adjustment software.
- The *TLA 711 Color Benchtop Chassis Service Manual* provides module-level service information for the benchtop chassis.
- The *TLA 711 Color Benchtop Controller Service Manual* provides module-level service information for the benchtop mainframe controller module.
- The *TLA 704 Color Portable Mainframe Service Manual* provides module-level service information for the portable mainframe.
- The *TLA 7Lx/TLA 7Mx Logic Analyzer Service Manual* provides module-level service information for the logic analyzer module.
- The *TLA 7Dx/TLA 7Ex Digitizing Oscilloscope Service Manual* provides module-level service information for the DSO module.

## Service Offerings

Tektronix provides service to cover repair under warranty as well as other services that are designed to meet your specific service needs.

Whether providing warranty repair service or any of the other services listed below, Tektronix service technicians are well equipped to service the TLA 700 Series Logic Analyzers. Tektronix technicians train on Tektronix products; they have access to the latest information on improvements to the TLA 700 Series Logic Analyzers as well as the latest new product upgrades. *Services are provided at Tektronix Services Centers and on-site at your facility, depending on your location.*

### Warranty Repair Service

Tektronix warrants this product for one year from date of purchase. (The warranty appears behind the title page in this manual.) Tektronix technicians provide warranty service at most Tektronix service locations worldwide. The Tektronix product catalog lists all service locations worldwide or you can visit us on our *Customer Services World Center* web site at <http://www.tek.com/Measurement/Service>. See our latest service offerings and contact us by email.

### Calibration and Repair Service

In addition to warranty repair, Tektronix Service offers calibration and other services which provide cost-effective solutions to your service needs and quality-standards compliance requirements. Our instruments are supported worldwide by the leading-edge design, manufacturing, and service resources of Tektronix to provide the best possible service.

The following services can be tailored to fit your requirements for calibration and/or repair of the TLA 700 Series Logic Analyzers.

**Service Options.** Tektronix Service Options can be selected at the time you purchase your instrument. You select these options to provide the services that best meet your service needs. These service options are listed on the *Tektronix Service Options* page following the title page of this manual.

**Service Agreements.** If service options are not added to the instrument purchase, then service agreements are available on an annual basis to provide calibration services or post-warranty repair coverage for the TLA 700 Series Logic Analyzers. Service agreements may be customized to meet special turn-around time and/or on-site requirements.

**Service on Demand.** Tektronix also offers calibration and repair services on a “per-incident” basis that is available with standard prices for many products.



**Self Service.** Tektronix supports repair to the replaceable-part level by providing for circuit board exchange.

Use this service to reduce down-time for repair by exchanging circuit boards for remanufactured ones. Tektronix ships updated and tested exchange boards. Each board comes with a 90-day service warranty.

**For More Information.** Contact your local Tektronix service center or sales engineer for more information on any of the Calibration and Repair Services just described.

## Contacting Tektronix

Product Support	For application-oriented questions about a Tektronix measurement product, call toll free in North America: 1-800-TEK-WIDE (1-800-835-9433 ext. 2400) 6:00 a.m. – 5:00 p.m. Pacific time  Or contact us by e-mail: tm_app_supp@tek.com  For product support outside of North America, contact your local Tektronix distributor or sales office.
Service Support	Contact your local Tektronix distributor or sales office. Or visit our web site for a listing of worldwide service locations.  <a href="http://www.tek.com">http://www.tek.com</a>
For other information	In North America: 1-800-TEK-WIDE (1-800-835-9433) An operator will direct your call.
To write us	Tektronix, Inc. P.O. Box 1000 Wilsonville, OR 97070-1000

# Basic Installation

This chapter describes all of the steps needed to install the TLA 700 Series Logic Analyzer. It is written from the perspective that you purchased most of the items uninstalled and you intend to install all of the pieces. If you purchased a logic analyzer with modules already installed, you should still review all of the information in this chapter and perform those steps that apply to your specific situation.

This chapter deals mainly with hardware installation. The basic operating software is already installed on the internal hard disk. However, if you ordered additional software, such as microprocessor support software, you must install that software yourself. Refer to *Installing Microprocessor Support Software* on page 15.

## Check the Shipping List

Verify that you have received all of the parts of your logic analyzer. Use the shipping lists that came with your logic analyzer to compare against the actual contents of your order. You should also verify the following:

- Verify that you have the correct power cords for your geographical area.
- Verify that you have backup copies of the installed software. Store the backup software in a safe location where you can easily retrieve the software for maintenance purposes.

---

**NOTE.** *Keep the software packaging available because you will need it to enter the Windows 95 software registration number when you first power on the logic analyzer. (See Step 6 under Power on the Logic Analyzer on page 11.)*

---

- Verify that you have the correct module types and probes.
- Verify that you have all the standard and optional accessories that you ordered.

Remember to fill out and send in the customer registration card. The registration card is packaged with this manual.

## Check the Environmental Requirements

Read this section before attempting any installation procedures. This section describes site considerations, power requirements, and ground connections for your logic analyzer.

### Site Considerations: Portable Mainframe

The portable mainframe is designed to operate on a bench or on a cart in the normal position (on the bottom feet). For proper cooling, at least two inches (5.1 cm) of clearance is recommended on the rear and sides of the mainframe.

You can also operate the mainframe while it rests on the rear feet. If you operate the mainframe while it is resting on the rear feet, make sure that you properly route any cables coming out of the rear of the mainframe to avoid damaging them.



**CAUTION.** *Keep the bottom of the mainframe clear of obstructions to ensure proper cooling.*

---

### Site Considerations: Benchtop Mainframe

The benchtop mainframe is designed to operate on a bench or in a rackmount environment. For proper cooling, at least two inches (5.1 cm) of clearance is recommended on the rear and sides of the mainframe.



**WARNING.** *Because of the size and weight of the benchtop mainframe, use care when lifting or moving the mainframe to avoid personal injury while performing the installation procedures. Use two people to lift or move the mainframe.*

---

**Operating Requirements** Table 1 lists the operating requirements for the logic analyzers. Refer to the *TLA 700 Series Logic Analyzer User Manual* for a complete specification list.

**Table 1: Mainframe operating requirements**

Requirement	TLA 704 Color Portable mainframe	TLA 711 Color Benchtop mainframe
Source voltage	90–250 V <sub>RMS</sub> , 45–66 Hz, continuous range 100–132 V <sub>RMS</sub> , 360–440 Hz, continuous range	90–250 V <sub>RMS</sub> , 45–66 Hz, continuous range 100–132 V <sub>RMS</sub> , 360–440 Hz, continuous range
Steady state input current	6 A <sub>RMS</sub> , maximum	15 A <sub>RMS</sub> , maximum at 90 VAC 6.3 A <sub>RMS</sub> , maximum at 207 VAC
Maximum power consumption	600 W	1350 W line power
Temperature (No media in floppy disk drive)	+5° C to +50° C (+41° to +122° F), 15° C/hr (55° F/hr) maximum gradient, noncondensing (derated 1° C (34° F) per 1000 ft (304.8 m) above 5000 ft (1524 m))	+5° C to +50° C (+41° to +122° F), 15° C/hr (55° F/hr) maximum gradient, noncondensing (derated 1° C (34° F) per 1000 ft (304.8 m) above 5000 ft (1524 m))
Humidity (No media in floppy disk drive)	20% to 80% relative humidity, noncondensing. Maximum wet bulb temperature: +29° C (84° F) (derates relative humidity to ~22% @ 50° C (+122° F))	20% to 80% relative humidity, noncondensing. Maximum wet bulb temperature: +29° C (84° F) (derates relative humidity to ~22% @ 50° C (+122° F))
Altitude	To 10,000 ft (3,040 m) (derated 1° C (34° F) per 1000 ft (304.8 m) above 5000 ft (1524 m))	To 10,000 ft (3,040 m) (derated 1° C (34° F) per 1000 ft (304.8 m) above 5000 ft (1524 m))

### Chassis Ground Connections

Figure 1 shows chassis ground connections. Use the chassis ground connections to connect the grounds of one or more instruments to the logic analyzer to ensure a common ground connection between instruments.



---

**WARNING.** Do not remove the safety ground screw from the benchtop mainframe. The safety ground screw must always be in place to ensure the proper bonding of the power supply to the mainframe.

---

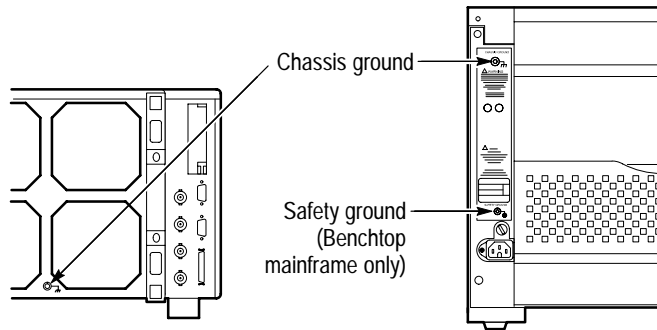

Figure 1: Location of ground connections

## Install the Modules



**CAUTION.** Do not install or remove any modules while the mainframe is powered on; doing so can damage the modules or the logic analyzer.

If your logic analyzer does not have the modules preinstalled, install the modules as shown in Figure 2. You can install the modules in any slot. Use a Phillips screwdriver with a Number 1 tip to tighten the retaining screws after seating the modules in place.

If you want to merge two logic analyzer modules to create a wider module, refer to *Appendix A: Merging Logic Analyzer Modules* on page 33.

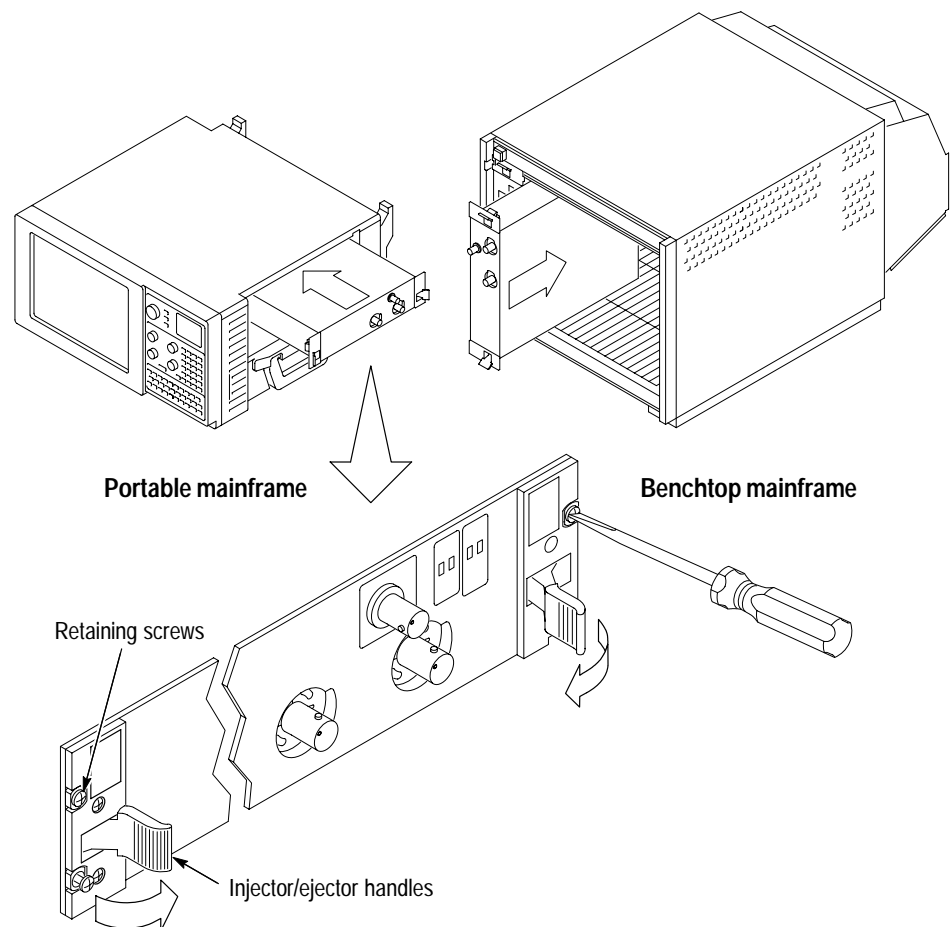

Figure 2: Installing modules

## Cover Empty Slots

If you have any unused (empty) slots in your mainframe, you must install blank slot panel covers to meet EMC specifications. Install a blank slot panel cover for each empty slot as shown in Figure 3. Make sure that the EMI shielding is in contact with the adjacent panel or module cover. Installing the covers provides proper EMI shielding and reduces audible noise.



**CAUTION.** Use only Tektronix TLA 700 Series slot panel covers on the benchtop mainframe. Do not use non-Tektronix covers, otherwise the mainframe may not meet cooling and EMC requirements.

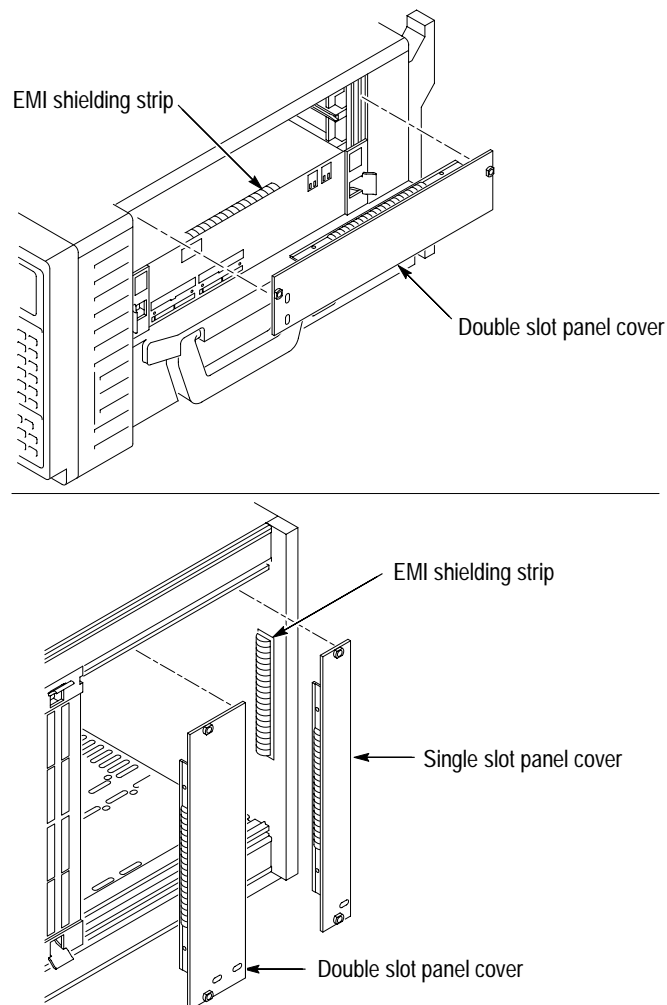

Figure 3: Installing the empty slot panel covers

## Connect the Standard and Other Accessories

The accessory connections are the same as those you would make on a personal computer. The connection points are shown in Figure 4. Use the icons that appear in the circled areas as a guide. See Table 2 on page 8 for additional connection information.

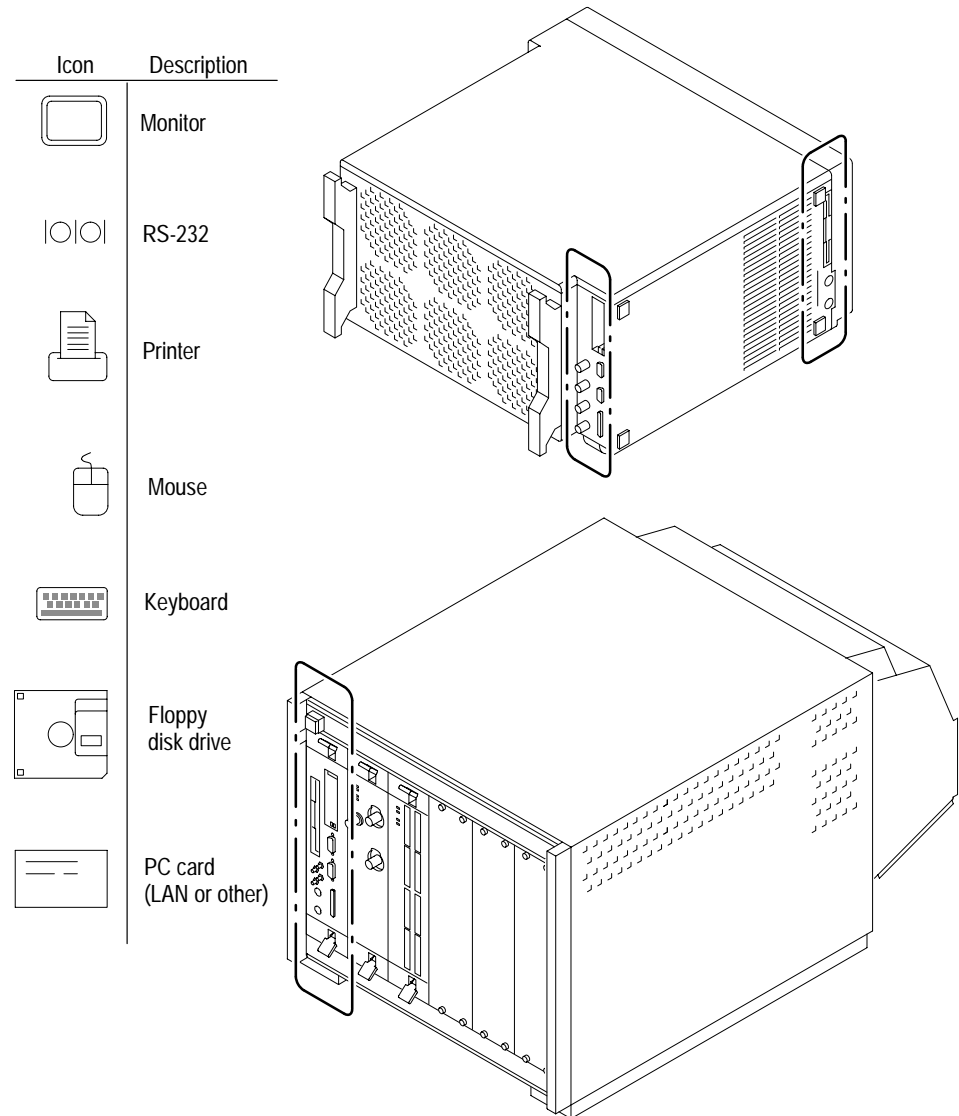

Figure 4: Locations of external connectors



**Table 2: Additional accessory connection information**

Item	Description
Monitor	If you use a non-standard monitor, you may need to change the the Windows 95 display settings to achieve the proper resolution for your monitor. Refer to <i>Set the Display Driver</i> on page 58 or to <i>Adjust the Display Desktop Settings for an External Monitor</i> on page 62. You may also want to refer to the documentation for your display monitor for installation information.
Printer	Connect the printer to the EPP (enhanced parallel port) connector directly. If your printer has a DB-25 connector, use the adapter cable that came with your logic analyzer to connect to the EPP connector.
Rackmount	Refer to the <i>TLA 711 Benchtop Mainframe Rackmount Installation Instructions</i> for information on installing the rackmount kit.
Other	Refer to the TLA 700 Series Application online release notes for additional accessory installation information not covered in this manual. You should also refer to the user or installation documentation that came with your accessory.

## Connect the Probes

Connect the logic analyzer probes and the optional retaining brackets as shown in Figure 5. Then connect the oscilloscope probes.

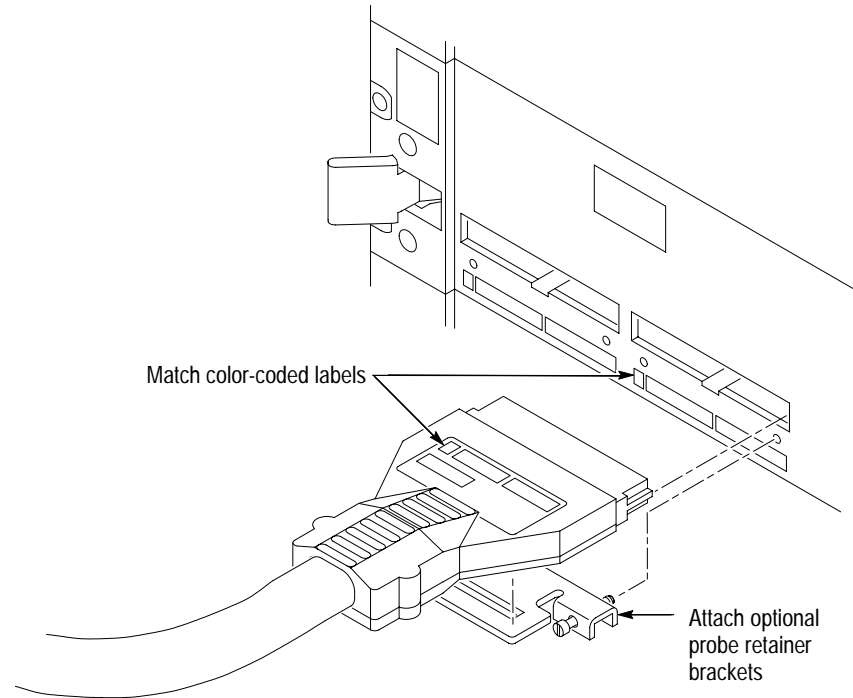

Figure 5: Connecting the logic analyzer probes

## Power On the Logic Analyzer

Follow these steps to power on the logic analyzer for the first time.

1. Check that the line fuse is correct for your application. See Table 3 and Figure 6.

**Table 3: Line fuses**

Line voltage	Rating	Tektronix part number
<b>Portable mainframe</b>		
90 V to 132 V operation	8 A, fast blow, 250 V	159-0046-00
207 V to 250 V operation	6.3 A, fast blow, 250 V	159-0381-00
<b>Benchtop mainframe</b>		
90 V to 132 V operation	20 A, slow blow, 250 V	159-0379-00
103 V to 250 V operation	15 A, fast blow, 250 V	159-0256-00
207 V to 250 V operation	6.3 A, fast blow, 250 V	159-0381-00

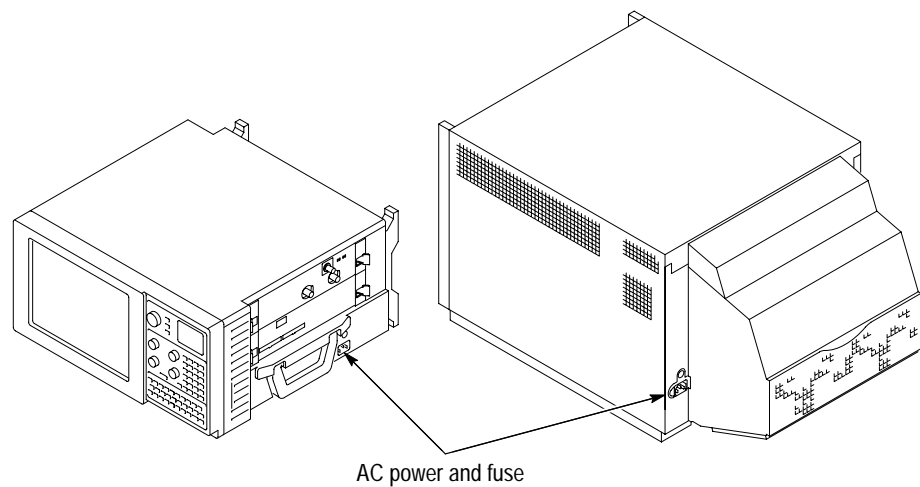

**Figure 6: Line fuse and power cord connector locations**



**CAUTION.** Connect the keyboard, mouse, and other accessories before applying power to the mainframe. Connecting the accessories after powering on the mainframe can damage the accessories. Refer to Figure 4 on page 7 for connection information.

2. Connect the power cord.



**CAUTION.** Although the benchtop mainframe can use the power cord with the 15 A plug, mainframes operating at low line (90 VAC) with four or more instrument modules may require the power cord with the 20 A plug. If you have four or more modules in your mainframe, you must determine the correct fuse and power cord combination to avoid overloading the power distribution system. Refer to Power Cord and Line Fuse Requirements for the Benchtop Mainframe on page 65 for further information.

3. If you have an external monitor, connect the power cord and power on the monitor.
4. Press the On/Standby switch to power on the logic analyzer (see Figure 7 for the switch location).

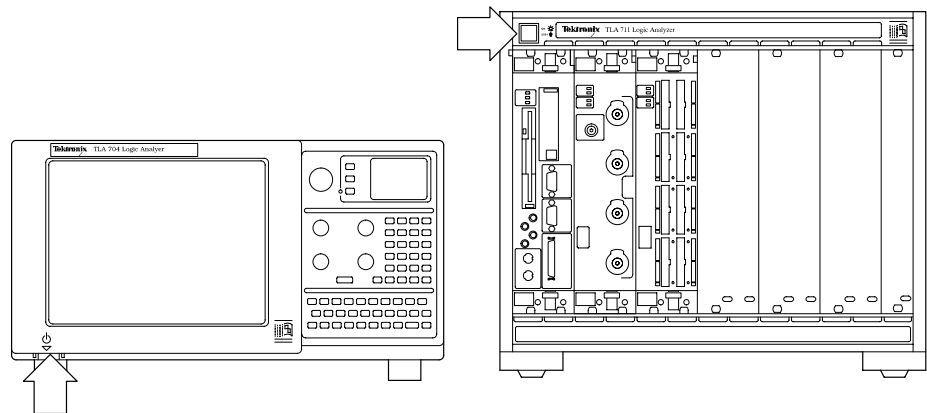

Figure 7: On/Standby switch locations

5. Wait for the boot routine and low-level self test to complete.
6. Follow the instructions on the screen and enter the Windows 95 Product Identification number (located above the bar code) on the Windows 95 software package that came with your logic analyzer. Enter other information as required.

The internal setup software will automatically configure your logic analyzer and install all required devices depending on the installed accessories.

7. Restart your logic analyzer when the setup program is complete.

The next time you power on the mainframe, the logic analyzer application starts automatically.

## Powering Off the Logic Analyzer

The portable mainframe has a built-in soft power-off function that safely powers off the mainframe when you press the On/Standby switch. If you have the benchtop mainframe, you must power off the mainframe using the Windows 95 shutdown process before depressing the On/Standby switch.



---

**CAUTION.** *When powering off the benchtop mainframe, use the Windows 95 shut down procedure. Powering off the benchtop mainframe prematurely can corrupt the software on the hard disk.*

---

## Perform the Incoming Inspection

Incoming inspection consists of verifying the basic operation of the logic analyzer. The Power-on diagnostics check the basic functionality. These diagnostics run every time you power on the logic analyzer.

You can also verify more detailed functionality by running the self calibration and extended diagnostics.

---

**NOTE.** *Allow a 30-minute warm-up before running the self calibration.*

---

Disconnect any attached probes from the modules. Then select the System menu, and point to Calibration and Diagnostics. Run the self calibration followed by the extended diagnostics by selecting the proper tab. Results of the tests display on the individual property page.

---

**NOTE.** *The time required to run the self calibration on the logic analyzer modules depends on the number of acquisition channels. Modules with a large number of channels may take several minutes to run the self calibration.*

---

If you want to perform detailed performance verification procedures, refer to the *TLA 700 Series Performance Verification and Adjustment Technical Reference Manual* (available as an optional accessory).

### Checking the Logic Analyzer Probes (Optional)

Connect the logic analyzer probes to a signal source, start an acquisition, and verify that the acquired data is displayed in either the listing or waveform windows.

**Checking the DSO Probes  
(Optional)**

Connect the oscilloscope probes to the Probe Compensation connector on the front panel of the DSO module. You can then run the Calibrate Probe function in each vertical setup page for the module.

**Checking the Mainframe  
(Optional)**

To check the mainframe diagnostics not covered by the TLA 700 Series Application software. Run the QAPLus diagnostics or the TLA 700 Mainframe Diagnostics located under the Windows 95 Start menu under the Tektronix TLA 700 programs. Exit the TLA 700 Series Application before running the external diagnostics.

## Create an Emergency Startup Disk

Now that you have completed the basic installation process, you should create an emergency startup disk that you can use to restart your logic analyzer in case of a major hardware or software failure. You should create this disk and then store it in a safe place.

The emergency startup disk contains basic files to restart your logic analyzer. It also contains files to check and format the hard disk.

Follow these steps to create the emergency startup disk:

1. Exit the TLA 700 Series application.
2. Click on the Windows 95 Start button, point to Settings, and click Control Panel.
3. In the Control Panel window, double-click Add/Remove Programs.
4. Select the Startup Disk property page.
5. Insert a floppy disk into the disk drive and follow the on-screen instructions to create the startup disk.

## Back Up User Files

You should always back up your user files on a regular basis. Use the Windows 95 Back Up tool to back up files stored on the hard disk. The Back Up tool is located in the System Tools folder in the Accessories folder. Start the tool and determine which files and folders that you want to back up. Use the Windows 95 online help for information on using the Back Up tool.



# Installing Microprocessor Support Software

Each microprocessor support package comes with setup software and required support files. Install the microprocessor software using the setup program on the floppy disk (the following procedure assumes the instrument is already powered on).

---

**NOTE.** *Before you install any software, verify that microprocessor support software is compatible with the logic analyzer software.*

---

1. Insert the floppy disk in the disk drive.
2. Click the Windows 95 Start button, point to Settings, and click Control Panel.
3. In the Control Panel window, double-click Add/Remove Programs.
4. Follow the instructions on the screen for installing the software from the floppy disk.

Similarly, you can remove or uninstall software by following the above instructions and selecting Uninstall.





## The Next Step

Now that you have set up your logic analyzer, you are ready to learn how to use the logic analyzer for various applications. This chapter provides information on other documentation that you may need to operate your logic analyzer.

### Online Help

The online help is the primary source of information for the logic analyzer. The online help provides operational details on the screen without having you refer to printed documentation. Most of the online help information overlaps basic operating information found in the user manual.

The online help also contains basic operating information for microprocessor support products.

An online example is provided to guide you through the basic steps in using your logic analyzer. To access the online help example, start the TLA 700 Series Application, click on Help, Help Topics, and Welcome.

### TLA 700 Series QuickStart Training Board and Manual

The *TLA 7QS Training Manual* is intended to be used with the TLA 700 Series QuickStart Training Board to provide examples of how to use the logic analyzer to solve typical problems. The TLA 700 Series QuickStart Training Board provides a means of connecting the logic analyzer to signal sources for exercises described in the training manual. The training board can be used with the logic analyzer module and the DSO module.

A *TLA 7QS Technical Reference Manual* is also available to provide technical and service information on the TLA 700 Series QuickStart Training Board.

### Other Documentation

Refer to *Related Documentation* in the *Preface* for a list of printed documentation for your TLA 700 Series Logic Analyzer.



# In Case of Problems

This chapter provides information that addresses problems that you may encounter while installing your logic analyzer. This chapter does not identify module-specific problems relating to performance verification or adjustments. For information on running performance verification procedures or adjustment procedures, refer to the instructions in the *TLA 700 Series Performance Verification and Adjustment Technical Reference Manual*, available as an optional accessory to your logic analyzer.

## Diagnostics

The following diagnostic tools are available with your logic analyzer:

- Power on diagnostics. These diagnostics run when you first power on the logic analyzer or when you first start the TLA 700 Series application. If any diagnostic failures occur during power on, the Calibration and Diagnostics property page appears.

---

**NOTE.** Before running the extended diagnostics on the logic analyzer module, disconnect any attached probes.

---

- Extended diagnostics. These diagnostics test the logic analyzer more thoroughly than the power on diagnostics. The TLA 700 Series extended diagnostics test the DSO module as well as the logic analyzer module. You can use the extended diagnostics to isolate problems down to an individual module. The extended diagnostics are part of the TLA 700 Series Application.
- TLA 700 Mainframe diagnostics. The TLA Mainframe diagnostics are a separate Windows 95 application located in the TLA 700 program group. These diagnostics check operation of the mainframe beyond the basic PC circuitry. These diagnostics also check the front panel controls of the portable mainframe.
- QAPLus diagnostics. The QAPLus diagnostics are a separate Windows 95 application located in the Windows 95 Start Programs menu. The diagnostics check the basic operation of the controller including the following items: system board, video, hard and floppy disks, memory, communications port, printer port, mouse and keyboard.

Use the diagnostics to isolate problems to software or hardware within the logic analyzer. For additional help on the diagnostics, contact your local Tektronix representative.

## Software Problems

Your TLA 700 Series Logic Analyzer comes with most software already installed. For any suspected software problems, try to isolate the problem to the TLA 700 Series application software or to other installed software.

Before running any of the diagnostics, you should check the online release notes to verify the logic analyzer software matches the module firmware.

Run the QAPLus diagnostics software to identify hardware or software problems. Follow the QAPLus online help instructions for running the diagnostics software. The diagnostics are located in the Start menu under Programs/ QAPLus\_Win-Win.

Many software problems can be due to corrupted or missing software files. In most cases the easiest way to solve software problems is to reinstall the software and follow the on-screen instructions. Refer to *Upgrading Software* on page 41 for instructions on reinstalling or upgrading software.

Refer to Table 4 on page 21 for a list of software and hardware troubleshooting information and recommended action.

If you suspect problems with the TLA 700 Series software, contact your local Tektronix representative or refer to *Contacting Tektronix* on page xii.

## Hardware Problems

Hardware problems can have several causes. The first step to identifying a problem is to review the installation instructions in this manual to verify that you have properly installed the logic analyzer.

If you are certain that you have installed the logic analyzer correctly, run the TLA 700 Series extended diagnostics (located under the System menu) to identify any problems with the individual modules.

If your logic analyzer powers up so that you have access to the desktop, run the QAPLus diagnostics software to identify possible controller hardware problems. Follow the QAPLus online help instructions for running the diagnostics software. The diagnostics are located in the Start menu under Programs/ QAPLus\_Win-Win.

You can also run the external TLA 700 Mainframe diagnostics to identify problems not covered by other diagnostics. The TLA 700 Mainframe diagnostics are located under the Start menu under the Tektronix TLA 700 programs.

Table 4 lists some of the symptoms of hardware problems and possible solutions.



**CAUTION.** Do not attempt to remove or reinstall modules in the logic analyzer while the logic analyzer is receiving power. Power off the logic analyzer and disconnect the power cord before removing and installing modules. Failure to do so can damage the logic analyzer or the individual modules.

Table 4: Troubleshooting

Symptom	Possible causes and recommended action
Mainframe does not power on	<p>Verify that all power cords are connected to the mainframe and to the power source.</p> <p>Check that the mainframe receives power when you press the On/Standby switch; check that fans start and that front-panel indicators light.</p> <p>Check that power is available at the power source.</p> <p>Check for failed fuses (see Table 3 on page 10 for mainframe fuse information).</p> <p>Mainframe failure; contact your local Tektronix service center.</p>
Monitor does not power on	<p>Check the monitor power cord connection.</p> <p>Check for failed fuse.</p> <p>Monitor failure; contact the vendor of your monitor for corrective action.</p>
Monitor display is blank	<p>Check that the monitor is connected to the mainframe; replace the cable if necessary.</p> <p>If portable mainframe display is blank, try connecting external monitor; if both displays are blank, contact your local Tektronix service center.</p> <p>External monitor controls turned down; adjust monitor controls for brightness and contrast.</p> <p>Check the controller BIOS setups for the monitor.</p> <p>Faulty monitor; contact the vendor of your monitor for corrective action.</p>
Mainframe powers on but does not complete the power-on sequence	<p>Power off mainframe and check that all modules are fully inserted.</p> <p>If mainframe is a benchtop mainframe, check the status of the SYSTEM FAIL and TEST LEDs on the benchtop controller. If either LED stays on, contact your local Tektronix service center.</p> <p>Check the status of the READY and ACCESSED LEDs on the front panel of the application modules. The READY LED turns on when the module passes the power on diagnostics and when the module is ready to communicate with the controller. The ACCESSED LED turns on any time the controller accesses the module.</p> <p>Check for disk in floppy disk drive; make sure mainframe boots from the hard disk drive.</p> <p>Check for faulty module. Remove modules one at a time and power on the mainframe. If mainframe completes the power-on sequence, replace faulty module.</p> <p>Possible software failure or corrupted hard disk; see <i>Software Problems</i> at the beginning of this chapter.</p>
Power-on diagnostics fail	<p>Isolate problem to faulty mainframe or to faulty module. Multiple diagnostic failures across modules indicate a faulty mainframe. Diagnostic failures confined to an single module most likely indicate a faulty module. Contact your local Tektronix service center.</p>

**Table 4: Troubleshooting (Cont.)**

Symptom	Possible causes and recommended action
Mainframe does not recognize accessories such as monitor, printer, or keyboard	Check that accessories are properly connected or installed. Try connecting other standard PC accessories or contact your local Tektronix service center.
LA Module merge not recognized	Modules not merged; check merge connection. Faulty module; replace with known-good module or contact your local Tektronix service center.
Windows 95 comes up but the TLA 700 application does not	Mainframe not set up to start TLA 700 application at power on. Start application from the desktop, by double-clicking on the TLA 700 icon; see the TLA 700 application online help on <i>Powering On and Off</i> for setting the startup sequence. Faulty or corrupt software; reinstall the TLA 700 application software.
Windows 95 comes up in Safe mode	Exit the Safe mode and restart the mainframe. Incompatible hardware and hardware driver software. Either install hardware driver or remove the incompatible hardware.
TLA 700 application starts but modules do not display in System window	Power off mainframe and check that all modules are fully inserted. Flash programming jumper installed. Power off mainframe and remove module. Remove jumper (see Figure 21 on page 50), and reinstall module. Module address switches not set correctly. Power off mainframe and remove module. Set address switches to FF and reinstall module (refer to Figure 21 on page 50 for address switch locations). Module failure; replace with known-good module or contact your local Tektronix service center. Mainframe failure; contact your local Tektronix service center.
Portable Mainframe will not power off with On/Standby switch	The Mainframe Utilities may be set up to disable hard power off. Check the setting of the Mainframe Utilities (the Mainframe Utilities are located in the Windows 95 Control Panel). The Windows 95 operating system problem. Try powering off the mainframe using the Windows 95 shutdown procedure. If the mainframe still does not power off, disconnect power cord and reconnect after 10 seconds to reboot the mainframe.

## TLA 700 Startup Sequence

The following information is intended to provide troubleshooting hints in case the logic analyzer fails to complete the startup sequence. You may want to refer to Figure 8 on page 24 while reading the following paragraphs.

At power on, the logic analyzer starts the mainframe and module kernel tests. If the mainframe passes the kernel tests, it begins to boot the Windows 95 operating system. If the mainframe fails the kernel tests, it displays the error codes, beeps, and terminates the startup sequence.

The Windows 95 operating system starts the resource manager. The resource manager performs the following tasks:

- Starts the mainframe power-on self tests
- Verifies the power-on self test status
- Inhibits any failed modules
- Records the power-on self test failures
- Determines the logic analyzer configuration
- Executes the system controller power-on diagnostics

After completing all of the above tasks, the logic analyzer starts the TLA 700 application. The TLA 700 application performs the following tasks:

- Performs the power-on diagnostics on all installed modules
- Performs the power-on diagnostics on the TLA 700 system
- Records the Pass/Fail status in the Calibration and Diagnostics property sheet

If no failures occur, the TLA 700 application is ready to use for regular tasks.



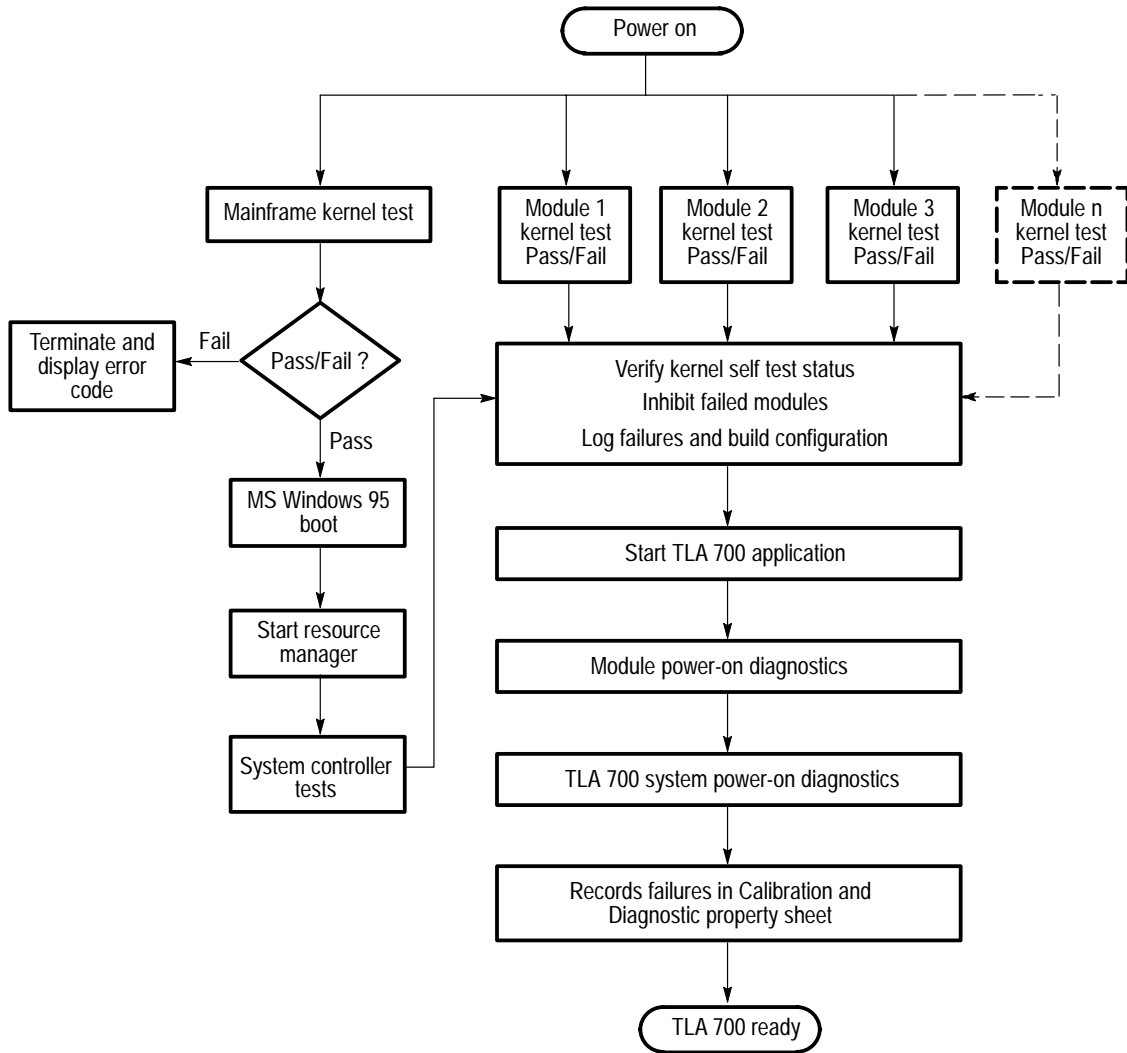

Figure 8: TLA 700 startup sequence

## Replacing Podlets on the P6417 Logic Analyzer Probe

Although your logic analyzer was fully tested at the factory prior to shipment, there may be reasons to move or replace podlets on your logic analyzer probes.

### Moving Probe Podlets

Depending on your application, you can move or reposition probe podlets as shown in Figure 9. When moving podlets in the podlet holder keep the ground side of the podlets together.

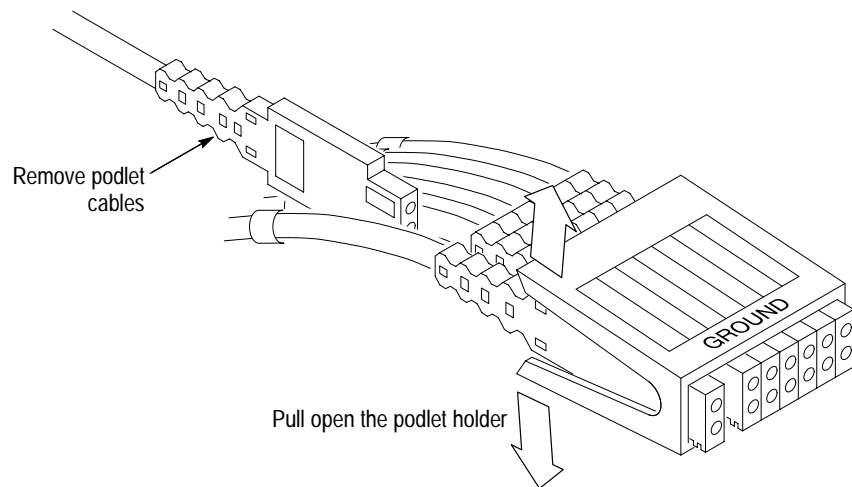

Figure 9: Moving probe podlets

## Replacing Probe Podlets

The podlet replacement procedure consists of identifying the faulty podlet and replacing it with a new one. A podlet replacement kit is available as an optional accessory.

---

**NOTE.** Refer to the TLA 700 Online Help for part numbers of the TLA 700 accessories.

---

**Equipment and Required Material.** You will need the following equipment and material:

- Replacement podlet
- Masking tape
- Small diagonal cutters
- Screwdriver with #1 Phillips tip

**Replacement Procedure.** Perform the following steps to replace a faulty probe podlet:

1. Identify and mark the faulty podlet.
2. Disconnect the probe from the logic analyzer and set the probe cable on a clean working surface.

---

**NOTE.** If you need to replace more than one podlet, replace the podlets one at a time to avoid mixing them up.

---

- Using the screwdriver with the #1 Phillips tip, remove the four screws on the probe housing on the module end of probe cable (see Figure 10).

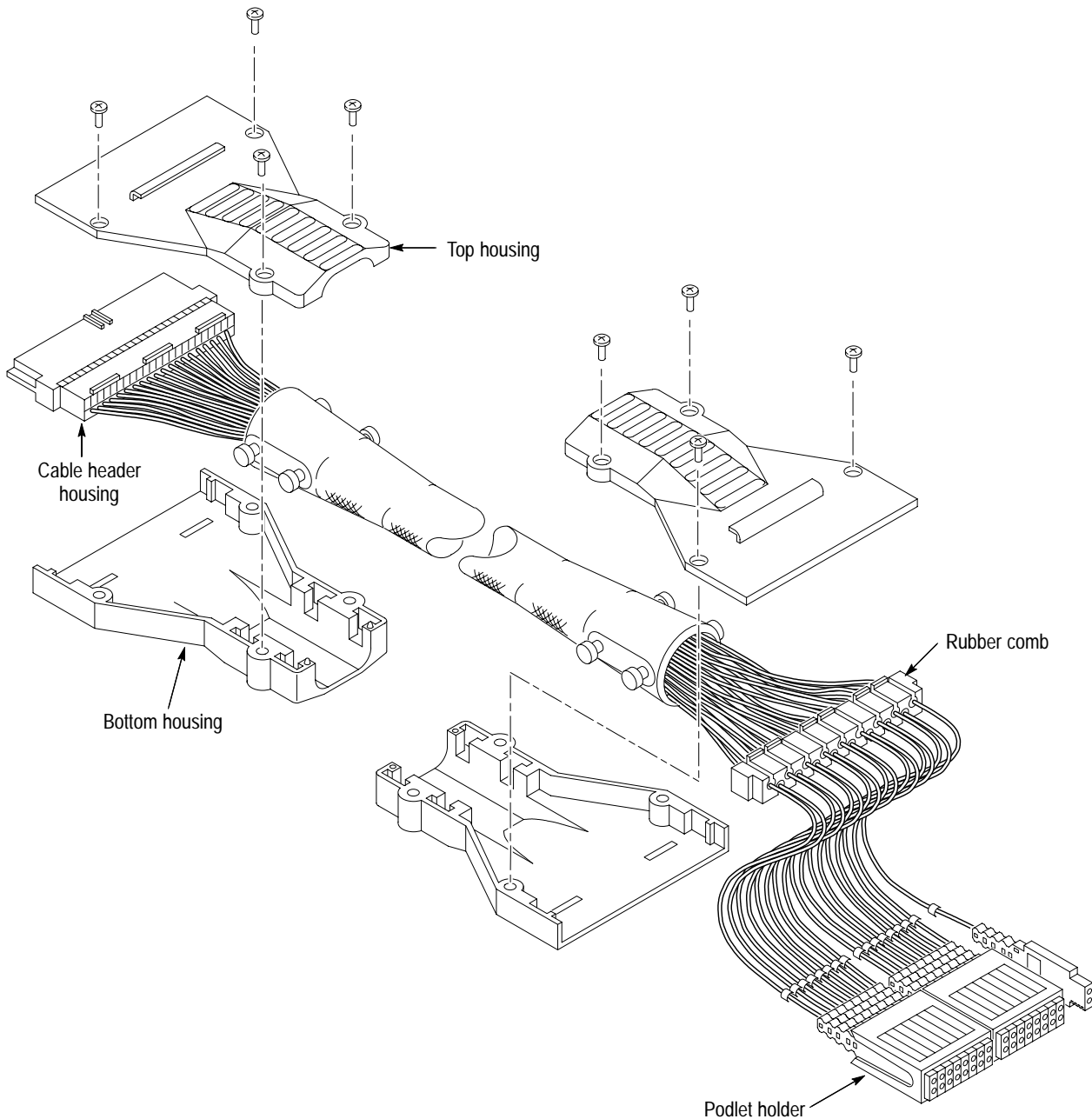
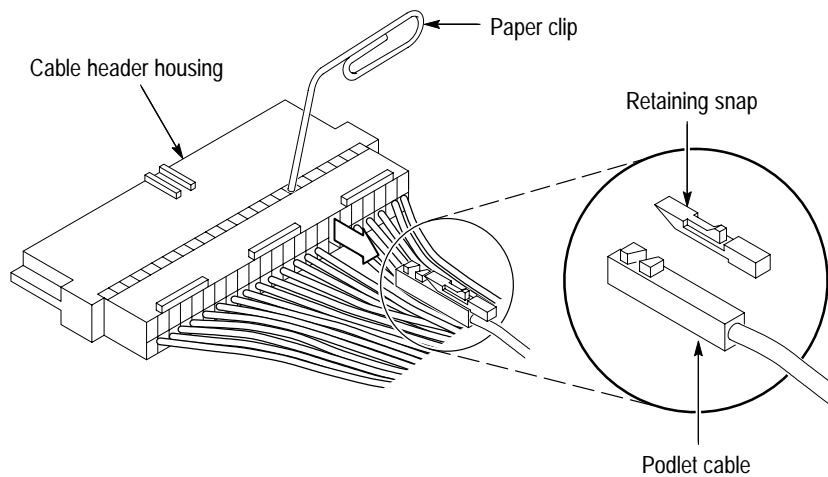

Figure 10: Disassembling the probe cable

- Remove the top and bottom probe housings and set them aside.

5. Remove the remaining top and bottom probe housings and set them aside. Do not mix the probe connector-end housings with the podlet connector housings; the labels are different at each end of the probe.
6. Identify the faulty probe channel at the module end of the cable.
7. Refer to Figure 11 and use a small pointed tool, such as a straightened paper clip or a mechanical pencil, to release the faulty cable from the cable header housing. Discard the small plastic retaining snap.



**Figure 11: Removing the faulty channel from the probe cable header housing**

8. Identify the faulty probe channel at the podlet end of the probe.



---

**CAUTION.** Be sure that you have identified the correct podlet cable before you cut the cable.

---

9. Cut the faulty podlet just above the color-coded ring.
10. Remove the color-coded ring and set it aside; you will need to install it on the replacement cable later in this procedure.

11. Refer to Figure 12 and bend the rubber comb to remove the faulty podlet cable from the comb.

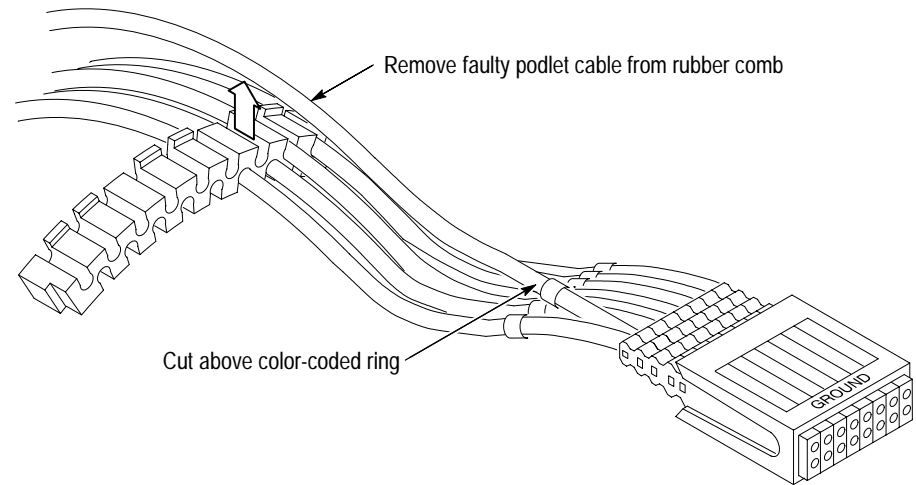

**Figure 12: Removing a podlet cable from the rubber comb**

12. Attach the module end of the replacement podlet cable to the cut end of the faulty podlet cable in the following manner:
  - a. Lay the two cables in parallel with a four-inch (10 cm) to six-inch (15 cm) overlap.
  - b. Wrap the overlapping portion of the two podlet cables tightly with masking tape to temporarily splice them together.
13. Pull the faulty cable from the module end through the mesh sleeve so that the replacement cable is drawn through the mesh sleeve. Stop pulling when the replacement cable is located at the proper position in the cable wire bundle.

14. Remove the faulty podlet cable from the podlet holder and replace it with the new cable as shown in Figure 13.

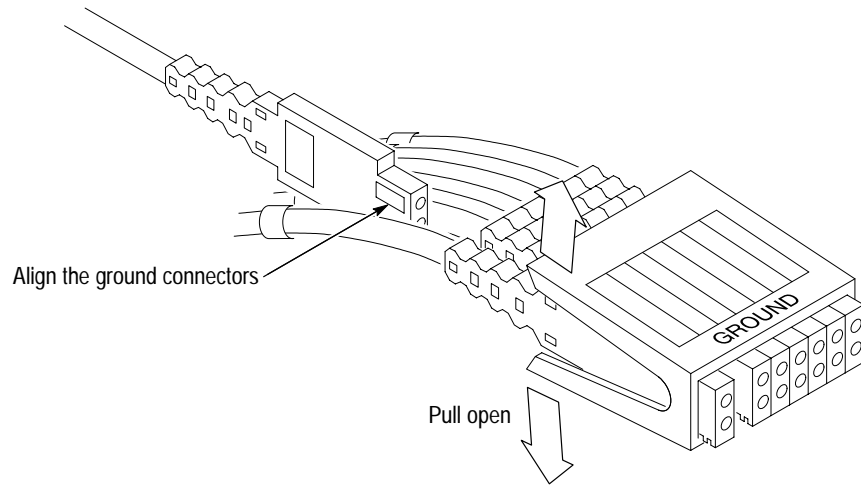

**Figure 13: Replacing a podlet in the podlet holder**

15. Take the color-coded ring that you removed in step 10 on page 28 and slide it onto the installation tool. (The installation tool is included in the podlet replacement kit.)



---

**CAUTION.** Do not damage the cable with the installation tool when installing the color-coded ring.

---

16. Refer to Figure 14 and place the installation tool over the replacement podlet cable as shown. Slide the color-coded ring down the installation tool onto the replacement cable. Position the ring so that it is in the same relative position as the other color-coded rings (approximately 0.5-inch from the podlet).

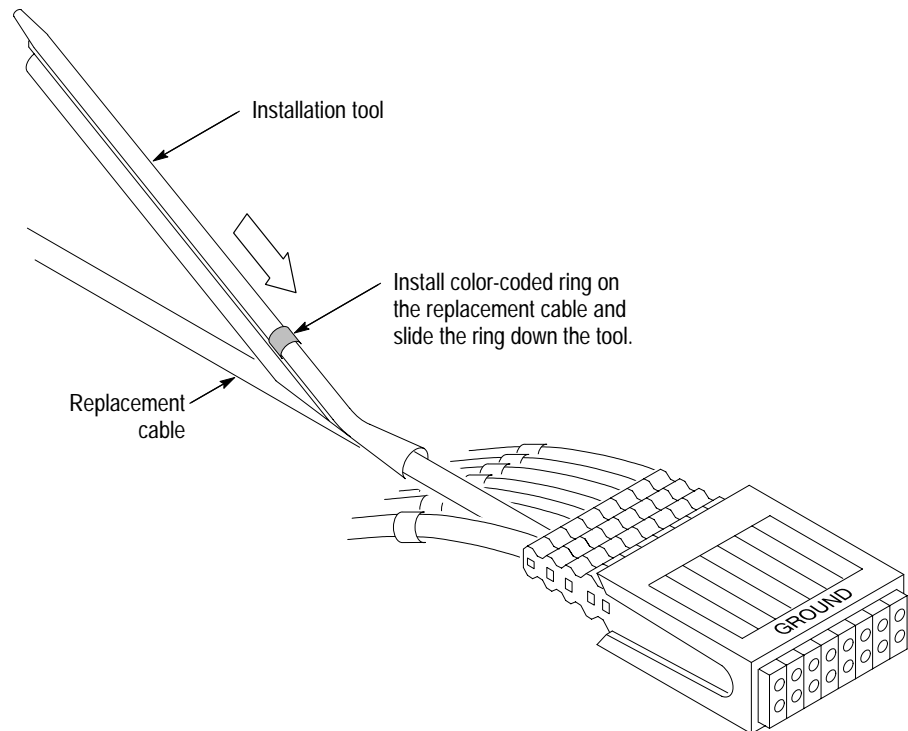
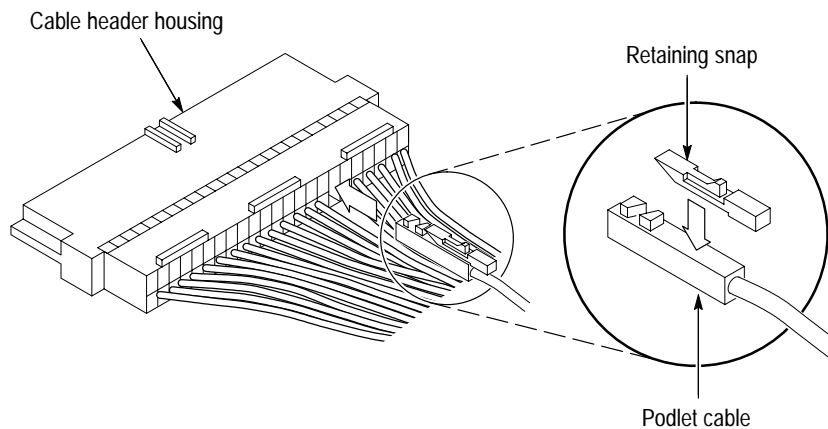

**Figure 14: Installing the color-coded ring**

- 17.** Push the new podlet cable into the rubber comb.
- 18.** Unwrap and remove the masking tape from the splice of the two cables and discard the faulty cable.
- 19.** Remove the protective 1x2 housing from the new podlet cable. Use the same procedure as in Step 7 on page 28 to remove the plastic retaining snap. Discard the retaining snap and the protective housing.



20. Insert the new podlet cable partially into the cable header housing. Place a new retaining snap (included with the kit) on the podlet cable as shown in Figure 15 and fully insert the cable and retaining snap into the cable header housing. Tug lightly on the podlet cable to ensure the retaining snap is in place.



**Figure 15: Installing the cable in the cable header housing**

21. Reinstall the top and bottom probe housings on the module end of the probe cable in the following manner (refer to Figure 10 on page 27 if necessary):
  - a. Line up the two tabs on the probe header with the two embedded slots in the bottom (deep) probe housing.

---

**NOTE.** *It may be necessary to push or pull the cables in the sleeve so that the probe header lines up properly with the slots in the bottom probe housing.*

---

- b. Place the two metallic guides on the probe sleeve in the slots in the bottom probe housing.
    - c. Line up the three tabs of the probe header with the three embedded slots in the top probe housing.
    - d. Install and tighten the four screws in the probe housing.
    - e. Smooth the sleeve by hand to ensure the sleeve fully covers the cables when replacing the probe housing over the comb.
22. Repeat step 21 to install the probe housing over the rubber comb on the podlet end of the probe cable.

# Appendix A: Merging Logic Analyzer Modules

This appendix describes how to merge two logic analyzer modules to form a wider module.

There are no specific rules to merging modules. However, the following guidelines may be helpful.

- You can merge modules with 102 channels or greater.
- The maximum merged module width is two modules.
- The two modules should have the same firmware version.
- The two modules should have the same state speed.
- When merging modules of unequal channel widths, place the module with the higher number of channels in the lower numbered slot.
- Merged modules of unequal memory depths will assume the depth of the shallower module.

## Equipment Required

You will need the following equipment to complete these procedures:

- Torque screwdriver with a size T-10 Torx tip
- Two logic analyzer modules

## Merge Procedure



---

**CAUTION.** *Static discharge can damage any semiconductor component in the logic analyzer module. Discharge the static voltage from your body by wearing a grounded antistatic wrist strap while performing the Merge Procedure.*

---

Perform the following steps to merge two logic analyzer modules:

1. Power off the logic analyzer and remove the modules.
2. Determine which module will be designated as the slave module (this module will be placed in the higher numbered slot).
3. Lay the slave module on the right side (as viewed from the front panel).

4. Use the screwdriver with the T-10 Torx tip and remove the eight screws from the cover (Six screws on the cover, and two screws on the rear panel, see Figure 16).
5. Remove the four flat-head screws near the front of the module (102-channel modules only have two flat-head screws).
6. Remove the two screws holding the Merge cable bracket to the cover.
7. Remove the top part of the cable bracket and set it aside.
8. Remove the cover and locate the Merge cable.

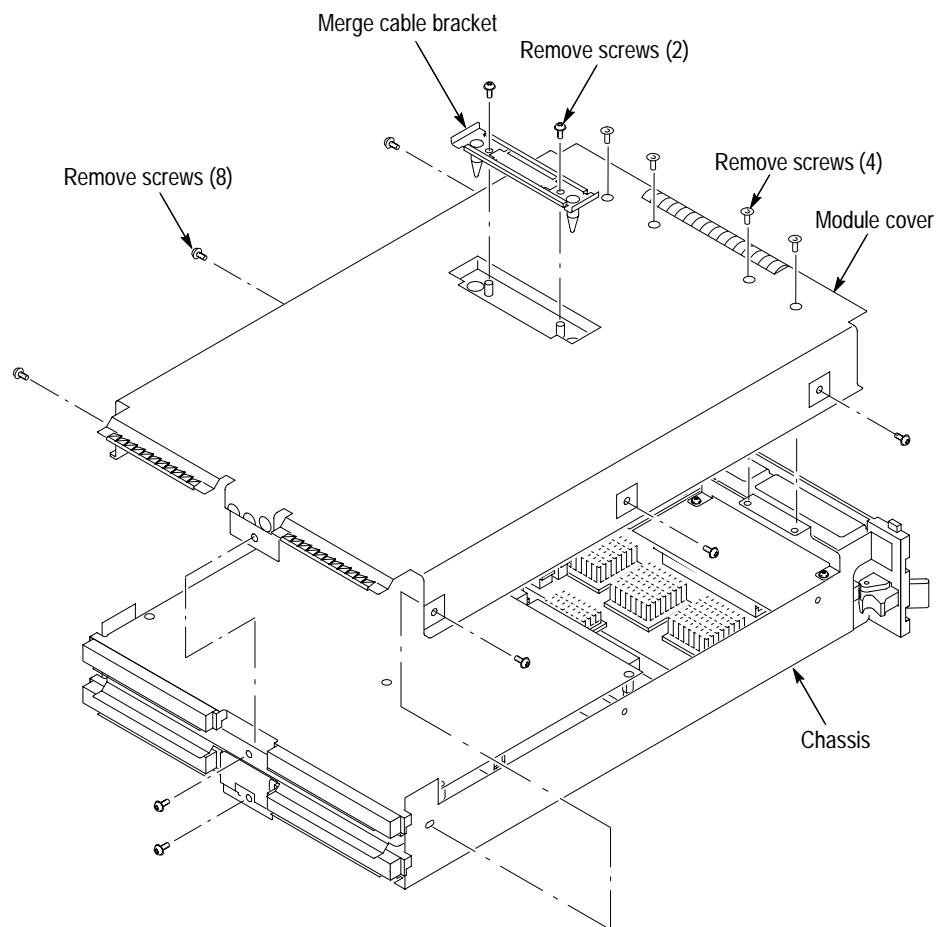

Figure 16: Removing the cover

9. Replace the cover while feeding the Merge cable through the hole in the cover (see Figure 17). Do not twist the cable while feeding it through the hole, otherwise the cable will not connect properly to the adjacent module.

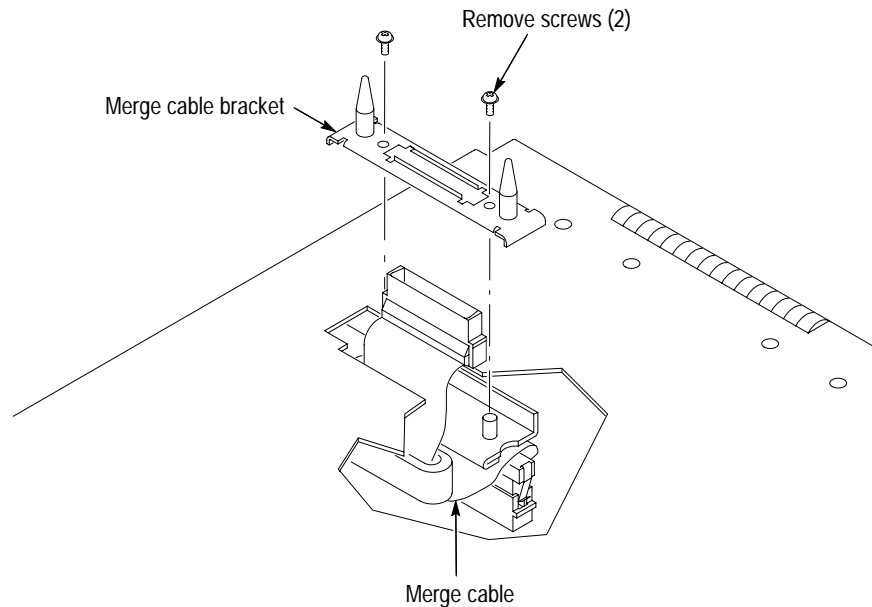

Figure 17: Feeding the Merge cable through the cover

10. Turn the Merge cable bracket over so that the guide pins point up and place the bracket over the Merge cable connector.
11. Install the two screws that hold the Merge cable bracket in place.



**CAUTION.** To prevent damage to the module during the installation process, reinstall the cover exactly as described in steps 12 through 16. If the cover is not properly seated, the module can be damaged when you install it in the logic analyzer or it will not meet EMC requirements.

12. Push forward on the cover so the tab on the front edge of the cover inserts into the rear of the front subpanel. Make sure that the cover is fully seated (no gaps) against the front and rear chassis flanges (see Figure 18).

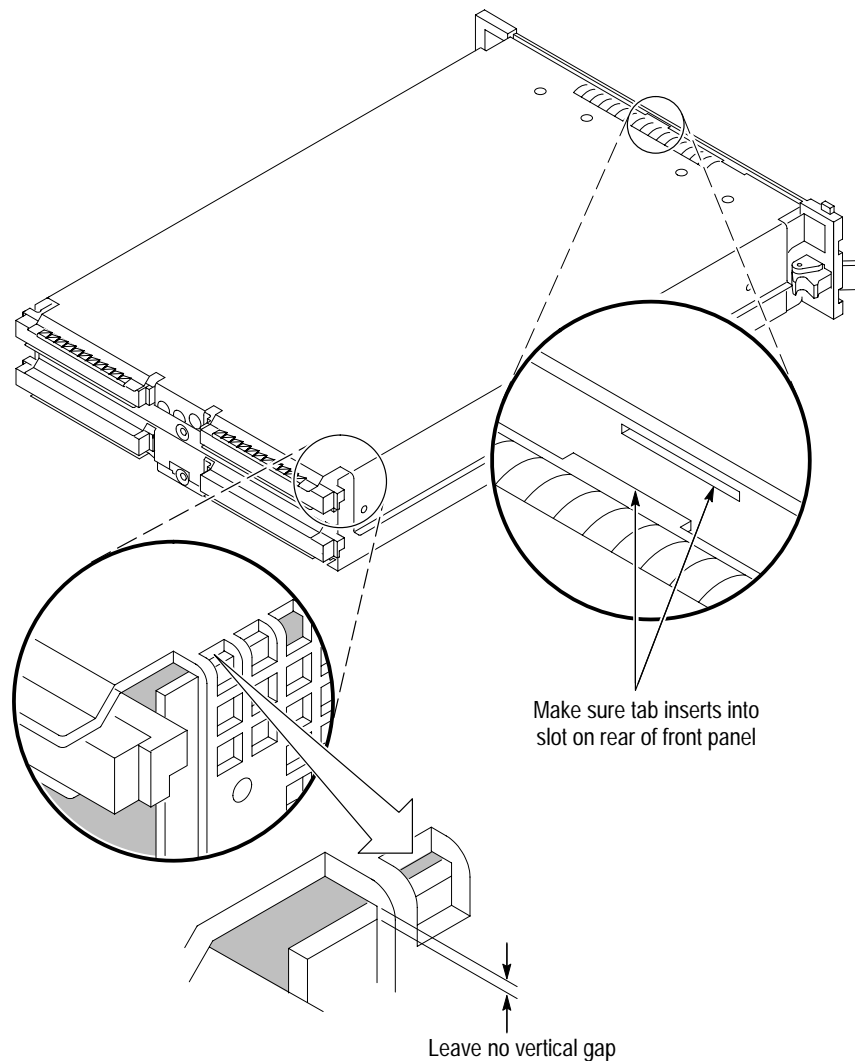

**Figure 18: Seating the cover on the chassis**

13. While holding the cover in place, install the four screws nearest the front of the module (two on the top and two on the bottom), to secure the cover to the chassis.
14. Install the flat-head screws near the front of the module.
15. Slide the rear panel on the chassis and install the two rear panel screws.
16. Install the top and bottom rear screws.

17. Check and tighten all screws to 4 in lbs.

18. Place the Master module adjacent to the Slave module so that the two guide pins from the Slave module line up with the guide pin holes in the Master module (see Figure 19).

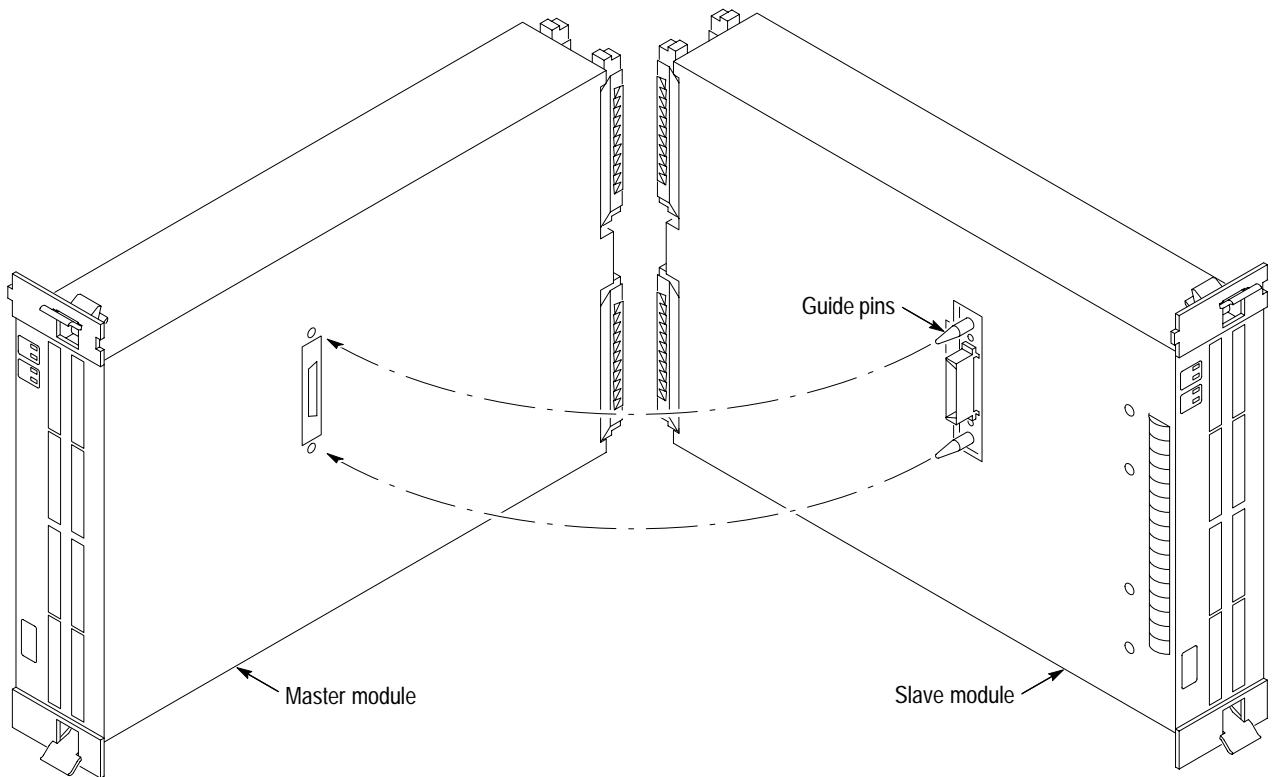

Figure 19: Lining up the two modules

19. Gently push the two modules together so that the Merge cable of the Slave module mates with the Merge cable connector on the Master module.

## Installing the Merged Modules in the Logic Analyzer

After merging the two modules, perform the following steps to install the module pair in the logic analyzer:

1. Hold the module pair such that the two modules do not become separated and line up the modules with the slot guides in the logic analyzer.
2. Push both of the modules in the logic analyzer until they rest against the rear panel connector. Use the injector/ejector handles to fully seat the modules one at a time. Tighten the module retainer screws.

3. Verify that the modules are fully seated before powering on the logic analyzer.
4. After powering on the logic analyzer, run the merge calibration to calibrate the module pair (select the system menu, point to Calibration and Diagnostics, point to the Self Calibration property page, and select the merged pair in the list box).

## Removing Merged Modules from the Logic Analyzer

Perform the following steps to remove merged modules from the logic analyzer:

1. Identify the two logic analyzer modules that you want to remove.
2. Loosen the retainer screws for both modules (top and bottom).

---

**NOTE.** Use the ejector handles to just loosen the modules from the rear panel connector before sliding both modules out of the logic analyzer.

---

3. Use the ejector handles to disconnect the first module from the rear panel connector.
4. Use the ejector handles to disconnect the second module from the rear panel connector.
5. Slide both modules out of the logic analyzer at the same time.
6. Gently pry the two modules apart.

## Storing the Merge Cable

Perform the following steps to store the Merge cable inside the logic analyzer module:

1. Use the screwdriver with the T-10 Torx tip to remove the two screws that hold the Merge cable bracket in place.
2. Remove the Merge cable bracket.
3. Use the screwdriver with the T-10 Torx tip to remove the screws from the side cover and rear cover (see Figure 16 on page 34).
4. Push the Merge cable through the side cover and remove the cover.
5. Dress the Merge cable as shown in Figure 20.

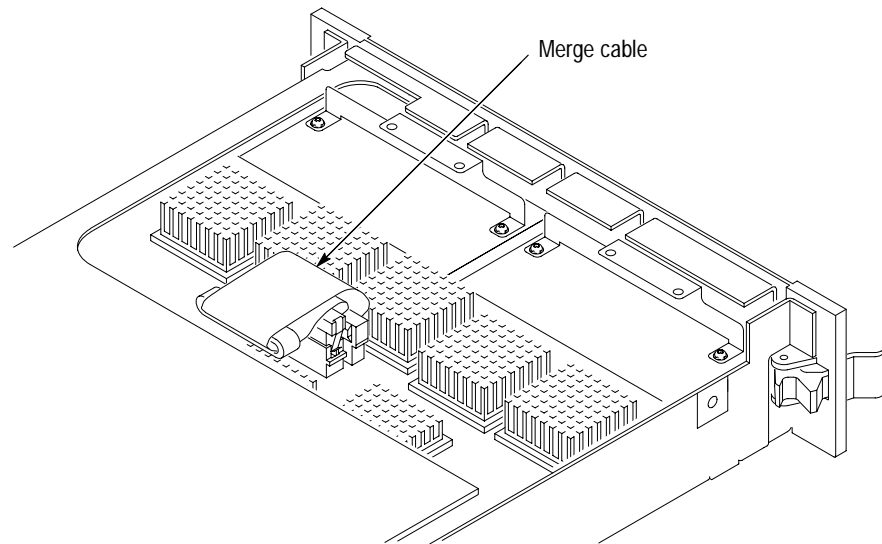

**Figure 20: Dressing the Merge cable before installing the cover**



**CAUTION.** To prevent damage to the module during the installation process, reinstall the cover exactly as described in steps 6 through 8. If the cover is not properly seated, the module can be damaged when you install it in a mainframe or it will not meet EMC requirements.

6. Push forward on the cover so the tab on the front edge of the cover inserts into the rear of the front subpanel. Make sure that the cover is fully seated (no gaps) against the front and rear chassis flanges (see Figure 18 on page 36).
7. While holding the cover in place, install the four screws nearest the front of the module (two on the top and two on the bottom), to secure the cover to the chassis.
8. Install the flat-head screws near the front of the module.
9. Slide the rear panel on the chassis and install the two rear panel screws.
10. Install the top and bottom rear screws.
11. Install the Merge cable bracket so that the guide pins point into the module.
12. Install and tighten the two screws on the Merge cable bracket.
13. Verify that you have installed and tightened all screws to 4 in lbs on the module.





# Appendix B: Upgrades

This appendix describes procedures for upgrading your logic analyzer software or firmware. The following sections are included:

- Restoring or upgrading software in your logic analyzer
- Installing TPI, the TLA 700 Programmatic Interface (page 43)
- Restoring or upgrading firmware in your logic analyzer module or DSO module (page 50)
- Restoring or changing the Controller BIOS setup (page 52)
- Reinstalling Software (page 56)
- Customizing the TLA 700 Series setups (page 61)

## Upgrading Software

This section provides information for restoring or upgrading software in your logic analyzer. In addition to the TLA 700 software, there are other software programs that are installed separately; Table 5 lists some of the software and installation information.

**Table 5: Software not covered by the TLA 700 Series software setup**

Software	Installation information
Microsoft Windows 95 OS <sup>1</sup>	Refer to the Windows 95 documentation or contact your local Microsoft representative.
QAPlus Diagnostic Software	Refer to the QAPlus online documentation or to <i>Reinstall the QAPlus Diagnostic Software</i> on page 59.
Logic Analyzer Module & DSO Module Performance Verification and Adjustment	Refer to the <i>TLA 700 Series Performance Verification and Adjustment Technical Reference Manual</i> for instructions on installing and using the PV/Adjust software.
Microprocessor Support Software	Refer to <i>Installing Microprocessor Support Software</i> beginning on page 15 in this manual.
PC Card Software	Refer to the instructions that come with your PC Card.
Other software	Refer to the instructions that come with your software.

<sup>1</sup> For information on installing Microsoft Windows 95 software not available on the Windows 95 backup floppy disks, refer to the MS Web Site at <http://www.microsoft.com/windows/software/cdextras.htm>

### Upgrading or Reinstalling TLA 700 Software

You can update or reinstall the TLA 700 software by executing the setup.exe program on the Disk #1 of installation disks or by performing the following steps.

---

**NOTE.** *The following instructions assume that you are reinstalling the TLA 700 application software only. If you are installing the software on a new hard disk drive, refer to the instructions under Reinstalling Software on page 56.*

---

1. If the TLA 700 application is running, exit the application before continuing.
2. Insert the TLA 700 application floppy disk 1 in the disk drive.
3. Click Start, point to Settings, and click Control Panel.
4. In the Control Panel window, double-click Add/Remove Programs.
5. Click on the Install button and follow the instructions on the screen for installing the software from the floppy disk.

If the setup program finds an earlier version of the TLA 700 Application, the program will ask you to confirm your selection and then will remove the software. At the end of the removal process, the program will ask you to remove the floppy disk and then restart the logic analyzer to complete the file removal process.

6. After the logic analyzer restarts, reinsert the floppy disk and repeat steps 1 through 5 to install the application software.

When executed, the setup program will replace old versions of the software after you have confirmed your choice. The program also offers to delete shared files which appear to be no longer needed by any application.

The program will not remove saved TLA files or microprocessor support packages.

### Uninstalling TLA 700 Software

You can also remove or uninstall the TLA 700 software using the Uninstall program. Use the Add/Remove Programs tool under the Control Panel to uninstall software.

---

**NOTE.** *The TLA 700 Software Setup program automatically invokes the Uninstall program before reinstalling the TLA 700 software.*

---

## Installing TPI

Use these procedures to install the TLA 700 Programmatic Interface (TPI). In these procedures, client refers to the user written application that controls the logic analyzer through the TPI. Server refers to the TLA 700 application software. For additional information on installation, refer to the online help.

You have two methods of using TPI with your client application:

- You can run the client application locally on the logic analyzer. No special setup is required. To verify that a client application can connect to the TLA 700 server, see *Running a Client Application on the Logic Analyzer*.
- You can run your client application remotely across the network. In this case, both the logic analyzer and the remote host require special setup procedures. See *Setting Up TPI for Remote Access on the Logic Analyzer* to begin this setup procedure.

In the following procedures, **<install directory>** refers to the directory where the TPI client is installed on your client machine. This directory is **C:\Program Files\TLA 700** by default.

If you need to use the type library (tla700.tlb), this file will be located in **C:\Program Files\TLA 700\System\TPI** on the logic analyzer and/or in the **<install directory>\System\TPI** on your client machine.

### Running a Client Application on the Logic Analyzer

To verify that a client application on the logic analyzer can connect to the TLA 700 application, do the following steps:

1. Start the TLA 700 application on the logic analyzer.
2. Navigate to and run the following program: **C:\Program Files\TLA 700\Samples\TPI Samples\VC++\test client\testclient.exe**
3. The Tektronix Test TPI Client dialog appears. Click the Connect to TLA 700! button.
4. Check that the text in the dialog changes to Connected! This indicates the test client application connected to the logic analyzer. Click Exit.

The client application will run locally on the logic analyzer. For remote operation, see *Setting Up TPI for Remote Access on the Logic Analyzer*.

### Setting Up TPI for Remote Access on the Logic Analyzer

If you want to run a client application remotely across the network, you must set up the logic analyzer using the following procedure:

1. Install and configure TCP/IP. (networking)

---

**NOTE.** *If you have difficulty configuring the network setup, contact your system administrator.*

---

2. Download the following from Microsoft's web site. Microsoft's web site is: <http://www.microsoft.com/com/dcom95/download-f.htm>

- Distributed COM for Microsoft Windows 95 (DCOM95)
- DCOM for Microsoft Windows 95 configuration utility (only required for user level access)

Install the downloaded files and restart the TLA 700 after each installation. For more information on DCOM, refer to the Microsoft website.

3. You can choose to have share-level or user-level access to the logic analyzer as provided by Microsoft Windows 95.

Share-level access allows a password to be assigned to each shared resource. For Microsoft Windows 95-only networks, share-level access is the only option.

User-level access allows a group of users to have access to each shared resource.

---

**NOTE.** *For TPI to work with share-level access, authentication is turned off and any COM client can call into any COM server running on the logic analyzer.*

---

**Setting the Access Level on the Logic Analyzer.** To set up the access level on the logic analyzer, do the following steps:

1. Click Start, point to Settings, and select Control Panel.
2. From the Control Panel, select Network, then click the Access Control tab.
3. To select share-level access, choose Share-level access control, and then click OK.

To select user-level access, choose User-level access control and enter the name of the domain that will be used to validate user access. Click OK.

4. Click Start again, and then Shut Down. In the Shut Down Windows dialog box, select Restart the Computer? and then click the Yes button.
5. If you are setting up share level access, navigate to and double-click **C:\Program Files\TLA 700\System\TPI\Share Level Access Server.reg**

If you are setting up user level access, navigate to and double-click **C:\Program Files\TLA 700\System\TPI\User Level Access Server.reg**

6. A dialog appears, indicating successful registration. Click OK.

7. Restart the logic analyzer, using the procedure in step 4.
8. Start the TLA 700 application on the logic analyzer if it is not already running.

This completes the setup of TPI on the logic analyzer for operating with a remote client machine.

Next, you need to set up the client machine so that it can connect to the logic analyzer. Refer to the appropriate setup:

- *Setting Up a Client Machine that is Running Microsoft Windows 95* on page 45.
- *Setting Up a Client Machine that is Running Microsoft Windows NT* on page 48.
- *Setting Up a Client Machine Running on Any Other Platform* on page 49.

### Setting Up a Client Machine that is Running Microsoft Windows 95

After you set up the logic analyzer, you must set up the client machine using the following procedure:

1. Install and configure TCP/IP. (networking)
2. Load the Tektronix TPI Client Install diskettes supplied with the TLA 700 instrument.
3. Double-click on **Setup.exe**.
4. Download the following from Microsoft's web site. Microsoft's web site is: <http://www.microsoft.com/com/dcom95/download-f.htm>
  - Distributed COM for Microsoft Windows 95 (DCOM95)
  - DCOM for Microsoft Windows 95 configuration utility (only required for user level access)

Install the downloaded files and restart the TLA 700 after each installation. For more information on DCOM, refer to the Microsoft website.

You must set up the client machine to match the access level you chose for the logic analyzer (share-level or user-level access). Refer to the appropriate access type to continue with the setup procedure:

- *Setting Up Share-level Access for Microsoft Windows 95* on page 46.
- *Setting Up User-level Access for Microsoft Windows 95* on page 47.

---

**NOTE.** You can switch between user- and share-level access later by redoing the Setting the Access Level procedure on page 44, from step 3 onward.

---

**Setting Up Share-level Access for Microsoft Windows 95.** To set up share-level access for a client machine running Microsoft Windows 95, do the following procedure on the client machine:

1. Click Start, point to Settings, and select Control Panel.
2. From the Control Panel, select Network, then click the Access Control tab.
3. Choose Share-level access control, and then click OK. If prompted, insert the Windows 95 CD, or provide a file path to the stored Windows 95 files.
4. The System Settings Change dialog appears. Click the Yes button.
5. Click Start, then Shut Down. In the Shut Down Windows dialog box, select Restart the Computer? and then click the Yes button.
6. Navigate to and double-click **<install directory>\System\TPI\Share Level Access Client.reg**.
7. A dialog appears, indicating successful registration. Click OK.
8. Restart the client machine, using the procedure in step 5.
9. In Microsoft Windows 95, click Start and then Run. Either locate the regedit file using Browse, or enter regedit, then click OK to run regedit.
10. Click on the following registry key: HKEY\_CLASSES\_ROOT\AppID\{C67DAA22-4972-11d1-9CAC-00805F0D8271}
11. Using Edit>New>StringValue, add a named value, RemoteServerName.
12. Click the new value, RemoteServerName, and select Edit>Modify. The Edit String dialog appears.
13. Enter the computer name of the logic analyzer. This is the name used to identify the logic analyzer on the network. Click OK.

To verify that the setup is complete, do the following:

1. Navigate to and run **<install directory>\Samples\TPI Samples\Vc++\test client\testclient.exe** on the client machine.
2. The Tektronix Test TPI Client dialog appears. Click the Connect to TLA 700! button to see if the client can connect to the logic analyzer.
3. Attempting Connection to TLA 700 appears in the dialog text box. (The first time you connect, it may take a few minutes.) The text changes to Connected! when the connection is made.

This completes the setup of the logic analyzer and the Windows 95 client machine for running a client application across the network.

**Setting Up User-level Access for Microsoft Windows 95.** To set up user-level access for a client machine running Microsoft Windows 95, do the following procedure:

1. Click Start, point to Settings, and select Control Panel.
2. From the Control Panel, select Network, then select the Access Control tab.
3. Choose User-level access control and enter the name of the domain that will be used to validate user access. Select OK.
4. On the client machine, click Start and then Shut Down. In the Shut Down Windows dialog, select Restart the Computer? and then click the Yes button.
5. Navigate to and double-click **<install directory>\System\TPI\User Level Access Client.reg**.
6. Restart the client machine, using the procedure in step 4.
7. In Microsoft Windows 95, click Start, and then select Run. Either locate the dcomcnfg file using Browse, or enter dcomcnfg in the edit field. Click OK.
8. Double-click “Tektronix TLA 700 Application” in the Applications page.
9. In the Location page, uncheck the “Run application on this computer” box and check the “Run application on the following computer” box. Enter the name of the logic analyzer in the edit field.

To verify that the setup is complete:

1. Run **<install directory>\Samples\TPI Samples\Vc++\test client\test-client.exe** on the client machine.
2. The Tektronix Test TPI Client dialog appears. Click the Connect to TLA 700! button to see if the client can connect to the logic analyzer.
3. Attempting Connection to TLA 700 appears in the dialog text box. (The first time you connect, it may take a few minutes.) The text changes to Connected! when the connection is made.

This completes the setup of the logic analyzer and the client machine for running a client application across the network.

---

**NOTE.** You can switch between share-level and user-level access later by uninstalling the Tektronix TPI Client and DCOM95 by using the Windows 95 control panel. Redo the procedure from step 2 of Setting Up a Client Machine that is Running Microsoft Windows 95 on page 45.

---



### Setting Up a Client Machine that is Running Microsoft Windows NT

After you set up the logic analyzer, you must set up the client machine using the following procedure:

1. Install and configure TCP/IP. (networking)

---

**NOTE.** *If you have difficulty configuring the network setup, contact your system administrator.*

---

2. Load the Tektronix TPI Client Install diskettes supplied with the logic analyzer.
3. Double-click on **Setup.exe**.
4. Click Start and then Shut Down. In the Shut Down Windows dialog, select Restart the Computer? and then click the Yes button.
5. Depending on the type of access control you chose for the logic analyzer, double-click <install directory>\System\TPI\Share Level Access **Client.reg** or **User Level Access Client.reg**.
6. Restart the client machine, using the procedure in step 4.
7. In Microsoft Windows NT, click Start, and then select Run. Either locate the dcomcnfg file using Browse, or enter dcomcnfg. Then click OK.
8. Double-click Tektronix TLA 700 Application in the Applications page.
9. In the Location page, check the “Run application on the following computer” box. Enter the name of the logic analyzer in the edit field.

To verify that the setup is complete, do the following:

1. Run <install directory>\Samples\TPI Samples\Vc++\test client\test-client.exe on the client machine.
2. The Tektronix Test TPI Client dialog appears. Click the Connect to TLA 700! button to see if the client can connect to the logic analyzer.
3. Attempting Connection to TLA 700 appears in the dialog text box. (The first time you connect, it may take a few minutes.) The text changes to Connected! when the connection is made.

This completes the setup of the logic analyzer and the Windows NT client machine for running your client application across the network.

### Setting Up a Client Machine Running on Any Other Platform

If the client application requires use of the type library, you can generate it on your platform using tla700.odl in **C:\Program Files\TLA 700\System\TPI\src** on the logic analyzer.

Make sure that you perform the following steps:

1. Ensure that DCOM is working on your platform.
2. Merge **C:\Program Files\TLA 700\System\TPI\Client.reg** into your registry.
3. Depending on the type of access control you chose for the logic analyzer, merge **C:\Program Files\TLA 700\System\TPI\Share Level Access Client.reg** or **User Level Access Client.reg** into your registry.
4. Add a string value named RemoteServerName to the key  
HKEY\_CLASSES\_ROOT\AppID\  
{C67DAA22-4972-11d1-9CAC-00805F0D8271}
5. Enter the computer name of the logic analyzer as the value of this string.  
This is the name used to identify the logic analyzer on the network.

This completes the setup of the logic analyzer for operating with a remote client machine using a platform other than Microsoft Windows NT or Microsoft Windows 95.

## Updating Module Firmware

Perform the following steps if you need to update or reinstall the flash ROM-based firmware on your application modules. You can update multiple modules and module types during a single firmware update session.

1. Power off the logic analyzer.
2. Disconnect the power cord.
3. Disconnect any probes on the modules that you want to upgrade.
4. Remove the module from the logic analyzer.
5. Refer to Figure 21 and locate the Flash programming pins on the rear of the module.

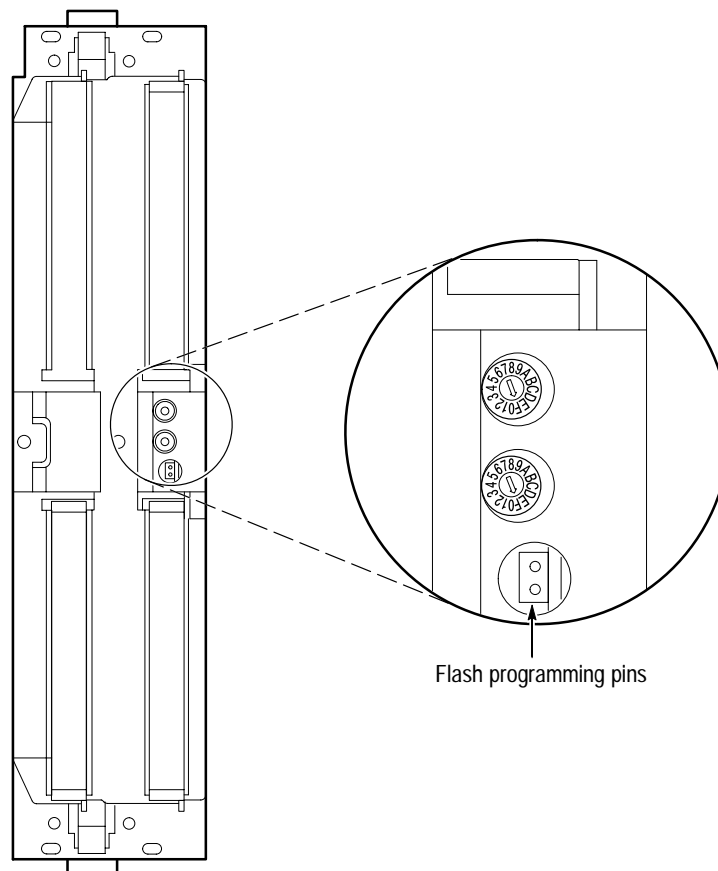

**Figure 21: Flash programming pins**

6. Install a jumper on the Flash programming pins (use one of the spare jumpers that came with your logic analyzer software).

7. Reinstall the modules in the logic analyzer.
8. Reconnect the power cord and power on the logic analyzer.

---

**NOTE.** When the TLA 700 application starts, any modules where you have installed the Flash programming jumper will not display in the system menu.

---

9. Exit the TLA 700 application.
10. Click Start, point to Programs, point to Tektronix TLA 700, and click TLA 700 Firmware Loader.
11. Select the modules that you want to update from the list of modules displayed in the Supported list box near the top of the menu. If you are updating more than one module at a time, note the slot location of the module in the selection box.
12. Select Load Firmware from the Execute menu.
13. Click the proper .LOD file for the module in the C:\Program Files\ TLA 700 Firmware directory. If you are updating more than one module make sure that you select the proper firmware file for the module in the listed slot number.
14. Click Ok. You will be asked to confirm your action; click Yes when prompted.

---

**NOTE.** The program will not allow you to load firmware to an incompatible module. For example, the program will not load DSO firmware to a logic analyzer module.

---

15. If you are updating another module, select the proper .LOD file for the module.
16. Click Ok. You will be asked to confirm your action; click Yes when prompted.  
  
The program will load the firmware for each module one at a time. The process takes approximately five minutes per module.
17. When the load operation is complete, select each of the modules in the Supported list and then select Checksum from the Execute menu.
18. If each module passes the checksum test, exit the program.
19. Power off the logic analyzer and disconnect the power cord.

20. Remove the module from the logic analyzer and remove the jumper from the Flash programming pins on the rear of the module. Keep the jumper for future updates.
21. Attach a new label with the new firmware version to the module.
22. Reinstall the module in the logic analyzer and reconnect the probes.
23. Reconnect the power cord and power on the logic analyzer.
24. Verify that the power-on diagnostics pass.
25. Run the self calibration on each module after a 30-minute warm-up.

## Controller BIOS Setup

The logic analyzer has a built-in setup program where you can set some basic input and output characteristics. In most cases, there is no need to access the setup program. If you need to access the setup program, power on the logic analyzer and press function key F2 on the keyboard (ALT, CTRL, F2 keys simultaneously on the portable mainframe front panel) before the logic analyzer boots the Windows 95 operating system.

Table 6 on page 53 lists the default settings for the BIOS setup. You may need to refer to this information after updating the software or making other changes.



**CAUTION.** Do not change any of the settings if you are unfamiliar with the setup program. Selecting an incorrect setup can cause the logic analyzer to malfunction.

---

If you need to change any of the settings to match those listed in Table 6, follow the on-screen instructions.

---

**NOTE.** If you need to upgrade the Controller BIOS version, refer to the Maintenance chapter of the TLA 711 Color Benchtop Controller Service Manual or the TLA 704 Color Portable Mainframe Service Manual for the upgrade instructions.

---

Table 6: Controller BIOS setups for the TLA 700 application

Parameter	Factory setting	Submenu parameter	Factory setting
<b>Main menu</b>			
System Time	Set to current date		
System Date	Set to current time		
Diskette A	1.44 MB, 3 1/2		
Diskette B	Not Installed		
IDE Adapter 0 Master	(C:[hard disk size])	Autotype Fixed Disk	Select Enter
		Type	Hard disk size
		Cylinders	Number of cylinders
		Heads	Number of heads
		Sectors/track	Number of sectors/track
		Write Precomp	None
		Multi-sector transfers	Set by Autotype
		LBA Mode Control	Set by Autotype
		32-Bit I/O	Disabled
		Transfer Mode	Set by Autotype
IDE Adapter 0 Slave	(None)		
IDE Adapter 1 Master	(None)		
IDE Adapter 1 Slave	(None)		
Video System	EGA/VGA		
Memory Cache		External Cache	Enabled
		Cache System BIOS area:	Enabled
		Cache Video BIOS area:	Enabled
		Cache Memory Region	
		CC00 – CFFF:	Disabled
		D000 – D3FF:	Disabled
		D400 – D7FF:	Disabled
		D800 – DBFF:	Disabled
		DC00 – DFFF:	Disabled
Memory Shadow		System Shadow	Enabled
		Video Shadow:	Enabled
		Regions with Legacy Expansion ROMS	
		CC00 – CFFF:	ROM

Table 6: Controller BIOS setups for the TLA 700 application (Cont.)

Parameter	Factory setting	Submenu parameter	Factory setting
		D000 – D3FF:	ROM
		D400 – D7FF:	ROM
		D800 – DBFF:	ROM
		DC00 – DFFF:	ROM
Boot Sequence:	A: then C:	Boot Delay	0
		Boot Sequence:	A: then C:
		Setup Prompt	Enabled
		POST Errors	Enabled
		Floppy Check	Enabled
		Summary Screen	Enabled
NUMLOCK:	OFF	NUMLock	Off
		Key Click	Disabled
		Keyboard auto-repeat rate	30/sec
		Keyboard auto-repeat delay	1/4 sec
System Memory	640 KB		
Extended Memory	<i>Installed memory – 640 K</i>		
<b>Advanced menu</b>			
Integrated Peripherals		COM A	3F8, IRQ4
		COM B	2F8, IRQ3
		LPT Port	378, IRQ7
		LPT Mode	ECP
		Diskette Controller	Enabled
		Local Bus IDE Adapter	both
Advanced Chipset Control		DRAM Speed	60 ns <sup>1</sup>
		DMA Aliasing	Enabled
		8 Bit I/O Recovery	4.5
		16 Bit I/O Recovery	4.5
		IRQ12 Used By	PS/2 Mouse
		ECC/Parity	Disabled
Plug & Play O/S	No		
Reset Configuration Data	No		
Large Disk Access Mode:	DOS		
Enable SimulScan Mode:	Disabled		

Table 6: Controller BIOS setups for the TLA 700 application (Cont.)

Parameter	Factory setting	Submenu parameter	Factory setting
Flash ATA PC Card Booting:	Disabled		
<b>Power menu</b>			
APM:	Enabled <sup>2</sup>		
Power Savings	Customize <sup>3</sup>		
Standby Timeout:	Disabled		
Suspend Timeout:	Disabled		
Standby CPU Speed:	MAX		
Fixed Disk Timeout:	Disabled		
CRT:	ON		
Standby Timer Reset Events			
Keyboard	Enabled		
Mouse	PS/2 (IRQ12)		
Standby Break Events			
IRQ0	Disabled		
IRQ1	Auto		
IRQ3	Auto		
IRQ4	Auto		
IRQ5	Disabled		
IRQ6	Disabled		
IRQ7	Disabled		
IRQ8	Disabled		
IRQ9	Disabled		
IRQ10	Disabled		
IRQ11	Disabled		
IRQ12	Auto		
IRQ13	Disabled		
IRQ14	Disabled		
IRQ15	Disabled		
Standby Wakeup Events			
Keyboard	Enabled		



Table 6: Controller BIOS setups for the TLA 700 application (Cont.)

Parameter	Factory setting	Submenu parameter	Factory setting
Mouse	PS/2 (IRQ12)		

- 1 DRAM speed was set to 70 ns for TLA 700 Series controllers with BIOS version 1.00.11 or earlier.
- 2 APM is set to Disabled for TLA 700 Series controllers with BIOS version 1.00.11 or earlier.
- 3 Power Savings is set to Customize when the APM is enabled. This allows Windows to manage power use for the instrument as indicated on the Power property page of the Power icon in the Control Panel. Power Savings was set to Disabled with BIOS version 1.00.11 or earlier.

## Reinstalling Software

There may be occasions when you have to reinstall software or restore software after replacing the hard disk. The procedures in this section explain how to reinstall software on the hard disk. If you replace the hard disk, you must also configure the controller BIOS. To configure the controller BIOS, follow steps under *Configure the Controller BIOS* on page 56.

On rare occasions you may need to reformat the hard disk. If so, follow the steps under *Reformatting the Hard Disk* on page 57. Otherwise, follow the steps under *Reinstalling the Windows 95 Software* on page 58.

---

**NOTE.** You should perform all of the procedures in this section in sequence.

---

### Configure the Controller BIOS

This procedure is necessary after replacing the hard disk or when the CMOS settings are corrupted or lost. You will need the the emergency startup disk that you created when you installed your logic analyzer (see *Create an Emergency Startup Disk* on page 13). To configure the Controller BIOS, complete the following steps:

1. Power off the logic analyzer and insert the emergency startup disk in the floppy disk drive.
2. Power on the logic analyzer.
3. When prompted, press function key F2 on the keyboard before the logic analyzer boots the Windows 95 operating system.
4. In the Main Setup menu, use the Down Arrow key to scroll to the line labeled **IDE Adapter 0 Master**.
5. Press the Enter key to display the hard disk detail submenu.

6. Press the Enter key again to cause the logic analyzer to automatically determine and set the hard disk drive parameters.
7. Press the ESC key twice and then the Enter key twice to exit and save the BIOS setup.

## Reformatting the Hard Disk

You should not reformat your hard disk drive unless it is absolutely necessary. If you find that you need to format the hard disk, (if possible) make sure that you have backup copies of your user files so that you can reinstall them later.

You must perform the following procedure after you replace the hard disk, or when the partitioning or the format of the hard disk has been damaged. You will use the Setup program on the Windows 95 Setup Boot floppy disk to partition and format the hard disk.

Complete the following steps to format the hard disk:

1. Insert the Windows 95 Setup Boot floppy disk in the floppy disk drive.
2. Power on the logic analyzer so that it boots from the floppy disk.
3. Press function key F3 to exit the Setup program; press F3 again to confirm your selection.

You must temporarily exit the Setup program to properly execute the FDISK command with the /X switch. If you do not execute the FDISK /X command separately, the primary DOS partition will not be compatible with the TLA 700 Series BIOS.

4. At the prompt, enter the command FDISK /X.
5. Enter N when you are asked if you want to select Large Disk Support.
6. Select option 1 to create a new partition on the hard disk.
7. Select option 1 again to specify that the new partition is to be the primary DOS partition.
8. Enter Y to use the maximum available size for the DOS partition.
9. Press the CTRL, ALT, and Delete keys simultaneously to reboot the logic analyzer and restart the Setup program.

When the Setup program restarts, it will caution you that there is an operating system already installed. Disregard this message. The message appears because you partitioned the hard disk in the previous steps.

10. Continue with the Setup program and follow the instructions on the display. The Setup program will format the hard disk and exit the program when complete.

### Reinstalling the Windows 95 Software

The following procedure assumes that the hard disk is already properly formatted. To reinstall the Windows 95 software, complete the following steps:

1. Start the logic analyzer from the Windows 95 Setup Boot floppy disk.
2. When the install program prompts you for an installation, select Typical.
3. Enter the Windows 95 Product Identification number located above the bar code on the Windows 95 software package.
4. Enter your name when prompted.
5. Enter your company name when prompted (optional).
6. When prompted, select the appropriate hardware categories (for example, Network).
7. Install the Windows 95 floppy disks one at a time until you have installed all of the floppy disks.
8. Enter the current date, time, and time zone when prompted.
9. Restart the logic analyzer when prompted. The logic analyzer should start up in Windows 95. You are now ready to install the TLA 700 Series application software.

### Set the Display Driver

After installing the Windows 95 software, you must set the display driver for your monitor. Otherwise, using the default display driver may not provide the optimum display settings. To set the display driver, complete the following steps:

1. Click Start, point to Settings, click on Control Panel, and open the Display icon.
2. Select the Settings property page.
3. Click on the Advanced Properties button.
4. Select the Adapter tab page, and then click on the Change button.
5. Click on the Have Disk button.
6. Insert the floppy disk labeled **Cirrus Logic Video Display Driver GDS7543 – Rel 2.40 for Windows 95** and click OK.
7. Select the driver named **Cirrus Logic 7543 2.40 PCI(Cirrus)** and then click OK.

---

**NOTE.** If a Version Conflict dialog box appears and asks you if you want to keep the file, answer Yes.

---

8. After the installation is complete, close all of the dialogs and property sheets. However, keep the Control Panel open.
9. When the prompt appears asking you if you want to reboot now, enter No.

### Reinstall the QAPLus Diagnostic Software

To reinstall the QAPLus diagnostic software, complete the following steps:

1. Insert the QAPLus floppy disk into the disk drive.
2. In the Control Panel window, double-click Add/Remove Programs.
3. Click on the Install button to begin installing the software.
4. When the program prompts you to confirm the creation of the C:\win-win directory, click Continue.

---

***NOTE.** If you use a set of QAPLus disks which have been previously installed, you will not be able to enter a user name. The program will warn you that the disks have been previously installed and then ask you to acknowledge that fact before proceeding.*

---

5. When the program asks you if you want to create a set of icons for the program manager, click Create.  
  
After completing the installation, the program opens up the Notepad application and displays the release notes for the QAPLus software.
6. Close the Notepad application and press the CTRL, ALT, and Delete keys simultaneously to display a list of current tasks.
7. Select the QAPLus task, and click End task to kill the task.
8. After a few seconds, a dialog box displays advising you that the application is not responding. Click End Task again to kill the application.
9. When the desktop reappears, close the Program Manager folder.
10. Click Start, point to Programs, and click on MS-DOS Prompt to open an MS-DOS window.
11. In the MS-DOS window, change directories to the C:\win-win directory.
12. Insert the QAPLus/WIN disk labeled **QAPLus\win-win Manual Version 7.01**.
13. Copy the file A:\Qawwusro.exe to the C:\win-win directory.
14. Exit and close the MS-DOS window.

### **Reinstall the TLA 700 Series Application Software**

To reinstall the TLA 700 Series application software, complete the following steps:

1. Insert the TLA 700 application floppy disk 1 in the disk drive.
2. Click Start, point to Settings, and click on Control Panel.
3. In the Control Panel window, double-click Add/Remove Programs.
4. Click on the Install button and follow the instructions on the screen for installing the software from the floppy disk.
5. When the installation is complete, the program will prompt you to reboot the system; click on OK to reboot.

### **Reinstalling other Application Software**

To reinstall any other application software such as microprocessor support software, complete the following steps:

1. Insert the first floppy disk into the disk drive.
2. Click Start, point to Settings, and click Control Panel.
3. In the Control Panel window, double-click Add/Remove Programs.
4. Click on the Install button and follow the instructions on the screen for installing the software from the floppy disk.

### **Restoring User Files**

After you have reinstalled all of the application software files, you should restore any backed-up user files. Use the Windows 95 Back Up tool to restore any saved files from floppy disks. Use the online help for instructions on restoring the files.

## Customizing TLA 700 Series Setups

After restoring all of the user and application files, you must perform the following steps to complete the software installation process. The steps in this section will return your logic analyzer to the same settings it had when it was shipped from the factory. The following steps are included in this section:

- Creating a shortcut for the QAPlus online manual
- Adjusting the display desktop settings for an external monitor
- Adjusting the refresh rate
- Setting up the screen saver
- Setting up the Virtual Memory

---

***NOTE.** You must exit the TLA 700 Application before completing the procedures in this section. The TLA 700 Application starts automatically each time you power on the logic analyzer.*

---

### Create a Shortcut for the QAPlus Online Manual

Complete the following steps to create a shortcut from the Start menu for the QAPlus online manual:

1. Use the Windows Explorer (right-click on Start and select Explore) to open the directory C:\Windows\Start Menu\Programs\QAPlus\_WIN-WIN.
2. Select the QAPlus\_WIN-WIN directory. From the File menu, select New and then Create Shortcut.
3. Enter the name of the file C:\WIN-WIN\Qawwusro.exe in the field of the Create Shortcut dialog.
4. Click Next and set the name of the shortcut to QAPlus\_WIN-WIN Manual.
5. Click Finish to install the shortcut in the Start menu.
6. Close the Windows Explorer.

### Adjust the Display Desktop Settings for an External Monitor

The following steps are only necessary if your logic analyzer uses an external monitor. The following steps are a generalized procedure for a standard Plug & Play monitor. If you know the type of monitor that you will use, select the monitor type in steps 6 and 7 and adjust the remaining parameters for your specific monitor.

1. Click Start, point to Settings, click on Control Panel, and open the Display icon.
2. Select the Settings property page.
3. Click on the Advanced Properties button.
4. Select the Monitor tab page and then click on the Change button.
5. Click on the radio button to Show All Devices.
6. Select **Standard Monitor Types** under the Manufacturers column.
7. Select **Plug & Play Monitor** under the Model Type column.
8. Click OK to close the selection window.
9. Click Close to close the Advanced Properties dialog.
10. Set the following parameters in the Settings property page:

■ Color Palette	256 Colors
■ Desktop Area	640 x 480
11. Leave the Display property page open and continue with the next procedure to adjust the refresh rate.

### Adjust the Refresh Rate

A higher monitor refresh rate provides a brighter, clearer display. It also reduces eye fatigue from screen flicker. The following recommendations set the refresh rate to the highest possible settings and may not be optimal for all display types. You may want to try different settings to determine which work best for your specific monitor.

1. Select the Monitor Refresh property page.
2. Click the Set Highest button to use the highest available refresh rate for each desktop selection.
3. Click OK to close the Monitor Refresh property page.

You will see a warning dialog informing you that the new settings are about to be tested and that the refresh settings will revert to the old settings within 10 seconds if you do not confirm them.

4. Click OK. After the new settings are in effect, click Yes to keep the new settings.
5. Leave the Display property page open and continue with the next procedure to select and configure the screen saver.

### Set Up the Screen Saver

The screen saver includes the option of reducing the intensity of the TLA 700 Series LCD display backlight to help prolong the life of the display. Select this recommended screen saver unless you will always use an external monitor.

1. Select the Screen Saver property page.
2. Select **Tektronix LCD Saver** from the list of screen savers.
3. Set the Wait period for ten minutes.
4. Click the Settings button to open the screen saver dialog.
5. Set the speed to **Fast** and the Intensity to **Reduced (60%)**.
6. Click OK to close the dialog.
7. Click OK to close the Display window.

### Set Up the Mainframe Utilities

The Mainframe Utilities provide additional settings for your logic analyzer (the utilities can only be used with the portable mainframe).

1. Click Start, point to Settings, click on Control Panel, and open the Mainframe Utilities icon.
2. Select the Power Off Mode tab page.
3. Click on the radio button named **Enable Soft Power Off**.
4. Select the LCD Mode tab page.
5. Click on the radio button named **LCD Full On**.
6. Click OK to close the utility.



### Setup the Virtual Memory

The following virtual memory settings ensure optimal performance of the TLA 700 Series application software.

1. Open the System icon in the Control Panel.
2. Select the Performance property page and select the Virtual Memory button.
3. In the Virtual Memory dialog, click the radio button **Let me specify my own virtual memory settings**.
4. Enter a minimum value of 100 MB and a maximum value of 500 MB.
5. Click OK to close the dialog.
6. Select Yes to when prompted to confirm your settings.
7. Click OK to close the System window.
8. When the prompt appears asking you if you want to reboot now, enter No.

### Enable 32-Bit Support for the PCMCIA Interface

Perform the following steps to enable the 32-bit support for the PCMCIA Interface:

---

***NOTE.** You should complete this procedure even if you do not intend to use the PCMCIA interface.*

---

1. Open the System icon in the Control Panel.
2. Select the Performance property page and then click on the text **PC card (PCMCIA) devices are not using 32-bit support**.
3. Click on the Details button.
4. In the Help window, click on the button to enable 32-bit PC card support.
5. When asked if you are using a PC card to install Windows, select No and click Next.
6. When asked to review system files to select real-mode PC card drivers for Windows to delete, select No and click Next.
7. Close the Help window.
8. Click Finish.
9. When asked if it is ok to shut down the computer to complete the installation of 32-bit support, select Yes.

# Appendix C: Power Cord and Line Fuse Requirements for the Benchtop Mainframe

The benchtop mainframe comes with two power cords and three fuses (one fuse is already installed). You must determine the correct fuse and power cord for your configuration. This is important to avoid overloading the power distribution system and ensures that you comply with the National Electrical Code.

The power consumption depends on the number and type of instrument modules installed in the benchtop mainframe. Table 7 lists the power consumed for each module.

To determine the total power consumption perform the following steps:

1. Use Table 7 to determine the power consumption for each module in the benchtop mainframe.
2. Add the power for each module to determine the total power consumption.
3. Determine at which line voltage you will be operating the mainframe.
4. Refer to Figure 22 on page 66 to determine the proper power cord and line fuse for your mainframe.

**Table 7: Power for instrument modules**

Module type	Power (watts)
Benchtop Controller	40
TLA 7L1	55
TLA 7L2	73
TLA 7L3	94
TLA 7L4	109
TLA 7M1	57
TLA 7M2	76
TLA 7M3	99
TLA 7M4	115
TLA 7D1	56
TLA 7D2	81
TLA 7E1	56
TLA 7E2	81

For power usage in the nonshaded region of Figure 22, use either the power cord with the 15 A plug (two parallel prongs and ground) or the power cord with the 20 A plug (two perpendicular prongs and ground). For high power usage combined with low input line voltages (shaded region), use only the power cord with the 20 A plug. Select the proper fuse based on the ranges shown in Figure 22.

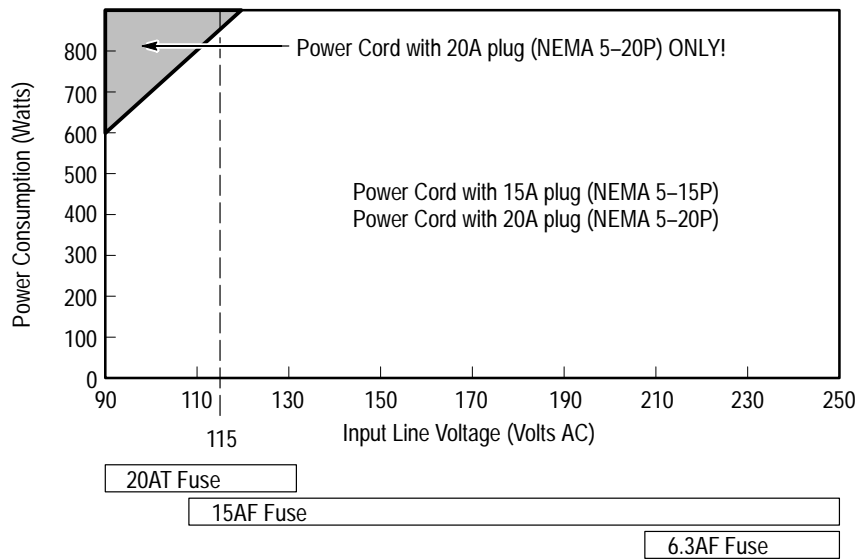

Figure 22: Power cord identification chart

For example, assume that your configuration consists of four TLA 7M4 Logic Analyzer Modules and one TLA 7E2 DSO Module. Also assume that you will be operating the mainframe at 90 VAC.

Add 40 watts (for the controller) + 81 watts (for the DSO Module) + 4 X 115 watts (for the logic analyzer modules) to come up with a total value of 581 watts. Because the power consumption (at 90 VAC) is approaching the shaded area of the graph in Figure 22, you should consider using the 20A power cord.



## Artisan Technology Group is your source for quality new and certified-used/pre-owned equipment

- FAST SHIPPING AND DELIVERY
- TENS OF THOUSANDS OF IN-STOCK ITEMS
- EQUIPMENT DEMOS
- HUNDREDS OF MANUFACTURERS SUPPORTED
- LEASING/MONTHLY RENTALS
- ITAR CERTIFIED SECURE ASSET SOLUTIONS

### SERVICE CENTER REPAIRS

Experienced engineers and technicians on staff at our full-service, in-house repair center

### *InstraView*<sup>SM</sup> REMOTE INSPECTION

Remotely inspect equipment before purchasing with our interactive website at [www.instraview.com](http://www.instraview.com) ↗

### WE BUY USED EQUIPMENT

Sell your excess, underutilized, and idle used equipment. We also offer credit for buy-backs and trade-ins. [www.artisanng.com/WeBuyEquipment](http://www.artisanng.com/WeBuyEquipment) ↗

### LOOKING FOR MORE INFORMATION?

Visit us on the web at [www.artisanng.com](http://www.artisanng.com) ↗ for more information on price quotations, drivers, technical specifications, manuals, and documentation

**Contact us:** (888) 88-SOURCE | [sales@artisanng.com](mailto:sales@artisanng.com) | [www.artisanng.com](http://www.artisanng.com)