



Artisan Technology Group is your source for quality new and certified-used/pre-owned equipment

- FAST SHIPPING AND DELIVERY
- TENS OF THOUSANDS OF IN-STOCK ITEMS
- EQUIPMENT DEMOS
- HUNDREDS OF MANUFACTURERS SUPPORTED
- LEASING/MONTHLY RENTALS
- ITAR CERTIFIED SECURE ASSET SOLUTIONS

SERVICE CENTER REPAIRS

Experienced engineers and technicians on staff at our full-service, in-house repair center

*InstraView*SM REMOTE INSPECTION

Remotely inspect equipment before purchasing with our interactive website at www.instraview.com ↗

WE BUY USED EQUIPMENT

Sell your excess, underutilized, and idle used equipment. We also offer credit for buy-backs and trade-ins. www.artisanng.com/WeBuyEquipment ↗

LOOKING FOR MORE INFORMATION?

Visit us on the web at www.artisanng.com ↗ for more information on price quotations, drivers, technical specifications, manuals, and documentation

Contact us: (888) 88-SOURCE | sales@artisanng.com | www.artisanng.com



p/n YPM08117

ACR2000 Hardware Manual

Effective: October 7, 2002



This page intentionally left blank.

CHANGE NOTICE

ACR2000 Hardware Manual P/N PM08117 Version Change:

From: Version 1.08, Dated 5/24/2000

To: Version 1.09, Dated 12/7/2001

1. Page 11, Digital Output Sink/Source Select Jumpers (J7 and J8) Added Sinking Output Driver chip source.
2. Page 26, ACRCOMM Serial Communications Corrected MUX Flag table.
3. Page 36, ACR2000 Technical Specification Corrected operating temperature range. Added tolerances to power consumption values.

ACR2000 Hardware Manual P/N PM08117 Version Change:

From: Version 1.07, Dated 9/30/1999

To: Version 1.08, Dated 5/24/2000

1. ACR2000, ACRIO Section Removed ACRIO section. ACRIO board has separate hardware manual.

ACR2000 Hardware Manual P/N PM08117 Version Change:

From: Version 1.06, Dated 7/8/1999

To: Version 1.07, Dated 9/30/1999

1. Page 5, ACR2000 Motherboard Hardware Added U14/U15 Digital Output Driver locations to Figure 1.
2. Page 6, ACR2000 Motherboard Jumpers Added jumper reference table.
3. Page 11, ACR2000 Motherboard Jumpers – Digital Output Added warning about installing jumpers with wrong output driver IC's.
4. Page 25, ACRCOMM Module Added communications set-up details.
5. Page 27, ACRCOMM Hardware Setup Updated outline drawing to include LED's and unused jumpers.
6. Page 28, ACRCOMM Module Jumpers Added jumper reference table.
7. Page 30, ACRCOMM Module Jumpers – Battery Enable Jumpers (J5 and J6) Added reference and replacement options to first paragraph.
8. ACRCOMM Module Jumpers – Extended Card Address Jumper (J8) Removed J8 Jumper Reference information
9. Page 33, ACRCOMM Module Hardware Wiring – Standalone Power (PWR2) Added LED reference to PWR2 table.
10. ACRIO Module Hardware Added U1 thru 4 Digital Output Driver locations to Figure 5.
11. ACRIO Module Jumpers Added jumper reference table.
12. ACRIO Module Jumpers – Digital Output Added warning about installing jumpers with wrong output driver IC's. Corrected IC reference designations.

CHANGE NOTICE, continued

ACR2000 Hardware Manual P/N PM08117 Version Change:

From: Version 1.05, Dated 5/20/1998

To: Version 1.06, Dated 7/8/1999

1. ACR2000 Motherboard Jumpers – Digital Input Reference Select Jumper (J5) Removed +5VDC reference.
2. ACR2000 Motherboard Jumpers – Digital Output Sink/Source Select Jumpers (J7 and J8) Removed +5VDC reference. Added jumper warning.
3. ACR2000 Motherboard Hardware Wiring Removed +5VDC reference.
4. ACR2000 Motherboard Hardware Wiring, Digital I/O Power (PWR1) Removed +5VDC reference.
5. Chapter 3 Overview Removed +5VDC reference.
6. ACRIO Module Jumpers – Digital Input Reference Select Jumpers (J3 and J4) Removed +5VDC reference.
7. ACRIO Module Jumpers – Digital Output Sink/Source Select Jumpers (J5 and J6) Removed +5VDC reference. Added jumper warning.
8. ACRIO Module Hardware Wiring, Digital I/O Power (PWR1) Removed +5VDC reference.

CHANGE NOTICE, continued

ACR2000 Hardware Manual P/N PM08117 Version Change:

From: Version 1.04, Dated 1/19/98

To: Version 1.05, Dated 5/20/98

The following changes have been incorporated into ACR2000 Hardware Manual Version 1.05:

1. ACR2000 Motherboard Switches – Address Selection Switch (SW1) Added Flash Bypass Mode information.
2. ACR2000 Motherboard Hardware Wiring – Analog Input/Output (P2) Added Stepper Output fuse information.
3. ACRIO Digital I/O Power (PWR1) Corrected the Isolated Power Fuse current rating from “2 Amps” to “4 Amps”.
4. ACR2000 Specification Corrected the DAC/Stepper Output Step Output frequency specification.
5. ACR2000 Specification Corrected the Digital Outputs specification.
6. ACRIO Specification Added ACRIO Specification.
7. ACRIO Module Mechanical Dimensions Corrected the ACRIO mechanical dimension from the top of the board to the center of the bottom hole. Changed the value from “3.700” to “3.750”.
8. ACR2000 Typical Connection Diagrams Corrected the Multiple Board RS-232 diagram on ACR2000 Wiring Diagram page1.

Corrected the Stepper Output open-collector drivers from “7407” to “7406” in ACR2000 Wiring Diagram page 2.

This page intentionally left blank.

TABLE OF CONTENTS

INTRODUCTION.....	1
CHAPTER 1.....	3
ACR2000 MOTHERBOARD HARDWARE SETUP	3
Chapter 1 Overview	4
ACR2000 Motherboard Switches	6
Address Selection Switch (SW1).....	6
ACR2000 Motherboard Jumpers	7
ACR2000 Jumper Table List	7
Encoder Pull-up Select Jumpers (J1 thru J4).....	8
Digital Input Reference Select Jumper (J5)	9
Digital Output Sink / Source Select Jumpers (J7 and J8).....	11
EPROM Size Select Jumpers (J9 and J12)	13
Battery Back-Up Select Jumpers (J10 and J11).....	14
Interrupt Select Jumper (J13).....	15
ACR2000 Motherboard Hardware Wiring.....	16
Encoder Inputs (P1).....	17
Analog Input / Output (P2)	19
Digital Inputs / Outputs (P3).....	21
Digital I/O Power (PWR1).....	22
CHAPTER 2	23
ACRCOMM MODULE HARDWARE SETUP (OPTIONAL)	23
Chapter 2 Overview	24
ACRCOMM Serial Communications	25
ACRCOMM Module Jumpers	28
ACRCOMM Jumper Table List.....	28
RS-422 Termination Jumpers (J1 thru J4).....	29
Battery Enable Jumpers (J5 and J6).....	30
Autobaud Detect Jumper (J7)	31
ACRCOMM Module Hardware Wiring (Optional).....	32
ACRCOMM Standalone Power (PWR2)	33
ACRCOMM Communications (P5)	34
CHAPTER 3	35
ACR2000 SPECIFICATION.....	35
ACR2000 Specification.....	36
CHAPTER 4	39
ACR2000 MECHANICAL DRAWINGS.....	39

ACR2000 Mechanical Dimensions	40
ACRCOMM Module Mechanical Dimensions	41
ACR2000 Board Stacking Examples	42
ACR2000 Typical Connection Diagrams.....	43

TABLES

Table 1.1	ACR2000 PC BUS Status Port Bits	6
Table 1.2	ACR2000 PC BUS Port Addresses.....	6
Table 1.3	ACR2000 Encoder Pull-Up Jumpers	8
Table 1.4	ACR2000 Digital Input Reference Jumper	9
Table 1.5	ACR2000 Digital Output Sink/Source Select Jumper	11
Table 1.6	ACR2000 EPROM Size Select Jumpers.....	13
Table 1.7	ACR2000 Battery Back-Up Enable Jumpers	14
Table 1.8	ACR2000 PC BUS Interrupt Select Jumpers.....	15
Table 1.9	ACR2000 Encoder Input Connector	17
Table 1.10	ACR2000 Analog I/O Connector.....	19
Table 1.11	ACR2000 Isolated Power Fuses.....	20
Table 1.12	ACR2000 Digital I/O Connector.....	21
Table 1.13	ACR2000 Isolated Power Connector	22
Table 1.14	ACR2000 Isolated Power Fuses.....	22
Table 2.1	ACRCOMM RS-422 Termination Jumpers	29
Table 2.2	ACRCOMM Battery Selection Jumpers	30
Table 2.3	ACRCOMM Autobaud Detect Jumper.....	31
Table 2.3	ACRCOMM Standalone Power Connector	33
Table 2.4	ACRCOMM Standalone Power Fuses.....	33
Table 2.5	ACRCOMM Communications Connector.....	34

FIGURES

Figure 1. ACR2000 Motherboard Outline.....	5
Figure 2. ACR2000 Digital Input User Circuit.....	10
Figure 3. ACR2000 Digital Output User Circuit.....	12
Figure 4. ACRCOMM RS-422 Interface Schematic.....	26
Figure 5. ACRCOMM Module Outline.....	27
Figure 6. ACR2000 Mechanical Dimensions.....	40
Figure 7. ACRCOMM Mechanical Dimensions.....	41
Figure 8. ACR2000 Board Stacking Mechanical Dimensions Examples.....	42

INTRODUCTION

This document provides hardware connection information for the Acroloop ACR2000 motion controller.

Included in this document is the hardware connection information for the following optional plug-in modules:

- a. ACRCOMM module. This board is required for stand-alone operation of the ACR2000 motion controller. Power supply input, battery back-up, and communication ports are provided by this board.

Refer to separate ACRIO Hardware Manual – Reverse Layout, P/N PM08124:

- a. ACRIO module. This board provides expanded I/O capabilities for the ACR2000 motion controller. An additional 32 Digital Inputs and 32 Digital Outputs are provided by this board. Up to four expanded I/O boards can be piggy-backed, for a total of 288 digital I/O.

This page intentionally left blank.

CHAPTER 1

ACR2000 MOTHERBOARD HARDWARE SETUP

CHAPTER 1 OVERVIEW

This section contains diagrams of the jumpers and switches on the ACR2000 mother board.

Encoder pull-up jumpers must be set correctly based on the types of encoders being used. Failure to set these jumpers correctly may cause damage to the encoders or to the receivers on the controller card.

There are no analog adjustment “pots” on the board. All analog gain and offset is under software control. The analog outputs must be wired to differential control signal inputs on a servo amplifier. The DAC SIMM module outputs provide an analog control voltage of ± 10 volts.

Stepper SIMM module outputs provide open-collector step and direction signals. There are no pull-up resistors provided on the Stepper outputs.

Factory default jumper settings for the ACR2000 motherboard are highlighted within the following jumper tables.

ACR2000 MOTHERBOARD HARDWARE SETUP

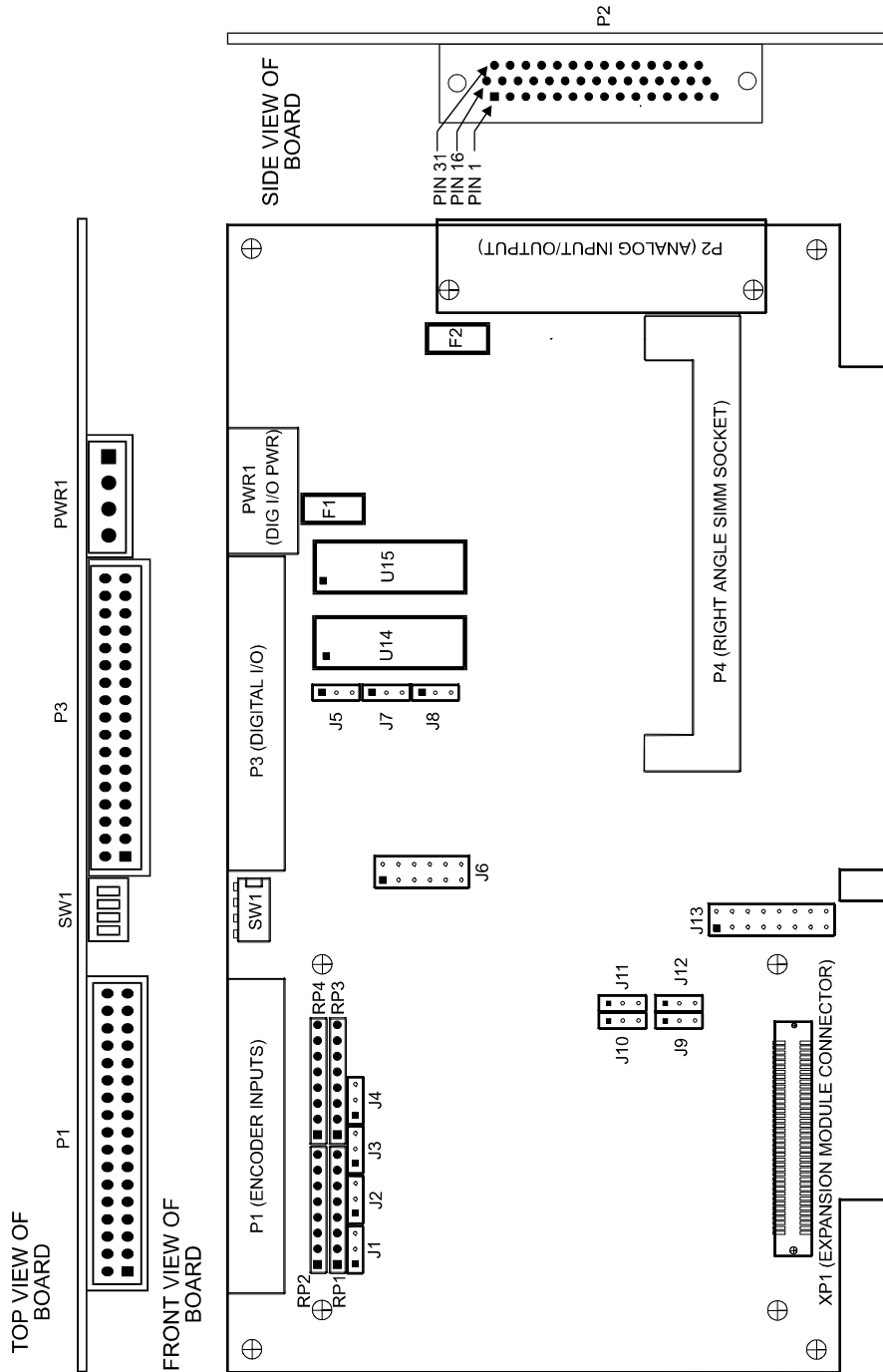

NOTE: Square pin indicates Pin 1.

Figure 1. ACR2000 Motherboard Outline

ACR2000 MOTHERBOARD SWITCHES

Address Selection Switch (SW1)

The ACR2000 can receive and transmit data through I/O ports on a PC BUS. The addresses of these ports are selectable using SW1 on the ACR2000 motherboard. The data port is used to both transmit and receive. Both the transmit and receive channels are connected to 512 byte First In / First Out (FIFO) hardware buffers.

Refer to Figure 1 for switch location.

The status port is used to see if data is waiting to be received from the card and if it is OK to send data to the card. The byte read from the status port is defined as follows:

BIT	Definition	Description
BIT7	Transmit Not Full	Clear to send one byte
BIT6	Transmit Not Half Empty	Clear to send up to 255 bytes
BIT5	Receive Not Empty	Data Available
BIT4	Transmit Not Empty	Still something in the buffer

Table 1.1 ACR2000 PC BUS Status Port Bits

The following table shows how the switch positions relate to the ACR2000 card number and I/O port addresses.

Note that Switch 4 should be left in the “OFF” position, unless using the Flash Bypass Mode of operation. Flash Bypass Mode is selected when the user does not want to load the program information from flash at power-up or reset. The card will not communicate via the PC BUS at Card Number 15, so after the board is powered-up or reset in Flash Bypass Mode, the SW1 settings must be placed back to a valid card number. Serial communications via the COM1 and COM2 communication ports on the ACRCOMM module will recognize the card as Card Number 15. However, the card should be placed back to a valid card number during normal operation.

Card Number	SW1 Settings				Addresses	
	4	3	2	1	Data	Status
0	OFF	OFF	OFF	OFF	0x300	0x302
1	OFF	OFF	OFF	ON	0x304	0x306
2	OFF	OFF	ON	OFF	0x308	0x30A
3	OFF	OFF	ON	ON	0x30C	0x30E
4	OFF	ON	OFF	OFF	0x310	0x312
5	OFF	ON	OFF	ON	0x314	0x316
6	OFF	ON	ON	OFF	0x318	0x31A
7	OFF	ON	ON	ON	0x31C	0x31E
8-14	RESERVED					
15	ON	ON	ON	ON	Flash Bypass Mode	

Table 1.2 ACR2000 PC BUS Port Addresses

ACR2000 MOTHERBOARD JUMPERS

Jumper Table List

The following is a list of the jumper functions on the ACR2000 motherboard:

JUMPER	JUMPER FUNCTION
J1	ENC0 Pull-up Voltage Select (Page 7)
J2	ENC1 Pull-up Voltage Select (Page 7)
J3	ENC2 Pull-up Voltage Select (Page 7)
J4	ENC3 Pull-up Voltage Select (Page 7)
J5	Digital Input Sinking/Sourcing Select (Page 9)
J6	Factory Test Header**
J7	Digital Output Sinking/Sourcing Select (Page 11)
J8	Digital Output Sinking/Sourcing Select (Page 11)
J9	Factory Set Firmware Eprom Size Select (Page 13)
J10	Battery Back-up Enable Select (Page 14)
J11	Battery Back-up Enable Select (Page 14)
J12	Firmware Eprom Size Select (Page 13)
J13	ISA Interrupt Select (Page 15)

** Connecting external signals to this header may cause board failure or damage to IC's.

ACR2000 MOTHERBOARD JUMPERS

Encoder Pull-up Select Jumpers (J1 thru J4)

The ACR2000 is capable of handling various types of incremental open-collector and line driver encoders. Care must be taken to setup each channel to match the encoder type as described below:

Open Collector Encoders:

When using open-collector encoders, the encoder channels must be pulled to either +5 or +12 volts, depending upon the application. Pulling up to +12 volts provides higher noise immunity, but causes a slower response time. For high frequency applications (encoder rates higher than 1 megahertz) the +5 volt pull-up section may be necessary.

Line Driver Encoders:

When using line driver (or balanced pair) encoders, the corresponding resistor pack should be removed from it's socket. Leaving the resistor pack in the socket can cause faulty encoder operation and possibly severe encoder damage. Optionally, the resistor pack can be replaced with an 8-pin isolated resistor pack to supply termination resistance for the balanced signal pairs.

Pull-up Selection:

The following table lists the pull-up jumper settings for each encoder:

 **WARNING**
Wiring a line driver encoder with the pull-up selected to +12 volts will permanently damage the encoder.

Encoder Pull-Up Jumpers				
Encoder	Resistor	Jumper	+5V	+12V
0	RP2	J1	1-2	2-3
1	RP1	J2	1-2	2-3
2	RP4	J3	1-2	2-3
3	RP3	J4	1-2	2-3

Table 1.3 ACR2000 Encoder Pull-Up Jumpers

Refer to Figure 1 for jumper location.

ACR2000 MOTHERBOARD JUMPERS

Digital Input Reference Select (J5)

This jumper selects the reference voltage to be used for the optically-isolated inputs. The reference voltage selected applies to all inputs; there are no combinations available.

Isolated voltage (VEXT) refers to +24VDC.

WARNING

Wiring VEXT with the incorrect voltage will permanently damage the Digital I/O circuitry. The isolated voltage (VEXT) is selected as +24VDC.

Refer to Figure 1 for jumper location.

Digital Input Reference Jumper			
Input Type	Reference Voltage	J5	User Supplies
Sinking	Reference Inputs to Isolated +24VDC Voltage (VEXT)	1-2	Path to GEXT
Sourcing	Reference Inputs to Isolated Common (GEXT)	2-3	Path to +24VDC (VEXT)

Table 1.4 ACR2000 Digital Input Reference Jumper

ACR2000 MOTHERBOARD JUMPERS



USER CIRCUIT	JUMPER POSITION
<p>Sink Input</p> 	<p>J5-1 to J5-2</p>
<p>Source Input</p> <p>+24VDC Isolated Voltage (VEXT)</p> 	<p>J5-2 to J5-3</p>

Figure 2. ACR2000 Digital Input User Circuit

ACR2000 MOTHERBOARD JUMPERS

Digital Output Sink/Source Select Jumpers (J7 and J8)

These jumpers are set at the factory based on the type of the output drivers, IC's U14 and U15. The selected type of the output driver applies to all outputs; there are no combinations available.

Isolated voltage (VEXT) refers to +24VDC.

WARNING

Wiring VEXT with the incorrect voltage will permanently damage the Digital I/O circuitry. The isolated voltage (VEXT) is +24VDC.

Selecting the wrong jumper settings for the type of output drivers installed on the board will permanently damage the output driver IC's (U14 and U15). The output drivers are installed at the factory, based on the Sinking or Sourcing Option selected when ordering the board.

Refer to Figure 1 for jumper location.

Digital Output Sink/Source Select Jumpers				
Output Type	Output Driver IC Type Installed (U14/U15) (See Warning Above)	J7	J8	User Supplies
Sink	Motorola / ST Micro ULN2803A	1-2	1-2	Path to VEXT
Source	Allegro UDN2981A	2-3	2-3	Path to GEXT

Table 1.5 ACR2000 Digital Output Sink/Source Select Jumper

ACR2000 MOTHERBOARD JUMPERS

USER CIRCUIT	JUMPER POSITIONS
<p>Sink Output +24VDC Isolated Voltage (VEXT)</p>  <p>From ACR2000</p>	<p>J7-1 to J7-2 J8-1 to J8-2</p>
<p>Source Output</p>  <p>From ACR2000</p> <p>GEXT (Isolated Common)</p>	<p>J7-2 to J7-3 J8-2 to J8-3</p>

Figure 3. ACR2000 Digital Output User Circuit

ACR2000 MOTHERBOARD JUMPERS

EPROM Size Select Jumpers (J9 and J12)

These jumpers are set at the factory to match the EPROM size required for the current firmware version. These jumpers should not be set by the user.

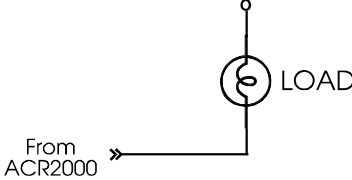
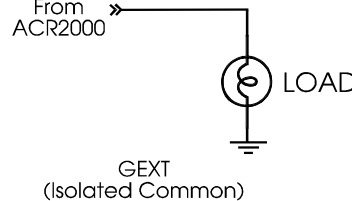
EPROM Size Jumpers			
Memory	Part No.	J9	J12
128K x 32	27C2048	1-2	2-3
256K x 32	27C4096	2-3	2-3

Table 1.6 ACR2000 EPROM Size Select Jumpers

Refer to Figure 1 for jumper location.

ACR2000 MOTHERBOARD JUMPERS

Battery Back-Up Select Jumpers (J10 and J11)

These two jumpers allow for disabling and enabling of the battery back-up when a ACRCOMM communications module is present.

When an ACRCOMM module is present and the jumpers are set to “Battery Function Enabled”, user programs on the board are retained when power is removed. When an ACRCOMM module is present and the jumpers are set to “Battery Function Disabled”, user programs on the board are not retained when power is removed.

When no ACRCOMM module is present, the jumpers must be set to “Battery Function Disabled” position for ACR2000 to function.

Battery Back-up Jumpers		
Battery Function	J10	J11
Battery Function Disabled	1-2	1-2
Battery Function Enabled	2-3	2-3

Table 1.7 ACR2000 Battery Back-Up Enable Jumpers

Refer to Figure 1 for jumper location.

ACR2000 MOTHERBOARD JUMPERS

Interrupt Select Jumper (J13)

The ACR2000 can be instructed to interrupt a PC host through the parallel bus by issuing a SET 112 command in immediate mode or from within a program. Interrupt driven software at the host level is an advanced topic and should only be attempted by someone with a thorough knowledge of interrupt driven code.

In order for the PC to see the interrupt, the proper jumper selection from the following table must be made. IRQ5 is usually a good choice since printer code seldom uses interrupts and use of the secondary printer port (LPT2) is even rarer.

Level	J13	Common Function
Disabled	1-3*	Not Applicable
IRQ3	1-2	Secondary Serial (COM2)
IRQ4	3-4	Primary Serial (COM1)
IRQ5	5-6	Secondary Parallel (LPT2)
IRQ7	7-8	Primary Parallel (LPT1)
IRQ10	9-10	Reserved (unused)
IRQ11	11-12	Reserved (unused)
IRQ12	13-14	Reserved (unused)
IRQ15	15-16	Reserved (unused)

Table 1.8 ACR2000 PC BUS Interrupt Select Jumpers

Refer to Figure 1 for jumper location.

IMPORTANT NOTE:

When the ACR2000 is used in a Pentium™ processor based PCI motherboard, the selected interrupt must be configured in the PCI motherboard BIOS as a Legacy ISA interrupt (or Used By ISA in some BIOS'), since the ACR2000 is an ISA board.

ACR2000 MOTHERBOARD HARDWARE WIRING

This section contains diagrams of the connectors on the ACR2000 motherboard.

Before optically-isolated digital inputs and outputs can be used, the card must be connected to an external +24V DC power supply. This connection is made at the PWR1 connector and is fused on-board at 2 amps to protect the controller card.

WARNING

Wiring VEXT with the incorrect voltage will permanently damage the Digital I/O circuitry. The isolated voltage (VEXT) is +24VDC.

ACR2000 MOTHERBOARD HARDWARE WIRING

Encoder Inputs (P1)

There is one 34 pin header provided on the ACR2000 for encoder feedback. The 34 pin header provides up to four (4) axes of encoder feedback. Refer to Figure 1 for connector location.

Note: P1 is a 34-pin shrouded male header.

P1			
Usage	Pin	Usage	Pin
CHA0	1	CHA0'	2
CHB0	3	CHB0'	4
MRK0	5	MRK0'	6
VCC	7	GND	8
CHA1	9	CHA1'	10
CHB1	11	CHB1'	12
MRK1	13	MRK1'	14
VCC	15	GND	16
CHA2	17	CHA2'	18
CHB2	19	CHB2'	20
MRK2	21	MRK2'	22
VCC	23	GND	24
CHA3	25	CHA3'	26
CHB3	27	CHB3'	28
MRK3	29	MRK3'	30
VCC	31	GND	32
N/C	33	N/C	34

Table 1.9 ACR2000 Encoder Input Connector

ACR2000 MOTHERBOARD HARDWARE WIRING

Encoder Inputs (P1), Continued

The ACR2000 can accept any feedback device that supplies either a +5V or +12V differential signal to the ACR2000. The most common type of device is a differential encoder. Refer to the table below for common encoder setups.

Encoder Type	ACR2000 Pull-up/Jumper Setting	Length of Cable/Type
Differential Line Driver (+5 Volt Outputs)	Remove Pull-ups	100 ft. (Beldon 9330 Shielded Twisted Pair)
Open Collector Driver (No Pull-ups on Encoder)	Install Pull-ups and Jumper to +12V	75 ft. (Beldon 9330 Shielded Twisted Pair)
Open Collector Driver (With Pull-ups to +5 V on Encoder)	Install Pull-ups and Jumper to +5V	50 ft. (Beldon 9330 Shielded Twisted Pair)
TTL Driver (+5 Volt Outputs)	Remove Pull-ups	50 ft. (Beldon 9330 Shielded Twisted Pair)

When using a single-ended encoder (an encoder without the A-, B-, or Z- outputs), additional pull-ups and pull-down resistors must be added externally to the ACR2000 board in order for the ACR2000 to read the encoder signals. **Warning:** This is not a recommended mode of operation. Noise immunity is significantly reduced.

Refer to the ACR2000 Typical Connection Diagram section of this manual for details on wiring a single-sided encoder to the ACR2000.

ACR2000 MOTHERBOARD HARDWARE WIRING

Analog Input/Output (P2)

The analog input/output connections are made through a 44-pin D-style connector on the side of the ACR2000 motion controller. Refer to Figure 1 for connector location.

P2 is a high density type HDP22 right-angle receptacle connector, AMP part number 748482-5.

A user hardware interface kit is provided with each board as follows:

1. Mating Connector Plug. AMCS P/N CN333 (AMP P/N 748366-1)
2. Crimp Snap-In Pin Contacts. AMCS P/N CN033 (AMP P/N 748333-7)
3. Strain Relief. AMCS P/N CN045 (AMP P/N 748678-3)

NOTE: Hand tool AMP P/N 90430-1 is required for the above crimp contacts.

P2					
Usage	Pin	Usage	Pin	Usage	Pin
WD-NO	1	WD-COM	16	WD-NC	31
SVCC	2	SVCC	17	SVCC	32
ASIG-0/STEP-0	3	AGND-0/DIR-0	18	MISC-0/LCUR-0	33
ASIG-1/STEP-1	4	AGND-1/DIR-1	19	MISC-1/LCUR-1	34
SVCC	5	SVCC	20	SVCC	35
ASIG-2/STEP-2	6	AGND-2/DIR-2	21	MISC-2/LCUR-2	36
ASIG-3/STEP-3	7	AGND-3/DIR-3	22	MISC-3/LCUR-3	37
N/C	8	N/C	23	N/C	38
N/C	9	N/C	24	N/C	39
N/C	10	N/C	25	N/C	40
AIN-0	11	AIN-COM	26	AIN-4	41
AIN-1	12	AIN-COM	27	AIN-5	42
AIN-2	13	AIN-COM	28	AIN-6	43
AIN-3	14	AIN-COM	29	AIN-7	44
N/C	15	N/C	30		

Table 1.10 ACR2000 Analog I/O Connector

ACR2000 MOTHERBOARD HARDWARE WIRING

Analog Input/Output (P2), continued

A fused +5VDC Stepper Output (SVCC) is available on the P2 connector for use with wiring the Stepper SIMM Module outputs. The maximum recommended output rating for SVCC is 250 milliamps.

See Figure 1 for fuse F2 location.

Stepper +5VDC Output Fuse			
Fuse	Circuit	Amps	Littelfuse Part No.
F2	SVCC	0.500	154.500

Table 1.11 ACR2000 Isolated Power Fuses

ACR2000 MOTHERBOARD HARDWARE WIRING

Digital Inputs / Outputs (P3)

There is one 34 pin header provided on the ACR2000 for digital I/O interface. The 34 pin header is used for both the 16 Digital Inputs and 16 Digital Outputs. Refer to Figure 1 for connector location.

Note: P3 is a 34-pin shrouded male header.

P3			
Usage	Pin	Usage	Pin
INP-00	1	INP-01	2
INP-02	3	INP-03	4
INP-04	5	INP-05	6
INP-06	7	INP-07	8
INP-08	9	INP-09	10
INP-10	11	INP-11	12
INP-12	13	INP-13	14
INP-14	15	INP-15	16
N/C	17	OUT-32	18
OUT-33	19	OUT-34	20
OUT-35	21	OUT-36	22
OUT-37	23	OUT-38	24
OUT-39	25	OUT-40	26
OUT-41	27	OUT-42	28
OUT-43	29	OUT-44	30
OUT-45	31	OUT-46	32
OUT-47	33	N/C	34

Table 1.12 ACR2000 Digital I/O Connector

ACR2000 MOTHERBOARD HARDWARE WIRING

Digital I/O Power (PWR1)

PWR1 is the connection for the user supplied voltage for the Digital Inputs and Digital Outputs and should be wired to VEXT as shown in the table below. Refer to Figure 1 for connector location.

Isolated voltage (VEXT) refers to +24VDC.

Note: PWR1 is a 4-pin male Weidmuller plug.

PWR1 Isolated Power Connector	
Usage	Pin
Isolated Common (GEXT)	1
Isolated Common (GEXT)	2
+24VDC Isolated Voltage (VEXT)	3
+24VDC Isolated Voltage (VEXT)	4

Table 1.13 ACR2000 Isolated Power Connector

Isolated Power Fuse			
Fuse	Circuit	Amps	Littelfuse Part No.
F1	VEXT	2	154.002

Table 1.14 ACR2000 Isolated Power Fuses

CHAPTER 2

ACRCOMM MODULE HARDWARE SETUP (OPTIONAL)

CHAPTER 2 OVERVIEW

The ACRCOMM Plug-In Module provides stand-alone operation capability for the ACR2000 motherboard. ACRCOMM functions include external power input, User-SRAM battery back-up capability, and communication ports (2 serial, 1 parallel).

This section contains diagrams of the jumpers and switches on the ACRCOMM module.

Factory default jumper settings for the ACRCOMM module are highlighted within the following jumper tables.

ACRCOMM SERIAL COMMUNICATIONS

The ACR2000 serial communication interface is software configurable. At power-up, the default COM1/COM2 communications mode is RS-232.

ACR2000/SA Boards:

For Standalone ACR2000 boards, reconfiguration of the communications ports to RS-422 must be performed via an RS-232 port.

If one of the serial ports is a dedicated RS-232 port, reconfiguration of the second port may be accomplished at power-up (or at any time).

If both ports are to be configured to RS-422 mode, the following must be performed:

1. Open serial communication to one of the ports via RS-232.
2. Load a PBOOT program containing the desired communication flags configuration for COM1 and COM2 ports.

This will configure the serial ports to the desired mode of operation at power-up. If a different communication mode is then required, disabling the User-Memory battery-backup batteries via jumpers or a issuing a BRESET command (or issuing a FLASH ERASE command, if the programs are stored in flash memory) will set the communications modes back to default (RS-232) at the next power-up sequence.

ACR2000/PS Boards:

For PC ACR2000 boards with the communications option, the serial ports may be configured as above via a serial port, or at power-up (or any time) via the ISA bus communications port.

ACRCOMM SERIAL COMMUNICATIONS, continued

The following tables show the configuration schemes for the ACR2000 board with the serial communication ACRCOMM module option. Refer to the User's Guide manual, COM1/COM2 Stream Flags, Appendix B, for bit flag details.

MUX Flags, Set-up communication type flags:

MUX1 FLAG	MUX0 FLAG	COMM FUNCTION
CLR (0)	CLR (0)	Not Used
CLR (0)	SET (1)	RS-232 (Default)
SET (1)	CLR (0)	RS-422
SET (1)	SET (1)	Not Used

RECEIVE/TRANSMIT Flags, RS-422 flow control flags:

RECEIVE FLAG	TRANSMIT FLAG	COMM FUNCTION
CLR (0)	CLR (0)	Not Used (Default)
CLR (0)	SET (1)	Use for RS-422 Operation: Full Duplex Receiver Enabled Transmitter Enabled
CLR (0)	CLR (0)	Not Used
CLR (0)	SET (1)	Not Used
SET (1)	Don't Care	Not Used

RS-422 INTERFACE SCHEMATIC

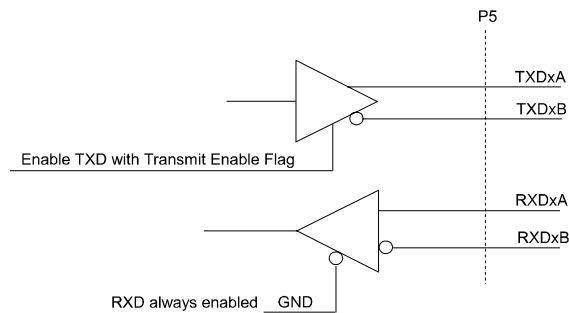
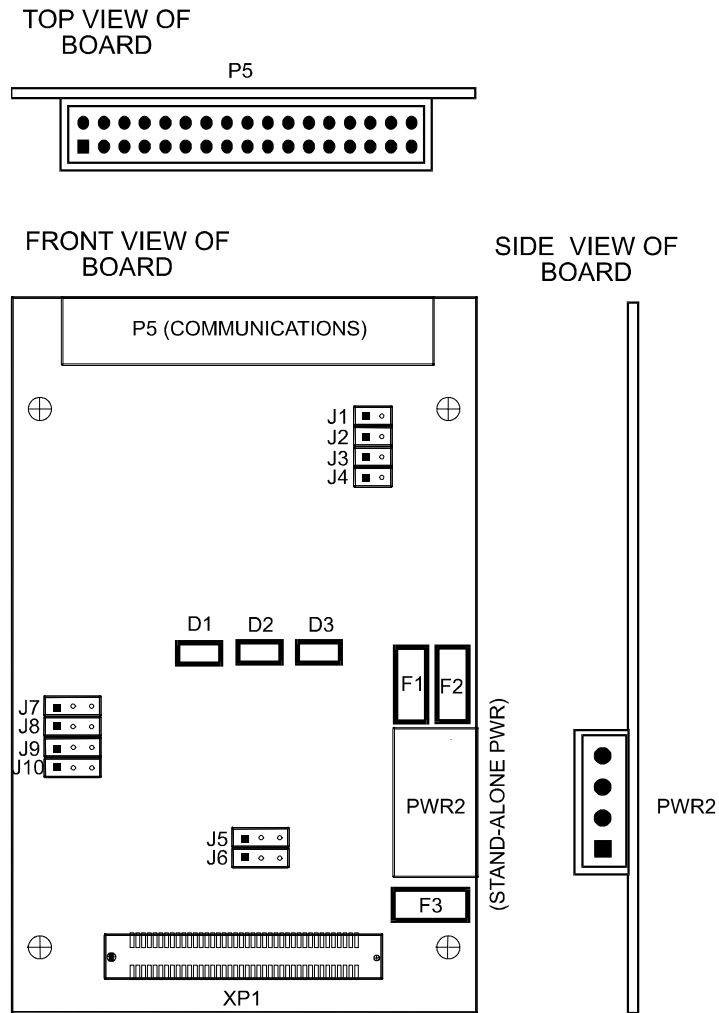

Figure 4. ACRCOMM RS-422 Interface Schematic

ACRCOMM MODULE HARDWARE SETUP (OPTIONAL)



NOTE: Square pin indicates Pin 1.

Figure 5. ACRCOMM Module Outline

ACRCOMM MODULE JUMPERS

Jumper Table List

The following is a list of the jumper functions on the ACRCOMM module:

JUMPER	JUMPER FUNCTION
J1	COM1 RS-422 Termination Resistor Select (Page 29)
J2	COM1 RS-422 Termination Resistor Select (Page 29)
J3	COM2 RS-422 Termination Resistor Select (Page 29)
J4	COM2 RS-422 Termination Resistor Select (Page 29)
J5	Battery BT2 Enable/Disable (Page 30)
J6	Battery BT1 Enable/Disable (Page 30)
J7	COM1 and COM2 Autobaud Detect Enable (Page 31)
J8	Reserved
J9	Reserved
J10	Reserved

ACRCOMM MODULE JUMPERS (OPTIONAL)

RS-422 Communication Ports Line Terminator Jumpers (J1 thru J4)

These jumpers provide termination resistors for the RS-422 signals.

Communication Ports Termination Jumpers			
Signal	Jumper	Termination	No Termination
RXD1A/RXD1B	J1	Jumper In	Jumper Out
TXD1A/TXD1B	J2	Jumper In	Jumper Out
RXD2A/RXD2B	J3	Jumper In	Jumper Out
TXD2A/TXD2B	J4	Jumper In	Jumper Out

Table 2.1 ACRCOMM RS-422 Termination Jumpers

Refer to Figure 4 for jumper location.

ACRCOMM MODULE JUMPERS (OPTIONAL)

Battery Enable Jumpers (J5 and J6)

These two jumpers enable or disable the batteries on the ACRCOMM module. A primary 1000mA-Hr Lithium (LI) coin battery is provided on the module (BT1 – located on front of board – user-replaceable). A 50mA-Hr rechargeable Vanadium-Lithium (VA-LI) battery is also provided as a short-term secondary back-up source (BT2 – located on back of board – factory replaceable only). This allows for continued back-up of the user memory during replacement of the primary battery.

The factory default jumper settings are set to disconnect the batteries from the circuit. This prevents the battery power from draining during shipping. The jumpers must be moved to the Battery Load Enable positions for normal battery back-up operation.

Battery Selection Jumpers		
Battery Type/Function	J5	J6
Battery Load Enable (BT1 and BT2 installed)	1-2	1-2
Battery Load Enable (BT1 only installed)	2-3	1-2
Battery Load Disable	2-3	2-3

Table 2.2 ACRCOMM Battery Selection Jumpers

Refer to Figure 4 for jumper location.

ACRCOMM MODULE JUMPERS (OPTIONAL)

Autobaud Detect Jumper (J7)

This jumper enables or disables the autobaud detect feature of the serial communications channels on the ACRCOMM module. This jumper works in conjunction with the COM1 Startup Mode (P7013) and COM2 Startup Mode (P7029) parameters listed in the ACR2000/ACR8000 User's Guide under Miscellaneous Parameters P6912-P7029.

When the Startup Enable bit is not set (0 - default) in the COM1/2 Startup Mode parameters, the jumper is ignored and Autobaud detect is always enabled. The default operation of the COM1 and COM2 ports is Autobaud Detect enabled.

When the Startup Enable bit is set (1) in the COM1/2 Startup Mode parameters, the jumper defines the Autobaud Detect function as listed in the following table.

Autobaud Detect Jumper	
Function	J7
Autobaud Detect Enabled	ON
Autobaud Detect Disabled	OFF

Table 2.3 ACRCOMM Autobaud Detect Jumper

Refer to Figure 4 for jumper location.

ACRCOMM MODULE HARDWARE WIRING (OPTIONAL)

This section contains diagrams of the connectors on the ACRCOMM module.

ACRCOMM MODULE HARDWARE WIRING (OPTIONAL)

Standalone Power (PWR2)

PWR2 is the connection on the ACRCOMM communications board for the main power supply when the card is used as a stand-alone board. Power monitor LED's, D1 thru D3, are available for visual confirmation of power applied to board (monitor point is after fuses F1 thru F3). Refer to Figure 4 for connector, fuse, and LED location.

Note: PWR2 is a 4-pin male Weidmuller plug.

PWR2 Stand-alone Power Connector (Power Monitor LED Reference)		
Usage	PWR2 Pin	Power Monitor LED
Stand-alone GND	1	N/A
Stand-alone +5V	2	D2
Stand-alone -12V	3	D3
Stand-alone +12v	4	D1

Table 2.3 ACRCOMM Standalone Power Connector

Stand-alone Power Fuses			
Fuse	Circuit	Amps	Littelfuse Part No.
F3	+5V	4	154.004
F2	-12V	0.25	154.250
F1	+12V	0.25	154.250

Table 2.4 ACRCOMM Standalone Power Fuses

ACRCOMM MODULE HARDWARE WIRING (OPTIONAL)

Communications (P5)

There is one 34 pin header provided on the ACRCOMM communications board for the 2 serial and 1 parallel communications ports. The two serial ports, COM1 and COM2, can be individually configured as RS-232 or RS-422 interfaces. Configuration of the COM ports is software selectable by the user.

The following diagram shows the connections for the 3 communications ports. Refer to Figure 4 for connector location.

Note: P5 is a 34-pin shrouded male header.

P5			
Usage	Pin	Usage	Pin
RXD1	1	TXD1	2
GND	3	MUX1	4
TXD1A	5	TXD1B	6
RXD1A	7	RXD1B	8
RXD2	9	TXD2	10
GND	11	MUX2	12
TXD2A	13	TXD2B	14
RXD2A	15	RXD2B	16
STB	17	AFD	18
ERR	19	INIT	20
SLIN	21	GND	22
PD0	23	PD1	24
PD2	25	PD3	26
PD4	27	PD5	28
PD6	29	PD7	30
ACK	31	BUSY	32
PE	33	SLCT	34

Table 2.5 ACRCOMM Communications Connector

CHAPTER 3

SPECIFICATIONS

ACR2000 SPECIFICATION

ITEM	SPECIFICATION
CPU:	32 Bit Floating Point DSP @ 50 MHz
Processor Type:	Texas Instruments TMS320C32
Board Size:	1 Slot (option modules take up 1 additional slot, each) 7.3" x 4.25" Half-Size PC Form Factor
Axis Configuration:	2 or 4 axes configurations
Weight:	PC Version: 7.5 oz. Stand-alone Version: 10.5 oz.
Operating Temperature:	0°C to 50°C (32°F to 122°F)
Humidity:	0 to 95%, Non-Condensing
Power Consumption:	+5 +/- 0.2 VDC @ 1.5A +12 +/- 0.5 VDC @ 0.15A -12 +/- 0.5 VDC @ 0.15A Note: Power consumption does not include any additional power required for external components (Encoders, Stepper Outputs, etc.).
Encoder Inputs:	Up to 4 per card Differential Quadrature Encoder Open-Collector or Line Driver 0.1 Hz to 8 MHz Frequency Range 100mA maximum power source per channel
DAC/Stepper Outputs:	Up to 4 per card DAC Outputs: +/- 10VDC @ 5mA, maximum Programmable Output (DAC GAIN, DAC OFFSET) 16 Bit Resolution Single Ended input amplifiers can be used if caution is used to avoid ground loops. Stepper Outputs: Open-Collector Step, Direction, and Low Current Outputs (no pull-up resistors on-board); Fused +5VDC Stepper Output available on P2 connector up to 250 mA. Step Output Frequency : 0 to 6 KHz, pulse width 167us 6 KHz to 4 MHz, approx. 50% duty cycle

ACR2000 SPECIFICATION, continued

ITEM	SPECIFICATION
Feedback Types:	Any Differential 5VDC or 12VDC including: <ul style="list-style-type: none">- Quadrature Encoder- Glass Scales- Analog (Optional)
Watchdog Relay:	+24VDC @ 1.0 A Single Pole - Double Throw (SPDT) Hardwire through P2 analog header
External I/O Power Supply Requirements:	+24 VDC (+3/-6VDC) @ 2A
Digital Inputs:	16 Optically Isolated (standard) @ External Voltage Supplied Sinking or Sourcing Available Activates on 10mA per input
Digital Outputs:	16 Optically Isolated (standard) @ External Voltage Supplied Output Loads: 16 Outputs @ 50 mA continuously, each or Up to 6 Outputs @ 125mA continuously, each, distributed across the two (2) output drivers, as follows: <ul style="list-style-type: none">up to 3 between OUT32 and OUT39up to 3 between OUT40 and OUT47 Open Collector Sinking or Sourcing Type Available
A/D Inputs (On-Board Option):	Up to 8 single-ended or up to 4 differential 12 bit resolution Configurable for various analog inputs 9 microsecond conversion time
Communications:	PC-Bus standard COM1, COM2, and LPT available on optional ACRCOMM module Simultaneous communications on all 4 ports
Serial Communications: (ACRCOMM Module)	2 ports standard (COM1, COM2) Software Configurable RS-232 or RS-422 Automatic Baud Detect (300 Hz - 38.4 KHz)

This page intentionally left blank.

CHAPTER 4

ACR2000 MECHANICAL DRAWINGS

ACR2000 MECHANICAL DIMENSIONS

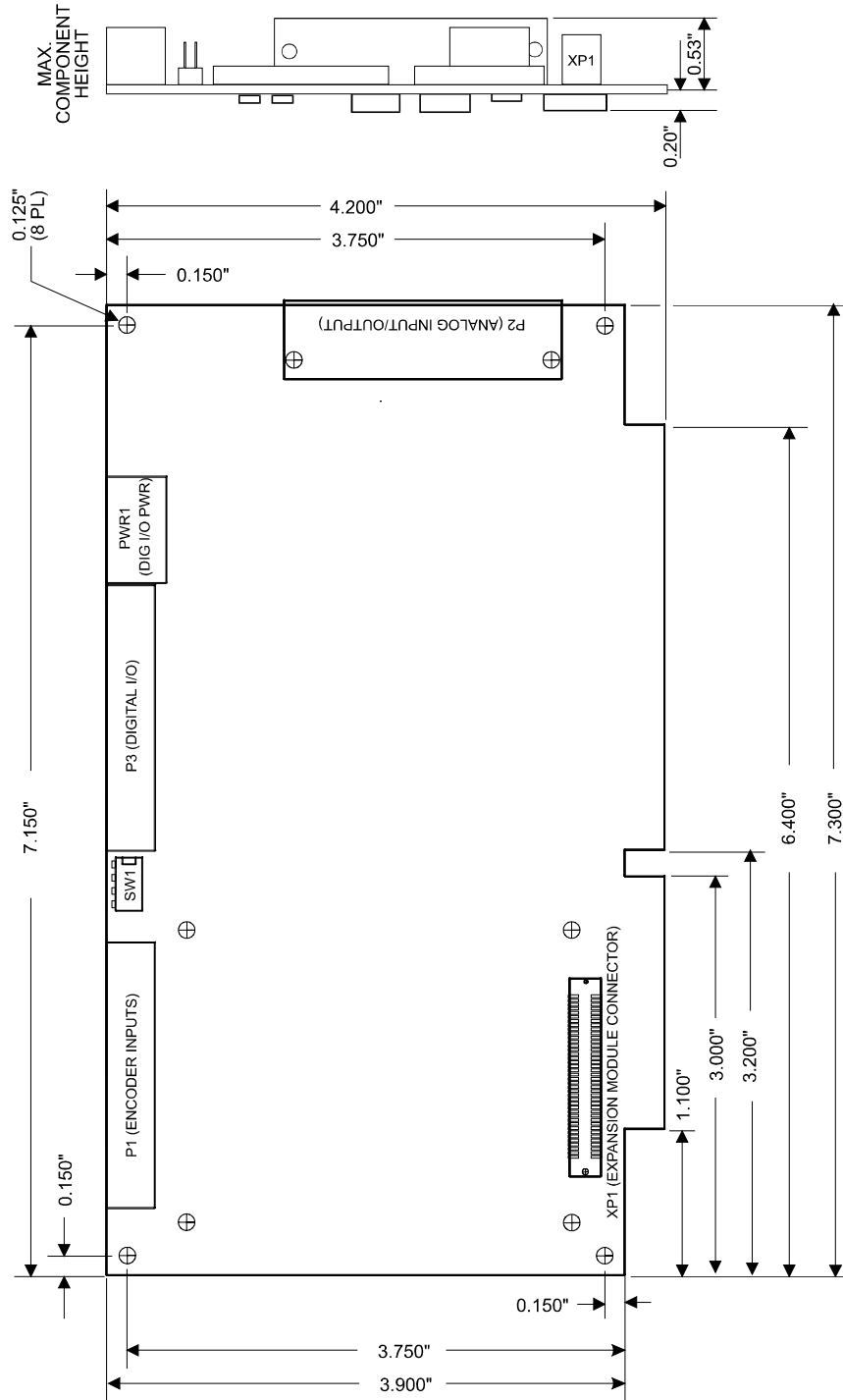

Figure 6. ACR2000 Mechanical Dimensions

ACRCOMM MODULE MECHANICAL DIMENSIONS

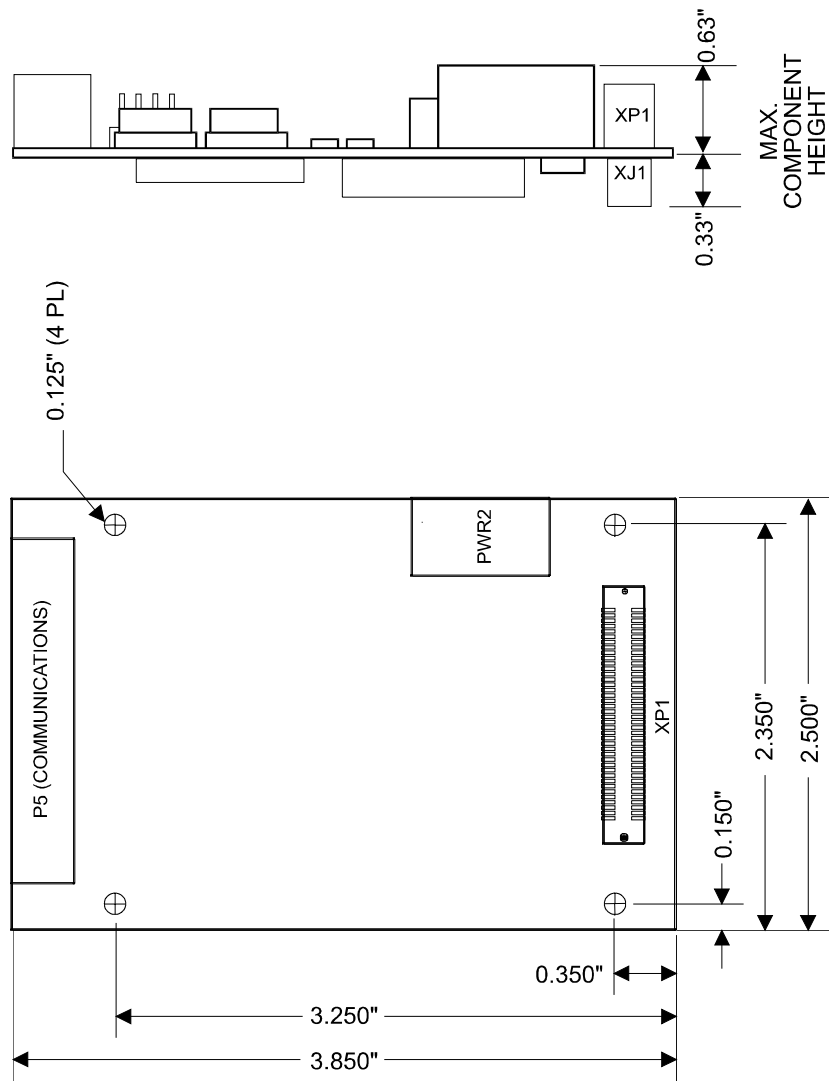

Figure 7. ACRCOMM Mechanical Dimensions

ACR2000 BOARD STACKING EXAMPLES



Figure 8. ACR2000 Board Stacking Mechanical Dimensions Examples

Note: ACRCOMM and ACRIO Modules can be stacked on the ACR2000 Base Board in any order. The above stacking illustration examples are for reference only.

ACR2000 TYPICAL CONNECTION DIAGRAMS

The following schematic sheets represent some typical connection and wiring diagrams for the ACR2000 Motherboard and associated plug-in modules:

For electronic media, refer to the typical connection drawing file, ACR2000 TYPICAL CONNECTIONS.PDF, supplied separately on the AMCS CD P/N CD2000 under the \DOCS directory.



Artisan Technology Group is your source for quality new and certified-used/pre-owned equipment

- FAST SHIPPING AND DELIVERY
- TENS OF THOUSANDS OF IN-STOCK ITEMS
- EQUIPMENT DEMOS
- HUNDREDS OF MANUFACTURERS SUPPORTED
- LEASING/MONTHLY RENTALS
- ITAR CERTIFIED SECURE ASSET SOLUTIONS

SERVICE CENTER REPAIRS

Experienced engineers and technicians on staff at our full-service, in-house repair center

*InstraView*SM REMOTE INSPECTION

Remotely inspect equipment before purchasing with our interactive website at www.instraview.com ↗

WE BUY USED EQUIPMENT

Sell your excess, underutilized, and idle used equipment. We also offer credit for buy-backs and trade-ins. www.artisanng.com/WeBuyEquipment ↗

LOOKING FOR MORE INFORMATION?

Visit us on the web at www.artisanng.com ↗ for more information on price quotations, drivers, technical specifications, manuals, and documentation

Contact us: (888) 88-SOURCE | sales@artisanng.com | www.artisanng.com