



Artisan Technology Group is your source for quality new and certified-used/pre-owned equipment

- FAST SHIPPING AND DELIVERY
- TENS OF THOUSANDS OF IN-STOCK ITEMS
- EQUIPMENT DEMOS
- HUNDREDS OF MANUFACTURERS SUPPORTED
- LEASING/MONTHLY RENTALS
- ITAR CERTIFIED SECURE ASSET SOLUTIONS

SERVICE CENTER REPAIRS

Experienced engineers and technicians on staff at our full-service, in-house repair center

*InstraView*SM REMOTE INSPECTION

Remotely inspect equipment before purchasing with our interactive website at www.instraview.com ↗

WE BUY USED EQUIPMENT

Sell your excess, underutilized, and idle used equipment. We also offer credit for buy-backs and trade-ins. www.artisanng.com/WeBuyEquipment ↗

LOOKING FOR MORE INFORMATION?

Visit us on the web at www.artisanng.com ↗ for more information on price quotations, drivers, technical specifications, manuals, and documentation

Contact us: (888) 88-SOURCE | sales@artisanng.com | www.artisanng.com

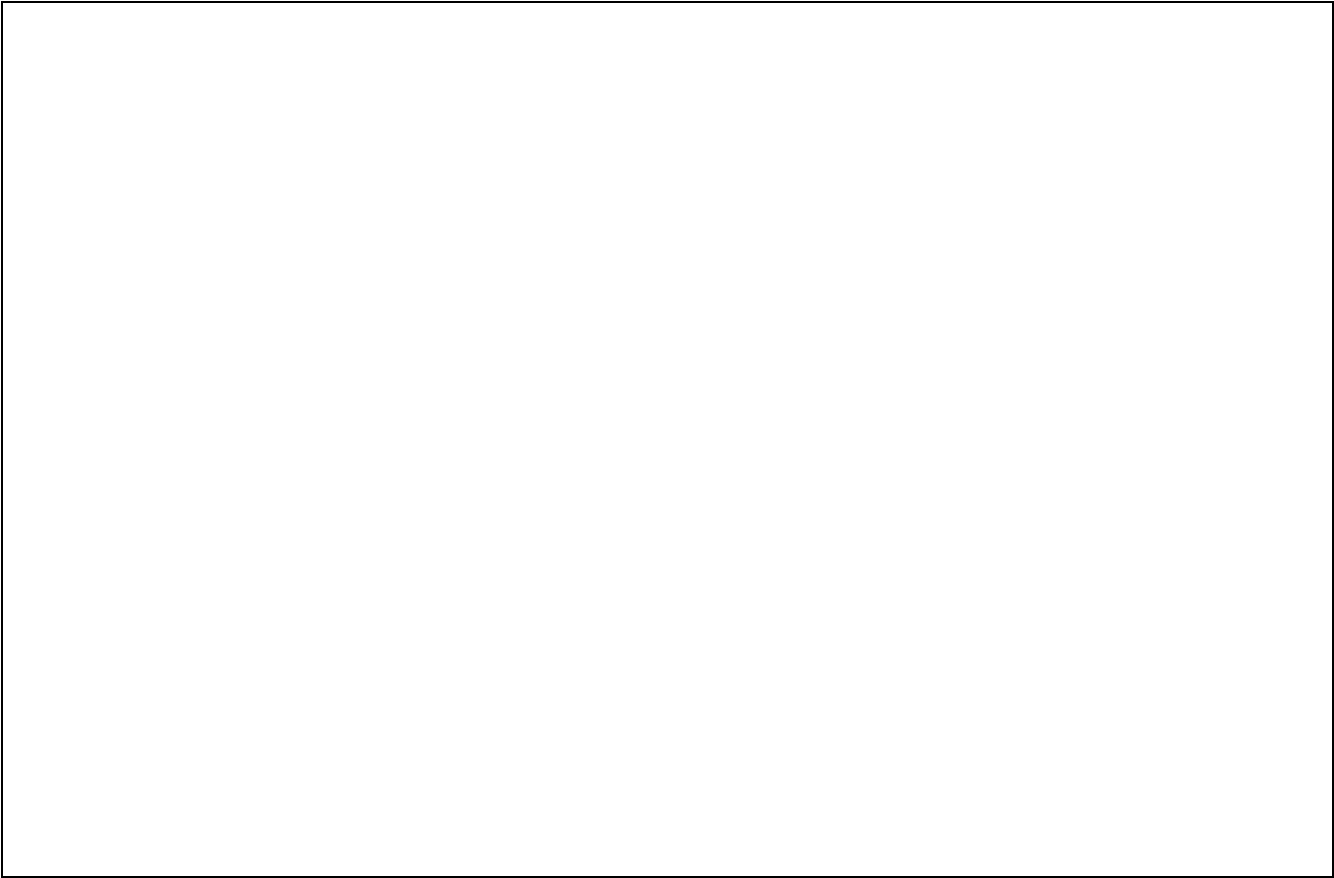

INTERBUS
I/O Unit
RECO12.2
Configuration

SYSTEM200

Title	INTERBUS I/O Unit RECO12.2
Type of document	Configuration
Document code	DOK-CONTRL-RECO12.2***-PR02-EN-P
Internal file reference	<ul style="list-style-type: none"> • DOK-MTC200-TECHN*UNTERL-04M1-EN-P • DOK-MTC200-TEC*DOC*4V3-04M1-EN-P • Drawing number: 120-0400-B306-02
Purpose of the document	<p>This document is used</p> <ul style="list-style-type: none"> • for describing the hardware functions at the RECO12.2 unit • connecting and installing the RECO12.2 unit • providing the Specifications of the RECO12.2 unit

Configuration control

Documentation identification of previous releases	Release date	Comment
DOK-CONTRL-RECO12.2***-PR02-EN-P	02.99	First issue

Copyright

© INDRAMAT GmbH, 1999

Copying this document and giving it to others and the use or communication of the contents thereof without express authority are forbidden. Offenders are liable for the payment of damages. All rights are reserved in the event of the grant of a patent or the registration if a utility model or design. (DIN 34-1)

Validity

All rights are reserved with respect to the content of this documentation and the availability of the product.

Published by

INDRAMAT GmbH • Bgm.-Dr.-Nebel-Str. 2 • D-97816 Lohr a. Main
Phone 09352/40-0 • Tx 689421 • Fax 09352/40-4885

Dept. ECS (RW)

Note

This document is printed on paper bleached without chlorine.

Contents

1 Brief Description and Installation of the RECO12.2 Unit	1-1
1.1 Brief Description.....	1-1
1.2 Overview RECO12.2.....	1-1
1.3 Installation Instructions.....	1-2
Installing the modules	1-2
Mounting dimensions of the RECO12.2 unit.....	1-3
Dimensions of RMB12.2-02 and RMB12.2-04 base racks	1-4
2 Specifications	2-1
2.1 General	2-1
Supply voltage.....	2-1
EMC	2-1
2.2 Addressing	2-1
General information about addressing.....	2-1
Module Addressing of the INDRAMAT SPS	2-2
Address selection for input modules	2-2
Address selection for output modules.....	2-3
3 RMK12.2-IBS-BKL INTERBUS Bus Terminal	3-1
3.1 Brief Description.....	3-1
3.2 Dimensions	3-1
3.3 ID Code:.....	3-2
3.4 Pin Assignments	3-2
Mains Connection and Alarm	3-2
INTERBUS	3-2
Diagnoses	3-3
4 RME12.2-16-DC024 INTERBUS Input Module	4-1
4.1 Brief Description.....	4-1
4.2 Dimensions	4-1
4.3 Pin Assignments	4-2
4.4 Addressing	4-2
5 RME12.2-32-DC024 INTERBUS Input Module	5-1
5.1 Brief Description.....	5-1
5.2 Dimensions	5-1
5.3 Pin Assignments	5-2
5.4 Addressing	5-2

6 RME12.2-16-AC115 INTERBUS Input Module	6-1
6.1 Brief Description.....	6-1
6.2 Dimensions	6-1
6.3 Pin Assignments	6-2
6.4 Addressing	6-2
7 RMA12.2-16-DC024-200 INTERBUS Output Module	7-1
7.1 Brief Description.....	7-1
7.2 Dimensions	7-1
7.3 Pin Assignments	7-2
7.4 Addressing	7-2
8 RMA12.2-32-DC024-050 INTERBUS Output Module	8-1
8.1 Brief Description.....	8-1
8.2 Dimensions	8-1
8.3 Pin Assignments	8-2
8.4 Addressing	8-2
9 RMA12.2-16-AC230-200 INTERBUS Output Module	9-1
9.1 Brief Description.....	9-1
9.2 Dimensions	9-1
9.3 Pin Assignments	9-2
9.4 Addressing	9-2
10 RMA12.2-16-RE230-200 INTERBUS Output Module	10-1
10.1 Brief Description.....	10-1
10.2 Dimensions	10-1
10.3 Load rating curve of the outputs	10-2
10.4 Pin Assignments	10-2
10.5 Addressing	10-3
11 RMC12.2-2E-1A INTERBUS Analog Module	11-1
11.1 General	11-1
11.2 Dimensions	11-2
11.3 Analog Value Inputs X1 and X2	11-3
11.4 Entering the Analog Values.....	11-3
11.5 Current Measurement.....	11-4
11.6 Analog Value Output X3.....	11-4
11.7 Programming the Input Measuring Ranges	11-5
11.8 Structure of the IN/OUT Registers in the INTERBUS.....	11-5
11.9 Addressing	11-5
11.10 Diagnosis Indicators.....	11-6
11.11 Connector Pin Assignments.....	11-6
11.12 Typical Applications	11-7
±10V voltage output	11-7
±10V voltage measurement ($R_{in} > 1M\Omega$)	11-7

0 - 20mA current output	11-8
0 - 20mA current measurement	11-8
temperature measurement using Pt100 element.....	11-8
12 RECO12.2 Configuration Limits	12-1
12.1 General	12-1
12.2 Configuration-Related Current Consumption of the Bus Coupler Unit.....	12-1
13 Accessories	13-1
13.1 Cables and Connectors	13-1
13.2 Additional Annotation	13-2
14 Figures	14-1

1 Brief Description and Installation of the RECO12.2 Unit

1.1 Brief Description

RECO12.2 is a remote I/O station with an INTERBUS field bus interface.

A unit consists of one/several RMB12.2-04 (4 slots) or RMB12.2-02 (2 slots) base racks, a bus coupler module RMK12.2-IBS-BKL, and up to 15 I/O modules. An expansion to 16 module locations is possible by installing four RMB12.2-04 base racks side by side. Local bus communication between the individual I/O modules and the bus coupler module takes place via the bus board in the racks.

The RMK12.2-IBS-BKL bus coupling module with an INTERBUS interface is available for the communication with the controller.

These bus coupling modules are INTERBUS remote bus devices. The associated I/O modules are INTERBUS I/O bus devices. This architecture ensures that each module is addressed as a separate device in the INTERBUS system (transparency).

The INTERBUS permits wide distances within the system to be covered. An INTERBUS ring can be as long as 12.8 km (from the interface module up to the last connected remote bus device). The wide distance of 12.8 km is achieved by subdividing the remote bus into bus segments of up to 400 m each.

Using the RMB12.2-02 or RMB12.2-04 base racks, the bus coupling module in IP20 rating and the I/O modules can indirectly be attached to a 35-mm DIN rail.

1.2 Overview RECO12.2

Designation	Type	Explanation	Material no.
Base rack, 2 slots	RMB12.2-02	accommodates up to 2 modules	278 843
Base rack, 4 slots	RMB12.2-04	accommodates up to 4 modules	278 844
Communication module	RMK12.2-IBS-BKL	INTERBUS interface (bus coupling module)	280 941
Input module	RME12.2-16-DC024	2 x 8 inputs, 24 VDC	280 943
Input module	RME12.2-32-DC024	4 x 8 inputs, 24 VDC	280 939
Input module	RME12.2-16-AC115	2 x 8 inputs, 115 VAC	280 942
Output module	RMA12.2-16-DC024-200	2 x 8 outputs, 24 VDC, 2 A	280 934
Output module	RMA12.2-32-DC024-050	4 x 8 outputs, 24 VDC, 500 mA	280 935
Output module	RMA12.2-16-AC230-200	2 x 8 outputs, 230 VAC, 2A	280 933
Output module	RMA12.2-16-RE230-200	2 x 8 relay outputs, 230 V, 2 A	280 932
Analog module	RMC12.2-2E-1A	Analog module 2 x input, 1 x output	280 944

Figure 1-1: Brief overview of RECO12.2

1.3 Installation Instructions

Chiefly, the RMB12.2-04 or RMB12.2-02 racks are latched onto a TS 35x27x15 DIN rail, and secured with a screw (see RECO 12.2 mounting dimensions).

If necessary, the racks can be mounted directly on the mounting plate in the switchgear cabinet, using the holes provided in the racks (see base rack dimensions).

Installing the modules

Beginning with the bus coupling unit and in slot 1 (left-hand side), the modules are plugged into the base rack. Each module is secured with two retaining screws. The I/O modules are installed side by side to the right of the bus coupling unit in the slots 2 through 16. There must be no gaps between the modules.

Caution: Prior to commissioning you must tighten the retaining screws of the base racks and modules. (Figure 1-5: RMB12.2-04 base rack)

Never insert or disconnect a connector or module while power is applied to the unit.

Mounting dimensions of the RECO12.2 unit

- Installing on DIN rail and fixing
- Mounting dimensions **without** mating connector

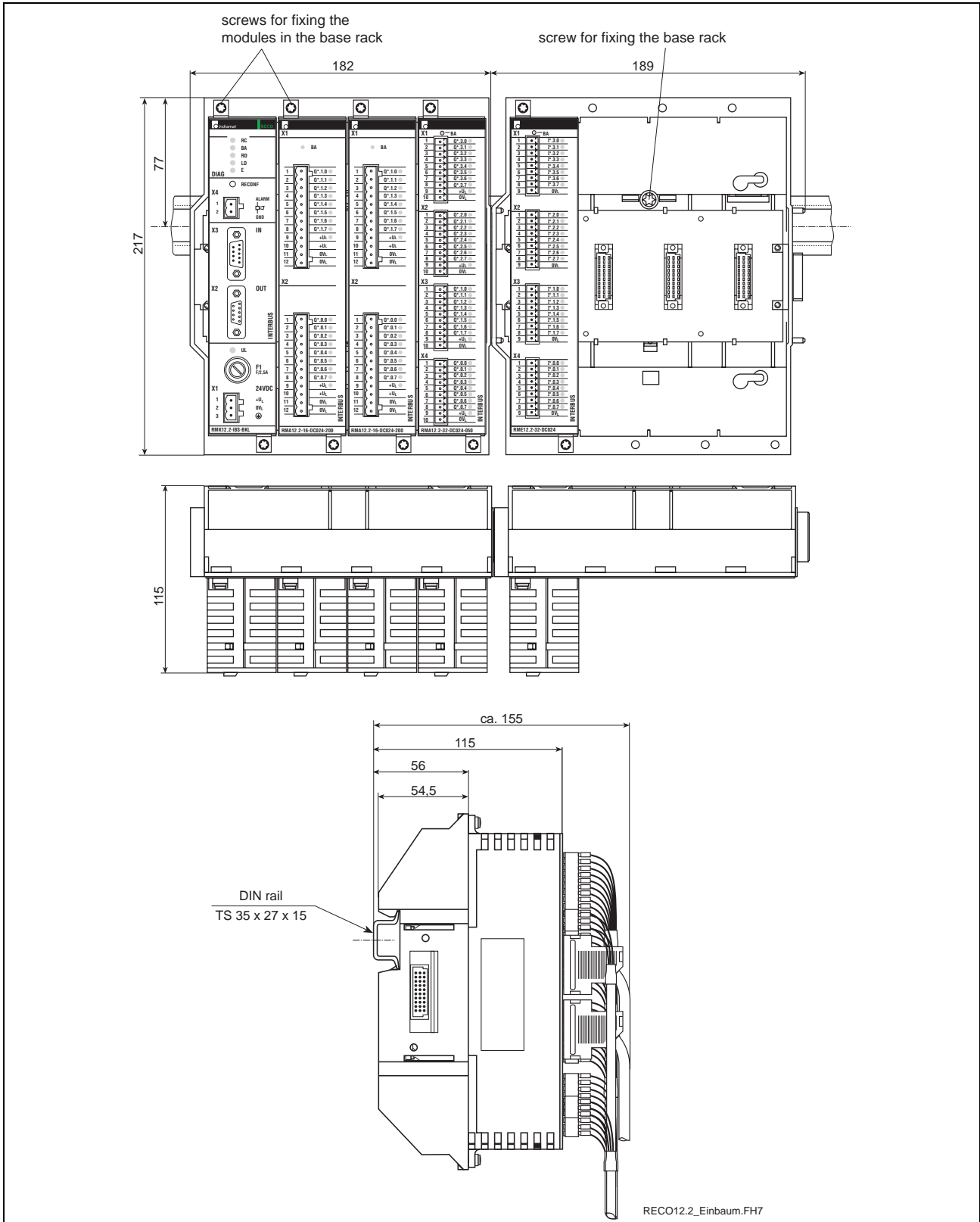

Figure 1-2: Mounting dimensions of the RECO12.2 unit

Dimensions of RMB12.2-02 and RMB12.2-04 base racks

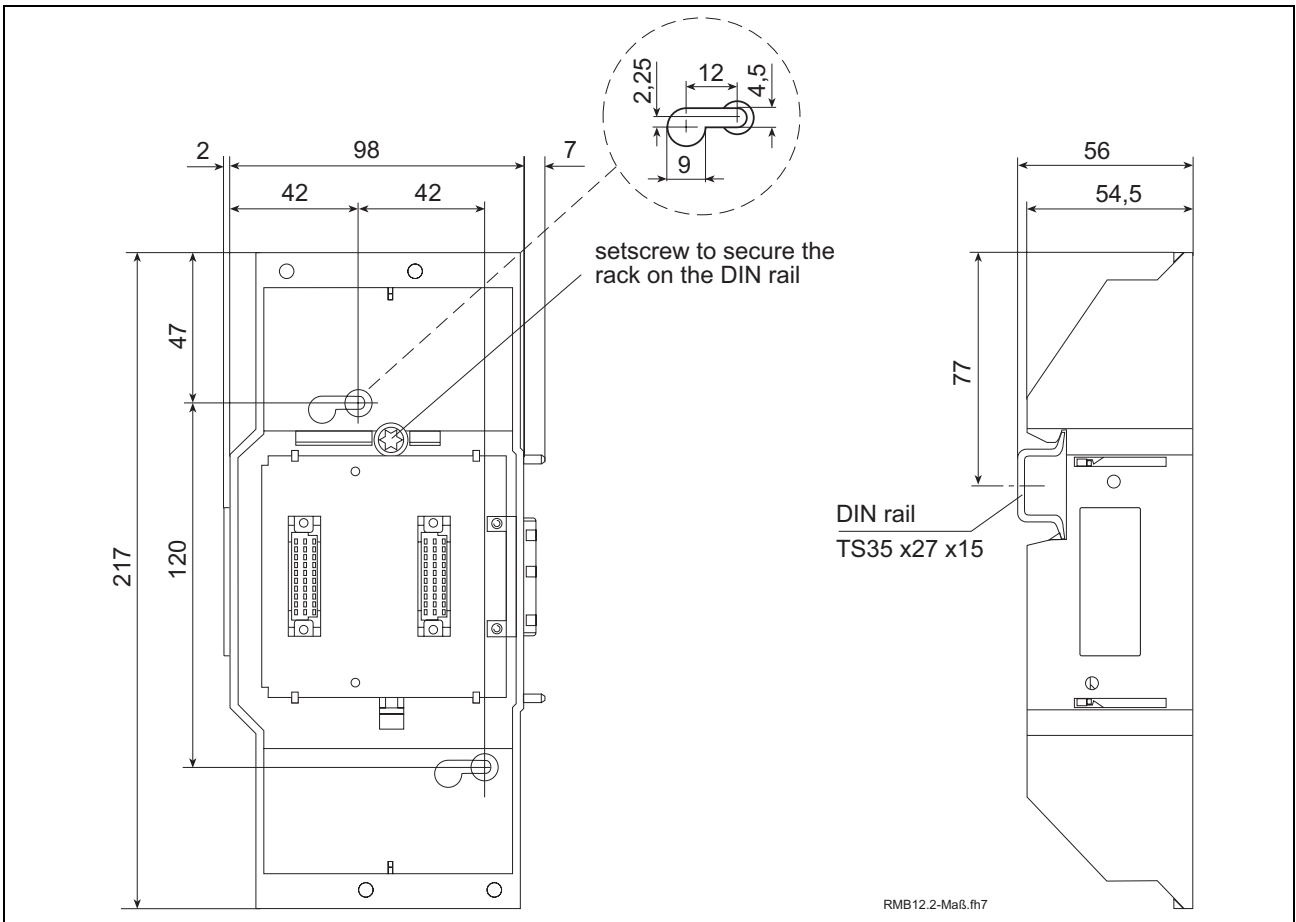

Figure 1-3: RMB12.2-02 base rack

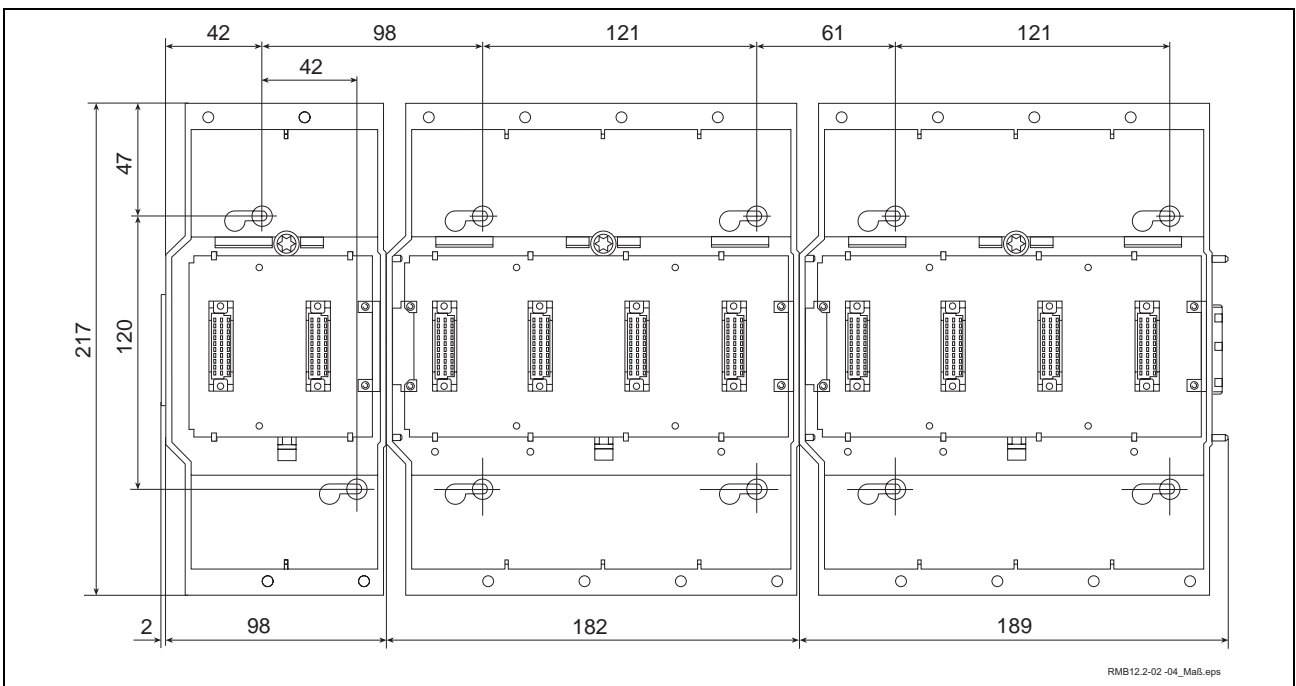

Figure 1-4: RMB12.2-02 base rack in connection with RMB12.2-04

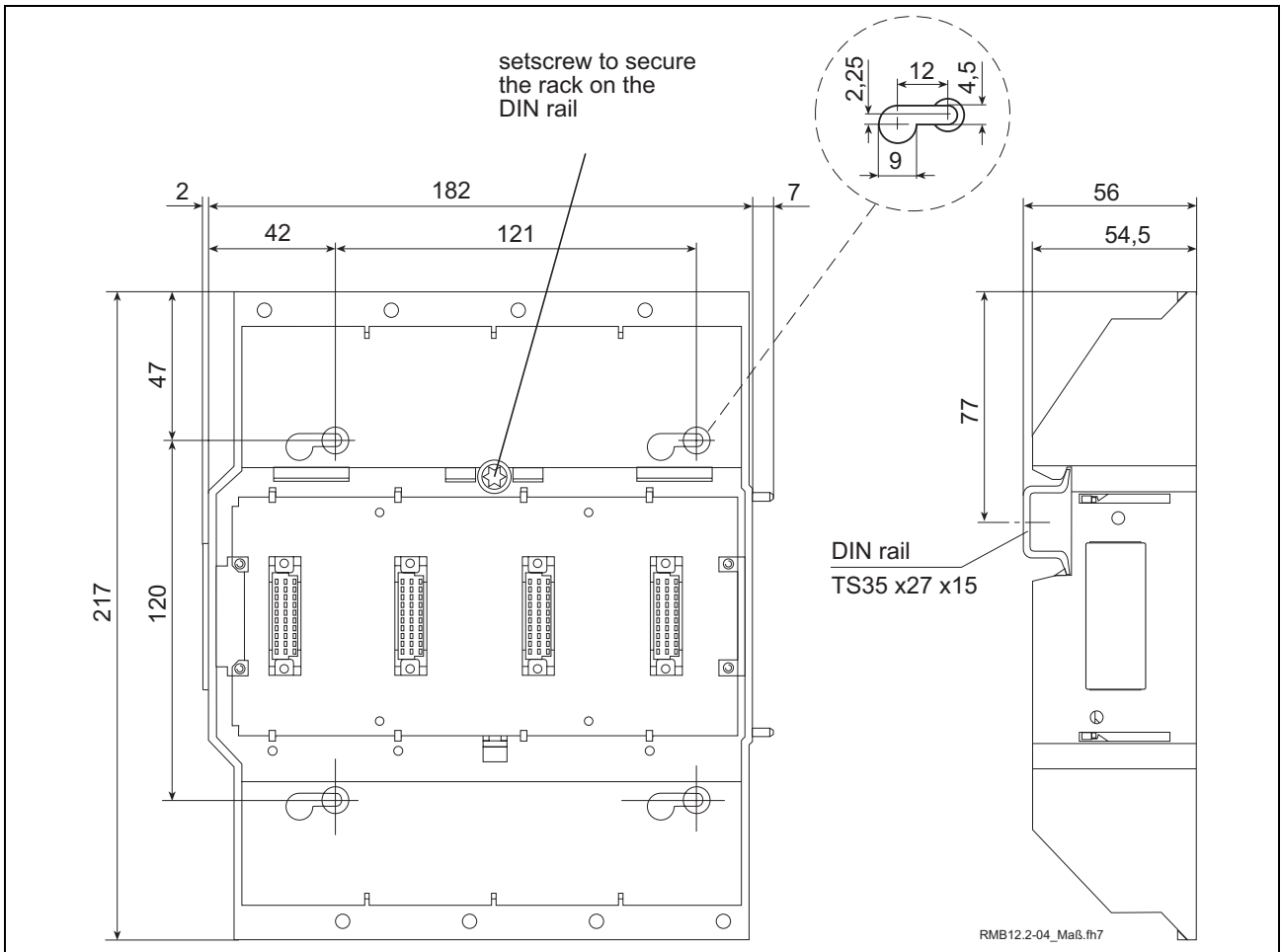

Figure 1-5: RMB12.2-04 base rack

2 Specifications

2.1 General

Permissible cable cross-section for the supply voltage:	Up to 2.5 mm ²
Mounting in the switchgear cabinet:	Using RMB12.2 racks on TS 35 x 27 x 15 DIN rail
Protection rating:	IP 20, DIN VDE 0470, EN 60529
Humidity (storage/transport):	75%, no condensation 85%, no condensation (occasional) DIN 40 040 Class F
Atmospheric pressure:	860 ... 1080 hPa, 1500m (operation) 660 ... 1080 hPa, 3500m (storage)
Operating temperature:	0°C ... 50°C, DIN 40 040 Class KV
Storage temperature:	-30°C ... +85°C

Supply voltage

Nominal value:	24 VDC
Permissible ripples:	4,0 Vss within the permissible voltage range
Permissible voltage range:	19.5 ... 31 VDC, including ripples
Current consumption:	max. 0.8 A (depends on installed configuration)
Short-circuit current:	2.5 A (fuse)

EMC

Noise emission to EN 55022:	Class an industry environment)
Noise immunity to IEC 1000-4-2 (ESD):	Judgement criterion B
Noise immunity to IEC 1000-4-4 (Burst):	Judgement criterion B
Noise immunity to IEC 1000-5-5 (Surge):	Judgement criterion B

2.2 Addressing

General information about addressing

In order to be able to address the devices in the INTERBUS system directly, each device has an unambiguous address assigned. In addition, each INTERBUS module possesses an identification code (ID code) that shows the connected configuration unambiguously.

Module addressing of the INDRAMAT SPS

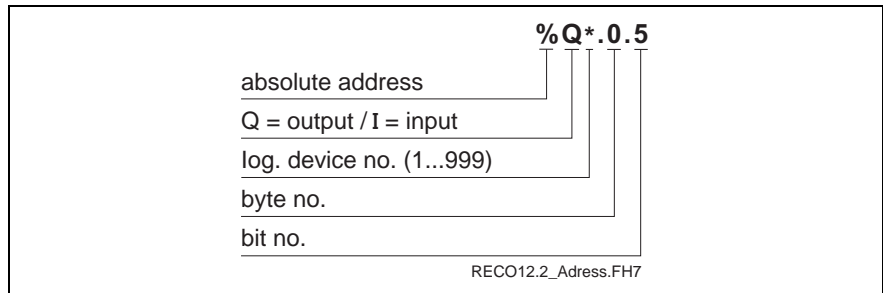

Figure 2-6: Typical address selection for an output module

Address selection for input modules

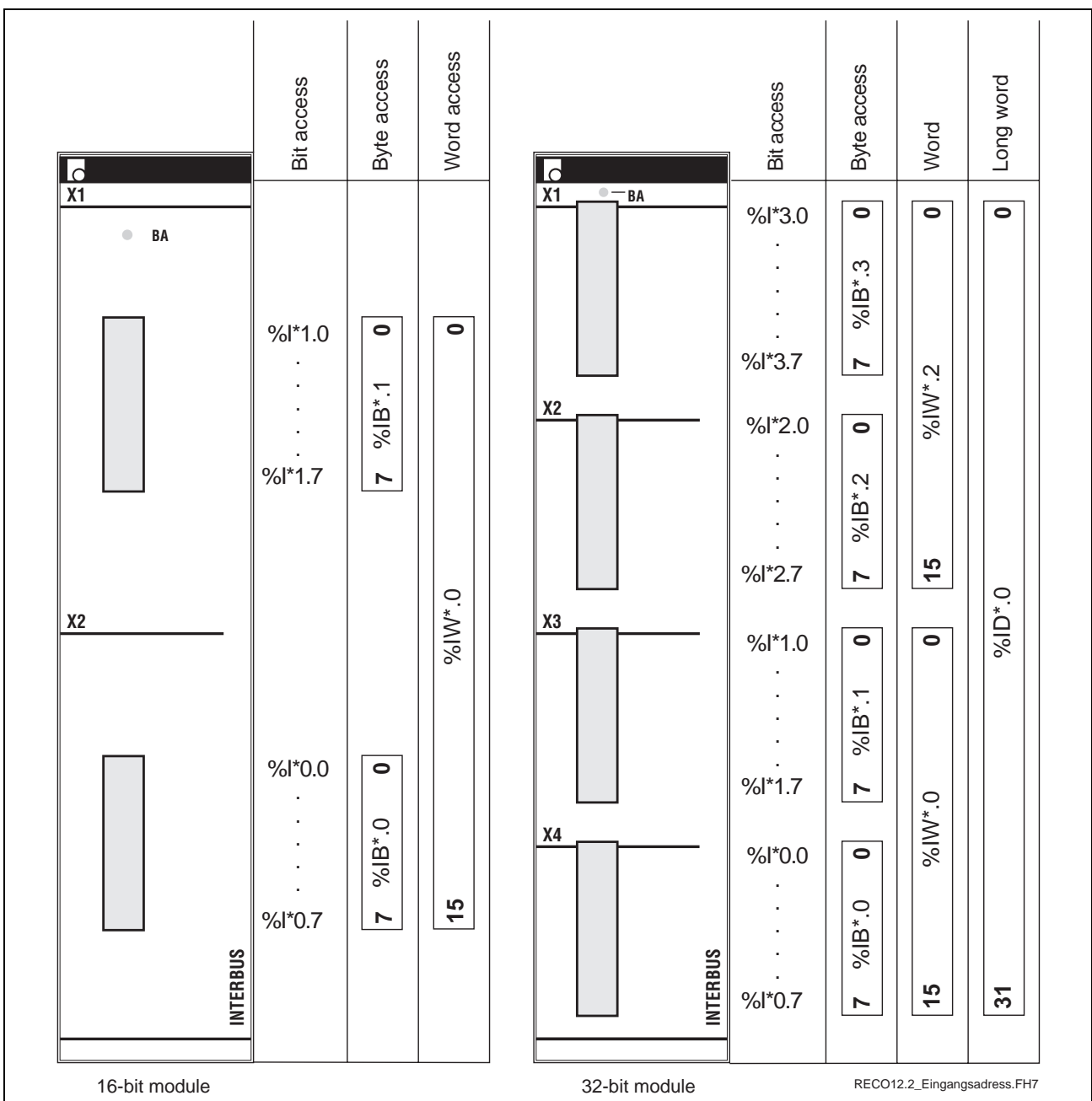

Figure 2-7: Bit, byte, word, and long word addresses for input modules

Address selection for output modules

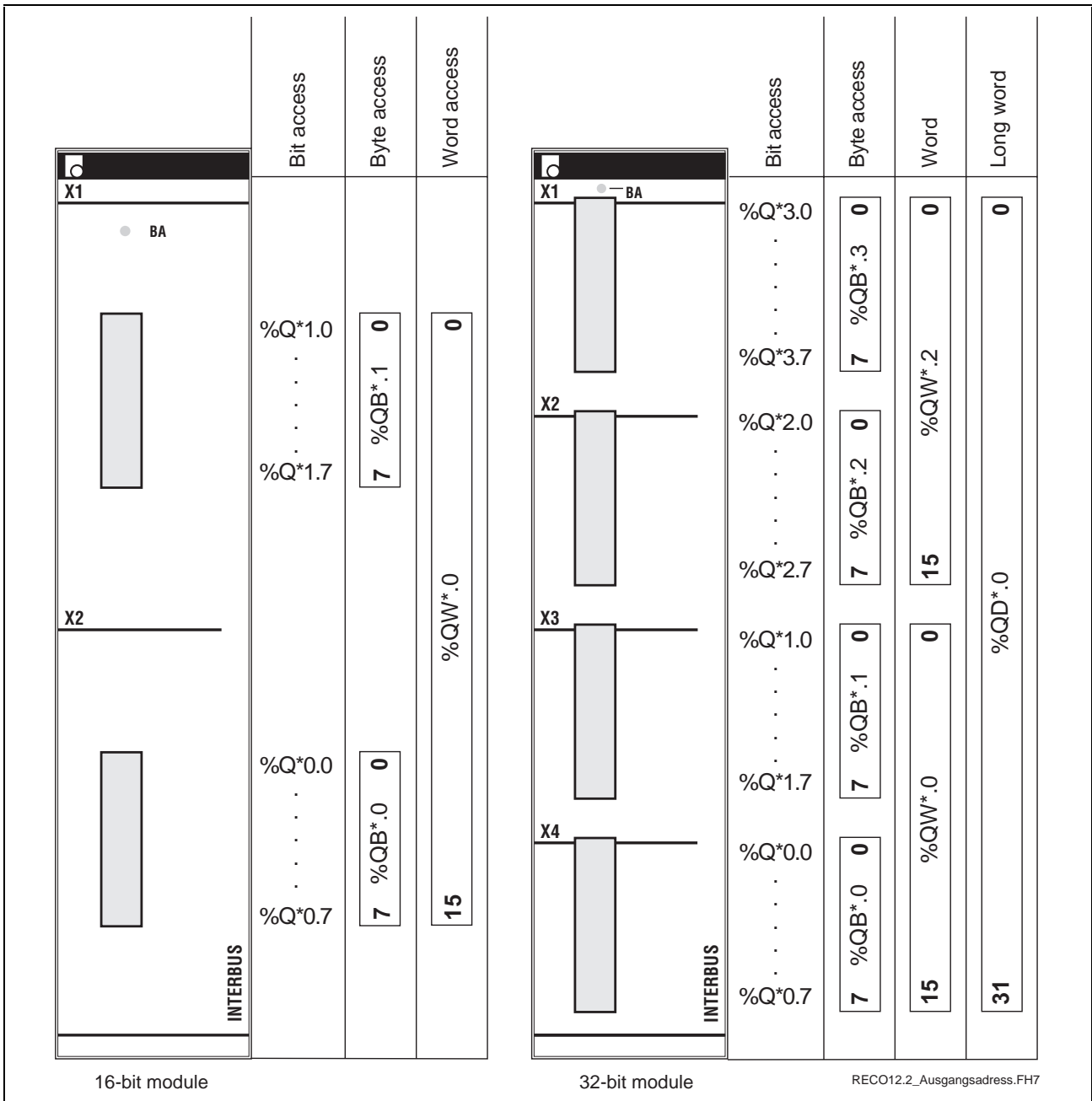

Figure 2-8: Bit, byte, word, and long word addresses for output modules

3 RMK12.2-IBS-BKL INTERBUS Bus Terminal

3.1 Brief Description

The INTERBUS bus terminal RMK12.2-IBS-BKL connects the I/O modules of a RECO station with the INTERBUS network. The interface is a slave according to the INTERBUS standard. The incoming and outgoing interface is available through 9-way male/female connectors. The RMK12.2-IBS-BKL bus terminal permits a maximum of 15 I/O modules to be used via the outgoing INTERBUS I/O bus. The actual number of modules mainly depends on the inbuilt power supply unit that provides for the isolated power supply of the connected I/O modules (see RECO12.2 Configuration Limits)

3.2 Dimensions

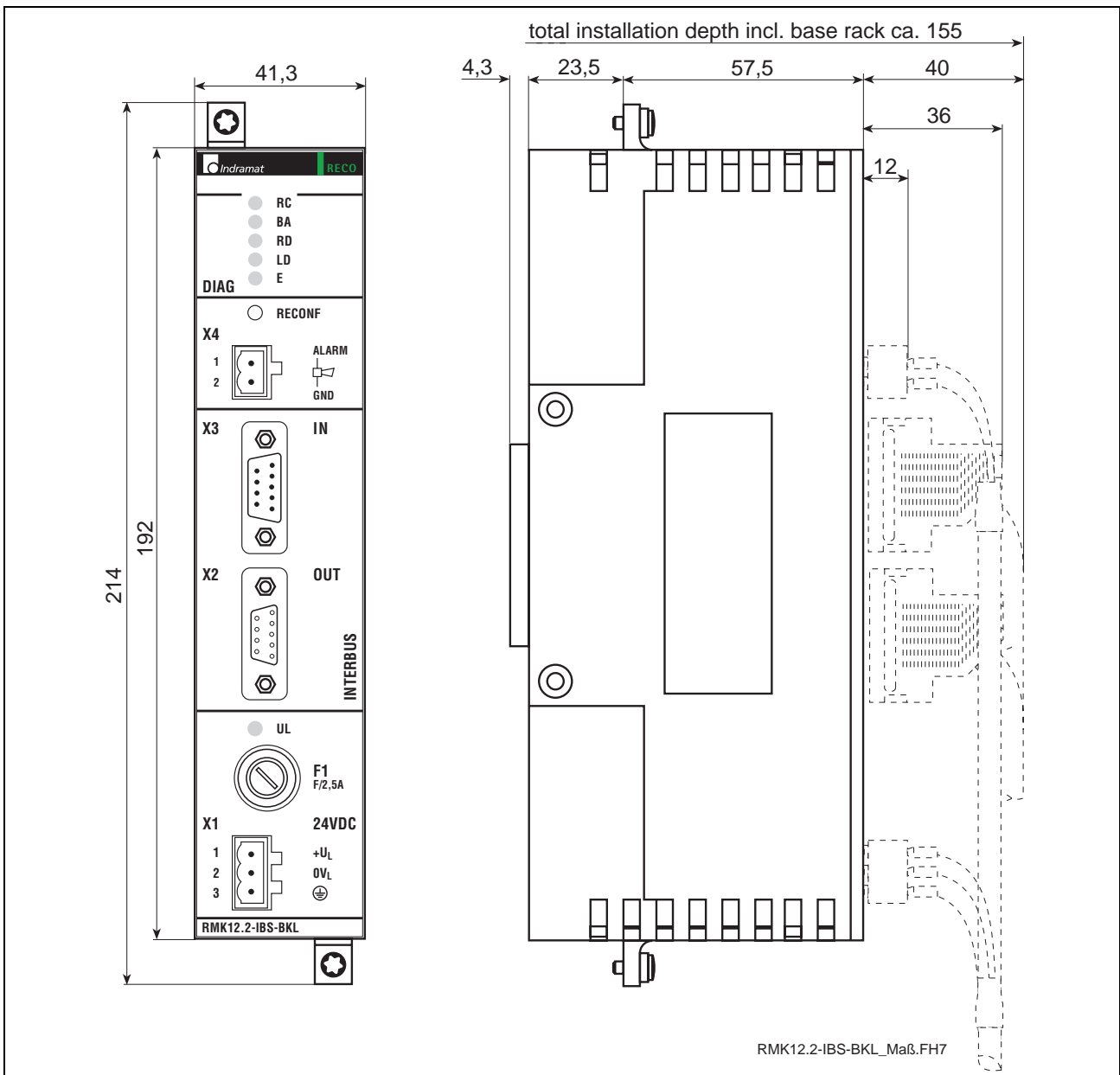

Figure 3-9: Mounting dimensions of RMK12.2-IBS-BKL

3.3 ID Code:

08_(HEX) = 8_(DEC)

3.4 Pin Assignments

Mains connection and alarm

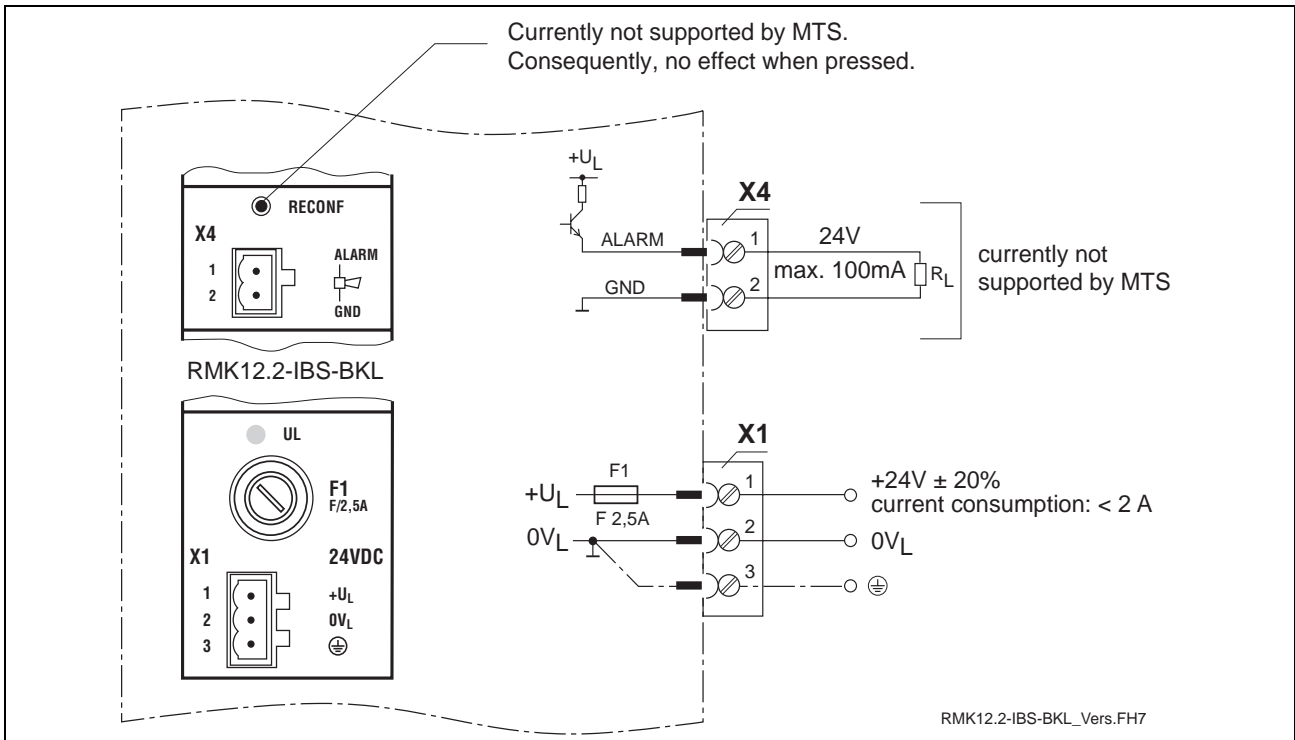

Figure 3-10: Pin assignments of mains connection and alarm

INTERBUS

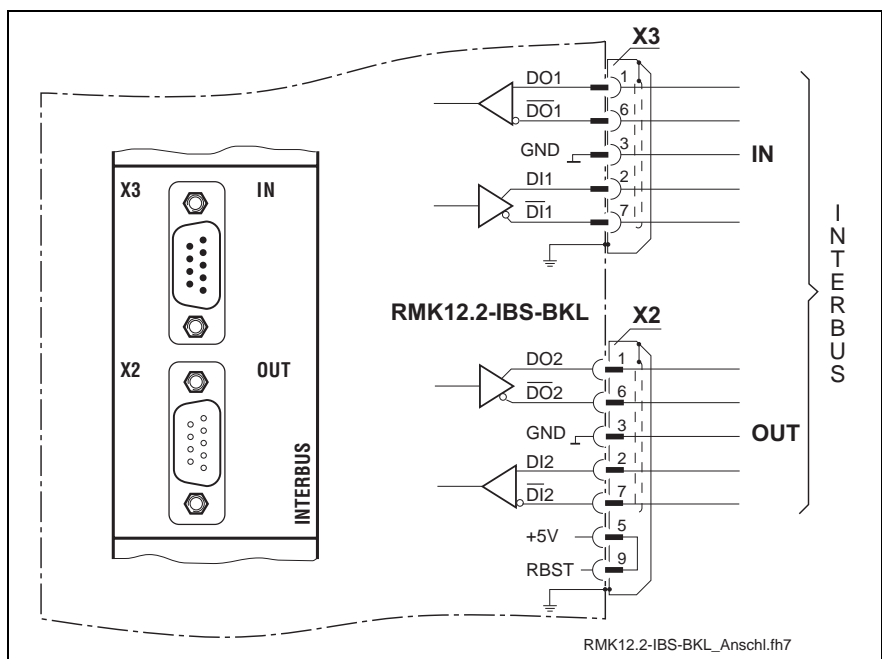

Figure 3-11: Pin assignments of the INTERBUS interface

Diagnoses

RC	LED green	Remote bus Check Monitoring the incoming remote bus (X3) ON: Incoming remote bus connection is established OFF: Incoming remote bus connection is disturbed
BA	LED green	Bus-Active ON: Data transfer on the INTERBUS is active OFF: No data transfer
RD	LED red	Remote bus Disable ON: The ongoing remote bus is switched off OFF: The ongoing remote bus is connected
LD	LED red	Local bus Disable ON: The ongoing local bus is switched off OFF: The ongoing local bus is connected

4 RME12.2-16-DC024 INTERBUS Input Module

4.1 Brief Description

The digital 24 VDC input modules are designed for connecting digital control signals that are produced by pushbuttons, limit switches or electronic proximity switches. The 16 inputs are arranged in 2 isolated potential groups.

4.2 Dimensions

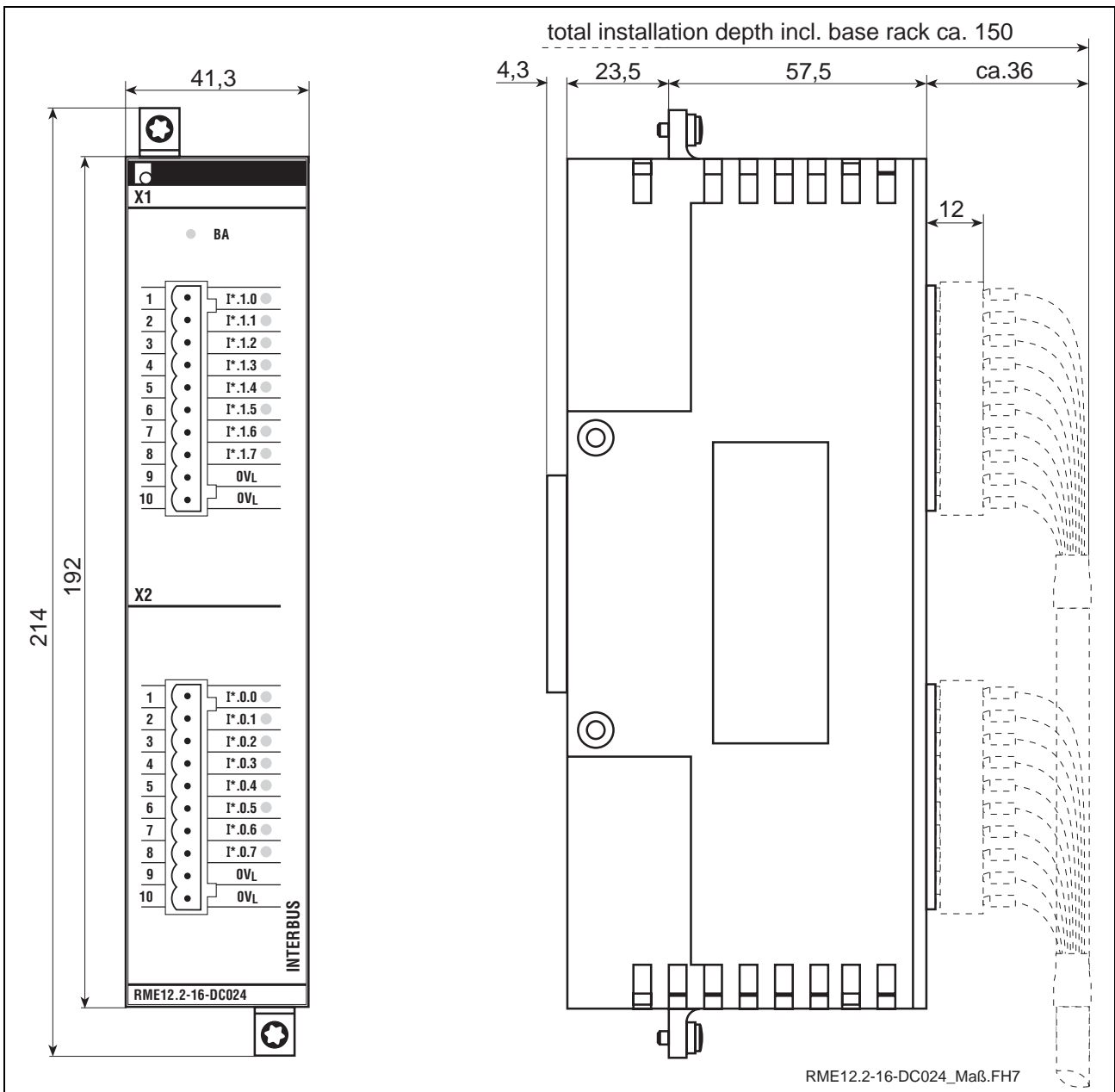

Figure 4-12: Mounting dimensions of RME12.2-16-DC024

4.3 Pin Assignments

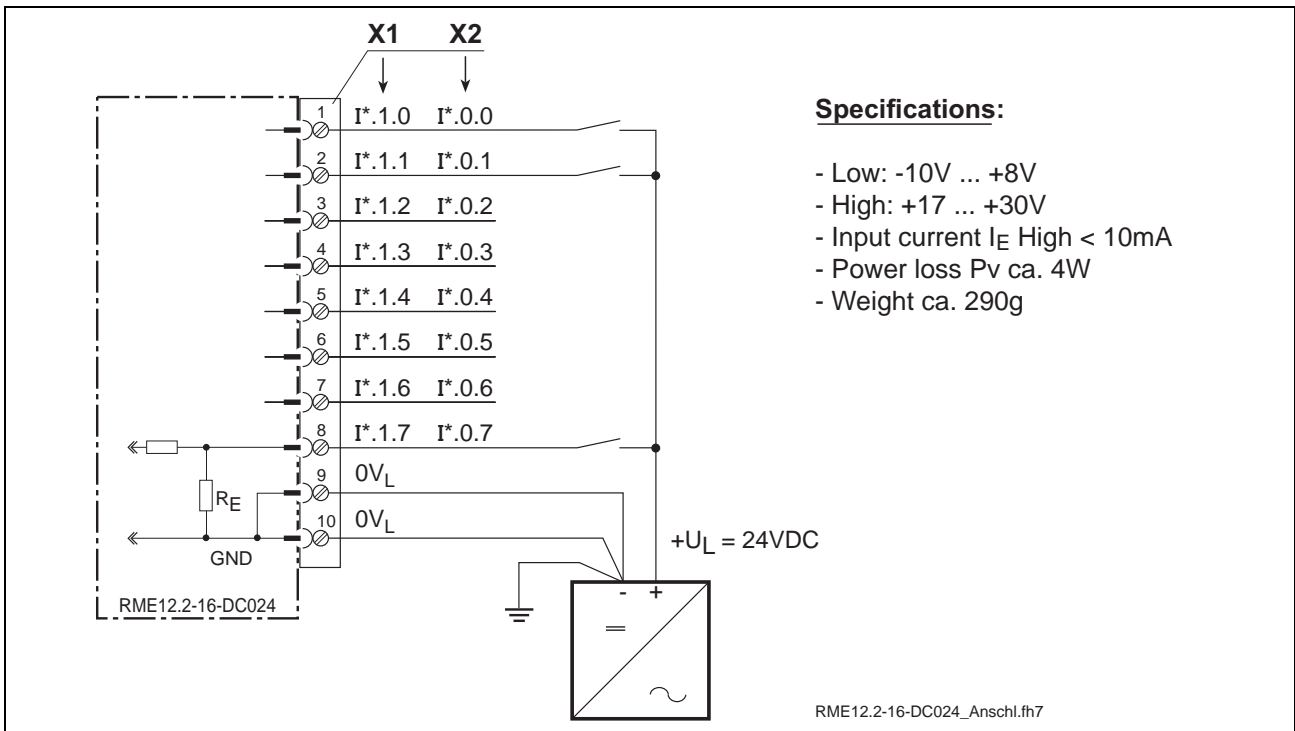

Figure 4-13: Wiring diagram of RME12.2-16-DC024

4.4 Addressing

Local bus device:	DI		
ID code:	BE _(HEX)	=	190 _(DEC)
Data width:	1 word	=	16 bits

5 RME12.2-32-DC024 INTERBUS Input Module

5.1 Brief Description

The digital 24 VDC input modules are designed for connecting digital control signals that are produced by pushbuttons, limit switches or electronic proximity switches. The 32 inputs are arranged in 4 isolated potential groups.

5.2 Dimensions

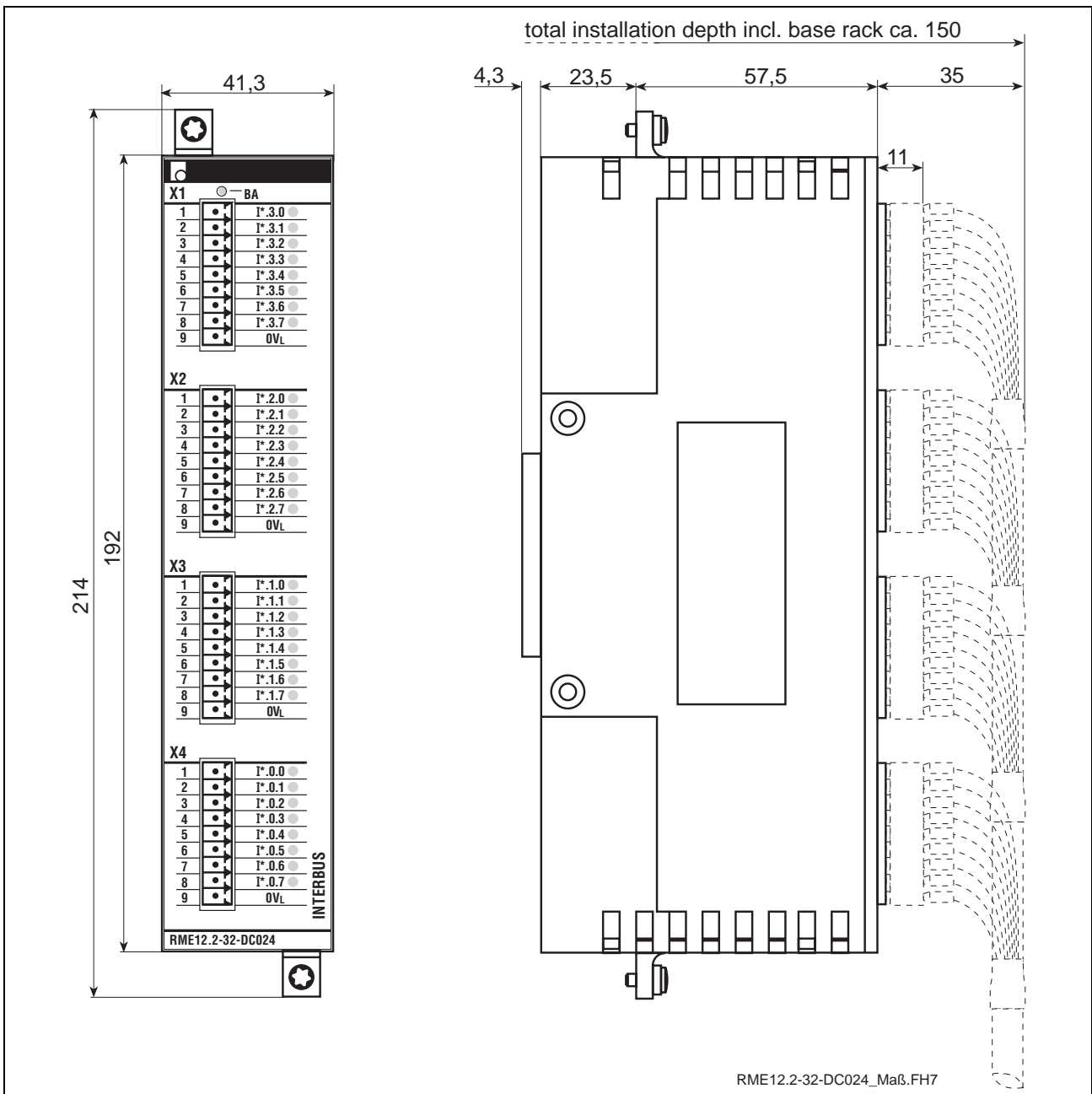

5.3 Pin Assignments

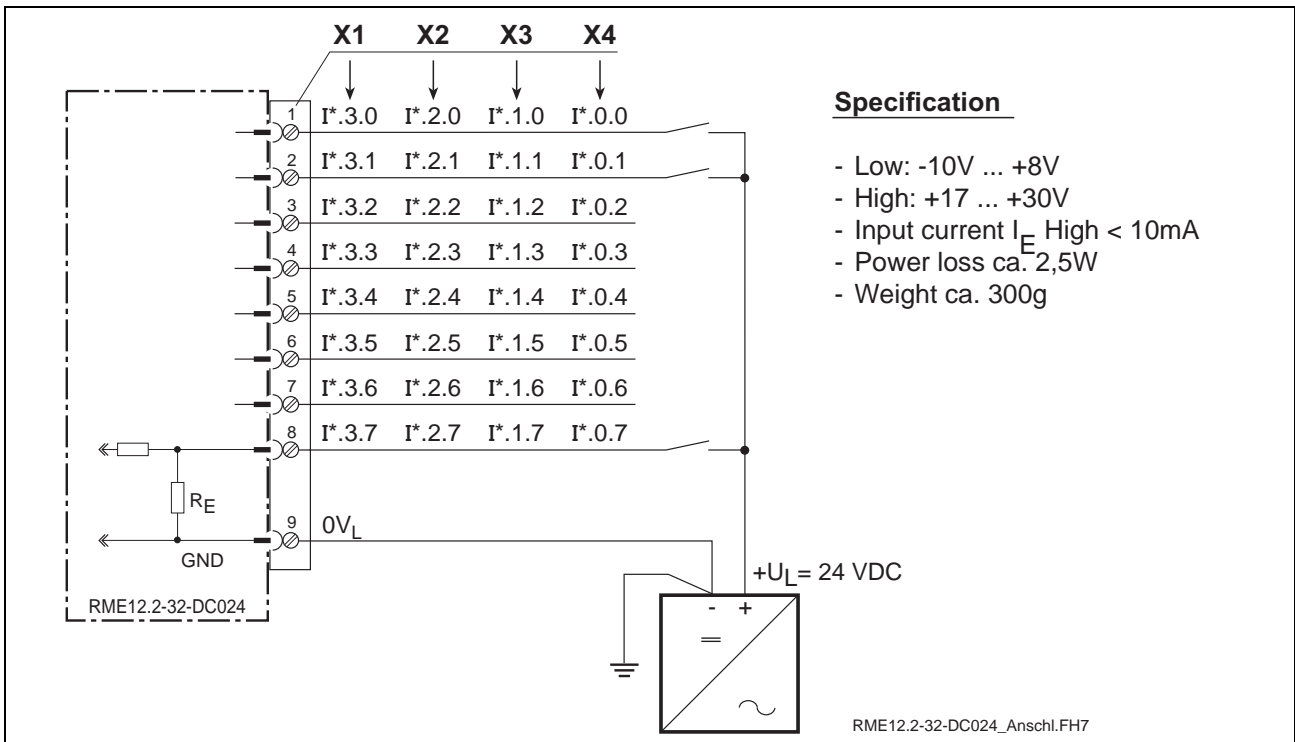

Figure 5-15: Wiring diagram of RME12.2-32-DC024

5.4 Addressing

Local bus device:	DI		
ID code:	BE _(HEX)	=	190 _(DEC)
Data width:	2 words	=	32 bits

6 RME12.2-16-AC115 INTERBUS Input Module

6.1 Brief Description

AC sources of a maximum rating of 120VAC / 60Hz can directly be connected to the digital 115VAC input modules. The 16 AC inputs are arranged in 2 isolated potential groups.

6.2 Dimensions

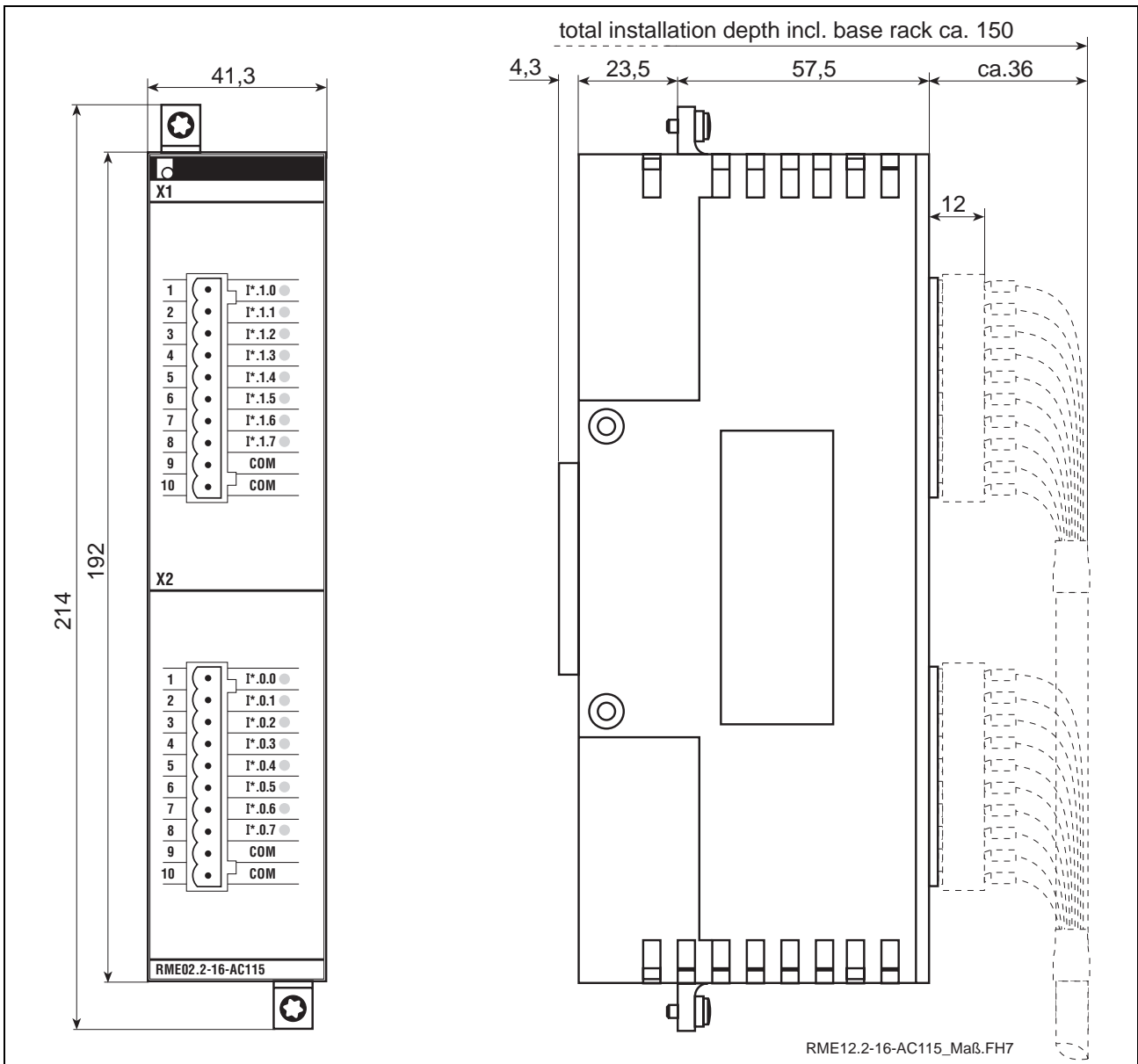

Figure 6-16: Mounting dimensions of RME12.2-16-AC115

6.3 Pin Assignments

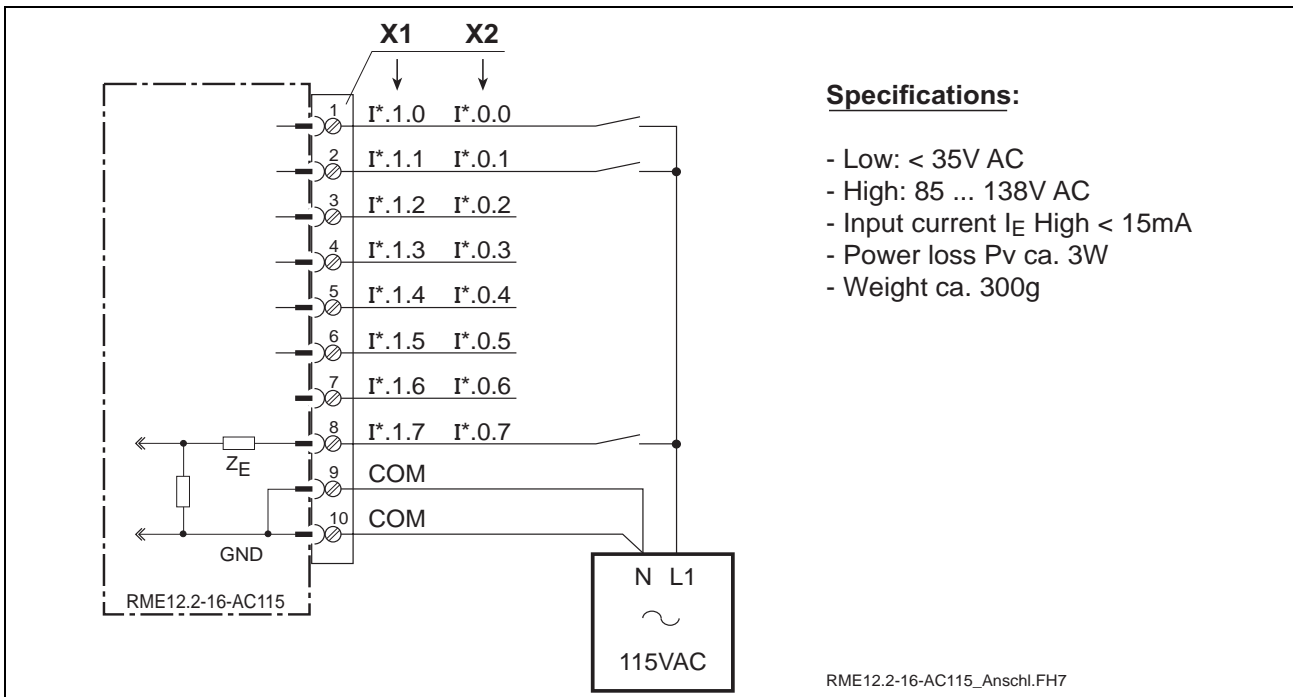

Figure 6-17: Wiring diagram of RME12.2-16-AC115

6.4 Addressing

Local bus device:	DI		
ID code:	BE _(HEX)	=	190 _(DEC)
Data width:	1 word	=	16 bits

7 RMA12.2-16-DC024-200 INTERBUS Output Module

7.1 Brief Description

The digital 24VDC output modules are designed for the connection of digital actuators, such as solenoid valves, contactors, or indicator lights. The 16 outputs are FET transistor switches (active 1 switching) that are arranged in 2 isolated groups of 8 outputs each. Each 24V output can source loads up to 2 A.

7.2 Dimensions

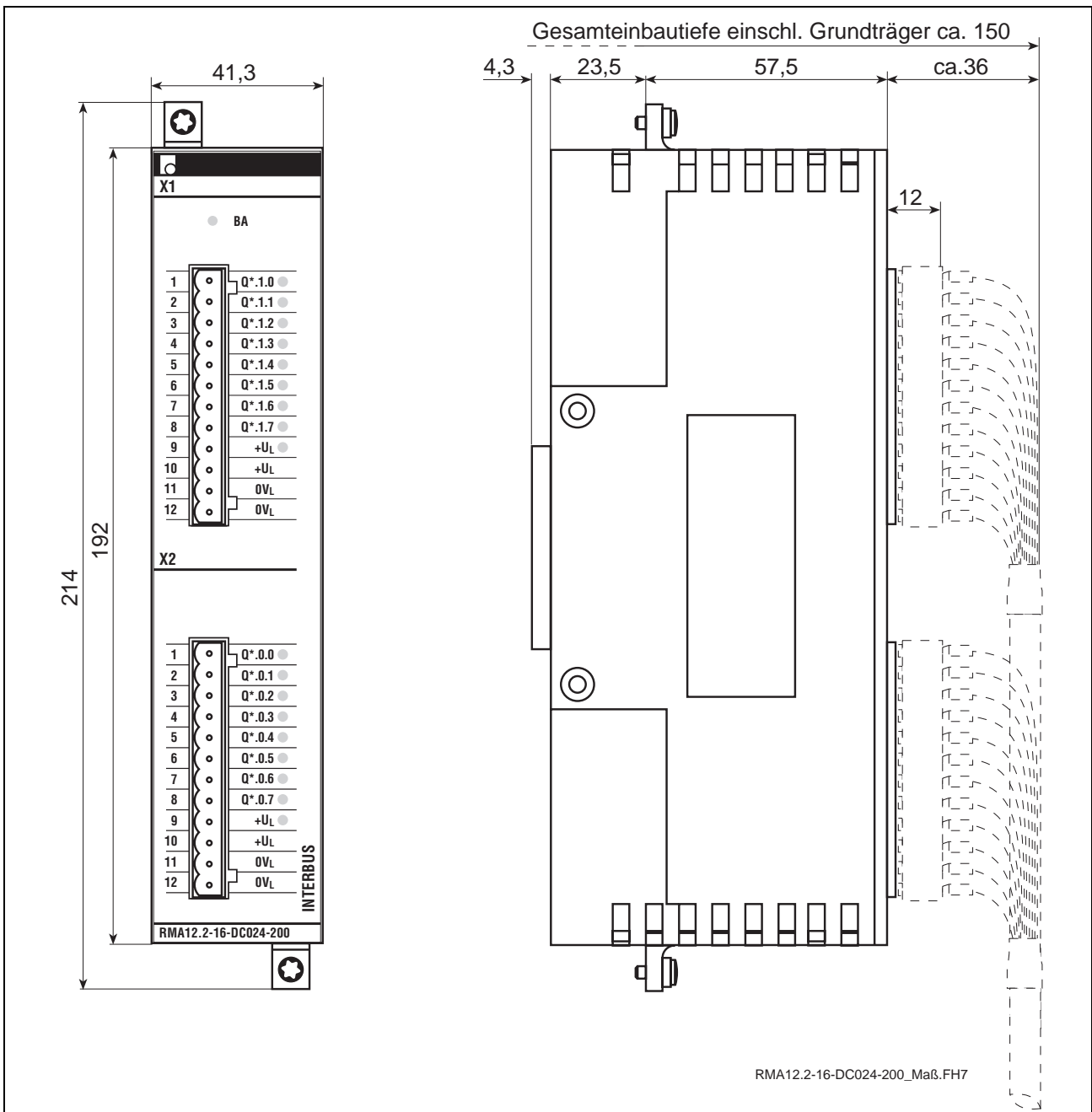

Figure 7-18: Mounting dimensions of RMA12.2-16-DC024-200

7.3 Pin Assignments

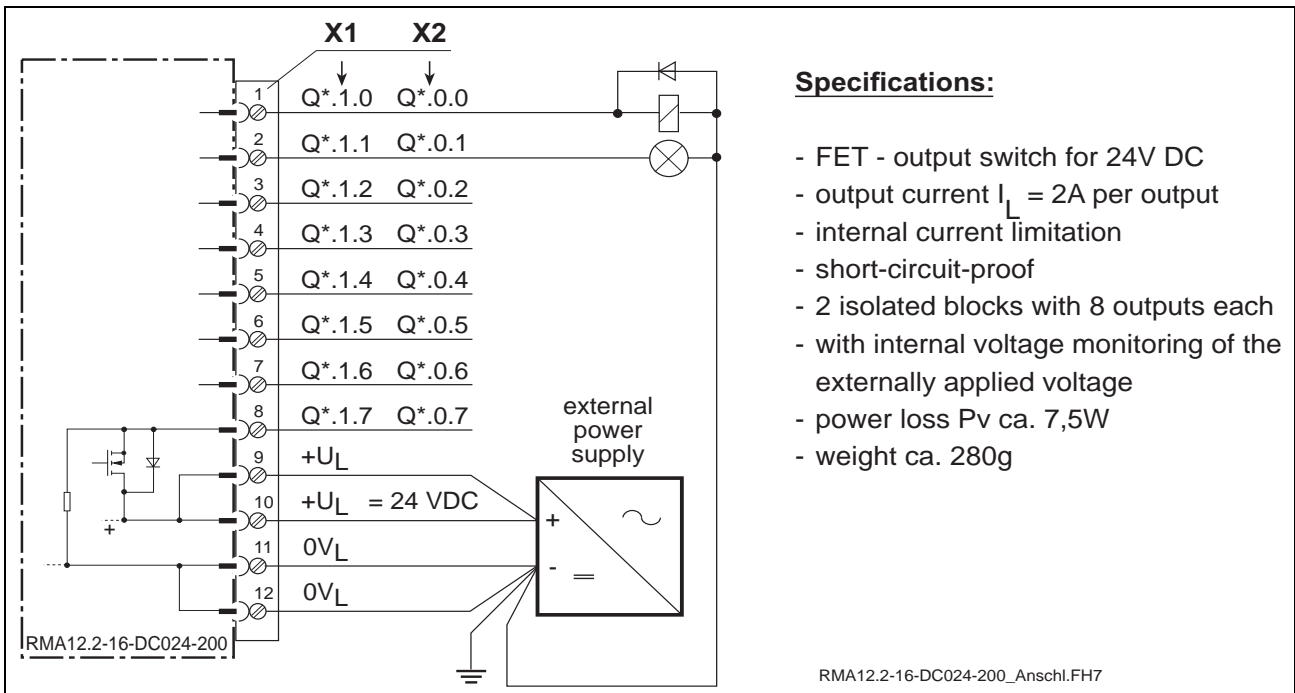

Figure 7-19: Wiring diagram of RMA12.2-16-DC024-200

7.4 Addressing

Local bus device:	DO		
ID code:	BD _(HEX)	=	189 _(DEC)
Data width:	1 word	=	16 bits

8 RMA12.2-32-DC024-050 INTERBUS Output Module

8.1 Brief Description

The digital 24VDC output modules are designed for the connection of digital actuators, such as solenoid valves, contactors, or indicator lights. The 32 outputs are FET transistor switches (active 1 switching) that are arranged in 4 isolated groups of 8 outputs each. Each 24V output can source loads up to 500 mA.

8.2 Dimensions

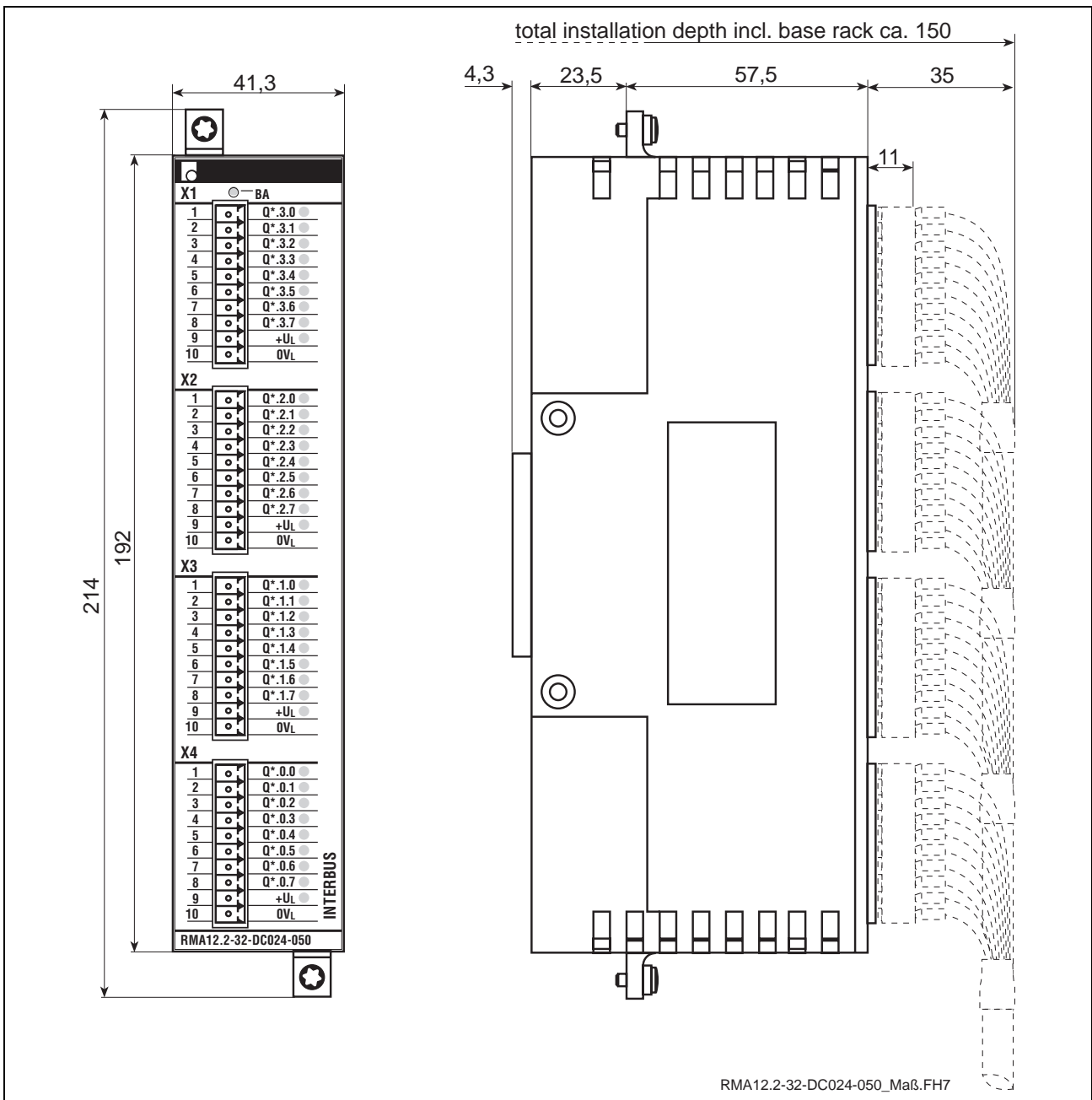

Figure 8-20: Mounting dimensions of RMA12.2-32-DC024-050

8.3 Pin Assignments

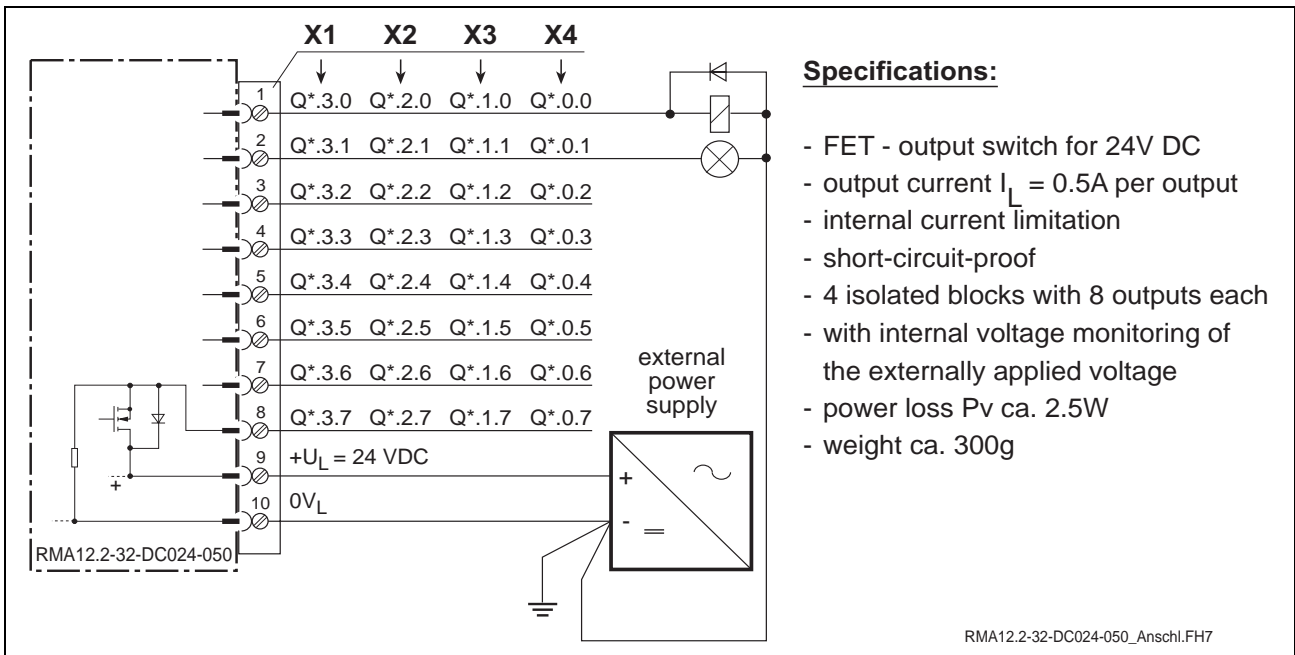

Figure 8-21: Wiring diagram of RMA12.2-32-DC024-050

8.4 Addressing

Local bus device:	DO		
ID code:	BD _(HEX)	=	189 _(DEC)
Data width:	2 words	=	32 bits

9 RMA12.2-16-AC230-200 INTERBUS Output Module

9.1 Brief Description

The digital AC output modules are designed for the connection of digital actuators that operate on the mains voltage. The 16 active 1 switching outputs are arranged in 2 isolated groups of 8 outputs each. Each 230V AC output is able to source up to 2A.

9.2 Dimensions

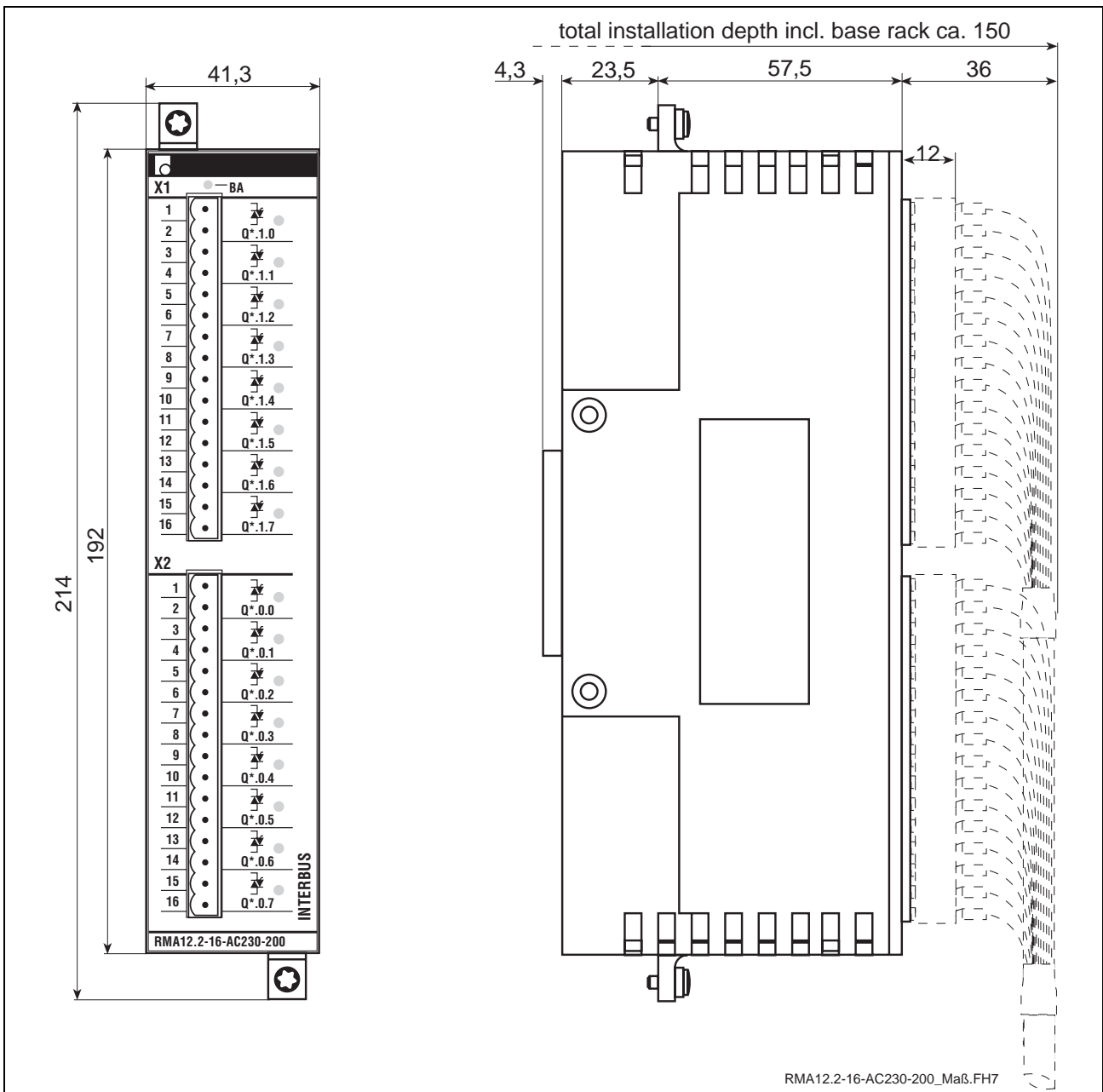

Figure 9-22: Mounting dimensions of RMA12.2-16-AC230-200

9.3 Pin Assignments

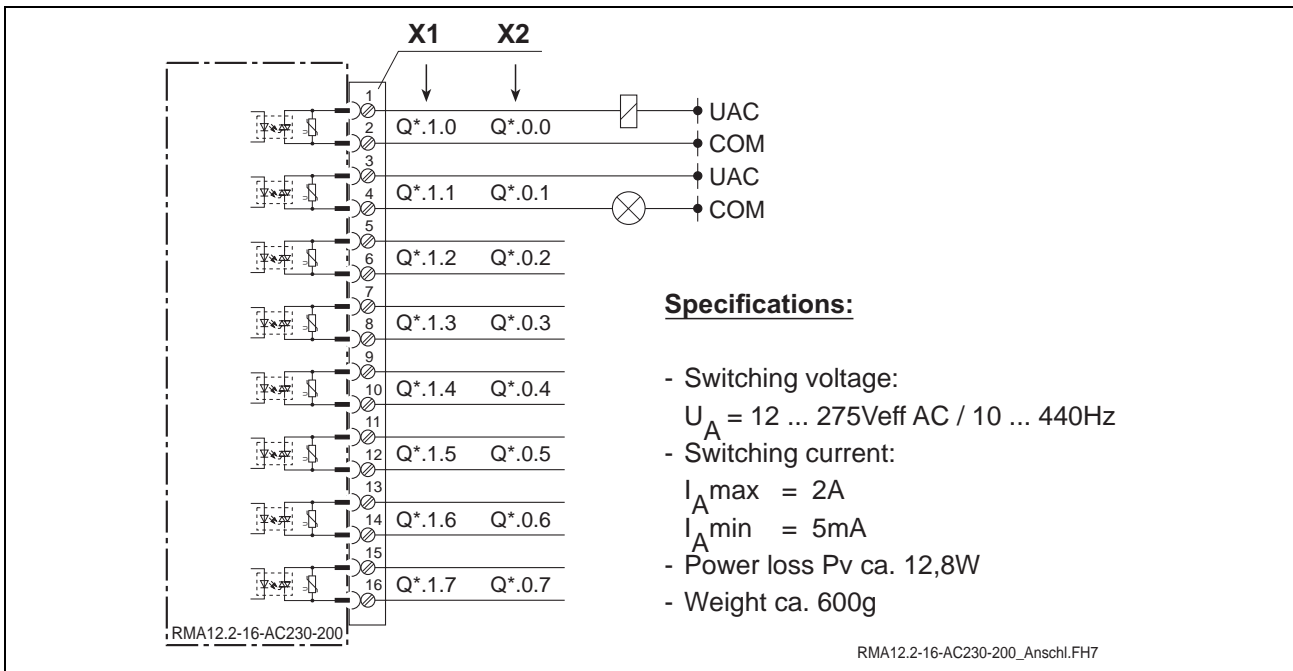

Figure 9-23: Wiring diagram of RMA12.2-16-AC230-200

9.4 Addressing

Local bus device:	DO		
ID code:	BD _(HEX)	=	189 _(DEC)
Data width:	1 word	=	16 bits

10 RMA12.2-16-RE230-200 INTERBUS Output Module

10.1 Brief Description

The digital relay output modules are designed as floating switching contacts for AC and DC. The 16 active 1 switching outputs are arranged in 2 isolated groups of 8 outputs each. Depending on the load, the maximum switching capacity of each output is between 50W and 200W (Figure 10-25: Load-related output rating).

10.2 Dimensions

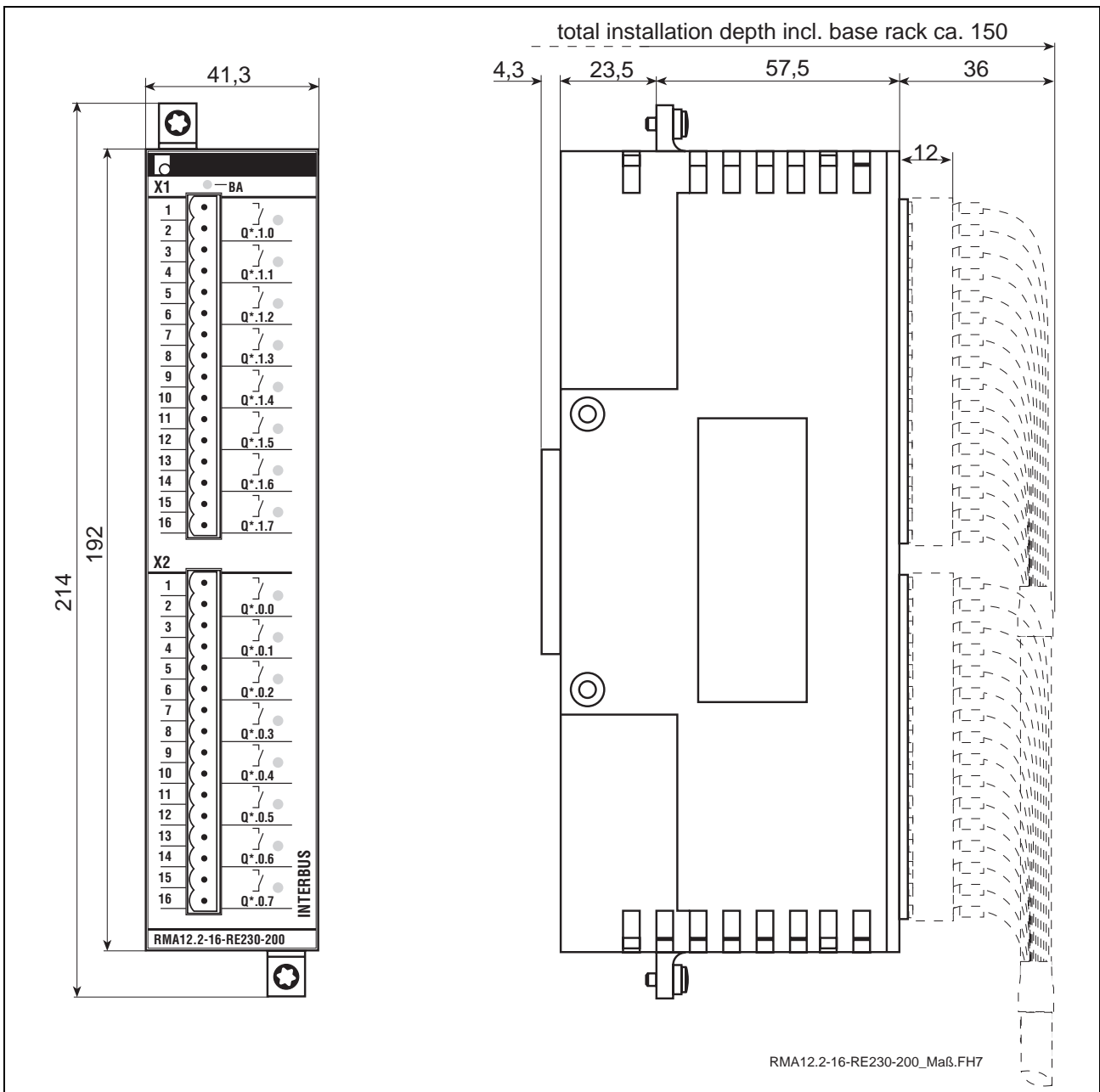

Figure 10-24: Mounting dimensions of RMA12.2-16-RE230-200

10.3 Load Rating Curve of the Outputs

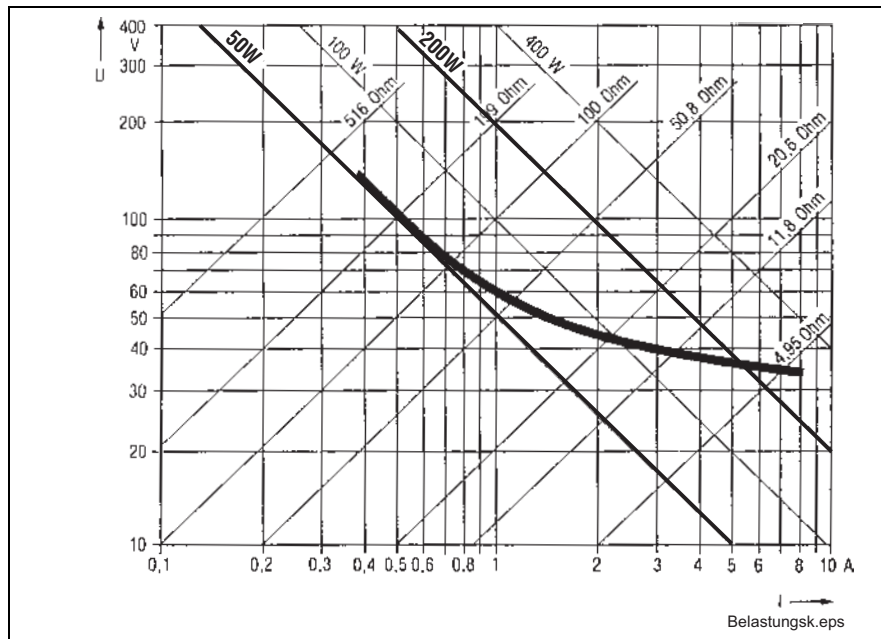

Figure 10-25: Load-related output rating

10.4 Pin Assignments

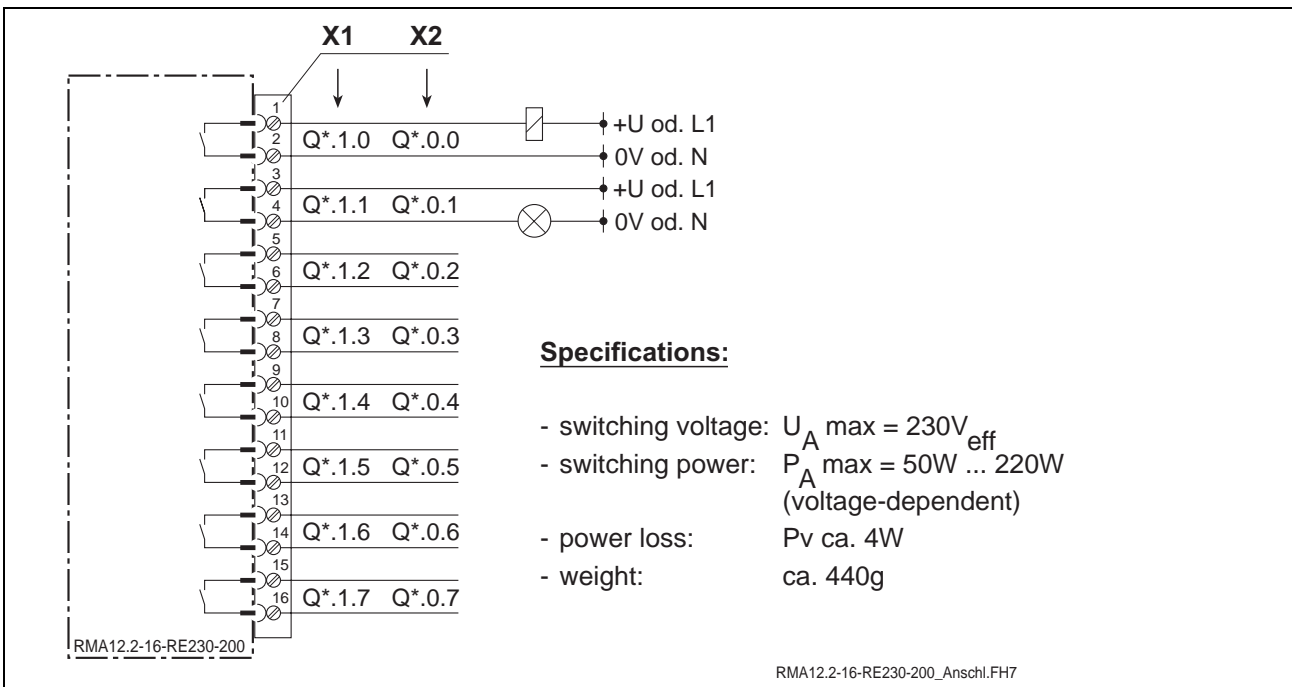

Figure 10-26: Wiring diagram of RMA12.2-16-RE230-200

10.5 Addressing

Local bus device:	DO		
ID code:	BD _(HEX)	=	189 _(DEC)
Data width:	1 word	=	16 bits

11 RMC12.2-2E-1A INTERBUS Analog Module

11.1 General

The RECO module RMC12.2-2E-1A is an analog I/O module for the INTERBUS RECO system. The module is used as a local bus device in a RMB12.2-02 or RMB12.2-04 base rack in conjunction with the RMK12.2-IBS-BKL INTERBUS bus terminal.

The module possesses 2 isolated input channels and one isolated output channel. 2- and 3-wire actuators and/or 2-/3- and 4-wire sensors can be connected to these outputs. Each input connector has its own constant current source (2.5 mA) that eliminates the need for an external power supply for most sensors.

The analog output provides in parallel +/- 10V voltage and 0 - 20 mA current. Each input and output has its own connector. The module's power supply is provided via the local bus. Voltage conditioning, voltage monitoring and reset detection are performed on the RMK12.2-IBS-BKL bus terminal.

Analog section and INTERBUS section are isolated via optocouplers.

DA and AD conversions are always synchronous with the INTERBUS cycle so that time overlapping is not possible and the converted values are always valid.

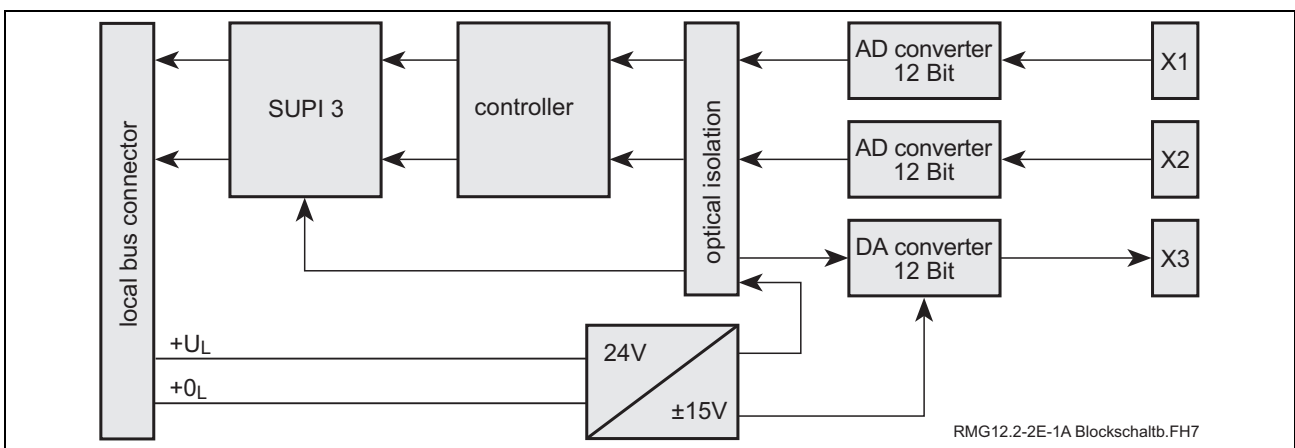

Figure 11-27: Block diagram

11.2 Dimensions

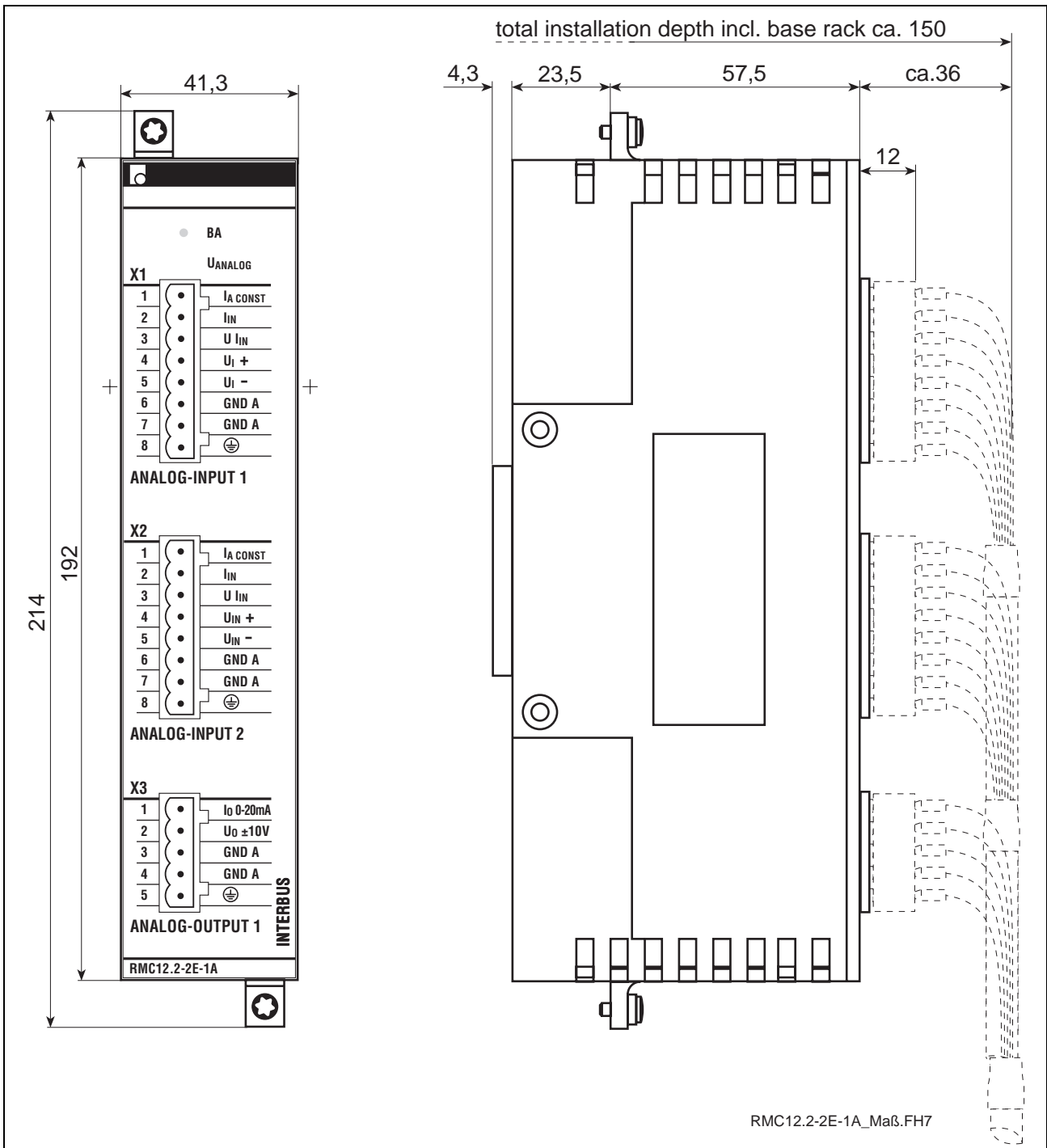

Figure 11-28: Dimensions of RMC12.2-2E-1A

11.3 Analog Value Inputs X1 and X2

To suppress the influence of long lines, the X1 and X2 analog inputs are set up as differential inputs with a high common-mode rejection value. Thus, the influence of the line length can be neglected.

The measuring range of the inputs can be programmed through parameters.

Input ranges	
Bipolar input voltage range:	$\pm 0,5V$; $\pm 1V$; $\pm 5V$; $\pm 10V$
Bipolar input current range:	$\pm 20mA$
Resistance measurement:	0 - 2000 Ω (internal current source) 0 < 20K Ω (external voltage source)
Temperature measurement:	Pt 100: -100°C....+850°C
Output ranges	
Bipolar output voltage range:	$\pm 10V$
Unipolar output current ranges:	0 - 20mA

11.4 Entering the Analog Values

The analog value conversion is performed by an AD converter with a resolution of 16 bits that employs the successive approximation method. The conversion time is approximately 35 μs .

The following measuring inaccuracies occur inside the ambient temperature range 0...50°C:

- Voltage:

Measuring range 0.5V:	0.4% MEW (upper range limit)
Measuring range 1V:	0.4% MEW
Measuring range 5V:	0.2% MEW
Measuring range 10V:	0.2% MEW
- Current:

Measuring range 20mA:	0.3% MEW
-----------------------	----------
- Resistance:

Measuring range 200 Ω :	0.6% MEW
Measuring range 400 Ω :	0.6% MEW
Measuring range 2000 Ω :	0.4% MEW
- Temperature (Pt100):

Measuring range -100...266°C:	1.3% MEW
Measuring range -100...850°C:	1.0% MEW

The digital value is provided as a 16-bit word in 2's complement representation via the INTERBUS.

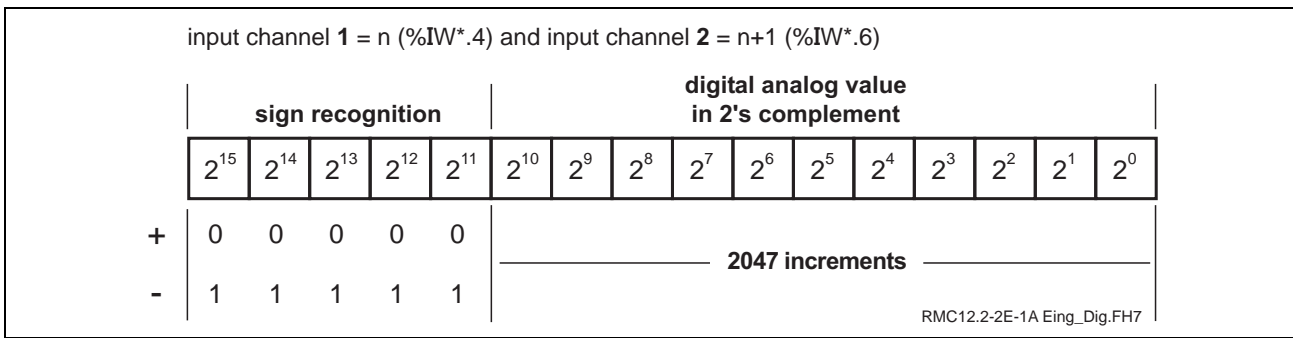

Figure 11-29: Representation of the input channels 1 and 2

11.5 Current Measurement

In current measurement, the current that is to be measured is conducted via an inbuilt 250Ω precision resistor, and the voltage drop across this resistor is measured.

The measuring error is 0.3% of the upper range limit.

11.6 Analog Value Output X3

The D/A converter for analog value output has a resolution of 12 bits and a conversion time of < 5μs. This means that the analog value is available 5μs after the INTERBUS cycle has been completed.

Current output runs in parallel to the voltage output (0V....10V) at a resolution of 2047 steps.

- +10V = 20mA provides a resolution of 9.77μA/increment
- 0V = 0mA
- -10V = 0mA

Note: The current resolution error in the temperature range 0...50°C is 0.2% of the limit value; the voltage resolution error is 1% of the output value.

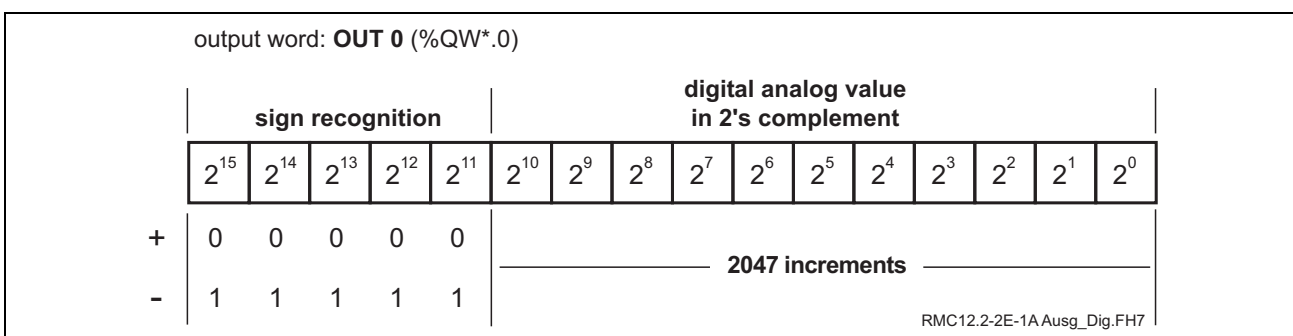

Figure 11-30: Representation of the OUT 0 output word

11.7 Programming the Input Measuring Ranges

The parameters for the input measuring ranges are transferred in the 2nd output word of the INTERBUS transmission. It must be ensured that the parameters have been set accordingly before input measurement is started.

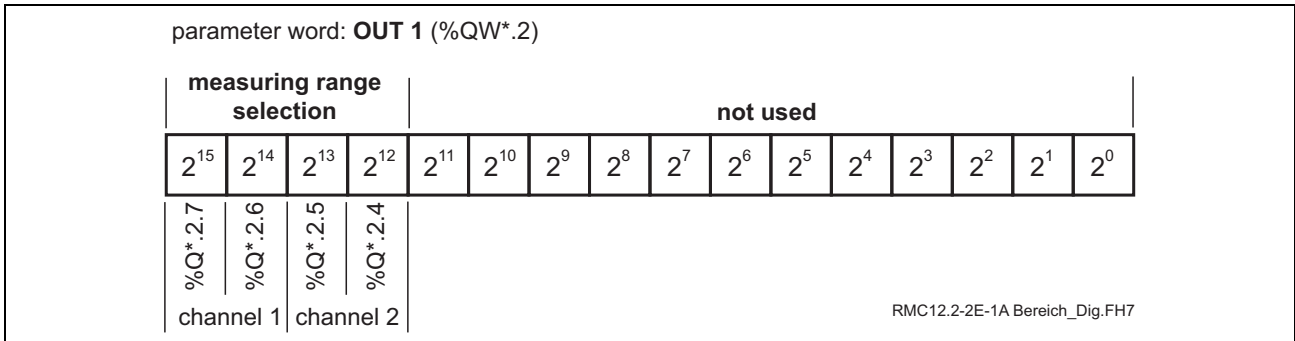

Figure 11-31: Representation of the OUT 1 parameter word

Channel 1		Channel 2		Voltage:	Current	Resistance	Temperature
0	0	0	0	±0.5V	----	200Ω	-100°C ... +266°C
0	1	0	1	±1.0V	----	400Ω	-100°C ... +850°C
1	0	1	0	±5.0V	0 - 20mA	2000Ω	----
1	1	1	1	±10.0V	----	----	----

Figure 11-32: Overview of the selectable measuring ranges

11.8 Structure of the IN/OUT Registers in the INTERBUS

Word M	Word M + 1	IBS word
Analog value channel 1 (%IW*.4)	Analog value channel 2 (%IW*.6)	IN register
Output word OUT 0 (%QW*.0)	Parameter word OUT 1 (%QW*.2)	OUT register

Figure 11-33: Register structure

11.9 Addressing

ID code: BF_{HEX} = 191_{DEC}
 Data width: 2 words = 32 bits

11.10 Diagnosis Indicators

BA	LED green	Bus Active
	ON:	Data transfer is active
	OFF:	Data frames are not transferred
U_{Analog}	LED green	±15V indicator
	ON:	±15V present
	OFF:	±15V supply out of tolerance

11.11 Connector Pin Assignments

1	I_A CONST	2.5 mA constant current source for sensor power supply
2	I_{IN}	Current measuring input
3	U I_{IN}	Voltage measurement at I_A CONST
4	U_I +	Non-inverting voltage input
5	U_I -	Inverting voltage input
6	GND A	Analog ground
7	GND A	Analog ground
8	Screen	Pin for additional screening

Figure 11-34: Analog input connectors X1, X2

1	I_A 0 - 20 mA	Adjustable current output
2	U_A ±10V	Adjustable voltage output
3	GND A	Analog ground
4	GND A	Analog ground
5	Screen	Pin for additional screening

Figure 11-35: Analog output connector X3

11.12 Typical Applications

±10V voltage output

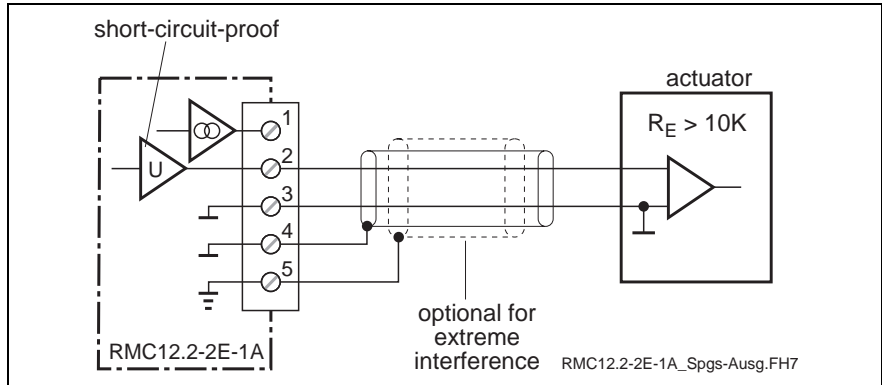

Figure 11-36: Typical wiring of voltage output

±10V voltage measurement ($R_{in} > 1M\Omega$)

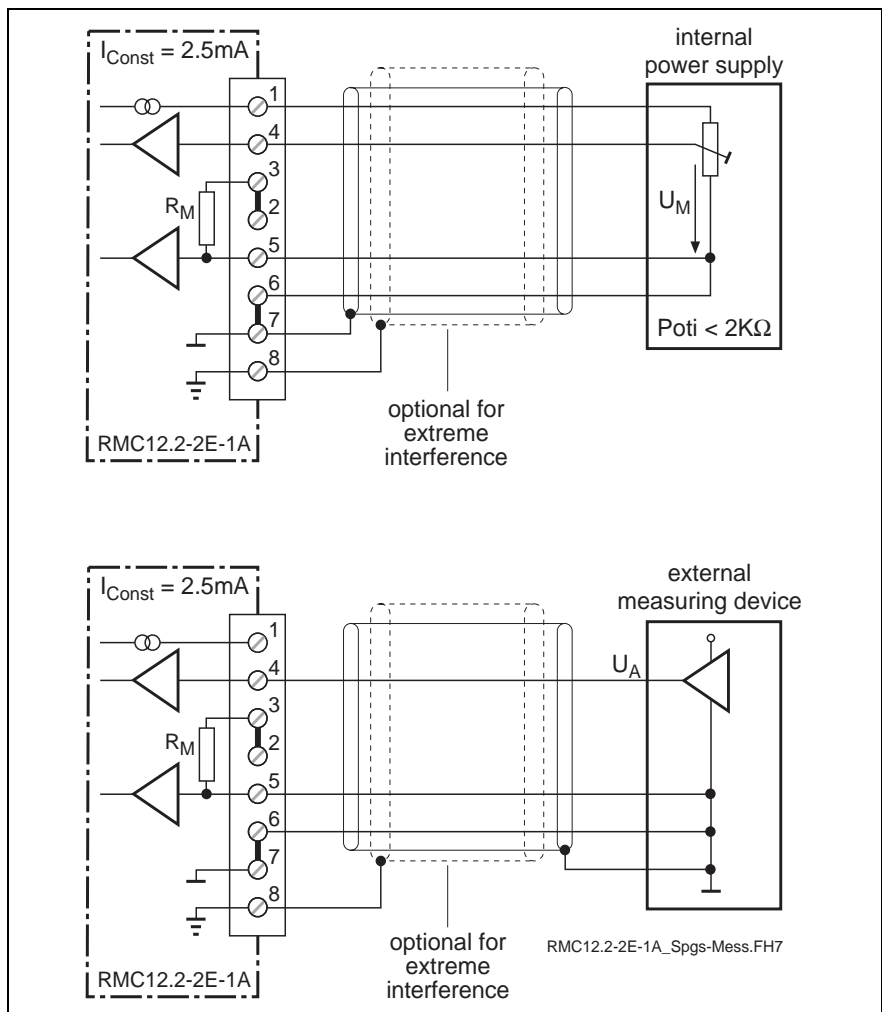

Figure 11-37: Typical wiring of voltage measurement

0 - 20mA current output

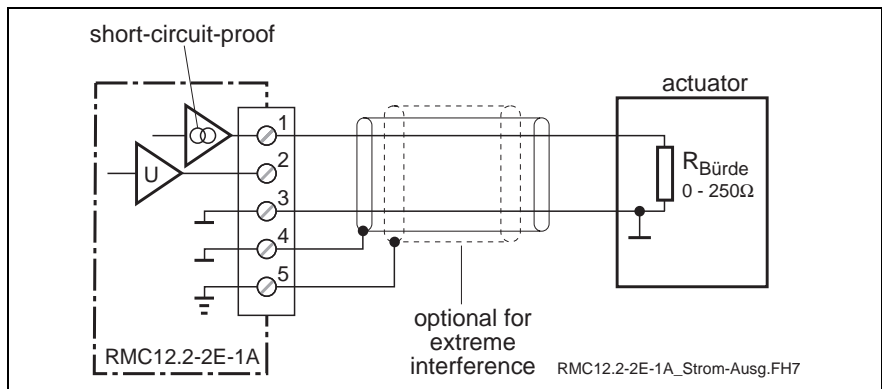

Figure 11-38: Typical wiring of current output

0 - 20mA current measurement

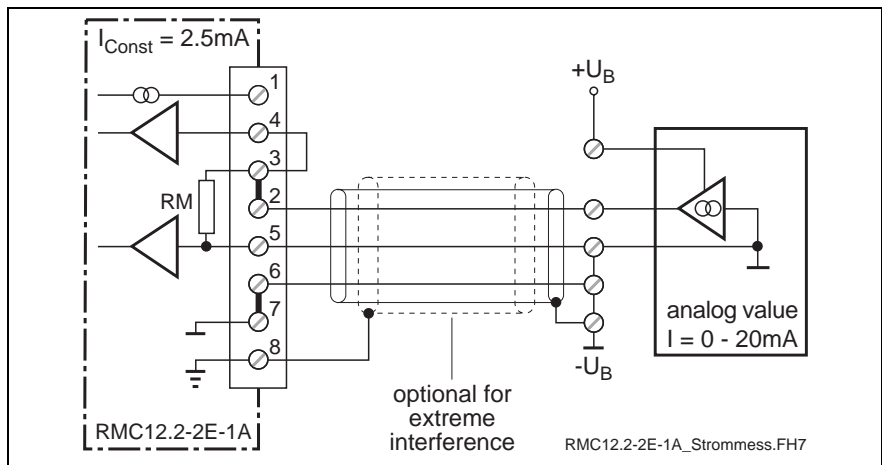

Figure 11-39: Typical wiring of current measurement

Temperature measurement using Pt100 element

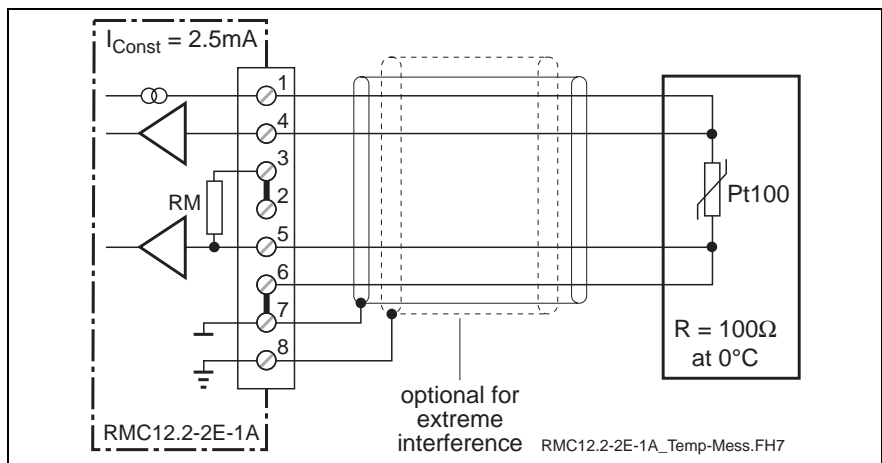

Figure 11-40: Typical connections for temperature measurement using Pt100 element

12 RECO12.2 Configuration Limits

12.1 General

The maximum number of modules is limited to one RMK12.12.2-IBS-BKL module and 15 I/O modules. With some modules, however, the maximum number of a specific module type must be taken into account.

The following modules can only be used in a limited number when all outputs are triggered at the same time:

RMA12.2-16-RE230-200 max. 8 modules

RMA12.2-32-DC024-050 max. 8 modules

RMA12.2-16-AC230-200 max. 8 modules

If the given limits must be exceeded, the number of outputs that can be switched simultaneously is reduced accordingly.

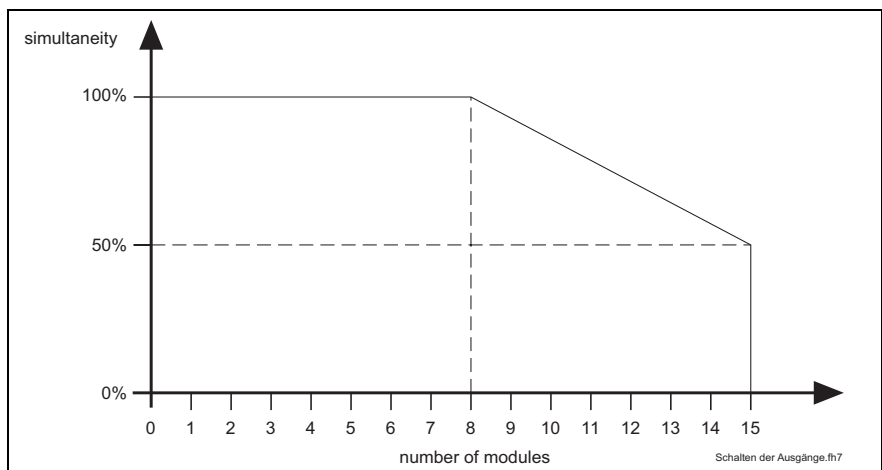

Figure 12-41: Maximum number of outputs that can be switched simultaneously.

12.2 Configuration-Related Current Consumption of the Bus Coupler Unit

The maximum current consumption of the entire RECO12.2 unit depends on the employed modules. The total current requirement of a configuration can easily be determined using the following table:

The power supply unit of the bus coupler module can provide a maximum of 2.5 A for the electronics of the modules. The power supply to the modules is not taken into account here; the corresponding modules must be fed separately.

Module type	Current consumption	Quantity	Total (mA)
RMK12.2-IBS-BKL (base consumption)	approximately 100mA	1	100
RME12.2-16-DC024	approximately 5 mA		
RME12.2-32-DC024	approximately 10 mA		
RME12.2-16-AC115	approximately 5 mA		
RMA12.2-16-DC024-200	approximately 30 mA		
RMA12.2-32-DC024-050 (max. 8 units)	approximately 60 mA		
RMA12.2-16-AC230-200 (max. 8 units)	approximately 60 mA		
RMA12.2-16-RE230-200 (max. 8 units)	approximately 160 mA		
Total current consumption:			

Figure 12-42: Power consumption of a RECO configuration

13 Accessories

13.1 Cables and Connectors

The following parts are available for building INTERBUS network connections. Using INDRAMAT cables is not absolutely necessary. The cables from Messrs Phoenix Contact, Blomberg that are listed below may also be used.

Order number	Mating connector of the unit	INDRAMAT cable	Cable end
<p>IKS0056/000,0 MN: 255 968 (INTERBUS, max. 400 m)</p>	 <p>INS525 9-way/male</p>	 <p>INK234</p>	 <p>INS526 9-way/female</p>
<p>INS0525 MN: 259 762</p>	 <p>INS0525/9-way/male</p>	<p>Connector for building an INTERBUS cable with third-party cables.</p>	
<p>INS0526 MN: 259 762</p>	 <p>INS0526/9-way/female</p>	<p>Connector for building an INTERBUS cable with third-party cables.</p>	
<p>Phoenix cable IBS RBC Meter/F-T Part no.: 2723123</p>	<p>Recommendation: Phoenix Contact remote bus cable (cannot be ordered from INDRAMAT)</p>		
<p>Phoenix cable IBS INBC Meter/S Part no.: 2759870</p>	<p>Recommendation: Phoenix Contact installation remote bus cable (cannot be ordered from INDRAMAT)</p>		

Figure 13-43: RECO12.2 accessories

13.2 Additional Annotation

A transparent carrier sheet that is glued to a side of the module can be used to provide the individual RECO I/O modules with additional annotations. This foil can be glued to the left-hand or to the right-hand side of the module housing. The carrier sheets are provided with an adhesive surface. The sheet is intended to accommodate the prepunched stickers that come in quantities of six on an A4 foil.

The relatively moisture-insensitive stickers can be printed on in a standard laser printer. A word processing program is available that makes annotation easier. This program is a Word 7.0 template for Windows NT that permits 1 through 6 modules per sticker to be labelled. It can be selected whether it is a 16-bit, or 32-bit, an input or an output module, and whether the sticker shall be glued to the right-hand or to the left-hand side of the module.

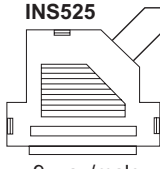
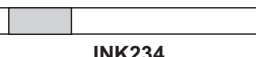
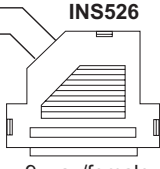
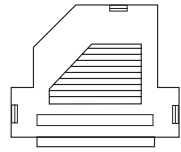
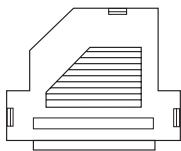
Designation	Type	Material no.
Carrier sheet	RECO annotation film	281 697
Annotation film	RECO annotation film DIN A4 white	281 696
Annotation software	SWD-RECO**-STP-01VRS-MS-C1,44-WIN-NT	281 691

Figure 13-44: Annotation accessories

14 Figures

Figure 1-1: Brief overview of RECO12.2	1-1
Figure 1-2: Mounting dimensions of the RECO12.2 unit	1-3
Figure 1-3: RMB12.2-02 base rack	1-4
Figure 1-4: RMB12.2-02 base rack in connection with RMB12.2-04	1-4
Figure 1-5: RMB12.2-04 base rack	1-5
Figure 2-6: Typical address selection for an output module	2-2
Figure 2-7: Bit, byte, word, and long word addresses for input modules	2-2
Figure 2-8: Bit, byte, word, and long word addresses for output modules	2-3
Figure 3-9: Mounting dimensions of RMK12.2-IBS-BKL	3-1
Figure 3-10: Pin assignments of mains connection and alarm	3-2
Figure 3-11: Pin assignments of the INTERBUS interface	3-2
Figure 4-12: Mounting dimensions of RME12.2-16-DC024	4-1
Figure 4-13: Wiring diagram of RME12.2-16-DC024	4-2
Figure 5-14: Mounting dimensions of RME12.2-32-DC024	5-1
Figure 5-15: Wiring diagram of RME12.2-32-DC024	5-2
Figure 6-16: Mounting dimensions of RME12.2-16-AC115	6-1
Figure 6-17: Wiring diagram of RME12.2-16-AC115	6-2
Figure 7-18: Mounting dimensions of RMA12.2-16-DC024-200	7-1
Figure 7-19: Wiring diagram of RMA12.2-16-DC024-200	7-2
Figure 8-20: Mounting dimensions of RMA12.2-32-DC024-050	8-1
Figure 8-21: Wiring diagram of RMA12.2-32-DC024-050	8-2
Figure 9-22: Mounting dimensions of RMA12.2-16-AC230-200	9-1
Figure 9-23: Wiring diagram of RMA12.2-16-AC230-200	9-2
Figure 10-24: Mounting dimensions of RMA12.2-16-RE230-200	10-1
Figure 10-25: Load-related output rating	10-2
Figure 10-26: Wiring diagram of RMA12.2-16-RE230-200	10-2
Figure 11-27: Block diagram	11-1
Figure 11-28: Dimensions of RMC12.2-2E-1A	11-2
Figure 11-29: Representation of the input channels 1 and 2	11-4
Figure 11-30: Representation of the OUT 0 output word	11-4
Figure 11-31: Representation of the OUT 1 parameter word	11-5
Figure 11-32: Overview of the selectable measuring ranges	11-5
Figure 11-33: Register structure	11-5
Figure 11-34: Analog input connectors X1, X2	11-6
Figure 11-35: Analog output connector X3	11-6
Figure 11-36: Typical wiring of voltage output	11-7
Figure 11-37: Typical wiring of voltage measurement	11-7
Figure 11-38: Typical wiring of current output	11-8
Figure 11-39: Typical wiring of current measurement	11-8
Figure 11-40: Typical connections for temperature measurement using Pt100 element	11-8
Figure 12-41: Maximum number of outputs that can be switched simultaneously.	12-1
Figure 12-42: Power consumption of a RECO configuration	12-2
Figure 13-43: RECO12.2 accessories	13-1
Figure 13-44: Annotation accessories	13-2

Sales & Service Facilities

Germany

Vertriebsgebiet Mitte Germany Centre <input checked="" type="checkbox"/> V/S <input checked="" type="checkbox"/> Service	Vertriebsgebiet Ost Germany East <input checked="" type="checkbox"/> V/S <input checked="" type="checkbox"/> Service	Vertriebsgebiet West Germany West <input checked="" type="checkbox"/> V/S <input checked="" type="checkbox"/> Service	Vertriebsgebiet Nord Germany North <input checked="" type="checkbox"/> V/S <input type="checkbox"/> Service
INDRAMAT GmbH Bgm.-Dr.-Nebel-Str. 2 D - 97816 Lohr am Main Phone: +49 (0)9352/40-0 Fax: +49 (0)9352/40-4885	INDRAMAT GmbH Beckerstraße 31 D - 09120 Chemnitz Phone: +49 (0)371/35 55-0 Fax: +49 (0)371/35 55-333	INDRAMAT GmbH Harkortstraße 25 D - 40849 Ratingen Phone: +49 (0)2102/43 18-0 Fax: +49 (0)2102/41 315	INDRAMAT GmbH Kieler Straße 212 D - 22525 Hamburg Phone: +49 (0)40/85 31 57-0 Fax: +49 (0)40/85 31 57-15
Vertriebsgebiet Süd Germany South <input checked="" type="checkbox"/> V/S <input type="checkbox"/> Service	Gebiet Südwest Germany South-West <input checked="" type="checkbox"/> V/S <input checked="" type="checkbox"/> Service		INDRAMAT Service-Hotline INDRAMAT GmbH Phone: +49 (0)172/660 04 06 or Phone: +49 (0)171/333 88 26
INDRAMAT GmbH Ridlerstraße 75 D-80339 München Phone: +49 (0)89/540138-30 Fax: +49 (0)89/540138-10	INDRAMAT GmbH Böblinger Straße 25 D-71229 Leonberg Phone: +49 (0)7152/9 72-6 Fax: +49 (0)7152/9 72-727		

Service agencies in Germany

Europe

<p>Austria <input checked="" type="checkbox"/> V/S <input type="checkbox"/> Service</p> <p>Mannesmann Rexroth Ges.m.b.H. Geschäftsbereich INDRAMAT Hägelingasse 3 A - 1140 Wien Phone: +43 (0)1/9852540-400 Fax: +43 (0)1/9852540-93</p>	<p>Austria <input type="checkbox"/> V/S <input checked="" type="checkbox"/> Service</p> <p>Mannesmann Rexroth G.m.b.H. Geschäftsbereich INDRAMAT Industriepark 18 A - 4061 Pasching Phone: +43 (0)7221/605-0 Fax: +43 (0)7221/605-21</p>	<p>Belgium <input checked="" type="checkbox"/> V/S <input checked="" type="checkbox"/> Service</p> <p>Mannesmann Rexroth N.V.-S.A. Geschäftsbereich INDRAMAT Industrielaan 8 B-1740 Ternat Phone: +32 (0)2/5823180 Fax: +32 (0)2/5824310</p>	<p>Denmark <input checked="" type="checkbox"/> V/S <input checked="" type="checkbox"/> Service</p> <p>BEC AS Zinkvej 6 DK-8900 Randers Phone: +45 (0)87/11 90 60 Fax: +45 (0)87/11 90 61</p>
<p>United Kingdom <input checked="" type="checkbox"/> V/S <input checked="" type="checkbox"/> Service</p> <p>Mannesmann Rexroth Ltd. INDRAMAT Division 4 Esland Place, Love Lane GB - Cirencester, Glos GL7 1YG Phone: +44 (0)1285/658671 Fax: +44 (0)1285/654991</p>	<p>Finland <input checked="" type="checkbox"/> V/S <input type="checkbox"/> Service</p> <p>Rexroth Mecman OY Ansatie 6 SF-017 40 Vantaa Phone: +358 (0)9/84 91 11 Fax: +358 (0)9/84 91 13 60</p>	<p>France <input checked="" type="checkbox"/> V/S <input checked="" type="checkbox"/> Service</p> <p>Mannesmann Rexroth S.A. Division INDRAMAT Parc des Barbanniers 4, Place du Village F-92632 Gennevilliers Cedex Phone: +33 (0)141 47 54 30 Fax: +33 (0)147 94 69 41 Hotline: +33 (0)6 08 33 43 28</p>	<p>France <input checked="" type="checkbox"/> V/S <input type="checkbox"/> Service</p> <p>Mannesmann Rexroth S.A. Division INDRAMAT 270, Avenue de Lardenne F - 31100 Toulouse Phone: +33 (0)5 61 49 95 19 Fax: +33 (0)5 61 31 00 41</p>
<p>France <input checked="" type="checkbox"/> V/S <input type="checkbox"/> Service</p> <p>Mannesmann Rexroth S.A. Division INDRAMAT 91, Bd. Irène Joliot-Curie F - 69634 Vénissieux Cedex Phone: +33 (0)4 78 78 53 65 Fax: +33 (0)4 78 78 52 53</p>	<p>Italy <input checked="" type="checkbox"/> V/S <input checked="" type="checkbox"/> Service</p> <p>Mannesmann Rexroth S.p.A. Divisione INDRAMAT Via G. Di Vittoria, 1 I - 20063 Cernusco S/N.MI Phone: +39 (0)2/92 36 52 70 Fax: +39 (0)2/92 36 55 12</p>	<p>Italy <input checked="" type="checkbox"/> V/S <input checked="" type="checkbox"/> Service</p> <p>Mannesmann Rexroth S.p.A. Divisione INDRAMAT Via Borgomanero, 11 I - 10145 Torino Phone: +39 (0)11/7 71 22 30 Fax: +39 (0)11/7 71 01 90</p>	<p>Italy <input checked="" type="checkbox"/> V/S <input type="checkbox"/> Service</p> <p>Mannesmann Rexroth S.p.A. Divisione INDRAMAT Via del Progresso, 16 (Zona Ind.) I - 35020 Padova Phone: +39 (0)49/8 70 13 70 Fax: +39 (0)49/8 70 13 77</p>
<p>Italy <input type="checkbox"/> V/S <input checked="" type="checkbox"/> Service</p> <p>Mannesmann Rexroth S.p.A. Divisione INDRAMAT Via de Nicola, 12 I - 80053 Castellamare di Stabia NA Phone: +39 (0)81/8 72 30 37 Fax: +39 (0)81/8 72 30 18</p>	<p>Italy <input checked="" type="checkbox"/> V/S <input type="checkbox"/> Service</p> <p>Mannesmann Rexroth S.p.A. Divisione INDRAMAT Viale Oriani, 38/A I - 40137 Bologna Phone: +39 (0)51/34 14 14 Fax: +39 (0)51/34 14 22</p>	<p>Netherlands <input checked="" type="checkbox"/> V/S <input type="checkbox"/> Service</p> <p>Hydraudyne Hydrauliek B.V. Kruisbroeksestraat 1 P.O. Box 32 NL - 5281 RV Boxtel Phone: +31 (0)411/65 19 51 Fax: +31 (0)411/65 14 83</p>	<p>Netherlands <input type="checkbox"/> V/S <input checked="" type="checkbox"/> Service</p> <p>Hydrocare B.V. Kruisbroeksestraat 1 P.O. Box 32 NL - 5281 RV Boxtel Phone: +31 (0)411/65 19 51 Fax: +31 (0)411/67 78 14</p>
<p>Spain <input checked="" type="checkbox"/> V/S <input checked="" type="checkbox"/> Service</p> <p>Mannesmann Rexroth S.A. División INDRAMAT Centro Industrial Santiga Obradors s/n E-08130 Santa Perpetua de Mogoda Barcelona Phone: +34 937 47 94 00 Fax: +34 937 47 94 01</p>	<p>Spain <input checked="" type="checkbox"/> V/S <input checked="" type="checkbox"/> Service</p> <p>Goimendi S.A. División Indramat Jolastokieta (Herrera) Apartado 11 37 E - 20017 San Sebastian Phone: +34 9 43/40 01 63 Fax: +34 9 43/39 17 99</p>	<p>Sweden <input checked="" type="checkbox"/> V/S <input checked="" type="checkbox"/> Service</p> <p>Rexroth Mecman Svenska AB INDRAMAT Division Varuvägen 7 S - 125 81 Stockholm Phone: +46 (0)8/727 92 00 Fax: +46 (0)8/64 73 277</p>	<p>Switzerland - East <input checked="" type="checkbox"/> V/S <input checked="" type="checkbox"/> Service</p> <p>Mannesmann Rexroth AG Geschäftsbereich INDRAMAT Gewerbstraße 3 CH-8500 Frauenfeld Phone: +41 (0)52/720 21 00 Fax: +41 (0)52/720 21 11</p>
<p>Switzerland - West <input checked="" type="checkbox"/> V/S <input type="checkbox"/> Service</p> <p>Mannesmann Rexroth SA Département INDRAMAT Chemin de l'Ecole 6 CH-1036 Sullens Phone: +41 (0)21/731 43 77 Fax: +41 (0)21/731 46 78</p>	<p>Russia <input type="checkbox"/> V/S <input checked="" type="checkbox"/> Service</p> <p>Tschudnenko E.B. Arsenia 22 RUS - 153000 Ivanovo Rußland Phone: +7 093/223 96 33 or +7 093/223 95 48 Fax: +7 093/223 46 01</p>	<p>Slovenia <input checked="" type="checkbox"/> V/S <input checked="" type="checkbox"/> Service</p> <p>DOMEL Elektromotorji in gospodinjiski aparati d. d. Otoki 21 SLO - 64 228 Zelezniki Phone: +386 64/61 73 32 Fax: +386 64/64 71 50</p>	<p>Turkey <input checked="" type="checkbox"/> V/S <input checked="" type="checkbox"/> Service</p> <p>Mannesmann Rexroth Hidropar A..S. Fevzi Cakmak Cad No. 3 TR - 34630 Sefaköy Istanbul Phone: +90 212/541 60 70 Fax: +90 212/599 34 07</p>

European Service agencies (without Germany)

Outside Europe

<p>Argentina <input checked="" type="checkbox"/> V/S <input type="checkbox"/> Service</p> <p>Mannesmann Rexroth S.A.I.C. Division INDRAMAT Acassuso 48 41/7 RA - 1605 Munro (Buenos Aires)</p> <p>Phone: +54 (0)1/756 01 40 +54 (0)1/756 01 36</p>	<p>Argentina <input type="checkbox"/> V/S <input checked="" type="checkbox"/> Service</p> <p>NAKASE Asesoramiento Tecnico Calle 49, No. 5764-66 RA - 1653 Villa Balester Provincia de Buenos Aires</p> <p>Phone: +54 (0) 1/768 24 13 Fax: +54 (0) 1/768 36 43</p>	<p>Australia <input checked="" type="checkbox"/> V/S <input checked="" type="checkbox"/> Service</p> <p>AIMS - Australian Industrial Machinery Services Pty. Ltd. Unit 3/45 Horne ST Campbellfield 3061 AUS - Melbourne, VIC</p> <p>Phone: +61 (0)3/93 59 02 28 Fax: +61 (0)3/93 59 02 86</p>	<p>Brazil <input checked="" type="checkbox"/> V/S <input checked="" type="checkbox"/> Service</p> <p>Mannesmann Rexroth Automação Ltda. Divisão INDRAMAT Rua Georg Rexroth, 609 Vila Padre Anchieta BR - 09951-270 Diadema-SP [Caixa Postal 377] [BR-09901-970 Diadema-SP]</p> <p>Phone: +55 (0)11/745 90 60 +55 (0)11/745 90 70 Fax: +55 (0)11/745 90 50</p>
<p>Canada <input checked="" type="checkbox"/> V/S <input checked="" type="checkbox"/> Service</p> <p>Basic Technologies Corporation Burlington Division 3426 Mainway Drive Burlington, Ontario Canada L7M 1A8</p> <p>Phone: +1 905/335 55 11 Fax: +1 905/335-41 84</p>	<p>China <input checked="" type="checkbox"/> V/S <input type="checkbox"/> Service</p> <p>Mannesmann Rexroth (China) Ltd. Shanghai Office - Room 206 Shanghai Internat. Trade Centre 2200 Yanan Xi Lu PRC - Shanghai 200335</p> <p>Phone: +86 21/62 75 53 33 Fax: +86 21/62 75 56 66</p>	<p>China <input type="checkbox"/> V/S <input checked="" type="checkbox"/> Service</p> <p>Mannesmann Rexroth (China) Ltd. Shanghai Parts & Service Center 199 Wu Cao Road, Hua Cao Minhang District PRC - Shanghai 201 103</p> <p>Phone: +86 21/62 20 00 58 Fax: +86 21/62 20 00 68</p>	<p>China <input checked="" type="checkbox"/> V/S <input type="checkbox"/> Service</p> <p>Mannesmann Rexroth (China) Ltd. 15/F China World Trade Center 1, Jianguomenwai Avenue PRC - Beijing 100004</p> <p>Phone: +86 10/65 05 03 80 Fax: +86 10/65 05 03 79</p>
<p>China <input checked="" type="checkbox"/> V/S <input type="checkbox"/> Service</p> <p>Mannesmann Rexroth (China) Ltd. A-5F., 123 Lian Shan Street Sha He Kou District PRC - Dalian 116 023</p> <p>Phone: +86 411/46 78 930 Fax: +86 411/46 78 932</p>	<p>Hong Kong <input checked="" type="checkbox"/></p> <p>V/S <input checked="" type="checkbox"/> Service</p> <p>Rexroth (China) Ltd. 19 Cheung Shun Street 1st Floor, Cheung Sha Wan, Kowloon, Hong Kong</p> <p>Phone: +852 27/41 13 51/-54 oder/or +852 27/41 14 30 Fax: +852 27/86 07 33</p>	<p>India <input checked="" type="checkbox"/> V/S <input checked="" type="checkbox"/> Service</p> <p>Mannesmann Rexroth (India) Ltd. INDRAMAT Division Plot. 96, Phase III Peenya Industrial Area IND - Bangalore - 560058</p> <p>Phone: +91 (0)80/8 39 21 01 Fax: +91 (0)80/8 39 43 45</p>	<p>India <input checked="" type="checkbox"/> V/S <input checked="" type="checkbox"/> Service</p> <p>Mannesmann Rexroth (India) Ltd. INDRAMAT Division Plot. A-58, TTC Industrial Area Thane Turbhe Midc Road Mahape Village IND - Navi Mumbai - 400 701</p> <p>Phone: +91 (0)22/7 61 46 22 Fax: +91 (0)22/7 68 15 31</p>
<p>Indonesia <input checked="" type="checkbox"/> V/S <input type="checkbox"/> Service</p> <p>PT. Rexroth Wijayakusuma Jl. Raya Bekasi Km 21 Pulogadung RI - Jakarta Timur 13920</p> <p>Phone: +62 21/4 61 04 87 +62 21/4 61 04 88 Fax: +62 21/4 60 01 52</p>	<p>Japan <input checked="" type="checkbox"/> V/S <input checked="" type="checkbox"/> Service</p> <p>Rexroth Automation Co., Ltd. INDRAMAT Division 1F, I.R. Building Nakamachidai 4-26-44 Tsuzuki-ku, Yokohama-shi J - Kanagawa-ken 224-004</p> <p>Phone: +81 459/42-72 10 Fax: +81 459/42-03 41</p>	<p>Korea <input checked="" type="checkbox"/> V/S <input checked="" type="checkbox"/> Service</p> <p>Mannesmann Rexroth-Seki Co Ltd. 1500-12 Da-Dae-Dong ROK - Saha-Ku, Pusan, 604-050</p> <p>Phone: +82 (0)51/2 60 06 18 Fax: +82 (0)51/2 60 06 19</p>	<p>Korea <input checked="" type="checkbox"/> V/S <input checked="" type="checkbox"/> Service</p> <p>Seo Chang Corporation Ltd. Room 903, Jail Building 44-35 Yeouido-Dong Yeoungdeungpo-Ku C.P.O.Box 97 56 ROK - Seoul</p> <p>Phone: +82 (0)2/7 80 82 08 +82 (0)2/7 80 82 09 Fax: +82 (0)2/7 84 54 08</p>
<p>Mexico <input checked="" type="checkbox"/> V/S <input type="checkbox"/> Service</p> <p>Rexroth Mexico S.A. de C.V. Calle Neptuno 72 Unidad Ind. Vallejo MEX - 07700 Mexico, D.F.</p> <p>Phone: +52 5 754 17 11 +52 5 754 36 84 +52 5 754 12 60 Fax: +52 5 754 50 73 +52 5 752 59 43</p>		<p>South Africa <input checked="" type="checkbox"/> V/S <input checked="" type="checkbox"/> Service</p> <p>HYTEC Automation (Pty) Ltd. 28 Banfield Road, Industria North RSA - Maraisburg 1700</p> <p>Phone: +27 (0)11/673 20 80 Fax: +27 (0)11/673 72 69</p>	<p>Taiwan <input checked="" type="checkbox"/> V/S <input type="checkbox"/> Service</p> <p>Rexroth Uchida Co., Ltd. No.1, Tsu Chiang Street Tu Cheng Ind. Estate Taipei Hsien, Taiwan, R.O.C.</p> <p>Phone: +886 2/2 68 13 47 Fax: +886 2/2 68 53 88</p>

Service agencies outside Europe

Outside Europe / USA

<p>USA <input type="checkbox"/> V/S <input type="checkbox"/> Service</p> <p>Mannesmann Rexroth Corporation INDRAMAT Division 5150 Prairie Stone Parkway USA -Hoffman Estates, IL 60192-3707 Phone: +1 847/6 45 36 00 Fax: +1 847/6 45 62 01</p>	<p>USA <input type="checkbox"/> V/S <input type="checkbox"/> Service</p> <p>Mannesmann Rexroth Corporation INDRAMAT Division Central Region Technical Center USA - Auburn Hills, MI 48326 Phone: +1 248/3 93 33 30 Fax: +1 248/3 93 29 06</p>	<p>USA <input type="checkbox"/> V/S <input type="checkbox"/> Service</p> <p>Mannesmann Rexroth Corporation INDRAMAT Division Southeastern Technical Center 3625 Swiftwater Park Drive USA - Suwanee Georgia 30174 Phone: +1 770/9 32 32 00 +1 770/9 32 19 03</p>	<p>USA <input type="checkbox"/> V/S <input type="checkbox"/> Service</p> <p>Mannesmann Rexroth Corporation INDRAMAT Division Northeastern Technical Center 99 Rainbow Road USA - East Granby, Connecticut 06026 Phone: +1 860/8 44 83 77 +1 860/8 44 85 95</p>
<p>USA <input type="checkbox"/> V/S <input type="checkbox"/> Service</p> <p>Mannesmann Rexroth Corporation INDRAMAT Division Charlotte Regional Sales Office 14001 South Lakes Drive USA - Charlotte, North Carolina 28273 Phone: +1 704/5 83 97 62 +1 704/5 83 14 86</p>			

Service agencies outside Europe / USA

Notes

283909

Printed in Germany





Artisan Technology Group is your source for quality new and certified-used/pre-owned equipment

- FAST SHIPPING AND DELIVERY
- TENS OF THOUSANDS OF IN-STOCK ITEMS
- EQUIPMENT DEMOS
- HUNDREDS OF MANUFACTURERS SUPPORTED
- LEASING/MONTHLY RENTALS
- ITAR CERTIFIED SECURE ASSET SOLUTIONS

SERVICE CENTER REPAIRS

Experienced engineers and technicians on staff at our full-service, in-house repair center

*InstraView*SM REMOTE INSPECTION

Remotely inspect equipment before purchasing with our interactive website at www.instraview.com ↗

WE BUY USED EQUIPMENT

Sell your excess, underutilized, and idle used equipment. We also offer credit for buy-backs and trade-ins. www.artisanng.com/WeBuyEquipment ↗

LOOKING FOR MORE INFORMATION?

Visit us on the web at www.artisanng.com ↗ for more information on price quotations, drivers, technical specifications, manuals, and documentation

Contact us: (888) 88-SOURCE | sales@artisanng.com | www.artisanng.com