



Artisan Technology Group is your source for quality new and certified-used/pre-owned equipment

- FAST SHIPPING AND DELIVERY
- TENS OF THOUSANDS OF IN-STOCK ITEMS
- EQUIPMENT DEMOS
- HUNDREDS OF MANUFACTURERS SUPPORTED
- LEASING/MONTHLY RENTALS
- ITAR CERTIFIED SECURE ASSET SOLUTIONS

SERVICE CENTER REPAIRS

Experienced engineers and technicians on staff at our full-service, in-house repair center

*InstraView*SM REMOTE INSPECTION

Remotely inspect equipment before purchasing with our interactive website at www.instraview.com ↗

WE BUY USED EQUIPMENT

Sell your excess, underutilized, and idle used equipment. We also offer credit for buy-backs and trade-ins. www.artisanng.com/WeBuyEquipment ↗

LOOKING FOR MORE INFORMATION?

Visit us on the web at www.artisanng.com ↗ for more information on price quotations, drivers, technical specifications, manuals, and documentation

Contact us: (888) 88-SOURCE | sales@artisanng.com | www.artisanng.com

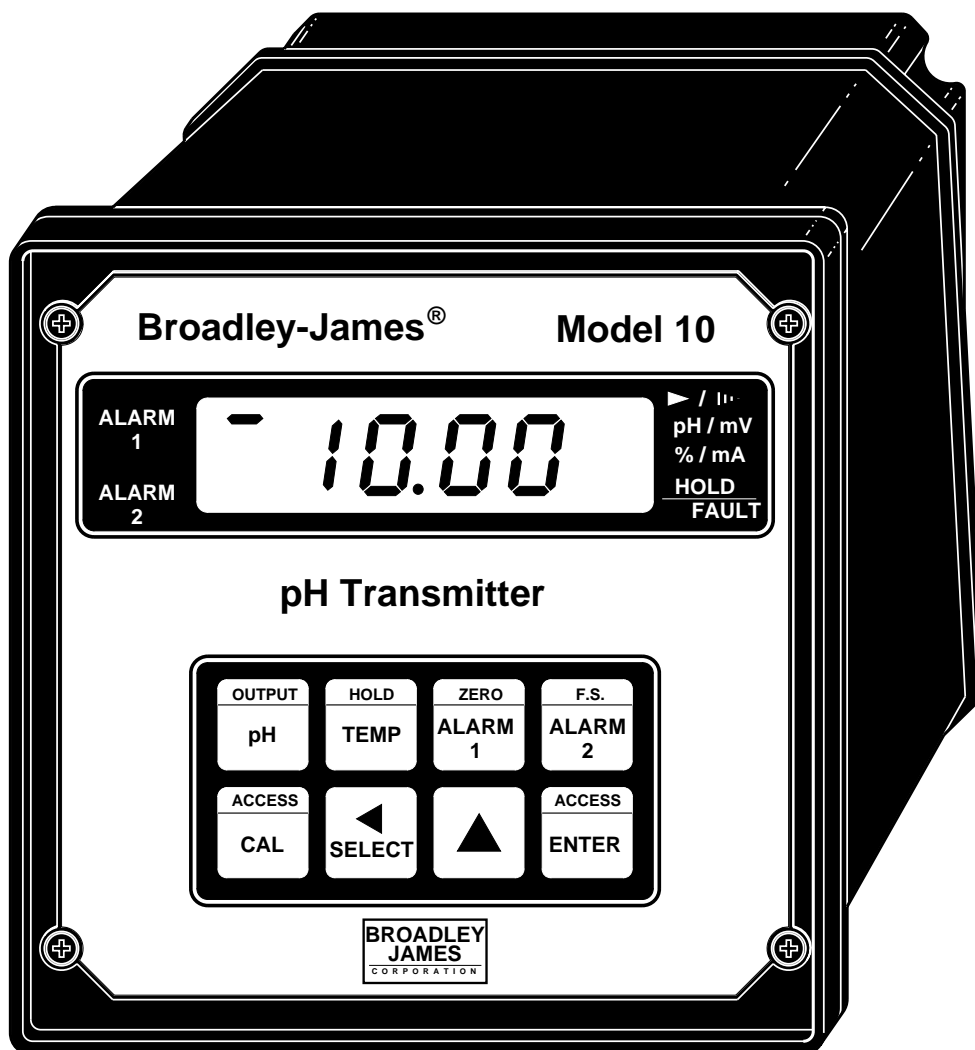

ESSENTIAL INSTRUCTIONS

READ THIS PAGE BEFORE PROCEEDING!

This product has been designed, manufactured, and tested to meet many national and international standards. Because these instruments are sophisticated technical products, you must properly install, use, and maintain them to ensure they continue to operate within their normal specifications. The following instructions must be adhered to and integrated into your safety program when installing, using, and maintaining these products. Failure to follow the proper instructions may cause any one of the following situations to occur: Loss of life; personal injury; property damage; damage to this instrument; and warranty invalidation.

- Read all instructions prior to installing, operating, and servicing the product. If this Instruction Manual is not the correct manual, telephone (714) 829-5555 and the requested manual will be provided. Save this Instruction Manual for future reference.
- If you do not understand any of the instructions, contact your Broadley-James representative for clarification.
- Follow all warnings, cautions, and instructions marked on and supplied with the product.
- Inform and educate your personnel in the proper installation, operation, and maintenance of the product.
- Install your equipment as specified in the Installation Instructions of the appropriate Instruction Manual and per applicable local and national codes. Connect all products to the proper electrical and pressure sources.
- To ensure proper performance, use qualified personnel to install, operate, update, program, and maintain the product.
- When replacement parts are required, ensure that qualified people use replacement parts specified by Broadley-James. Unauthorized parts and procedures can affect the product's performance and place the safe operation of your process at risk. Look alike substitutions may result in fire, electrical hazards, or improper operation.
- Ensure that all equipment doors are closed and protective covers are in place, except when maintenance is being performed by qualified persons, to prevent electrical shock and personal injury.

WARNING

ELECTRICAL SHOCK HAZARD

Making cable connections to and servicing this instrument requires access to shock hazard level voltages which can cause death or serious injury.

Relay contacts made to separate power sources must be disconnected before servicing.

Electrical installation must be in accordance with the National Electrical Code (ANSI/NFPA-70) and/or any other applicable national or local codes.

Unused cable conduit entries must be securely sealed by non-flammable closures to provide enclosure integrity in compliance with personal safety and environmental protection requirements.

For safety and proper performance this instrument must be connected to a properly grounded three-wire power source.

Proper relay use and configuration is the responsibility of the user.

Do not operate this instrument without front cover secured. Refer installation, operation and servicing to qualified personnel.

P1675 REV. B

June 1998

Broadley-James Corporation
19 Thomas
Irvine, CA 92718 USA
Tel: (949) 829-5555



MODEL 10-P-03 MICROPROCESSOR TRANSMITTER

TABLE OF CONTENTS

Section	Title	Page
1.0	DESCRIPTION AND SPECIFICATIONS	6
1.1	Features and Applications.....	6
1.2	Physical Specifications-General.....	7
1.3	Instrument Specifications.....	7
1.4	Recommended Sensors.....	7
2.0	INSTALLATION	8
2.1	General.....	8
2.2	Unpacking and Inspection.....	8
2.3	Mechanical Installation.....	8
2.3.1	Panel Mounting	8
2.3.2	Wall Mounting.....	8
2.3.3	Pipe Mounting.....	8
2.4	Electrical Wiring.....	9
2.4.1	Power Input Wiring.....	9
2.4.2	Output Wiring.....	9
2.4.3	Sensor Wiring.....	9
2.4.4	Preamplifier Wiring.....	9
2.5	EMC Installation Guidelines.....	9
2.5.1	Screening and Earthing.....	17
2.5.2	Summary of EMC Guidelines.....	17
3.0	DESCRIPTION OF CONTROLS.....	18
3.1	Keyboard Functions.....	18
4.0	CONFIGURATION.....	22
4.1	Configuration.....	22
4.2	Alarm 1 and 2	25
4.3	Interval Timer.....	27
4.4	Temperature.....	29
4.5	Current Output.....	31
4.6	pH Electrode Diagnostics.....	33
4.7	Solution Temperature Compensation and Isopotential Point... ..	35
4.8	Defaults.....	37
4.9	Automatic Buffer Mode.....	39
4.10	Alarm Setpoint.....	41
4.11	Output Scale Expansion.....	42
4.12	Simulate Current Output.....	43
5.0	START- UP AND CALIBRATION	44
5.1	Start- Up and Calibration.....	44
5.2	Temperature Calibration	44
5.3	Buffer Calibration.....	44
5.4	pH Standardization.....	45
5.5	pH Glass Slope	45
5.6	Sensor Maintenance.....	45

TABLE OF CONTENTS CONT'D.

Section	Title	Page
6.0	KEYBOARD SECURITY.....	46
6.1	Keyboard Security.....	46
7.0	THEORY OF OPERATION.....	47
7.1	Theory of Operation.....	47
8.0	DIAGNOSTICS AND TROUBLESHOOTING.....	48
8.1	Diagnostics.....	48
8.1.1	Fault Mnemonics.....	48
8.1.2	Temperature Compensation.....	48
8.2	Troubleshooting	49
8.2.1	Installation Failure.....	49
8.2.2	LED Display Test.....	49
8.2.3	Software Version.....	49
8.2.4	Sensor Troubleshooting	49
8.2.5	Electrode Input.....	49
8.2.6	CPU Board Replacement.....	49
8.2.7	Power Board Replacement.....	49
9.0	RETURN OF MATERIALS.....	52
9.1	General.....	52
9.2	Warranty Repair.....	52
9.3	Non Warranty Repair.....	52

LIST OF FIGURES

Figure No.	Title	Page
2-1	Panel Mounting Cutout.....	10
2-2	Panel Mounting Tab Installation.....	11
2-3	Wall Mounting J-Box Installation.....	12
2-4	Wall Mounting J-Box Wiring.....	13
2-5	Pipe Mounting Installation.....	14
2-6	Electrical Wiring.....	15
2-7	Integral Preamp Wiring.....	16
2-8	Cable Separation Guidelines.....	17
3-1	Keyboard Overlay.....	19
4-1	Menu Items.....	23
4-2	Alarms 1 and 2 Configuration.....	26
4-3A	Interval Timer Example.....	27
4-3	Interval Timer Configuration.....	28
4-4	Temperature Configuration.....	30
4-5	Current Output Configuration.....	32
4-6	pH Electrode Diagnostics Configuration.....	34

LIST OF FIGURES CONT'D.

4-7	Solution Temperature Compensation & Isopotential Point Configuration.....	36
4-8	Default State Configuration.....	38
4-9	Automatic Buffer Mode Configuration.....	40
4-10	Alarm Setpoint.....	41
4-11	Output Scale Expansion.....	42
4-12	Simulate Current Output.....	43

LIST OF TABLES

Table No.	Title	Page
3-1	Key Description.....	20
3-2	Information Mnemonics.....	21
3-3	Set Function Mnemonics.....	21
4-1	Configuration Work Sheet.....	24
4-2	Relay States For Various Transmitter Conditions & Alarm/Default Config....	37
8-1	Fault Mnemonics.....	48
8-2	RTD Resistance Values.....	48
8-3	Troubleshooting Guide.....	50
8-4	Sensor Input to Transmitter vs. pH at Four Temperatures.....	49
8-5	Replacement Parts and Accessories.....	51
8-6	Ordering Information.....	51
8-7	Accessory Ordering Information.....	51

SECTION 1.0

DESCRIPTION AND SPECIFICATIONS

- *pH ELECTRODE DIAGNOSTICS* warn user of the need for calibration or electrode replacement.
- *AUTOMATIC BUFFER RECOGNITION* with stored buffer-temperature curves.
- *NEMA 4X (IP65) WEATHERPROOF CORROSION-RESISTANT ENCLOSURE.*
- *NO BATTERY BACK-UP REQUIRED. Non-volatile EEPROM memory.*
- *SPECIFIC PROCESS TEMPERATURE COMPENSATION* for pH changes due to temperature.

1.1 FEATURES AND APPLICATIONS

The Model 10-P-03 Microprocessor Transmitter, with the appropriate sensor, is designed to continuously measure and control pH in industrial and municipal processes.

The Model 10-P-03 is housed in a NEMA 4X (IP65) weatherproof corrosion-resistant, flame retardant enclosure suitable for panel, pipe or wall mounting. All functions are accessed through the front panel membrane keyboard which features tactile feedback. Measurement data may be read at any time; however, settings may be protected against accidental or unauthorized changes by a user selectable security code. The display indicates the measured value in engineering units as well as temperature, alarm status, hold output and fault conditions.

The Model 10-P-03 transmits an isolated current output which is continuously expandable over the measurement range for either direct or reverse action. A hold output function is available for allowing manual control during routine sensor maintenance. During hold mode the output will be at a preset or last process value.

In the event of one of the following conditions, the transmitter will drive the output to a preset value in addition to displaying a fault code. Continuous self diagnostics alert the user to the following:

- Broken or cracked electrode
- Worn out or non-immersed electrode
- Calibration or coated electrode warning
- Faulty slope value (off-line only)
- Open wiring
- Transmitter electronics failure
- Faulty temperature element or temperature value

With automatic buffer recognition, the transmitter recognizes the buffers, then calculates the electrode slope using stored pH-temperature curves for ten common buffers.

Dual alarms are a standard feature on the Model 10-P-03 and are programmable for either high or low operation. Alarm 2 may be programmed to activate in event of a failure detected by the continuous diagnostics. Both alarms feature independent setpoints, adjustable hysteresis and time delay action. A dedicated interval timer with relay is also provided for chemical or ultrasonic cleaning.

The Model 10-P-03 automatically compensates the pH reading for process temperature changes. Automatic or manual temperature compensation is keyboard selectable. The process temperature can be read on the display in °F or °C. Additional process temperature compensation is available.

The Transmitter includes a 0.7 inch digital display available in LED format.

1.2 PHYSICAL SPECIFICATIONS - GENERAL

Panel Mount Enclosure: Black, ABS, NEMA 4X, IP65, CSA Enclosure 4.
144 X 144 X 192mm, DIN size.
(5.7 X 5.7 X 7.6 inches).

Front Panel: Membrane keyboard with tactile feedback and user selectable security. Black and white on grey.

Digital Display: Optional, red LED
Character Height: 18mm (0.7 inch)

Electrical Classification:
General Purpose

Power: 115 Vac, ± 10%, 50/60 Hz ± 6%, 4.0 W
230 Vac, ± 10%, 50/60 Hz ± 6%, 4.0 W

EMI / RFI:
EN-50081-2 
EN-50082-2

Current Output: Isolated, 0-20 mA or 4-20 mA into 600 ohms maximum load, Direct or Reverse

Output Dampening: 0-255 seconds.

Ambient Temperature: -10 to 65°C (14 to 149°F)

Ambient Humidity: LED: 0-95% RH

Alarms: Dual, field selectable High/Low, High/High, Low/Low
Alarm 2 configurable as a fault alarm
Time Delay 0 to 255 seconds
Dual Setpoints, continuously adjustable
Hysteresis is adjustable up to 2 pH units
for low side/High Alarm and high side/Low Alarm

Interval Timer: Interval: Minimum 10 minutes
On Counts: 1 to 60
On Duration: 1 to 299 seconds
Off Duration: 1 to 299 seconds
Wait Duration: 1 to 299 seconds
Controls dedicated relay

Relay Contacts: Epoxy Sealed Form A contacts, SPST
Normally Open.

	Resistive	Inductive
28 Vdc	6.0 Amps	3.0 Amps
115 Vac	6.0 Amps	3.0 Amps
230 Vac	6.0 Amps	1.5 Amps

Weight/Shipping Weight: 1.1 kg/1.6 kg (2.5 lbs./3.5 lbs.)

The **Model 10-P-03 Transmitter** requires a preamplifier to convert the high impedance pH glass electrode signal to a low impedance signal. The preamplifier may be located in one of two areas; in a remote junction box for submersion applications and when the distance between the pH sensor and the transmitter is greater than 4.5 meters (15 feet), or in the transmitter when the distance between the pH sensor and the transmitter is 4.5 meters (15 feet) or less. With the remote junction box/preamplifier located as close to the pH sensor as possible, the result is that the pH signal may then be reliably transmitted from the sensor to the transmitter using standard instrument cable.

The Model 10-P-03 measures over the full range of 0-14 pH. The current output may be calibrated to represent any 1 to 14 pH span. A two-point calibration is made by immersing the sensor in two different buffer solutions and entering the pH values. When two buffers are used, the microprocessor automatically calculates the electrode slope which is used for self-diagnostics. This electrode slope can be read on the display and manually adjusted for longer electrode life. A one-point process standardization is easily accomplished by entering the pH value of a grab sample.

1.3 INSTRUMENT SPECIFICATIONS @ 25°C

Measurement Range: 0 to 14 pH
Output Scale Expansion: Zero suppression: up to 13 pH units
Span: Any pH from 1 to 14
Accuracy: ±0.01 pH
Repeatability: ±0.01 pH
Stability: ±0.01 pH/month, non-cumulative
Temperature Coefficient: Input: ±0.003 pH/°C
Output: ±0.006 pH/°C
Temperature Compensation: Pt100 RTD, Automatic or Manual
-15 to 100°C (5 to 212°F)

1.4 RECOMMENDED SENSORS:

All Fermprobe® pH sensors designed for insitu bio/pharmaceutical applications.

All DynaProbe® Industrial Grade Process pH sensors designed for flow-through, submersion, insertion, and valve retraction applications.

SECTION 2.0 INSTALLATION

2.1 GENERAL. This transmitter's enclosure is suitable for outdoor use. However it should be located in an area where temperature extremes, vibrations, electromagnetic and radio frequency interferences are minimized or absent.

2.2 UNPACKING AND INSPECTION. Inspect the transmitter for shipping damage. If damaged, notify the carrier immediately. Confirm that all items shown on the packing list are present. Notify Broadley-James if items are missing.

2.3 MECHANICAL INSTALLATION. Select an installation site that is at least one foot from any high voltage conduit, has easy access for operating personnel, and is not in direct sunlight. Mount the Model 10-P-03 as follows:

1. Remove the four screws that secure the rear cover of the enclosure (not required for wall mount option). The latching hardware for panel and pipe mounting is located inside the rear cover.
2. For standard panel and pipe mounting, remove the four screws holding the front panel assembly of the enclosure and carefully pull the front panel and connected printed circuit boards straight out (not required for wall mount option).
3. Follow the procedure for the appropriate mounting configuration: Section 2.3.1 for panel mounting, Section 2.3.2 for wall mounting, or Section 2.3.3 for pipe mounting.

2.3.1 Panel Mounting (Standard). The Model 10-P-03 transmitter is designed to fit into a DIN standard 137.9 mm X 137.9 mm (5.43 inch X 5.43 inch) panel cutout (refer to Figures 2-1 and 2-2).

1. Prepare the transmitter as described in Section 2.3.
2. Install the mounting latches as shown in Figure 2-2 (latches are shown oversize for clarity). If the latches are not installed exactly as shown, they will not work correctly. The screws provided are self-tapping. Tap the screw the full depth of the mounting latch (refer to side view) leaving a gap greater than the thickness of the cutout panel.
3. Align the latches as shown and insert the transmitter enclosure through the front of the panel cutout. Tighten the screws for a firm fit. To avoid damaging the mounting latches, do not use excessive force.

4. Replace the front panel assembly. Circuit boards must align with the slots on the inside of the enclosure. Replace the door and four front panel screws.

2.3.2 Wall Mounting (Optional). Refer to Figures 2-3 and 2-4. The integral preamp should not be used with this option.

1. Prepare the transmitter as described in Section 2.3.
2. Mount the junction box and bracket to the transmitter with the hardware provided. All wiring can be brought to the terminal strip prior to mounting the transmitter.
3. Place the metal stiffener on the inside of the transmitter and mount the two 0.5 inch conduit fittings using two each weather seals as shown. Mount NEMA 4X conduit plug (included) into center conduit hole.
4. Mount the transmitter to the junction box using the 0.5 inch conduit fittings.
5. Complete wiring from the Model 10-P-03 to the junction box (Figure 2-4).

2.3.3 Pipe Mounting (Optional). The 2" pipe mounting bracket includes a metal plate with a cutout for the Model 10-P-03. Refer to Section 2.3 for mounting the transmitter into the plate. Mounting details are shown in Figure 2-5.

2.4 ELECTRICAL WIRING. The Model 10-P-03 has three conduit openings in the bottom rear of the transmitter housing which will accommodate 0.5 inch conduit fittings. From a back view, the conduit opening on the left is for timer, alarm, and AC connections; the center is for signal output and the opening on the right is for sensor wiring.

Sensor wiring should always be run in a separate conduit from power wiring.

NOTE

Standard panel and optional pipe mounts require installation of the integral preamplifier module. (Refer to Figure 2-7 for installation and wiring.)

NOTE

For best EMI/RFI protection the output cable should be shielded and enclosed in an earth grounded rigid metal conduit. Connect the outer cable shield to earth ground terminal 8 of either TB2 or TB3 when wiring direct to the transmitter, Fig. 2-6.

The sensor cable should also be shielded and in some installations must be run in a rigid metal conduit. When wiring directly to the transmitter, connect the sensor cable's outer shield to the transmitter's earth ground via terminal 8 of TB2. If the sensor cable's outer shield is braid, an appropriate metal cable gland fitting may be used to connect the braid to earth ground via the transmitter case.

2.4.1 Power Input Wiring. The MODEL 10-P-03 can be configured for either 115 Vac or 230 Vac power.

Connect AC power to TB1-8 and -9 (115 VAC) or to TB1-7 and -8 (230 VAC). Connect ground to TB3-8 (refer to Figure 2-6).

CAUTION

The sensitivity and stability of the transmitter will be impaired if the input wiring is not grounded. DO NOT apply power to the transmitter until all electrical connections are verified and secure. The following precautions are a guide using UL 508 as a safeguard for personnel and property.

1. AC connections and grounding must be in compliance with UL 508 and/or local electrical codes.
2. The metal stiffener is required to provide support and proper electrical continuity between conduit fittings.
3. This type 4/4X enclosure requires a conduit hub or equivalent that provides watertight connect, REF UL 508-26.10.
4. Watertight fittings/hubs that comply with the requirements of UL 514B are to be used.
5. Conduit hubs are to be connected to the conduit before the hub is connected to the enclosure, REF UL 508-26.10.
6. If the metal support plate is not used, plastic fittings must be used to prevent structural damage to the enclosure. Also, appropriate grounding lug and AWG conductor must be used with the plastic fittings.

2.4.2 Output Wiring. The alarm connections are made to terminals 1 through 4 of TB1 (refer to Figure 2-6). The current loop output connections are made to TB3-1(+) and TB3-2(-). Timer relay connections are made to TB1-5 and TB1-6.

NOTE

Install weathertight seal P/N AM-9263 in the unused opening.

2.4.3 Preamplifier. For integral preamplifier mounting and wiring information refer to Figures 2-4, 2-7.

2.5 EMC (ELECTROMAGNETIC COMPATIBILITY) INSTALLATION GUIDELINES. The CE mark affixed to an instrument is your guarantee of compliance with all applicable European directives when installed and operated correctly. Please refer to the following installation guidelines and recommended cable separations provided in FIGURE 2-8.

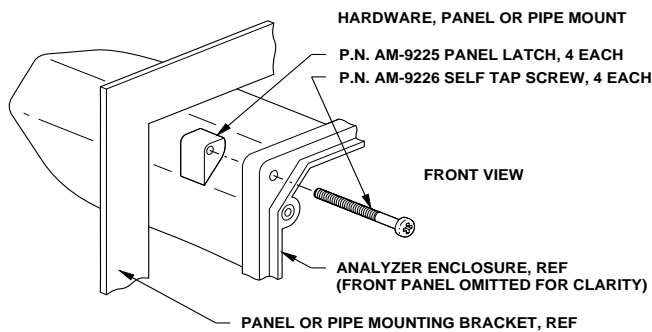
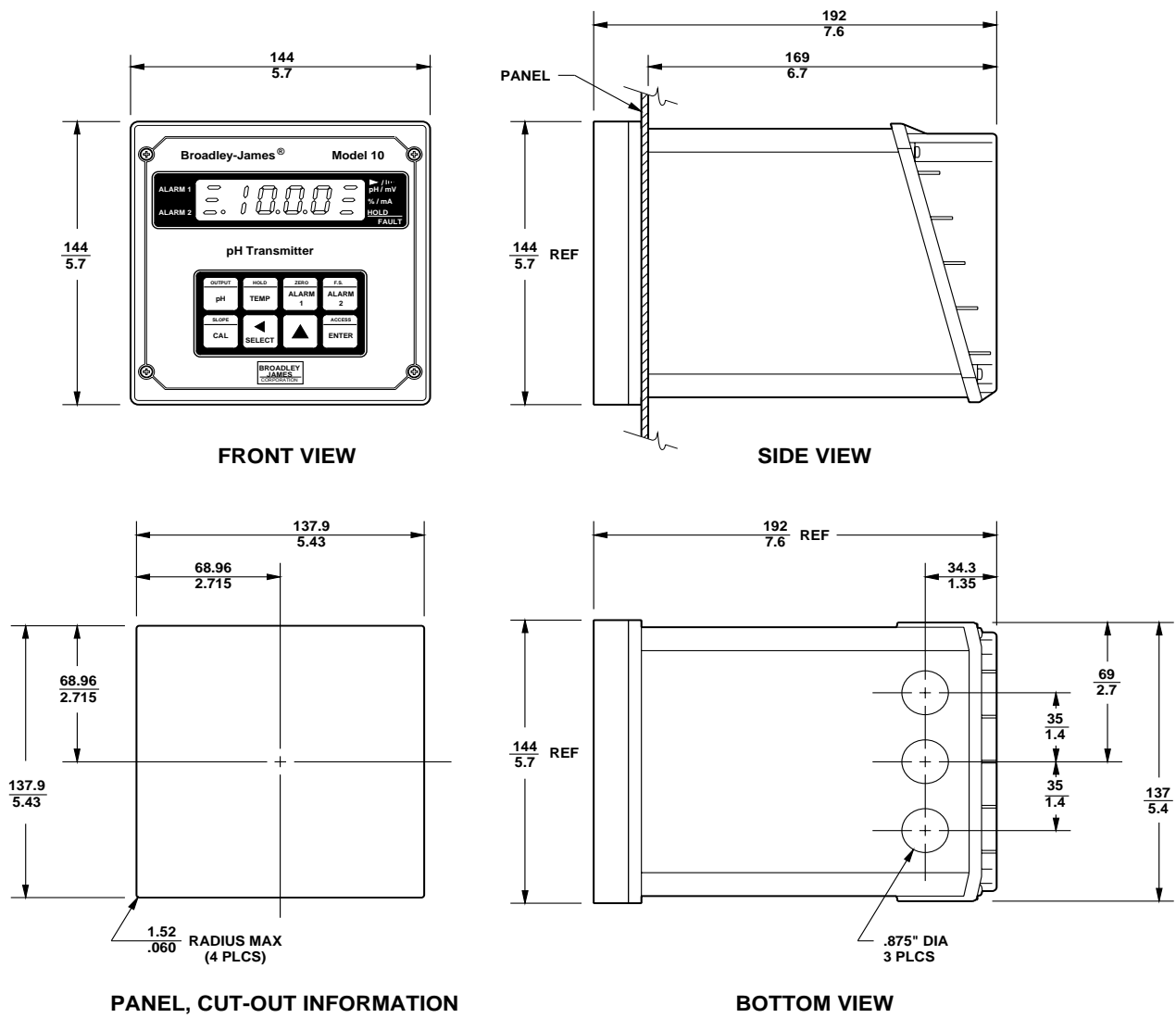

WHEN INCH AND METRIC DIMS ARE GIVEN
 MILLIMETER
 INCH

FIGURE 2-1. Panel Mounting Cutout

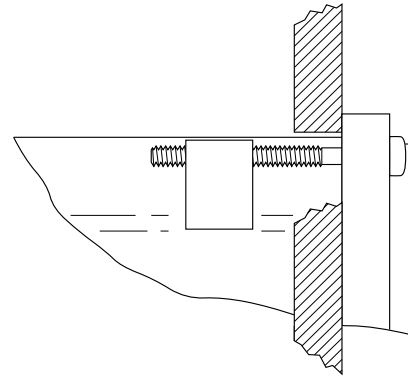

Side View

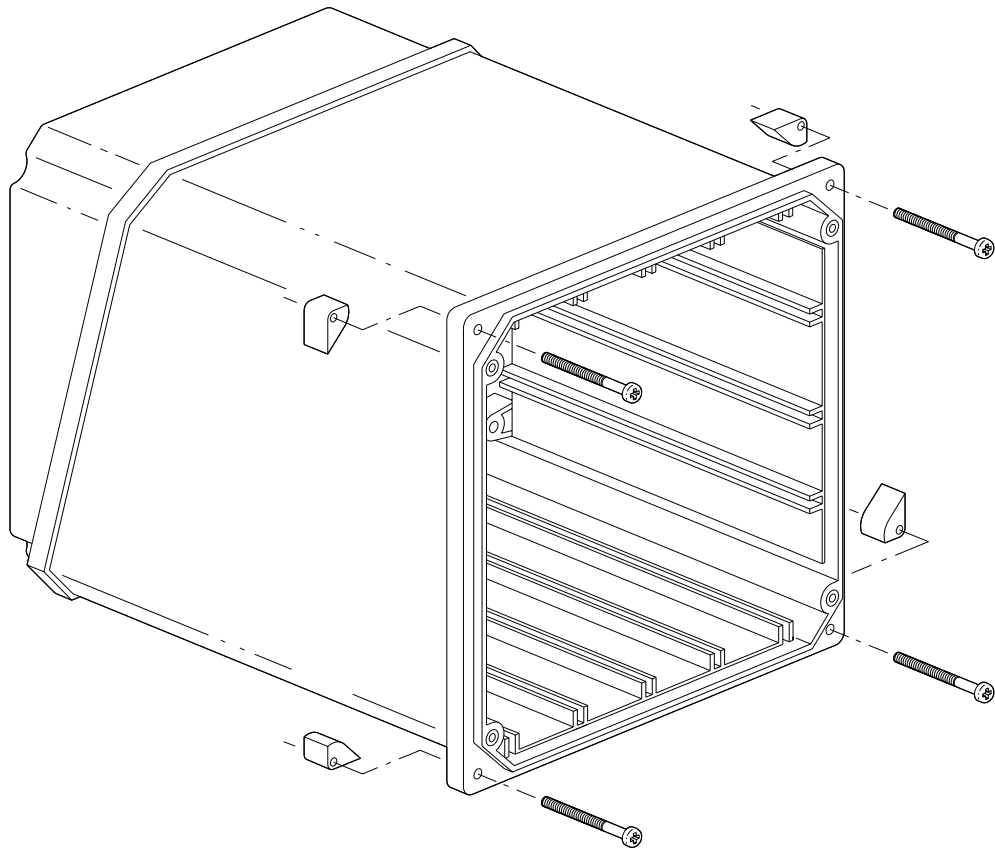
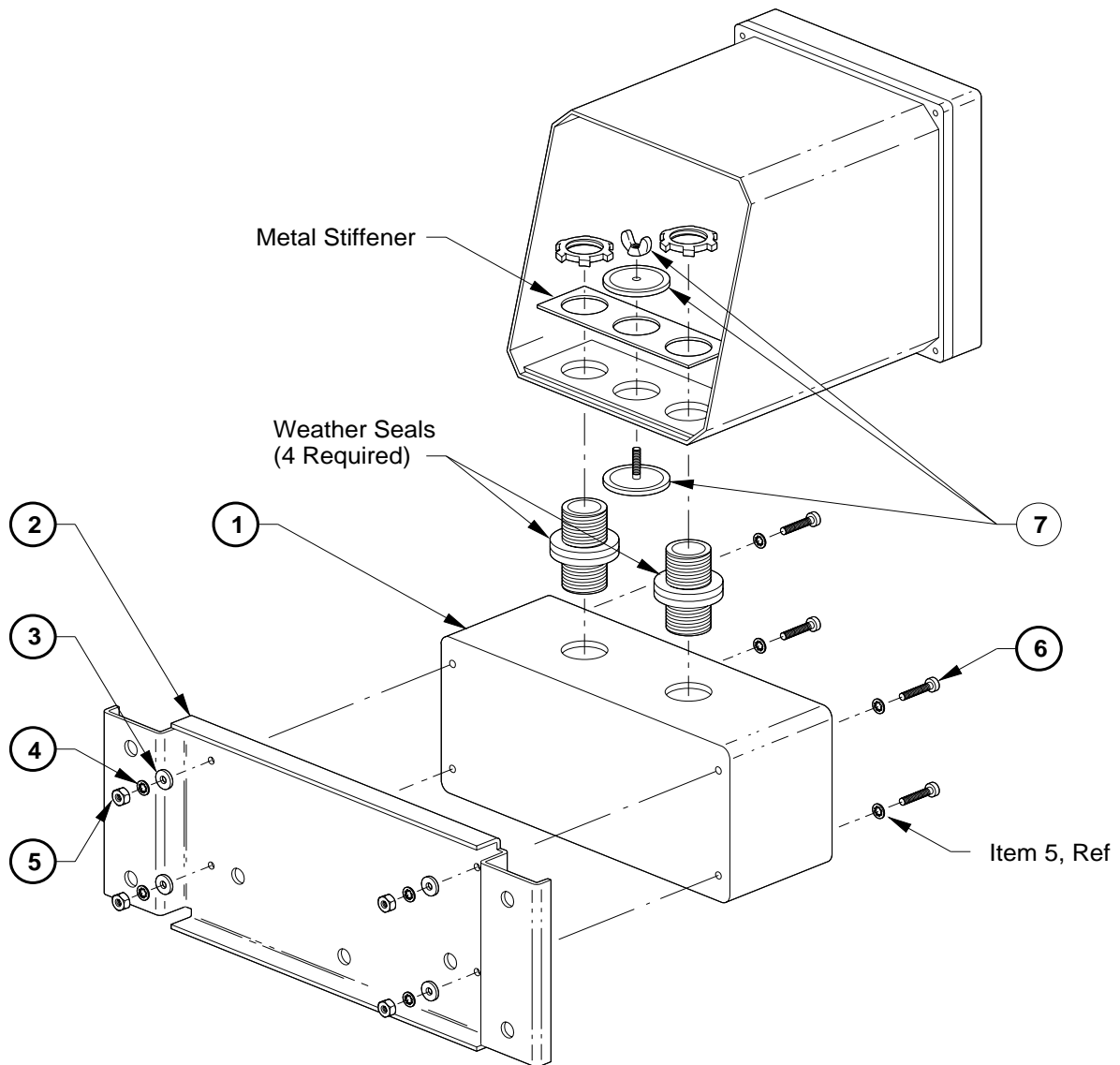

FIGURE 2-2 Panel Mounting Latch Installation



ITEM	PART NUMBER	DESCRIPTION	QTY
1	AM-9241	J-Box Sub-assembly	1
2	AM-9242	Wall Mounting Bracket	1
3	AM-9243	#6 Flat Washer	4
4	AM09244	#6 Internal Lock Washer	4
5	AM-9245	6-32 Hex Nut	8
6	AM-9246	6-32 x .75 Screw	4
7	AM-9247	Weathertight Seal	1

FIGURE 2-3 Wall Mounting J-Box Installation

Broadley-James Corporation

19 Thomas • Irvine CA 92618 USA
Tel: (949) 829-5555 • Fax (949) 829-5560

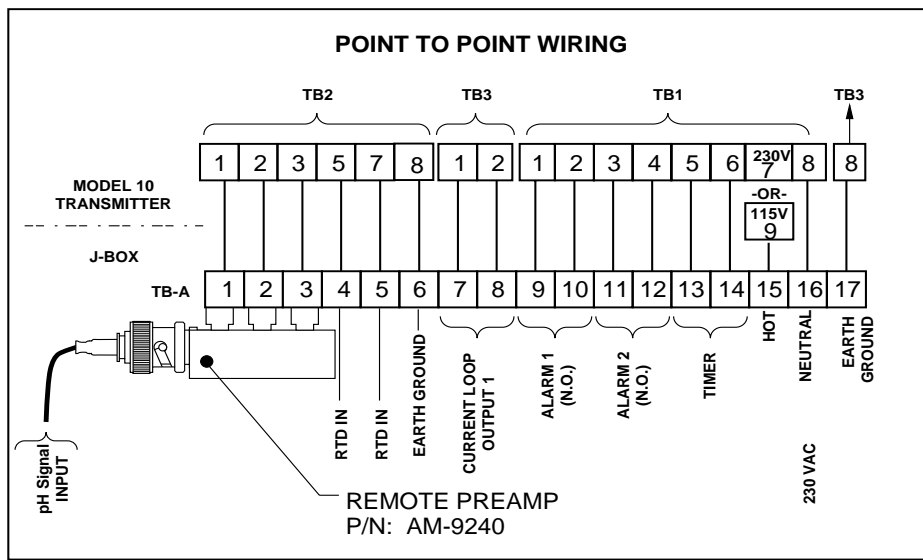
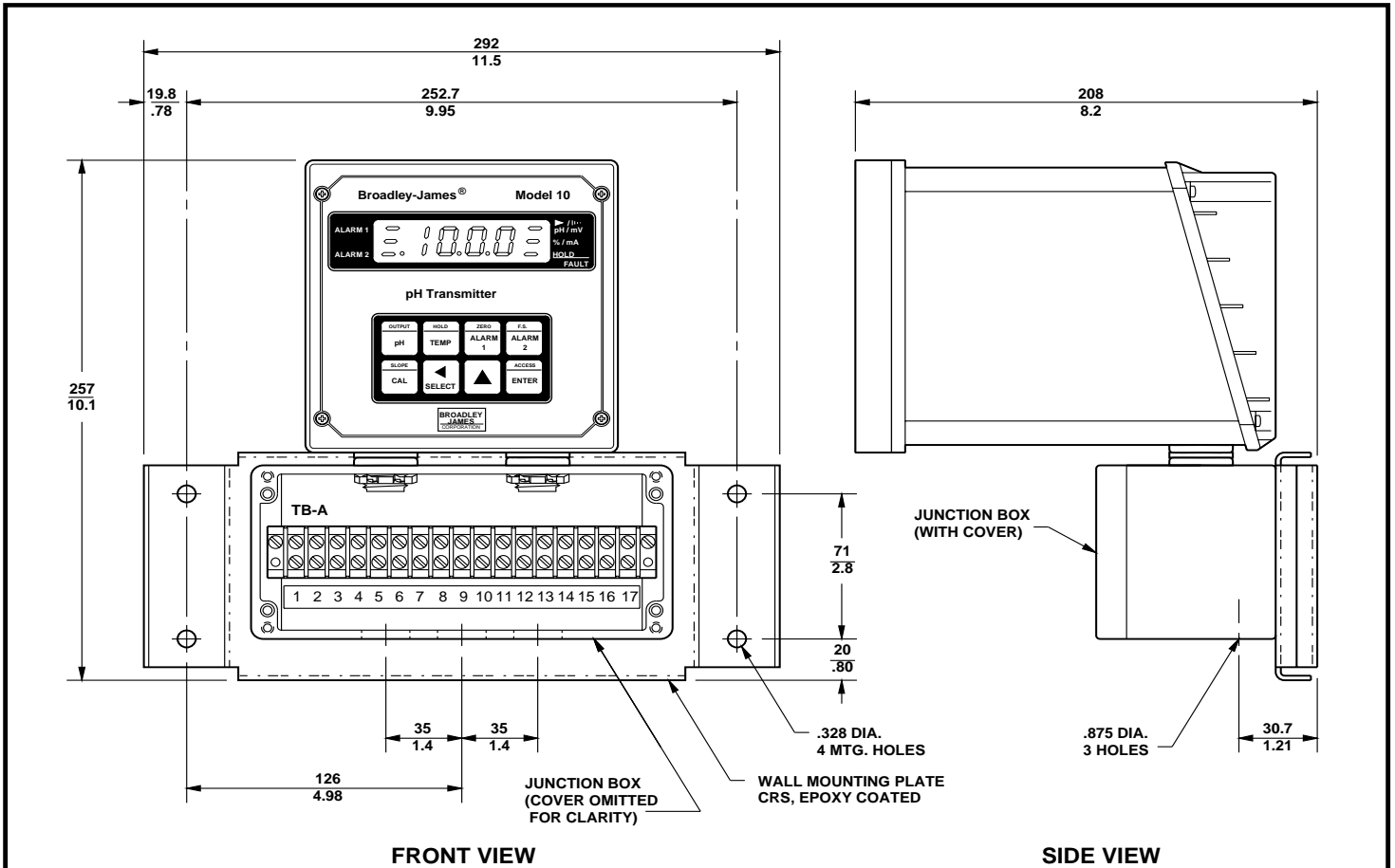
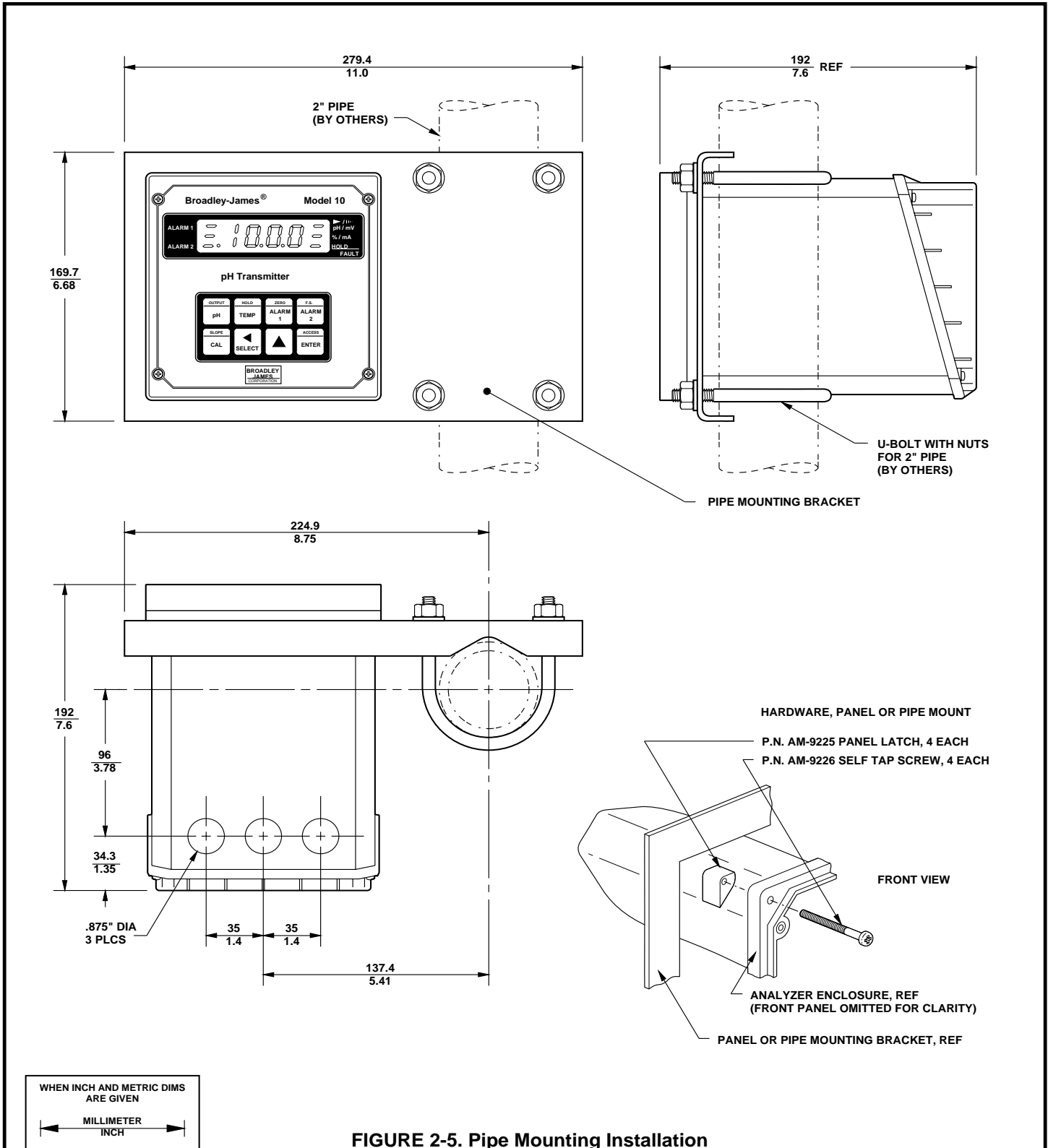
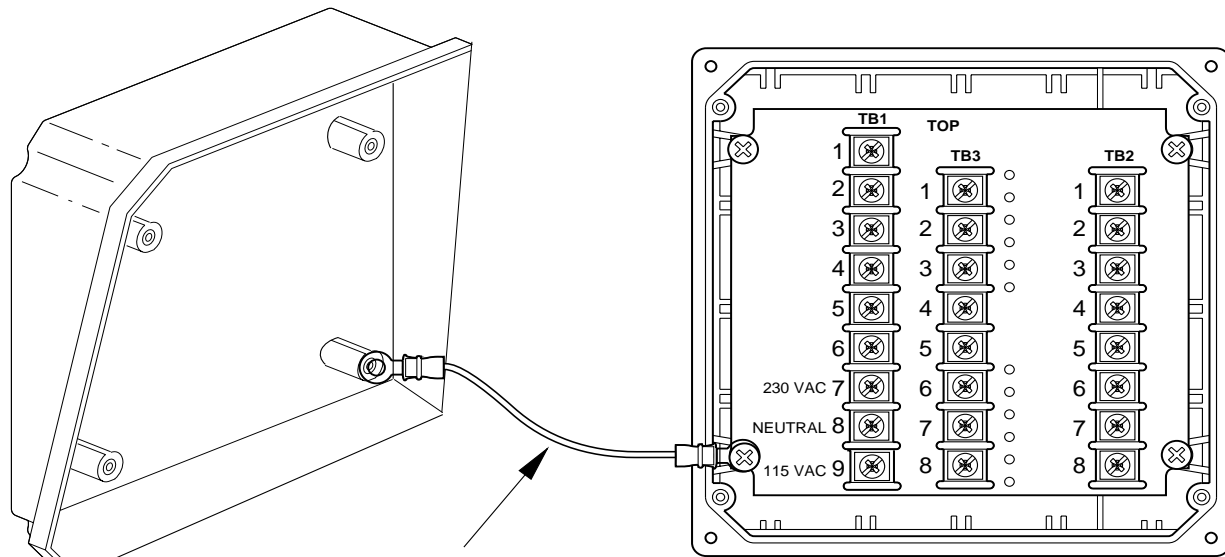

FIGURE 2-4. Wall Mounting J-Box Wiring



Broadley-James Corporation

19 Thomas • Irvine CA 92618 USA
Tel: (949) 829-5555 • Fax (949) 829-5560



EMC Shield Strap
for Enclosure
(Must be connected to rear
cover and Mother Board as
shown for proper operation)

BACK VIEW /COVER OMITTED

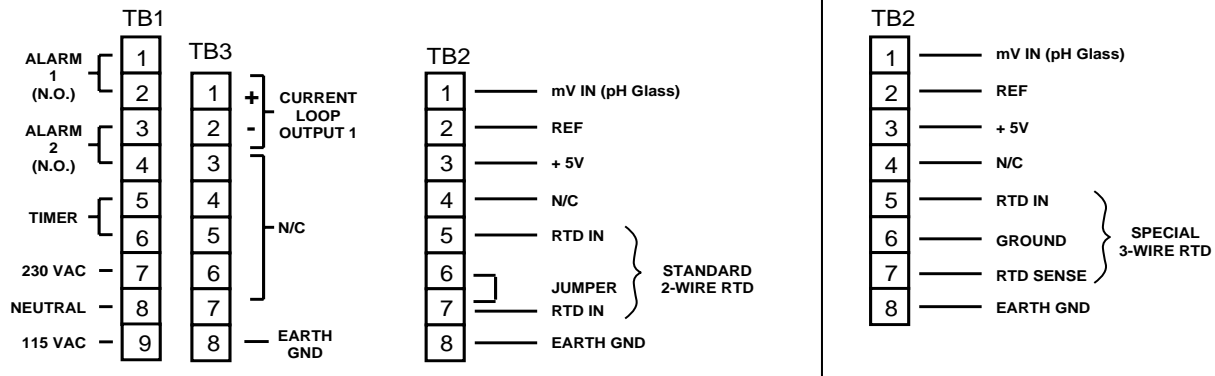

FIELD TERMINAL BOARD CONNECTIONS

FIGURE 2-6. Model 10-P-03 pH Electrical Wiring

MODEL 10-P-03

BACK VIEW /COVER OMITTED

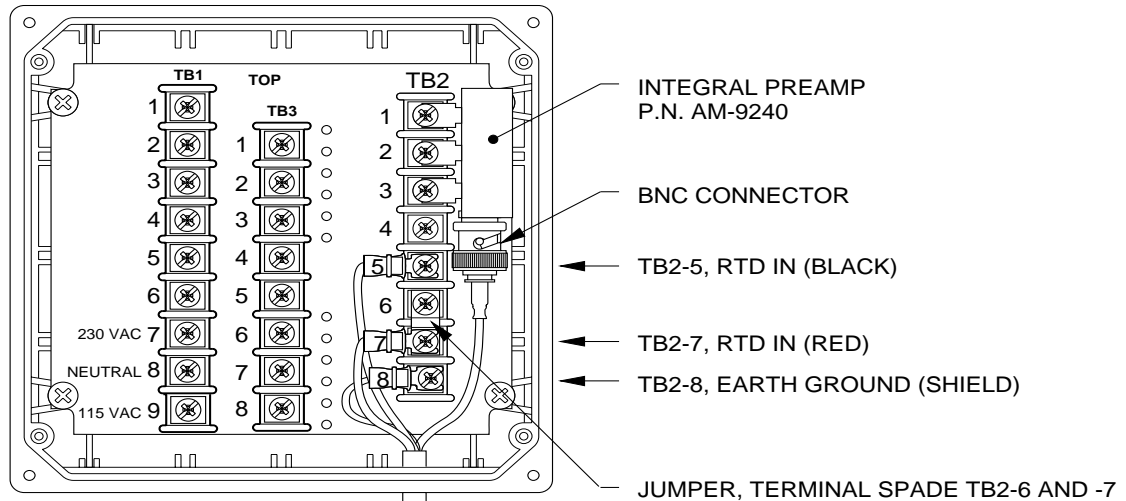

CABLE TO SENSOR

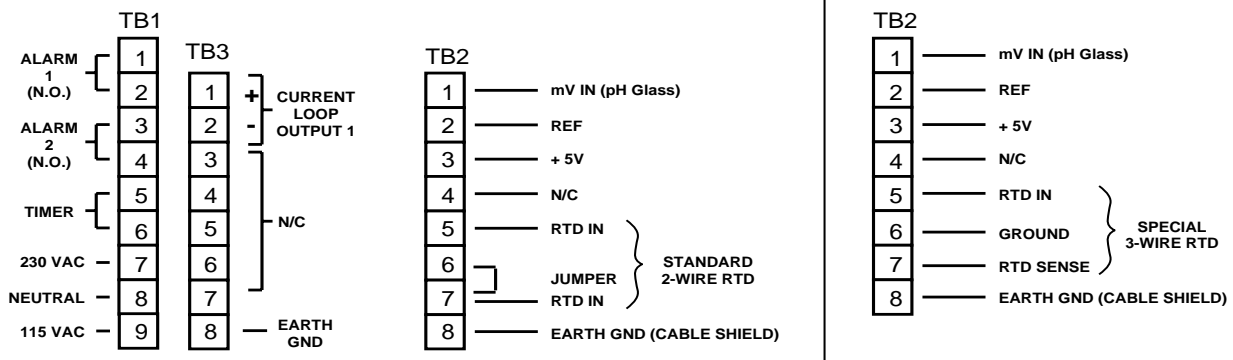

FIELD TERMINAL BOARD CONNECTIONS

FIGURE 2-7. Integral Preamp Wiring for Model 10-P -03

Signal Cable	Power Cable					
	Twin (round) PVC sheathed	Twin & Earth	Earthed conduit	Earthed trunking	Steel wire armoured	MICC
Twin (flat) PVC sheathed	160	145	145	120	105	15
Aluminum foil screened	105	80	30	35	25	15
Twin (round) PVC sheathed	65	90	35	25	20	15
Unscreened twisted pair	60	65	25	25	15	15
Coaxial	20	20	20	15	20	15
Screened twisted pair	15	20	15	15	15	15
Steel wire armoured	15	15	15	15	15	15
MICC	15	15	15	15	15	15
Minimum Cable separation distances in millimeters based on 100 meter parallel cable run and with up to 125 amps flowing in power cable.						

FIGURE 2-8. Recommended Minimum Cable Separation Guidelines

2.5.1 Screening & Earthing. Screen (i.e. shield) integrity must be maintained throughout. If cable is broken for any reason, a screened enclosure correctly terminated must be used with no effective RF apertures. Signal and logic I/O cable screens must only be terminated at one end, preferably at the instrument.

Rigidly employ a star point earthing policy for individual instruments and systems. Do not link earth connections in a daisy chain. Use wide straps or braids for earth connections, as wire exhibits significant inductance and therefore high impedance to RFI. All instruments which have a protective earth terminal must have a sound true earth connection to that terminal.

When completed the screen bonding and earth continuity should be checked with an ohm-meter.

2.5.2 Summary of EMC Guidelines.

- Keep sensor and signal cables as short as possible.
- Do not bundle with electrically noisy cables. Use the recommended separation distances.
- Always use the recommended cables.
- Ensure that the screen integrity is maintained throughout the whole installation.
- Fit suppression devices to contactor coils and other inductive loads such as solenoid valves.
- Ensure a good earth is available and connect all earths separately in star point.

SECTION 3.0 DESCRIPTION OF CONTROLS

3.1 KEYBOARD FUNCTIONS. All functions of the Model 10-P-03 are accessed through keyboard entry routines. The transmitter uses no switches or potentiometers.

The four keys across the top row and the **CAL** and **ENTER** keys are dual function. One press of the key will display the value of the function shown on the lower portion of the key. A quick double press of the key will display the value of the function shown on the upper portion of the key. Each of these keys have read functions that can be accessed without security code entry. Each key also has a calibration or set function when used with the **SELECT** key. This function requires entry of the security code when the security feature is active. (Refer to Section 6.0 for keyboard security.)

NOTE

When no key is pressed for a period of 60 seconds the transmitter will default to reading pH.

CAUTION

The **HOLD** function and the **CAL** function are not read functions. Refer to section 5.3.

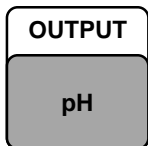

A. Standardize pH. Standardization of the pH sensor is achieved by pressing the **pH** key once, followed immediately by pressing the **SELECT** key. "RdJ" displays to acknowledge the standardize function, followed by the Numeric Display for user input. Entering the known pH of the measured solution will cause the transmitter to restandardize the sensor. The slope value will not be changed. Refer to Section 5.4.

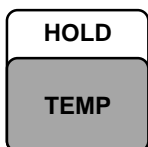

B. Standardize Temperature. Standardization of the temperature is achieved by pressing the **TEMP** key once, followed immediately by pressing the **SELECT** key. "RdJ" displays to acknowledge the standardization function, followed by the Numeric Display for user input. Entering the known temperature of the mea-

sured solution will cause the transmitter to restandardize the temperature reading. Refer to Section 5.2.

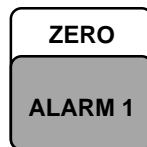

C. Alarm 1 and Alarm 2 Setpoint. The alarm setpoint may be adjusted by pressing the **ALARM 1** or **Alarm 2** key once, followed by pressing the **SELECT** key. "RdJ" displays, followed by the Numeric Display for user input. Refer to Section 4.2.

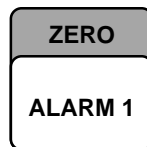

D. Current Output – Zero Setpoint. The zero point (0 or 4 mA) of the pH output range is adjusted by pressing the **ZERO** key twice, followed by pressing the **SELECT** key. "RdJ" displays, followed by the Numeric Display for user input. Refer to Section 4.11.

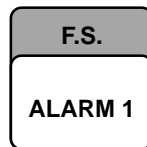

E. Current Output – F.S. Setpoint. The full scale point (20 mA) of the pH output range is adjusted by pressing the **F.S.** key twice, followed by pressing the **SELECT** key. "RdJ" displays, followed by the Numeric Display for user input. The full scale setpoint for the other output. Refer to Section 4.11.

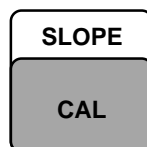

F. Two Buffer Calibration. A two buffer calibration is initiated by pressing the **CAL** key once. Refer to Section 5.3.

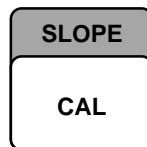

G. pH Glass Slope. The millivolt output per pH unit is adjusted by pressing the **SLOPE** key twice, followed by pressing the **SELECT** key once. "RdJ" displays, followed by the Numeric Display for user input. Refer to Section 5.5.

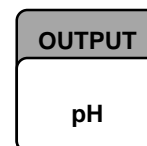

H. Simulate Current Output. The pH output can be simulated by pressing the **OUTPUT** key twice, followed by pressing the **SELECT** key. The Numeric Display appears for user input. Refer to Section 4.12.

3.1.1 Item Selection and Value Adjustment Keys.

The three keys located on the lower right side of the keypad are used for menu navigation, value adjustment and entry, and item selection. These keys perform the following functions:



A. SELECT/Shift (◀) Key. This key is used to select the displayed menu, or for shifting to the next digit in the Numeric Display.

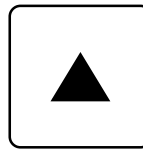

B. Scroll Key (▲) This key is used to scroll through menu when selected, or scroll through digits on the active (flashing) Numeric Display. Holding key down auto scrolls through the main menu and Numeric display.

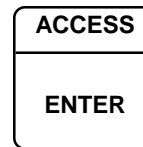

C. ACCESS/ENTER Key. This key is used to **ACCESS** the Set Mode (Section 4.1.2) and to **ENTER** the displayed value into memory (from Numeric Display).

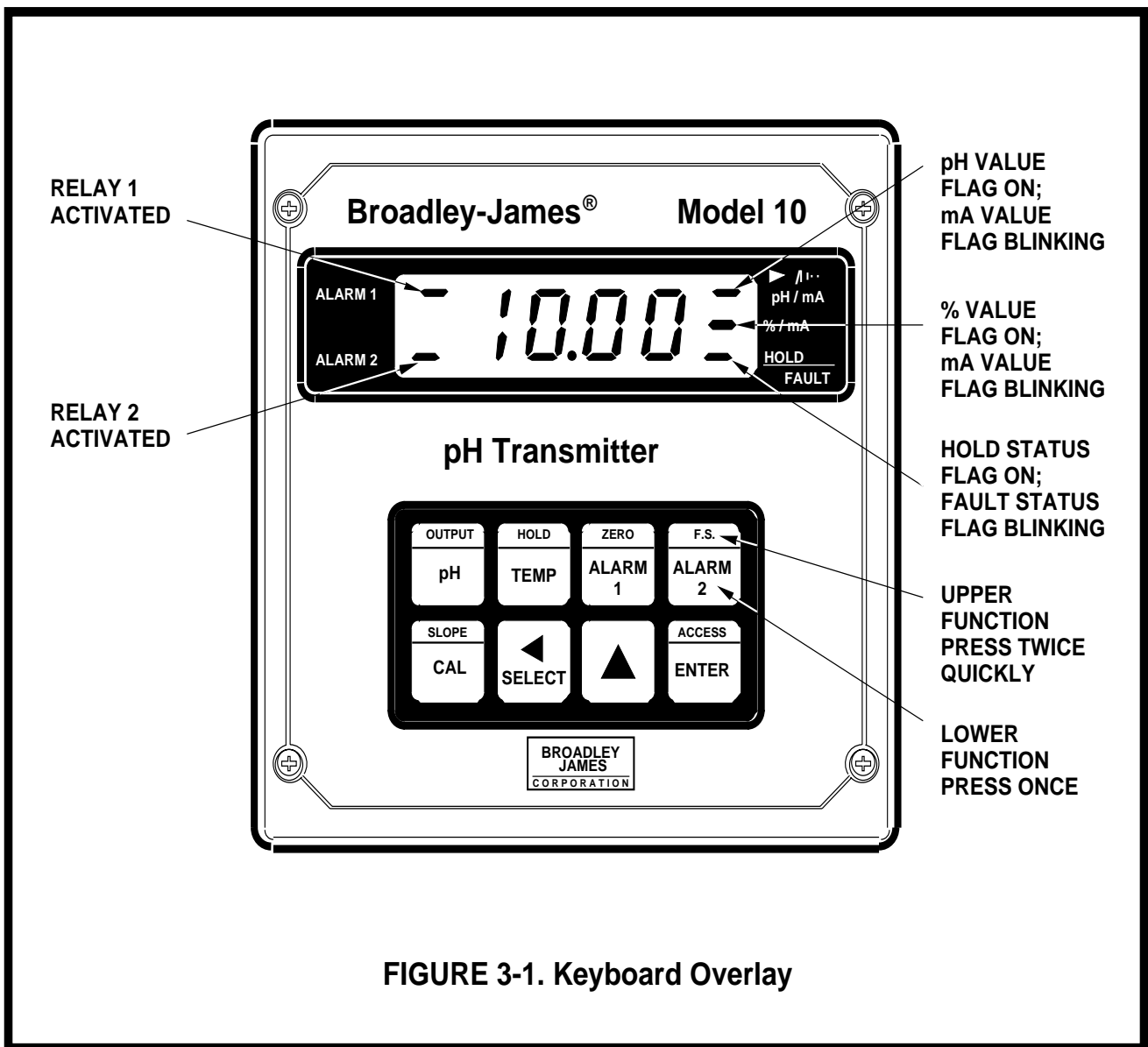

FIGURE 3-1. Keyboard Overlay

Table 3-1. Key Description



MAIN FUNCTION (PRESS ONCE)		SECOND FUNCTION (PRESS TWICE QUICKLY)
<div style="border: 1px solid black; padding: 2px; margin-bottom: 5px;">OUTPUT</div> <div style="border: 1px solid black; padding: 2px;">pH</div>	<p>Displays - pH.</p> <p>Set Function (w/Select) - One point standardization of pH.</p>	<p>Displays - current output (mA or % full scale).</p> <p>Set Function (w/SELECT) - Simulates current output.</p>
<div style="border: 1px solid black; padding: 2px; margin-bottom: 5px;">HOLD</div> <div style="border: 1px solid black; padding: 2px;">TEMP</div>	<p>Displays - process temperature (°C or °F).</p> <p>Set Function (w/SELECT) - One point standardization of temperature.</p>	<p>Initiates or removes transmitter from hold condition.</p>
<div style="border: 1px solid black; padding: 2px; margin-bottom: 5px;">ZERO</div> <div style="border: 1px solid black; padding: 2px;">ALARM 1</div>	<p>Displays - Alarm 1 setpoint.</p> <p>Set Function (w/SELECT) - Sets Alarm 1 setpoint.</p>	<p>Displays - low current setpoint (0 or 4 mA value).</p> <p>Set Function (w/SELECT) - Sets low current point (0 or 4 mA value).</p>
<div style="border: 1px solid black; padding: 2px; margin-bottom: 5px;">F.S.</div> <div style="border: 1px solid black; padding: 2px;">ALARM 2</div>	<p>Displays - Alarm 2 setpoint.</p> <p>Set Function (w/SELECT) - Sets Alarm 1 setpoint.</p>	<p>Displays - full scale output setpoint.</p> <p>Set Function (w/SELECT) - Sets full scale output point.</p>
<div style="border: 1px solid black; padding: 2px; margin-bottom: 5px;">SLOPE</div> <div style="border: 1px solid black; padding: 2px;">CAL</div>	<p>Two Point Calibration.</p>	<p>Displays - electrode slope (efficiency).</p> <p>Set Function (w/SELECT) - manually sets electrode slope (efficiency).</p>
<div style="border: 1px solid black; padding: 5px; text-align: center;">  SELECT </div>	<p>Select sub menu (mnemonic display). Shift to next digit (numeric display).</p>	
<div style="border: 1px solid black; padding: 5px; text-align: center;">  </div>	<p>Scroll through menu (mnemonic display). Scroll digits (numeric display). Holding key down autoscrolls digits or set menu items.</p>	
<div style="border: 1px solid black; padding: 5px; text-align: center;"> ACCESS <hr style="border: 0; border-top: 1px solid black;"/> ENTER </div>	<p>Press twice to access set-up menu. Enter displayed value into memory. Enter displayed menu item (flashing) into memory.</p>	

TABLE 3-2. Information Mnemonics

MNEMONIC	DESCRIPTION	MNEMONIC	DESCRIPTION
Ab 1	Automatic Buffer 1	L0C	Access locked - enter security code
Ab2	Automatic Buffer 2	PcE	Displays pH output in percent
Adj	Adjustment to value reading	PH	pH Display
bAd	Incorrect entry	SEt	Set mode
bF 1	Buffer 1	S, P	Simulates pH output (percent)
bF2	Buffer 2	SC 1	Simulates pH output (mA)
doc	Displays pH output value in mA	SLP	Displays pH electrode slope
Hld	Transmitter in hold mode	SP 1	Displays alarm 1 setpoint
Hi	Displays 20 mA setpoint (pH)	SP2	Displays alarm 2 setpoint
i, tr	Interval timer activated	Std	Standardize pH
L0	Displays 0 or 4 mA setpoint (pH)		

TABLE 3-3. Set Function Mnemonics

AbF	Auto buffer mode	dPn	Dampen output	On	Use alarm as process alarm
AL 1	Alarm 1 setup	dE5	LCD/LED Display test	OFt	Timer off time
AL2	Alarm 2 setup	dur	Timer duration	Old	Old electrode impedance limit
Atc	Automatic temp. comp.	E, n	Display mV input	OUt	Config. output 1 (pH)
°C	Temperature °C	°F	Temperature °F	PcE	Display output in percent
CRL	Calibration impedance setpoint	FLt	Use alarm as fault alarm	rL 1	Relay 1 fault setup
COd	Security Code	Hi	Relay action - high	rL2	Relay 2 fault setup
cnt	Timer count	H-L	Alarm logic	rES	Impedance value
CUr	Config. current output	hr	Hours	rPH	Normal process pH
Cur	Config. fault output 1	HYS	Hysteresis	SEt	Seconds
cUr	Default current setpoint	i, nt	Interval period	SHt	Cracked glass impedance limit
dAY	Days	i, nt	Timer setup	SHD	Show fault history
dFE	Fault Configuration	i, PH	Isopotential pH	t-C	Temperature config.
d-O	Display output	i, 50	Isopotential point	TEt	Temperature coefficient
d-t	Display temperature	L0	Relay action - low	t, L	Timer - time remaining
doc	Display output in mA	non	No action on fault	tOn	Timer status
doF	Relay delay off time	OFF	Alarm not used	UER	User version
don	Relay delay on time	ont	Timer on time	u, n	Minutes
		oFF	Relay open on fault	420	4mA to 20mA output
				020	0mA to 20mA output

SECTION 4.0 CONFIGURATION

4.1 CONFIGURATION. This section details all of the items available in the Set Mode to configure the Transmitter to a specific application.

4.1.1 Configuration Work Sheet. The configuration work sheet on page 25 should be filled out before proceeding with the transmitter's configuration. This sheet gives a brief parameter description, the factory setting, and a space for user setting.

4.1.2 Set Mode. Display mnemonic "SET". Most of the transmitter's configuration is done while in the Set Mode. Please refer to Figure 4-1 for the layout of all menu items. All menu variables are written to the transmitter's EEPROM (memory) when selected and remain there until changed. As these variables remain in memory even after the transmitter's power is removed, the Model 10-P-03 configuration may be performed prior to installing it.

1. Power up the transmitter. Only power input wiring is required for transmitter configuration. (Refer to Section 2.4.1.) The transmitter's display will begin showing values and/or fault mnemonics. All fault mnemonics will be suppressed while the transmitter is in Set Mode (the fault flag will continue to blink).

2. Enter Set Mode. Pressing the ACCESS key twice in rapid succession will place the transmitter in Set Mode. The display will show "SET" to confirm that it is in Set Mode. It will then display the first item in the Set Menu "Ein". The transmitter is now ready for user configuration.

NOTE

If "LOC" displays, the Keyboard Security Code must be entered to access the Set Mode. (Refer to Section 6.0.)

3. (Refer to the configuration work sheet on page 25.) Transmitter variables can be entered in any order. On initial configuration, however, it is recommended that the variables be entered in the order shown on the work sheet. This will reduce the chance of accidentally omitting a needed variable.

FIGURE 4-1. Menu Items

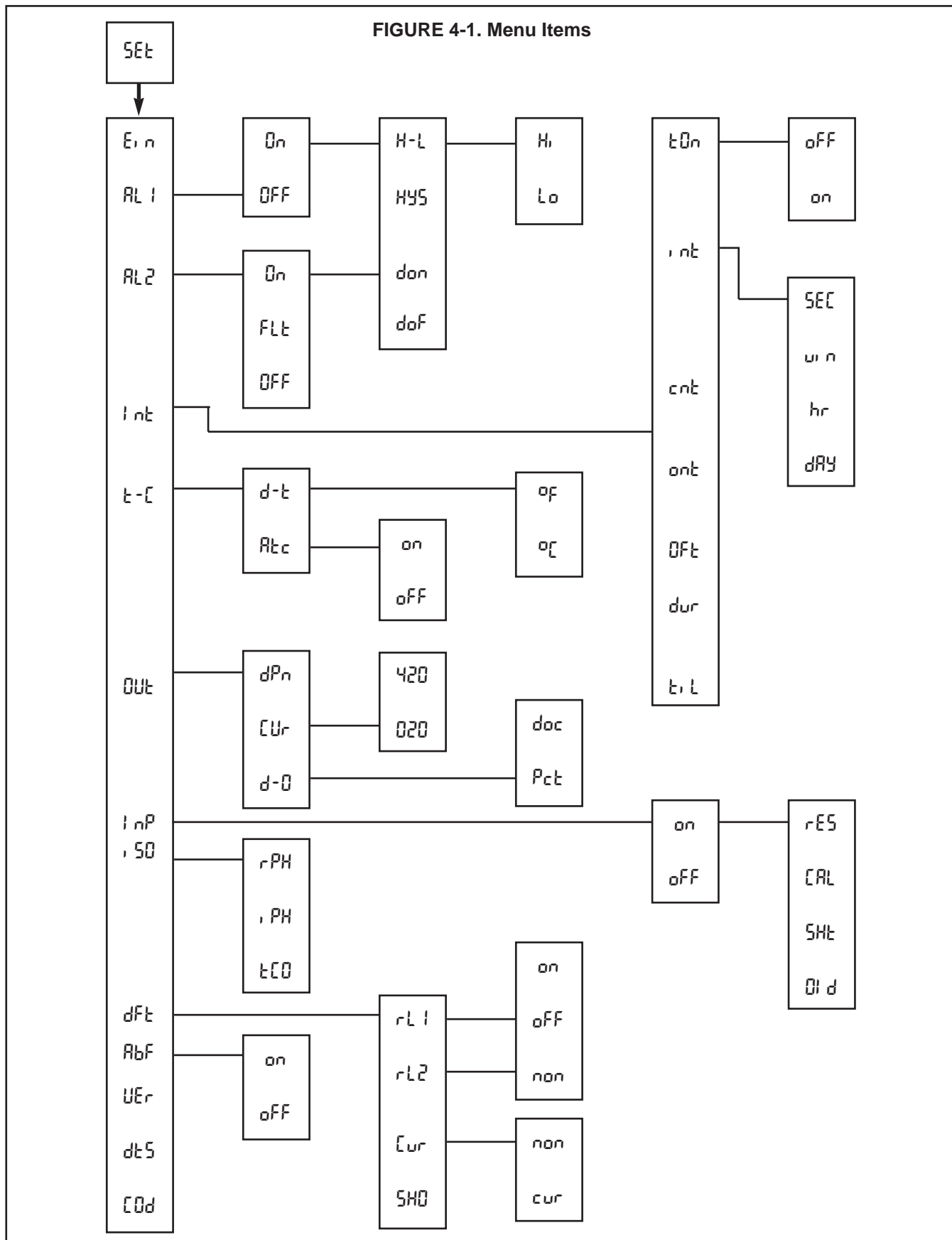

TABLE 4-1. Configuration Work Sheet

Use this work sheet to assist in the configuration of the transmitter.

Date: _____

	RANGE	FACTORY SET	USER SET
A. Alarm 1 Setup (AL 1)			
1. Alarm Configuration (ON/OFF)		ON	_____
2. High or Low (H-L) (Hi /Lo)		Lo	_____
3. Hysteresis (HYS)	0-2.0 pH	0 pH	_____
4. Delay Time On (dOn)	0-255 sec.	000 Seconds	_____
5. Delay Time Off (dOff)	0-255 sec.	000 Seconds	_____
B. Alarm 2 Setup (AL 2)			
1. Alarm Configuration (ON/FLt/OFF)		ON	_____
2. High or Low (H-L) (Hi /Lo)		Hi	_____
3. Hysteresis (HYS)	0-2.0 pH	0 pH	_____
4. Delay Time On (dOn)	0-255 sec	000 Seconds	_____
5. Delay Time Off (dOff)	0-255 sec	000 Seconds	_____
C. Interval Timer (Int)			
1. Active Status (tOn) (oFF/on)		oFF	_____
2. Interval Time (int)	Minimum 10 Minutes	10 Seconds	_____
3. Count (cnt)	1 to 60	5	_____
4. On Time (onT)	0 to 299 sec	1 Second	_____
5. Off Time (offT)	0 to 299 sec	1 Second	_____
6. Duration (dur)	0 to 299 sec	2 Seconds	_____
D. Temperature Setup (t-C)			
1. Display Temperature (d-t) (°C/°F)		°C	_____
2. Automatic Temperature Compensation (Atc) (on/oFF)		on	_____
a. Manual Temp. Value	-10°C to 125°C		_____
E. Current Output Setup (CUt)			
1. mA Output (Cur) (020/420)		420	_____
2. Display Current Output (d-C) (Pct/dac)		dac	_____
3. Dampen Current Output (dPn)	0-255 sec.	0.0 Seconds	_____
F. Electrode Diagnostics Setup (IDP)			
	(on/oFF)	oFF	_____
1. Temp compensated impedance (rES)			_____
2. Impedance increase before calibration (IRL)	20-200%	20%	_____
3. Cracked glass impedance low limit (5Ht)	5-600 megohms	20 megohms	_____
4. Aged electrode impedance high limit (Hd)	200-1999 megohms	1000 megohms	_____
G. Default Setup (dFt)			
1. Relay 1 Default (rL 1) (non/oFF/on)		non	_____
2. Relay 2 Default (rL 2) (non/oFF/on)		non	_____
3. Current Output Default (Cur) (non/cur)		non	_____
H. Automatic Buffer Mode (AbF)			
1. Configuration (on/oFF)		on	_____
I. Keyboard Security Setup (KSD)			
1. Keyboard Security Required	001-999	-	_____
2. Keyboard Security Not Required	000	000	_____
Alarm Setpoints			
1. Alarm 1 (SP 1)	0-14 pH	0.00 pH	_____
2. Alarm 2 (SP 2)	0-14 pH	14.00 pH	_____
Current Output			
1. Zero (0 or 4 R) (L0)	0-14 pH	0.00 pH	_____
2. F.S. (20 R) (Hi)	0-14 pH	14.00 pH	_____

4.2 Alarm 1 and 2. Display Mnemonic "RL 1" or "RL 2". Used to set alarm relay logic. The alarms may be configured to perform on-off process control. See note below.

A. On. Display Mnemonic "On". Select this item if Alarm 1 or 2 is to be used as a process alarm. See Steps D thru G for further alarm configuration.

B. Off. Display Mnemonic "OFF". Select this item if Alarm 1 or 2 will not be used as a process alarm or to temporarily disable either alarm. Alarm 1 or 2 setpoint will display "OFF" if this item is selected. Omit Steps C thru G.

C. Fault (Alarm 2 Only). Display Mnemonic "FLT". Select to make Alarm 2 energized when the transmitter detects a fault condition. See Table 8-1 for a listing of the fault mnemonics and their descriptions. Alarm 2 setpoint will display "FLT" if this item is selected. Omit Steps D thru G.

D. Alarm Logic. Display Mnemonic "H-L". Select this item for high or low alarm logic. High logic activates the alarm when the reading is greater than the set point value. Low logic activates the alarm when the reading is less than the setpoint value.

E. Relay Hysteresis. Display Mnemonic "HYS". Sets the relay hysteresis (dead band) for deactivation after reading has passed the alarm setpoint. May be set from 0 to 2.0 pH. Use hysteresis when a specific pH should be reached before alarm deactivation.

F. Delay Time On. Display Mnemonic "don". Sets time delay for relay activation after alarm setpoint is reached. May be set from 0 to 255 seconds.

G. Delay Time Off. Display Mnemonic "dof". Sets time delay for relay deactivation after alarm setpoint is reached. May be set from 0 to 255 seconds. Alarm state restarts time from zero. Use when a fixed time should pass before relay deactivation occurs.

NOTE

Alarm logic may be changed from normally open (N.O.) to normally closed (N.C.) by cutting bowties on the power supply PCB and adding a jumper between W4 and W5, and or W6 and W7, and or W8 and W9.

4.2.1 Alarm Setup (RL 1/RL 2).

1. Enter Set Mode by pressing **ACCESS** key twice.
2. **SCROLL** (▲) until "RL 1" or "RL 2" appears on the display.
3. **SELECT** to move to the next menu level. "On", "OFF" or (RL 2 only) "FLT" will display.
4. **SCROLL** (▲) to display desired item then **SELECT**.
5. If "OFF" is selected, display will show "OFF" to acknowledge. Press **ENTER** key to return to "RL 1" or "RL 2", concluding routine. Skip to Step 11.

If "On" is selected, display will show "On" to acknowledge, then display "H-L". Proceed to Step 6.

If "FLT" is selected, display will show "FLT" to acknowledge. Press **ENTER** key to return to "RL 2".
6. **SELECT** "H-L". "H" or "Lo" will display (flashing).
7. **SCROLL** (▲) to the desired item and **ENTER** it into memory. Display will return to "H-L". If changes to relay activation logic are desired, proceed to Step 8, otherwise Step 12.
8. **SCROLL** (▲) to display "HYS", "don" or "dof", then **SELECT** desired item. The Numeric Display will flash to indicate that a value is required.
9. Use **SCROLL** (▲) and **SHIFT** (◀) to display the desired value.
10. **ENTER** value into memory. Transmitter will acknowledge and return to display of last item selected. Repeat Step 8 if further changes are desired, otherwise Step 12.
11. Repeat Step 3 for the other Alarm's settings as required.
12. To return to the first level of the Set Mode, press the **ACCESS** key.

FIGURE 4-2. Alarms 1 and 2 Configuration

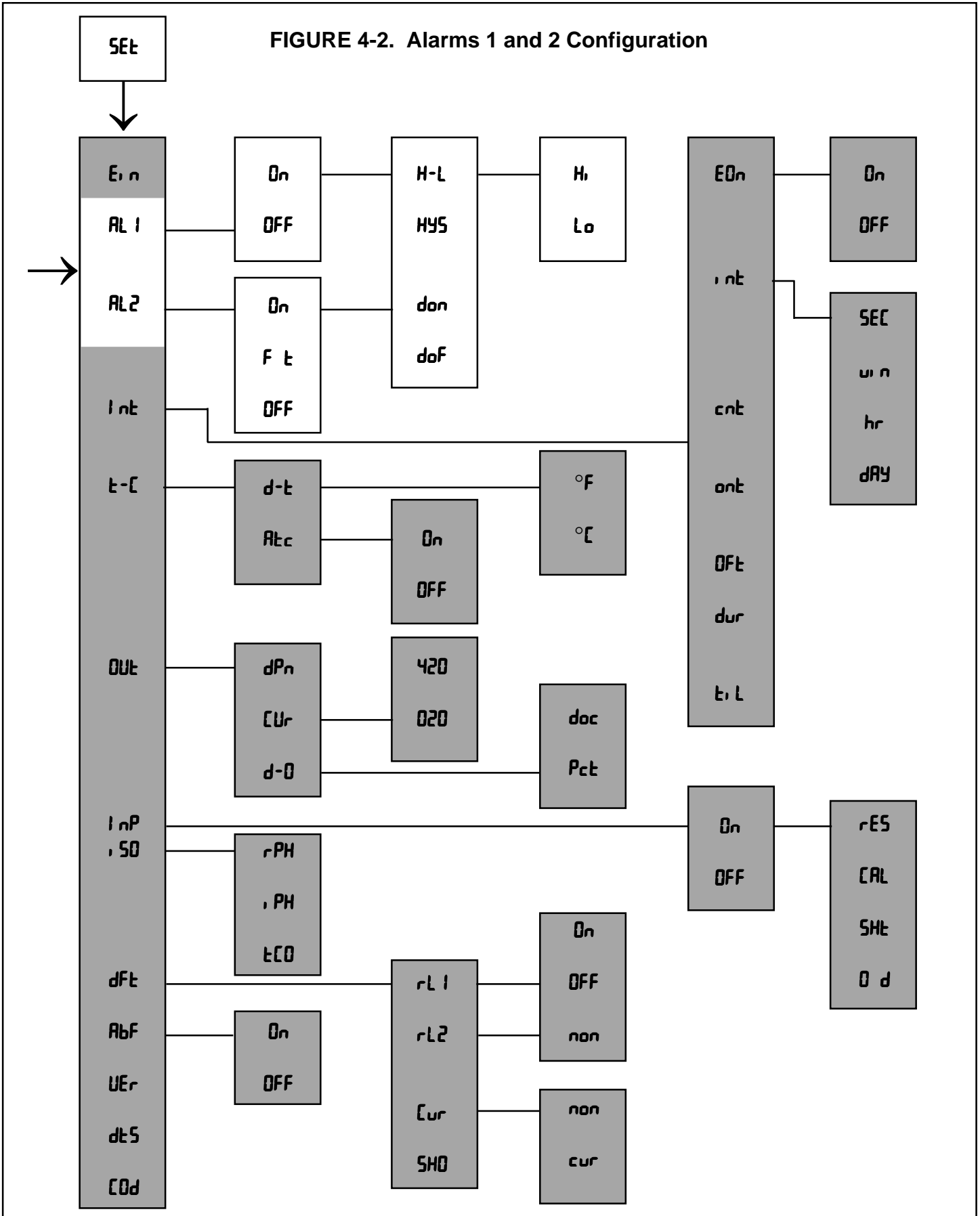

4.3 Interval Timer. Display Mnemonic “i nt”. This item is used to set the interval timer’s relay logic. The timer can be used for sensor maintenance, such as wash cycle or ultrasonic cleaner activation. Refer to Figure 4-3A.

A. Interval Timer Enable/Disable. Display Mnemonic “t0n”. Select this item to begin interval cycle “on” or disable interval cycle “off”.

B. Interval Period. Display Mnemonic “i nt”. Select this item to set the time period between control cycles. “SEc” for seconds, “mi n” for minutes, “hr” for hours, and “dAY” for days. May be set from a minimum of 10 minutes.

C. Relay Activations Per Cycle. Display Mnemonic “cnt”. Select this item to enter the number of times the relay will activate per cycle. May be set from 1 to 60.

D. Relay Activation Duration. Display Mnemonic “ont”. Select this item to enter the relay activation time for each “cnt”. May be set from 0 to 299 seconds.

E. Relay Deactivation Duration. Display Mnemonic “offt”. Select this item to enter the relay deactivation time between each “cnt” during the control cycle. Valid when “cnt” is 2 or greater. May be set from 0 to 299 seconds.

F. Wait Duration. Display Mnemonic “dur”. Select this option to enter the electrode recovery time after the last “cnt” in a cycle. May be set from 0 to 299 seconds. The duration can be used for electrode recovery after a wash cycle.

G. Interval Time Remaining. Display Mnemonic “t, l”. Select this item to display the time remaining until the next control cycle. If selected during the control cycle, the display will show “—”.

NOTE

The Model 10-P-03 is placed on hold during the control cycle (from first relay activation through the wait duration). The transmitter will simulate a fault condition and briefly show “itr” every eight seconds. The display will continue to show the measured value.

4.3.1 Interval Timer Set Up (Int).

1. Enter Set Mode by pressing **ACCESS** key twice.
2. **SCROLL (▲)** until “i nt” appears on the display.
3. **SELECT** to move to the next menu level. “t0n” will display.
4. **SCROLL (▲)** to display “on” or “off” and **ENTER** it into memory. If interval configuration is required, proceed to Step 5, otherwise Step 10.
5. **SCROLL (▲)** to display desired menu item. If “i nt” is selected, proceed to Step 6, otherwise Step 10.
6. **SCROLL (▲)** to display desired interval period and **SELECT**. The Numeric Display will flash.
7. **SCROLL (▲)** and **SHIFT (◀)** to display the desired value and **ENTER** it into memory. Display will return to interval period menu.
8. Repeat Steps 6 and 7 as needed.
9. Press the **ENTER** key to return to the main timer menu.
10. **SELECT** the desired item. The Numeric Display will flash.
11. **SCROLL (▲)** and **SHIFT (◀)** to display the desired value and **ENTER** it into memory.
12. Repeat Steps 5, 10, and 11 as required.
13. Press the **ENTER** key to return to the Set Menu.

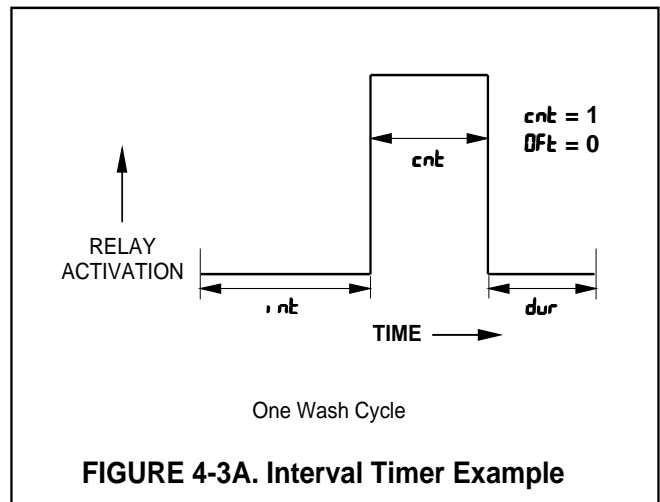
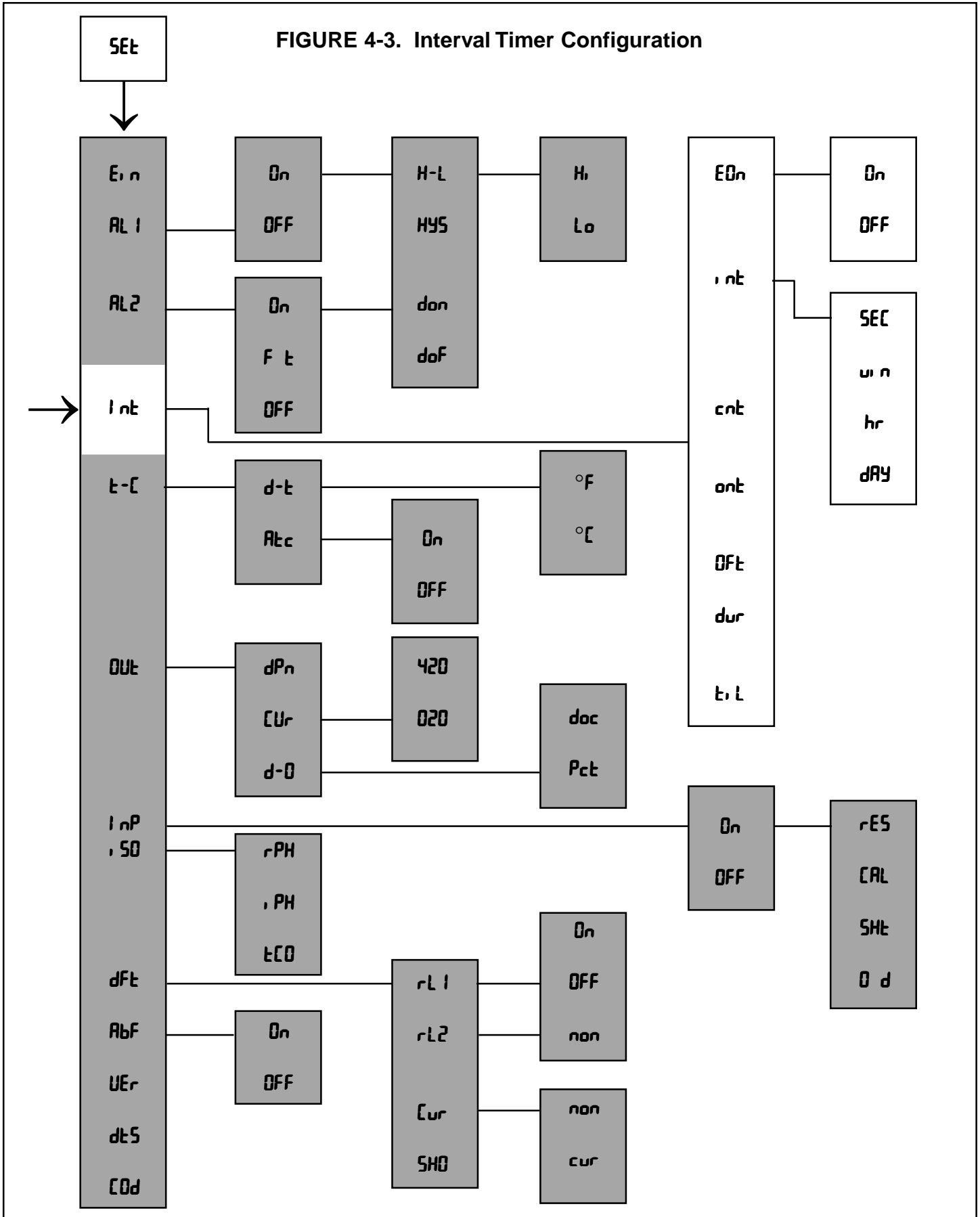

FIGURE 4-3A. Interval Timer Example

FIGURE 4-3. Interval Timer Configuration



4.4 Temperature. Display Mnemonic "t-[-". Select this item for temperature reading and compensation choices.

A. Temperature Display. Display Mnemonic "d-t". Select this item to toggle between °F and °C temperature display. The Model 10-P-03 will show all temperatures in units selected until the selection is changed.

B. Automatic Temperature Compensation. Display Mnemonic "Rt[-". The Model 10-P-03 will use the temperature input from the RTD sensor for temperature compensation when "on" is selected.

C. Manual Temperature Compensation. Display Mnemonic "Rt[-". When "off" is selected, the transmitter will use the value entered by the user for temperature compensation. This manual temperature option is useful if the temperature sensor is faulty or not on line. Temperature specific faults ("tch" and "tcl") will be disabled. (Refer to Table 8-1.)

The display for the temperature value entered by the user will only be shown during the procedure of entering this value. The Model 10-P-03 will use this value for temperature compensation until this value is changed by the user and/or the RTD sensor is installed for automatic temperature compensation and the transmitter is reconfigured per step **B** above.

While in the Manual Temperature Compensation mode, when the **TEMP** key is pressed, the display will indicate a random temperature which does not relate to the actual process temperature or the temperature compensation value selected by the user.

NOTE

A jumper must be installed between TB2-6 and -7 when operating with the Manual Temperature Compensation feature. This jumper must also be in place when using a 2-wire RTD sensor which is connected to TB2-5 and TB2-7

4.4.1 Temperature Setup ("t-[-").

1. Enter Set Mode by pressing **ACCESS** key twice.
2. **SCROLL** (▲) until "t-[-" appears on the display.
3. **SELECT** to move to the next menu level. "d-t" will display.
4. **SCROLL** (▲) to display desired item, then **SELECT**.
5. If "d-t" is selected, display will show "o[-" or "oF".
If "Rt[-" is selected, display will show "on" or "off".
6. **SCROLL** (▲) then **ENTER** desired item into memory.
7. If "o[-", "oF" or "on" are entered, display will return to the previous level (proceed to Step 9).

If "off" is selected, the Numeric Display will flash indicating that a process temperature value is required (proceed to Step 8).
8. Use **SCROLL** (▲) and **SELECT** (◀) to display the desired value. **ENTER** value into memory.
9. Repeat Steps 4-8 as required for other item.
10. Press the **ENTER** key to return to Set Menu.

FIGURE 4-4. Temperature Configuration

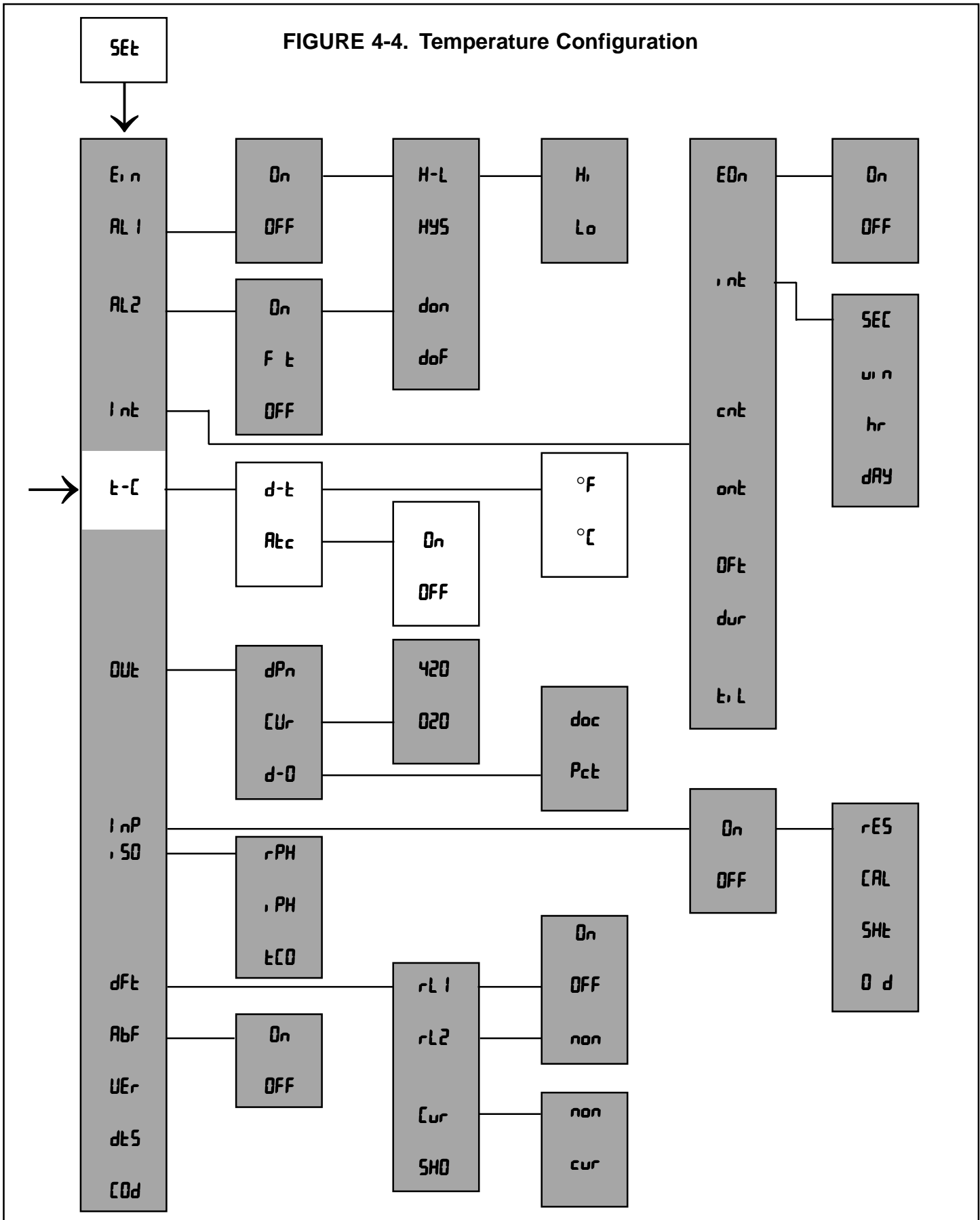

4.5 Current Output. Display Mnemonic "OUT". This item is used to configure the current output signal.

A. Output Dampening. Display Mnemonic "dPn". Dampens the response of the signal output. This option is useful to minimize the effect of a noisy reading. The number entered is the sample time (in seconds) for an averaged output. Zero to 255 seconds may be entered.

B. mA Output Range. Display Mnemonic "CUR". Selection of this item will allow choice of 0 to 20 mA or 4 to 20 mA output range.

C. Display Output. Display Mnemonic "d-D". This item is used to select logic of output display. Selecting this item will allow the Model 10-P-03 to display current output as mA "dDC" or as a percent of full scale output range "Pct".

4.5.1 Output Setup (OUT).

1. Enter Set Mode by pressing the **ACCESS** key twice .
2. **SCROLL (▲)** until "OUT" appears on the display.
3. **SELECT** to move to the next menu level. "dPn" will display.
4. **SCROLL (▲)** then **SELECT** desired item.
5. If "dPn" is selected, the Numeric Display will flash indicating that a value is required. Proceed to Step 6. If "CUR" or "d-D" is selected, proceed to Step 7.
6. **SCROLL (▲)** then **SELECT (◀)** to display the desired value. **ENTER** into memory.
7. **SCROLL (▲)** then **ENTER** desired item.
8. Repeat Steps 4-7 as required.
9. Press the **ENTER** key to return to the Set Menu.

FIGURE 4-5. Current Output Configuration

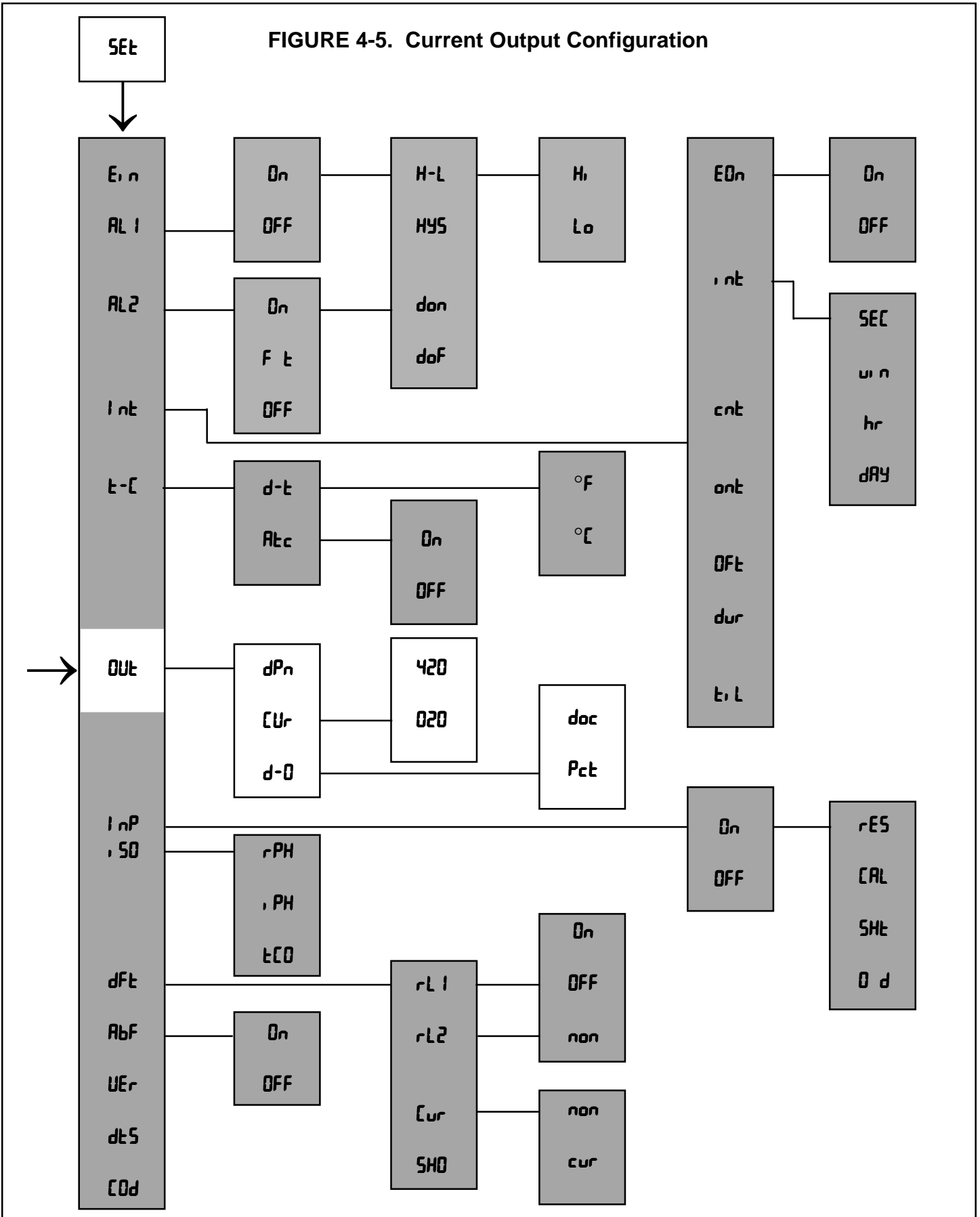

4.6 pH Electrode Diagnostics. Display Mnemonic “i nP”. Under this item are functions associated with glass electrode diagnostics. These diagnostics are possible through a continuous, temperature compensated measurement of the sensor impedance (resistance), “rE5”, made from the preamp. **A software selectable “on” setting will activate these diagnostics. If “off” is the setting (factory setting) these diagnostics will all be disabled.**

A new electrode has an impedance of approximately 200 megohms, and as it ages the impedance increases because lithium ions (which carry current) in the glass slowly get depleted by the process. If an electrode cracks, the impedance drops sharply, usually to below 70% of the normal value.

The following are typical impedance values for **new** Broadley-James electrodes (Electrodes stored over a period of time will have higher impedances). Upon installation you can read impedance in megohms under “rE5”.

<u>Sensor/Glass Type</u>	<u>Megohms @ 25°C (77°F) when new</u>
• GP General Purpose, low impedance	50-150
• HT-3 Industrial Grade	70-200
• HT-4 High pH (>12.0)	500-700

For more information on these diagnostics and troubleshooting, refer to section 8.0.

NOTE

Impedance diagnostic faults are not activated until the setpoint is continuously exceeded for 30 seconds.

A. Calibration Warning. Display Mnemonic “E R L”. Under this mnemonic you can select the percent increase in impedance before a calibration warning fault appears. For example, if the impedance is 400 megohms and the setpoint is 20% (factory setting), a “E R L” warning will appear on the transmitter and it will go into a fault mode when the electrode ages to 480 megohms. This diagnostic will reset after a buffer calibration. Configurable range: 20-200%. A setting of zero disables this fault.

NOTE

The recommended process temperature range for the “E R L” diagnostic is 15-90°C (15-194°F.) (For low impedance glass it is 15-80°C (59-

176°F). If ruggedized glass is used and the preamp is not close to the pH sensor, the minimum recommended temperature is 35°C (95°F).

If you want to use this feature as a warning yet not upset your process, use Alarm 2 as a fault alarm (Refer to Section 4.2) and set the default current output to “non” (Refer to Section 4.8) to hold the output at the last process value.

You may also get this fault if:

1. The glass electrode or liquid junction becomes excessively coated.
2. The electrode is not immersed in the process fluid. If the electrode continues to remain out of solution eventually the fault mnemonic “E d” will also appear on the display. See part C.

B. Cracked Glass Diagnostic. Display Mnemonic “5H L”. One way to tell that you have a broken or cracked glass electrode is that the transmitter will read a constant value (usually between 5.0-7.0 pH) in any process or buffer. The other way is to note the impedance value. When a crack occurs the mnemonic “5H L” will appear on the transmitter to indicate that the circuit is shorted, and the transmitter will go into a fault mode. Directions for “5H L” value determination:

“5H L” ~ 70% of normal “rE5”

Configurable range: 5-600 megohms. A setting of zero disables this fault. Factory setting: 20 megohms.

NOTE

For low impedance glass, a broken electrode may not be detectable above 70-75°C (158-167°F).

C. Worn Out Electrode. Display Mnemonic “E d”. This mnemonic is used for programming the high impedance limit of the electrode. For example, if the setpoint is 1000 megohms (factory setting), and the impedance rises above this value, the mnemonic “E d” will appear on the transmitter and it will go into a fault mode. The electrode is either worn out, severely coated, or not immersed in the process fluid. Configurable range: 200-1999 megohms. A setting of zero disables this fault.

Recommended setpoints:

1. 1000 megohms for all GP glass
2. 1500 megohms for HT-3 and HT-4 glass

FIGURE 4-6. pH Electrode Diagnostics Configuration

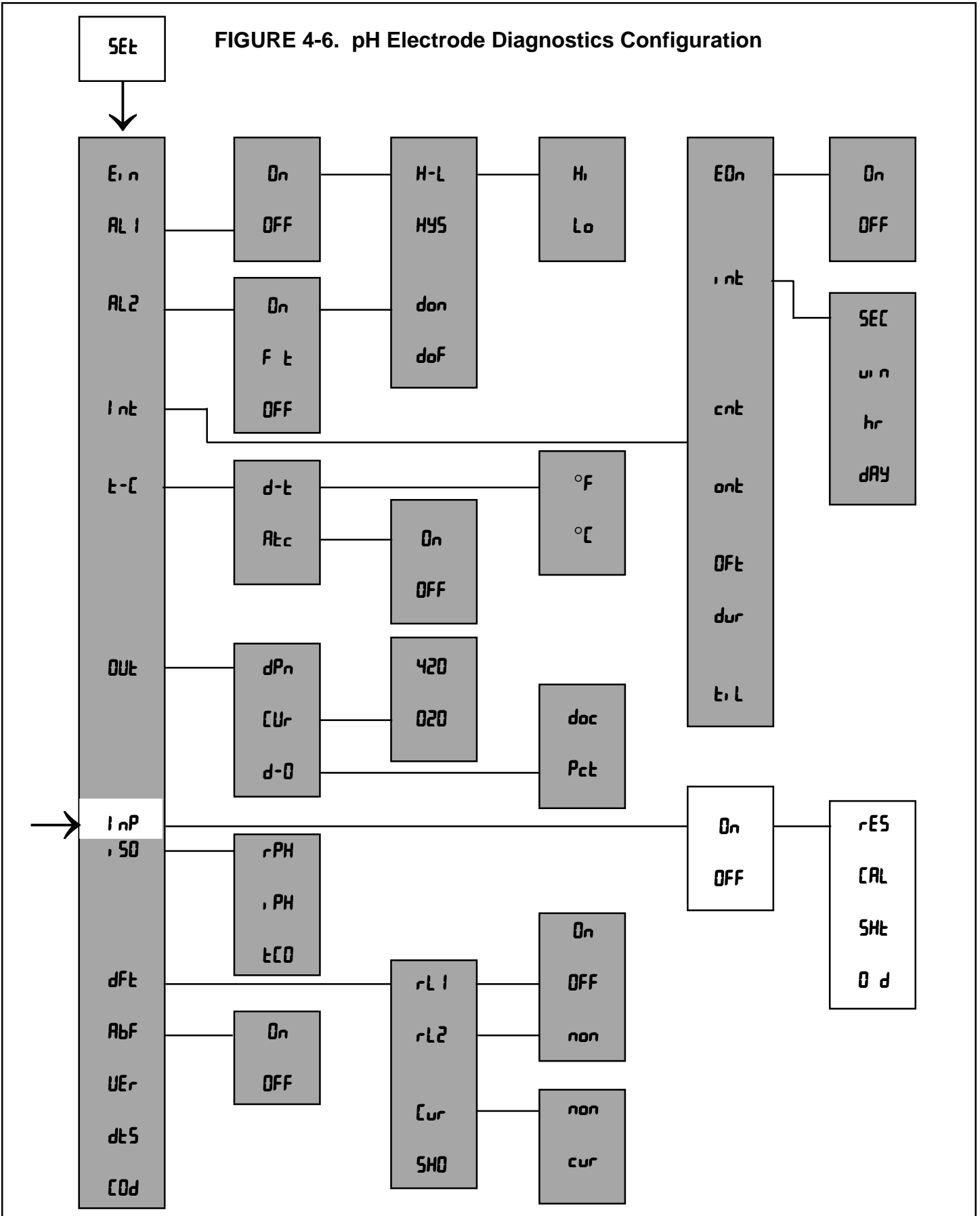

4.6.1 pH Electrode Diagnostics Setup

1. Enter the Set Menu by pressing the **ACCESS** key twice.
2. **SCROLL (▲)** until “i nP” appears on the display and **SELECT**.
3. “on” or “oFF” will display. If necessary, **SCROLL (▲)** to the desired mnemonic then enter. “on” activates the diagnostics features.
4. If “oFF” is entered you can press the **ENTER** key to return to the main set menu or press the pH key to read pH.
If “on” is entered, the display will show “rE5”. Proceed to Step 5.
5. **SCROLL (▲)** to display “rE5”, “rRL”, “5HL”, or “Di d”, then **SELECT** the desired item. “rE5” is a read only function. If “rRL”, “5HL”, or “Di d” is selected, the right most digit of the Numeric Display will flash to indicate that the value can be changed.
6. Use the **SCROLL (▲)** and **SELECT (◀)** keys to change the value, if desired.
7. **ENTER** the value into memory.
8. Press **ENTER** to return to the main Set Menu.

4.7 SOLUTION TEMPERATURE COMPENSATION AND ISOPOTENTIAL POINT.

Display Mnemonic “i 50”. Used for applications where the process’ isopotential point (“i PH”) and temperature coefficient (“tL0”) are not standard. For normal pH measurements these values should be: “rPH” = 7.00 (normal process pH), “i PH” = 7.00 pH, “tL0” = 0.00 pH/°C. These values should only be changed for special applications.

Solution temperature compensation is designed to correct for changes in the actual pH of a solution caused by changes in dissociation with temperature. During standardization (section 5.4), if the sample pH is greater than about 6.5 and the lab test is run at a substantially different temperature than the process, determine a value for “tL0” in pH/°C and enter that value. The “tL0” should be determined over as narrow a temperature operating range as possible.

The isopotential point is the pH value at which temperature changes do not affect the pH reading. The transmitter method requires the user to enter the normal process pH (“rPH”) and the temperature coefficient (“tL0”), then the isopotential point (“i PH”) will be calculated. Conversely, entering the normal process pH and the isopotential point causes the temperature coefficient to be calculated.

4.7.1 pH Measurement in High Purity Water with Ammonia Present. The special characteristics of this measurement require changing isopotential pH value and temperature coefficient used by the Model 10-P-03. The reference pH (rPH) is the user’s normal process pH. The isopotential pH value (i PH) of high purity water with ammonia is 6.84 pH. The temperature coefficient “tL0” is – 0.033 pH/°C.

4.7.2 Isopotential Point Set Up (i 50).

1. Enter Set Mode by pressing the **ACCESS** key twice.
2. **SCROLL (▲)** to display “i 50” and **SELECT**.
3. **SCROLL (▲)** to the desired menu item and **SELECT**. The Numeric Display will flash.
4. **SCROLL (▲)** and **SELECT (◀)** to display the desired value and **ENTER** it into memory.
5. Repeat Steps 3 and 4 as required.
6. Press the **ENTER** key to return to the Set Menu.

FIGURE 4-7.
Solution Temperature Compensation and
Isopotential Point Configuration

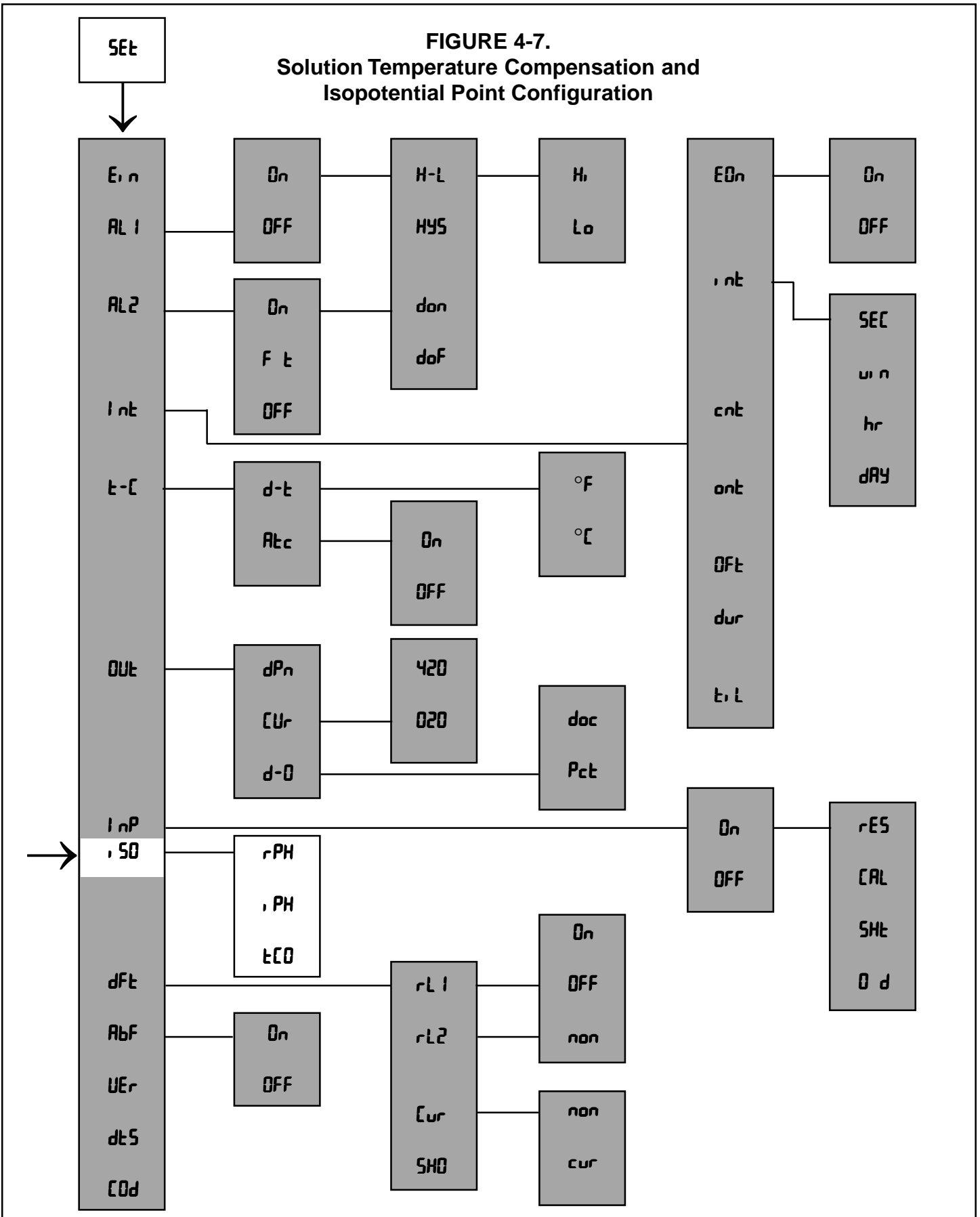

4.8 DEFAULTS. Display Mnemonic “dFt”. This item is used to set the configuration of relays and output default conditions during fault or hold status. See Table 8-1 for a listing of the possible fault conditions which can be diagnosed by the transmitter.

A. Relay 1 and 2. Display Mnemonic “rL 1” and “rL 2”. During a fault or hold condition the relays can be set to activate “on”, deactivate “oFF”, or remain in the state determined by the last process value “non”. See Table 4-2.

B. Current Output. Display Mnemonic “cur”. The current output is held at the last process value “non” or goes to a specified value in mA “cur” during a fault or hold condition.

C. Fault History. Display Mnemonic “SHD”. **SELECT** (◀) this item will sequence the display through all faults detected in most recent fault mode. Press the **SCROLL** (▲) key once for previous fault mode list. Pressing **ACCESS** will clear “SHD” history.

4.8.1 Default Setup (dFt).

1. Enter Set Mode by pressing the **ACCESS** key twice.
2. **SCROLL** (▲) until “dFt” appears on the display.
3. **SELECT** to move to the next menu level. “rL 1” will display.
4. **SCROLL** (▲) then **SELECT** desired item.
5. Display will show next item selection. **SCROLL** (▲) and **ENTER** desired item.
6. Repeat Steps 4 and 5 as required for other default settings “rL 2” and “cur”. If “cur” is selected for “cur” press **ENTER**, then use the **SCROLL** (▲) and **SELECT** (◀) keys to enter the desired current value for a fault or hold condition.
7. Press the **ENTER** key to return to Set Menu.

TABLE 4-2. Relay States for Various Transmitter Conditions and Alarm/Default Configurations

Set menu default (dFt) setting rL 1/rL 2	TRANSMITTER CONDITION								
	NORMAL			HOLD			FAULT		
	Set menu rL 1/rL 2 setting			Set menu rL 1/rL 2 setting			Set menu rL 1/rL 2 setting		
	on	oFF	F Lt (Alarm 2 only)	on	oFF	F Lt (Alarm 2 only)	on	oFF	F Lt (Alarm 2 only)
on	Proc. det.	–	–	+	–	–	+	–	+
oFF	Proc. det.	–	–	–	–	–	–	–	+
non	Proc. det.	–	–	Proc. det.	–	–	Proc. det.	–	+

Proc. det.: Alarm state is determined by the process value

- + : Relay will activate
- : Relay will not activate

Example: If you want the transmitter to activate relay 1 in hold mode during buffer calibration, set “rL 1” to “on” in Section 4.2, and set “rL 1” to “on”.

FIGURE 4-8. Default States Configuration

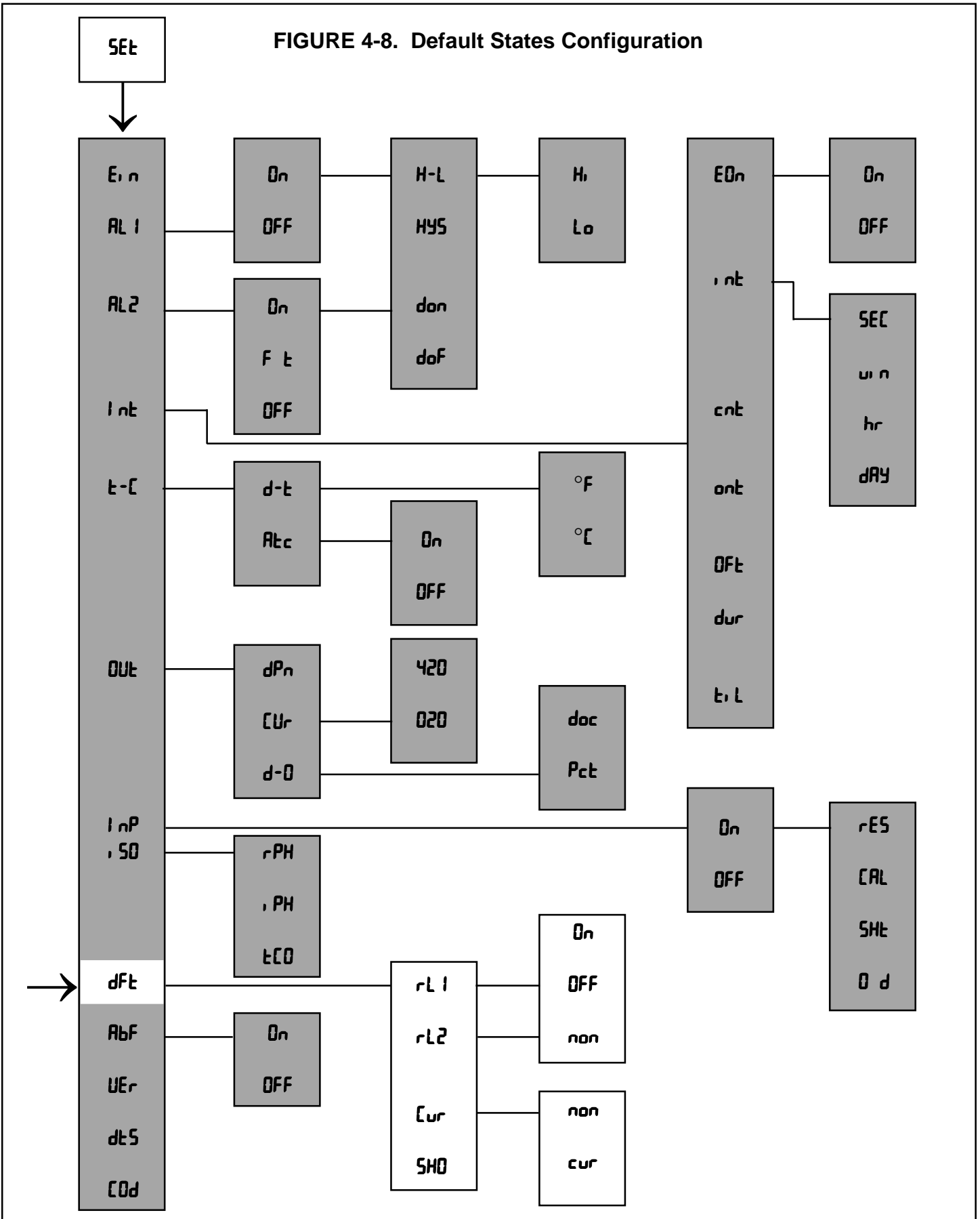

4.9 Automatic Buffer Mode. Display Mnemonic "RbF". Software selectable "on" or "off". **Factory setting** is "on". With the "off" setting, calibration is performed according to section 5.3.2, without automatic recognition and temperature compensation of the buffers.

The automatic buffer calibration feature ("on" setting) provides automatic recognition of up to three of the buffers listed below (selectable in section 5.3.1). In addition, each buffer selection incorporates a temperature curve from 0-50°C so that the user does not need to determine the correct buffer pH which corresponds to the buffer temperature (for best accuracy in extreme temperature environments).

The stored buffer-temperature curves were generated from reference data according to NBS (National Bureau of Standards - U.S.), DIN 19266 (Germany), BSM (British Standards Method), and JIS 8802 (Japan) standards. The buffers are supplied by a wide variety of vendors.

NOTE

If any buffers other than those listed here will be used (such as some Fisher or Ingold buffers), the "AbF" setting should be "off" and calibration instructions followed in section 5.3.2.

4.9.1 Automatic Calibration Setup.

1. Enter the Set mode by pressing the **ACCESS** key twice.
2. **SCROLL** (▲) until "RbF" appears on the display.
3. Press **SELECT**. "on" or "off" will be displayed.
4. Press **SCROLL** (▲) if the desired item is not displayed. Then press enter. You will be returned to the set menu.

Buffer Value at 25°C	Standards Referenced	Buffer Composition	Factory Selection
1.68	NBS, DIN 19266, JIS 8802	0.05M K tetroxalate	
3.56	NBS, BSM	KH tartrate (sat'd @ 25°C)	
3.78	NBS	0.05M KH ₂ citrate	
4.01	NBS, DIN 19266, BSM, JIS 8802	0.05M KH Phthalate	*
4.64	BSM	0.1M HOAc	
		0.1M NaOAc	
6.86	NBS, DIN 19266, BSM, JIS 8802	0.025M KH ₂ PO ₄	*
		0.025M Na ₂ HPO ₄	
7.41	NBS, JIS, 8802	0.0087M KH ₂ PO ₄	
		0.0302M KH ₂ HPO ₄	
9.18	NBS, DIN 19266, BSM, JIS 8802	0.01M Na ₂ B ₄ O ₇	*
10.01	NBS, BSM, JIS, 8802	0.025m NaHCO ₃	
		0.025M Na ₂ CO ₃	
12.45	NBS, DIN 19266	Ca (OH) ₂ (sat'd @ 25°C)	

FIGURE 4-9. Automatic Buffer Mode Configuration

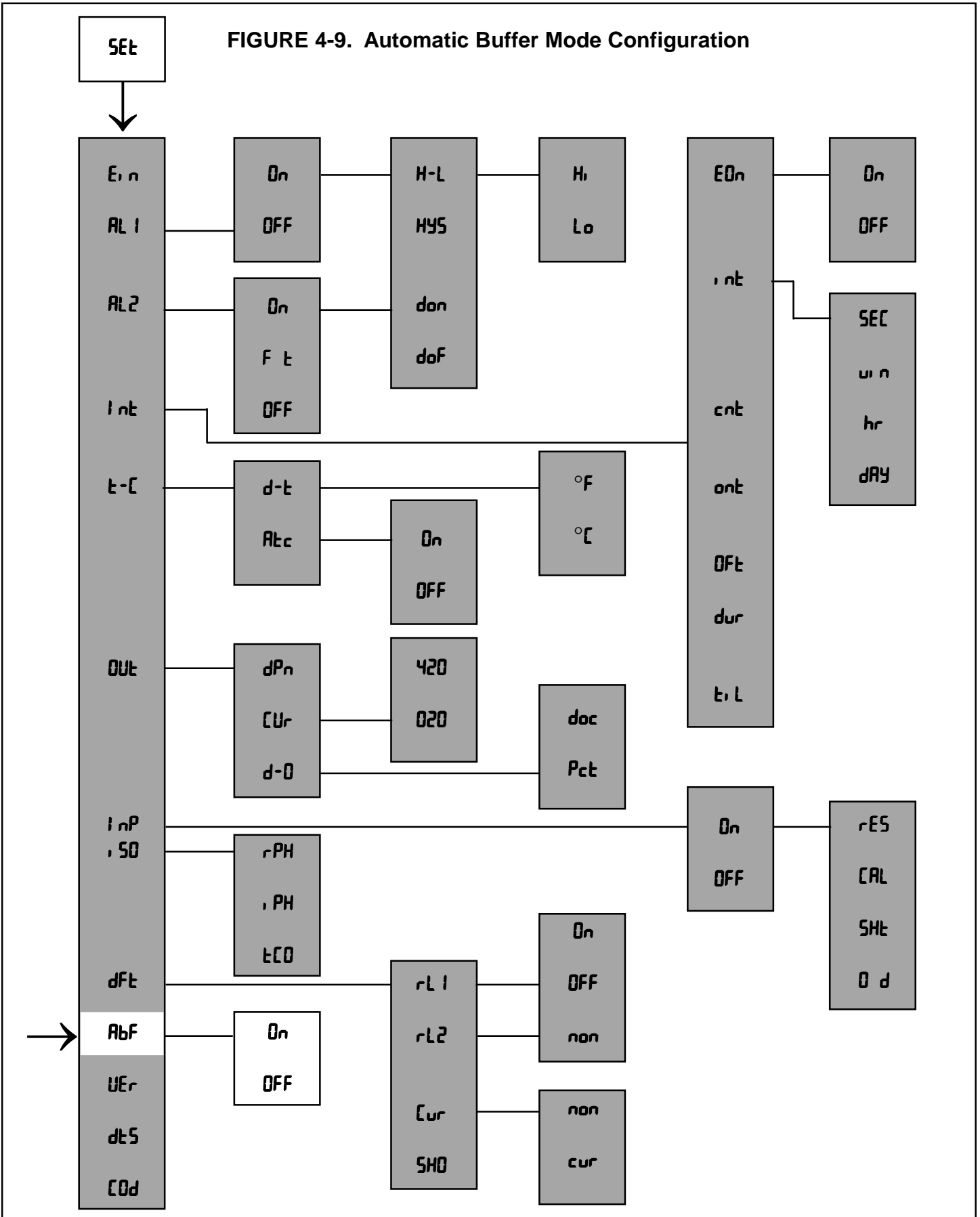

4.10 Alarm Setpoint. The alarm setpoints should be adjusted after completing the configuration procedure as outlined in Sections 4.2 to 4.9.

1. Press the **pH** key to ensure that the transmitter is not in Set Mode.
2. Press the **ALARM 1** or **ALARM 2** key. "SP 1" or "SP 2" will show briefly, followed by the Alarm 1 or Alarm 2 setpoint.

NOTE

If the alarm is set to OFF or FAULT (Alarm 2 only), the transmitter will display "OFF" or "FLT" respectively. (Refer to Section 4.2.2, Alarm Setup.)

3. **SELECT** to adjust the value. The display will acknowledge briefly with "Adj" followed by the Numeric Display with digit flashing.
4. **SCROLL (▲)** and **SELECT (◀)** to display the desired value.
5. **ENTER** value into memory.
6. Repeat Steps 2 to 5 for the second setpoint.

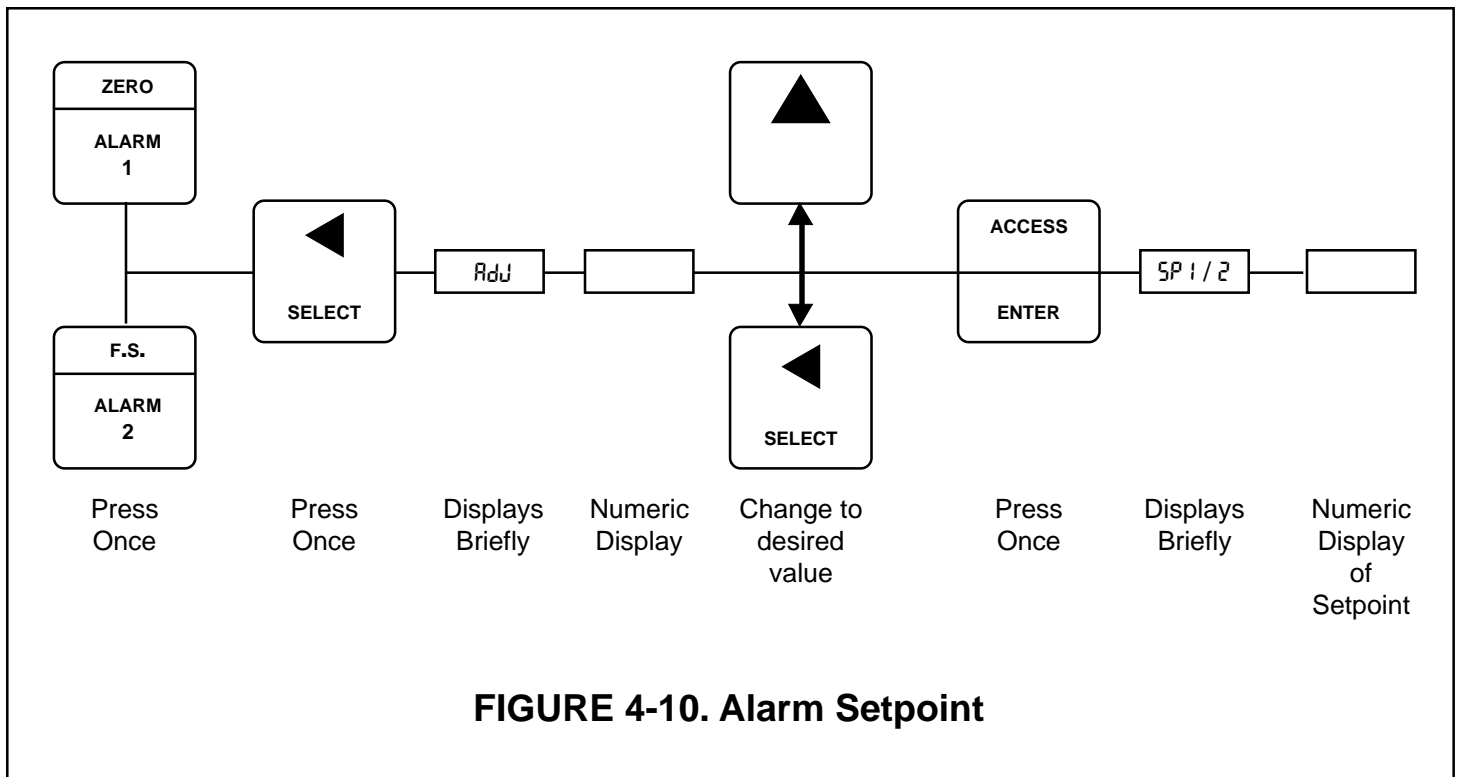

FIGURE 4-10. Alarm Setpoint

4.11 Output Scale Expansion. This section should be followed if it is desired to scale the current output to an operating range other than the factory setting of 0-14 pH full scale. The output zero and full scale value should be adjusted after completing the configuration procedure as outlined in Sections 4.2 to 4.9.

A. Zero Point (0 mA or 4 mA)

1. Press the **pH** key to ensure that the transmitter is not in Set Mode.
2. Press the **ALARM 1** key twice. The display will show "LO" briefly then display ZERO point.
3. **SELECT** to adjust the value. The display will acknowledge briefly with "Adj" followed by the Numeric Display with digit flashing.
4. **SCROLL (▲)** and **SELECT (◀)** to display the desired value.
5. **ENTER** value into memory. The display will show "LO" and display the entered value.

B. Full Scale (F.S.) Point (20 mA)

1. Press the **pH** key to ensure that the transmitter is not in Set Mode.
2. Press the **ALARM 2** key twice. The display will show "Hi" briefly then display FULL SCALE point.
3. **SELECT** to adjust the value. The display will acknowledge briefly with "Adj" followed by the Numeric Display with digit flashing.
4. **SCROLL (▲)** and **SHIFT (◀)** to display the desired value.
5. **ENTER** value into memory. The display will show "Hi" and display the entered value.

NOTE

For a reverse output, enter the higher value for zero, and the lower value for the Full Scale.

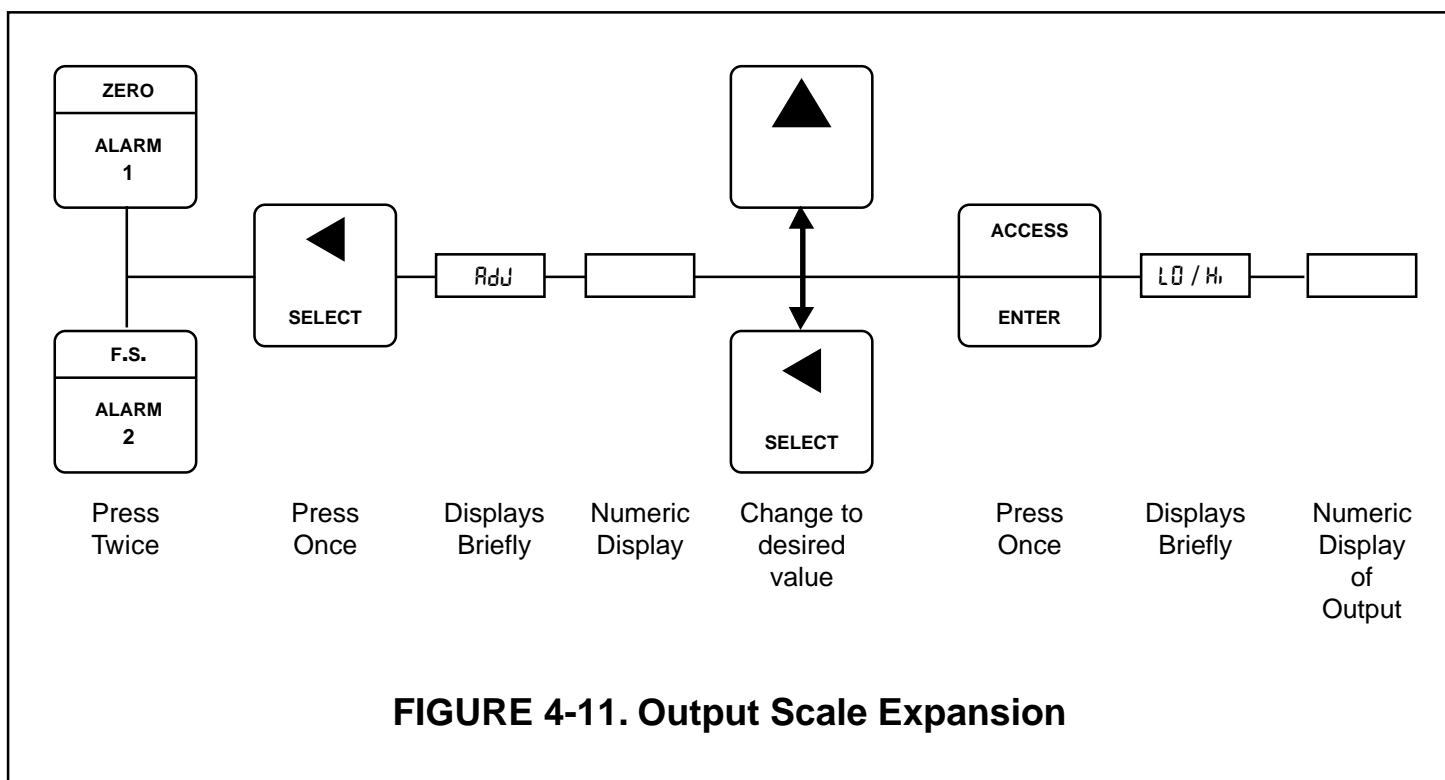

FIGURE 4-11. Output Scale Expansion

4.12 Simulate Current Output. The output can be simulated to check the operation of devices such as valves, pumps, or recorders. The output can be simulated in either current (mA) or percent of full scale, depending on how the output display, "d-B", was configured in Section 4-5. (Refer to Figure 4-12.)

A. Simulate Output in Percent "S, P". The output can be simulated in percent if "d-B" in Section 4.5 was configured to display percent "Pct".

1. Press the **pH** key once to insure that the transmitter is not in the Set Mode.
2. Press **OUTPUT** key twice. The display will show "Pct" briefly, then display the output value in percent of full scale.
3. Press the **SELECT** (◀) to simulate the output. The display will briefly acknowledge with "S, P" followed by the Numeric Display with digit flashing.
4. **SCROLL** (▲) and **SELECT** (◀) to display the desired value.
5. **ENTER** value into memory. The display will show "Pct" and display the entered value. Also, the display will flash to acknowledge that the transmitter is placed on hold "HLD".

6. To remove the transmitter from hold, press the **HOLD** key twice. The hold flag on the display will be removed and the display will stop flashing.

B. Simulate Output in Current "S, I". The output can be simulated in mA units if "d-B" in Section 4.5 was configured to display current "doc".

1. Press the pH key once to insure that the transmitter is not in the Set Mode.
2. Press the **OUTPUT** key twice. The display will show "doc" briefly, then display the output value in mA.
3. Press **SELECT** (◀) to simulate the output. The display will briefly acknowledge with "S, I" followed by the Numeric Display with digit flashing.
4. **SCROLL** (▲) and **SELECT** (◀) to display the desired value.
5. **ENTER** value into memory. The display will show "doc" and display the entered value. Also, the display will flash to acknowledge that the transmitter is placed on hold "HLD".
6. To remove the transmitter from hold, press the **HOLD** key twice. The hold flag on the display will be removed and the display will stop flashing.

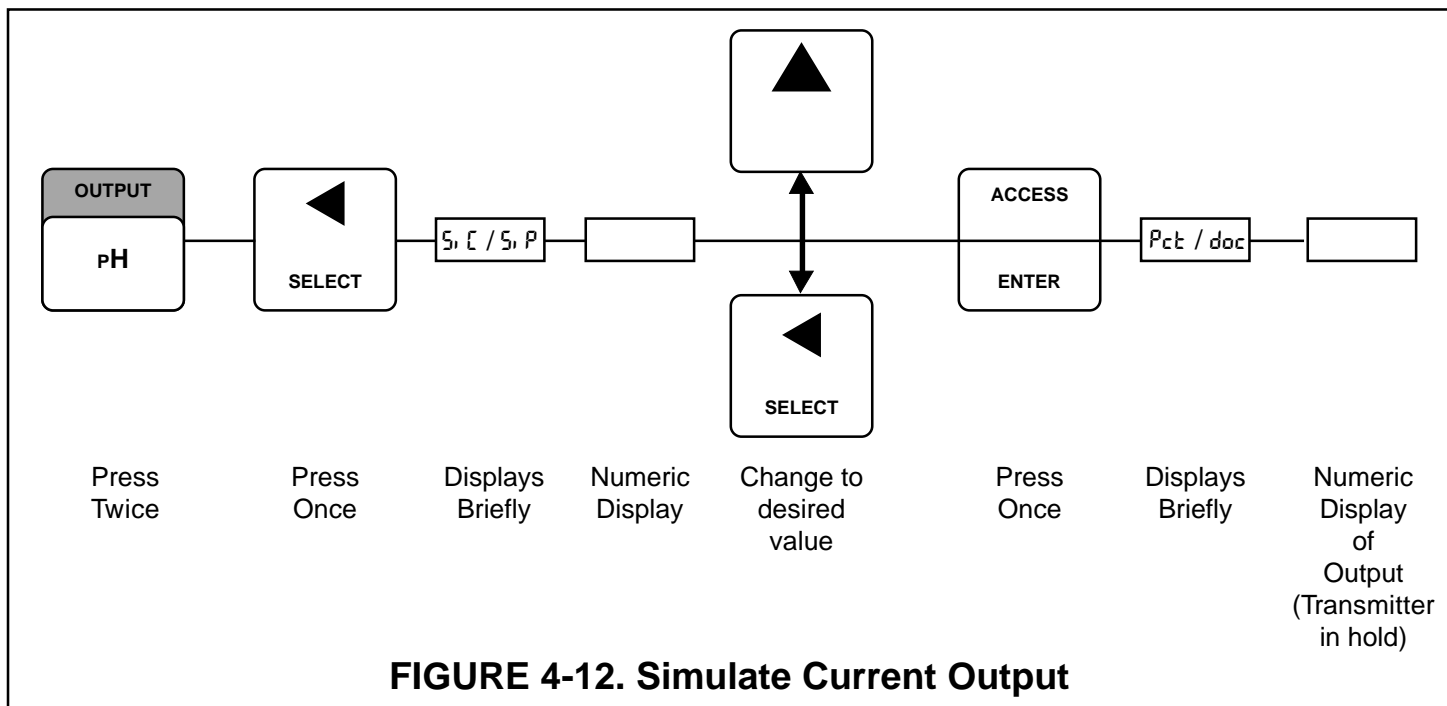

SECTION 5.0 START-UP AND CALIBRATION

5.1 Start-Up and Calibration. Calibration and operation of the Model 10-P-03 should begin only after completion of configuration of the transmitter. The sensor must be wired to the Model 10-P-03 for calibration.

5.2 Temperature Calibration. For accurate temperature correction, the temperature reading may need adjusting. The following steps should be performed with the sensor in a grab sample or in the process. For the best accuracy, the standardization should be performed at or near the process temperature.

1. Observe the transmitter temperature reading by pressing the **TEMP** key. Allow the reading to stabilize to insure that the sensor has acclimated to the process temperature.
2. Compare the reading to a calibrated temperature reading device. If the reading requires adjusting, proceed to Step 3.
3. Press the **TEMP** key then the **SELECT** key to correct the temperature display. The transmitter will display "RdJ" briefly, then the Numeric Display will show with digit flashing.
4. **SCROLL (▲)** and **SELECT (◀)** to key in the correct value and **ENTER** it into memory. Proceed to Section 5.3.

5.3 Buffer Calibration. The two buffer calibration will calculate the slope (efficiency) of the pH sensor and standardize the reading on the second buffer (computed slope limits: 47.3 to 59.9 mV/pH). The transmitter has been set at the factory for automatic calibration. If the software setting has been changed to disable this feature in section 4.9 proceed to section 5.3.2. Otherwise, proceed to section 5.3.1.

5.3.1 Automatic Calibration

1. Press the **HOLD** key twice to place the transmitter in hold.
2. Obtain two buffer solutions with values at least two pH units apart. Unopened buffers have a shelf life of about a year and once opened should not be reused because of contamination.

3. Shake the sensor down to remove entrapped air bubbles from the glass electrode tip.
4. Place the sensing portion of the pH sensor into a beaker containing the first (7.0 pH) buffer solution. Allow the pH reading to stabilize. This may take several minutes, as the pH sensor may need to cool down to the buffer temperature. If you don't wait long enough you may get a slope error.
5. Press the **CAL** key. "Rb I" will flash briefly, followed by a flashing pH buffer value at 25°C (If "Rb2" appears, press the **CAL** key again for "Rb I").
6. If the value displayed is not the value of your buffer at 25°C (see section 4.9) press the **SCROLL (▲)** key until your choice appears. **ENTER** the value.
7. Remove the sensor from the buffer, then rinse and dry it. Place it in the second buffer. Allow the pH reading to stabilize. This may take several minutes, as the pH sensor may need to cool down to the buffer temperature. If you don't wait long enough you may get a slope error.
8. Press the **CAL** key again. "Rb2" will display briefly, followed by a flashing pH buffer value at 25°C. (If "Rb I" appears, press the **CAL** key again for "Rb2").
9. If the value displayed is not the value of your buffer @ 25°C, press the **SCROLL (▲)** key until your choice appears. **ENTER** the value.
10. Press the **HOLD** key twice again to remove the transmitter from hold.
11. In the future the selected buffers will be recognized by the transmitter and can be used for either "Rb I" or "Rb2".
12. For maximum accuracy, perform a process standardization after a buffer calibration (see Section 5.4). Also, you can track your electrode slope value after a buffer calibration to see how the electrode is aging (see Section 5.5).

5.3.2 Calibration With Automatic Features Disabled.

1. Press the **HOLD** key twice to place the transmitter in hold.
2. Obtain two pH buffer solutions with values at least two pH units apart. Unopened buffers have a shelf life of about a year and once opened they should not be reused because of contamination.
3. Shake the sensor down to remove entrapped air bubbles from the pH glass electrode tip.
4. Place the sensing portion of the pH sensor into a beaker containing the first (7.0 pH) buffer solution.
5. Allow the pH reading to stabilize. This may take several minutes, as the pH sensor may need to cool down to the buffer temperature. If you don't wait long enough you may get a slope error. Then note the temperature and find the buffer value at that temperature. Buffer values at various temperatures are located on the label of most buffer bottles.
6. Press the **CAL** key once. "bF I" will display briefly, followed by the Numeric Display with digit flashing. If "bF2" displays, press the **CAL** key again.
7. **SCROLL** (▲) and **SELECT** (◀) to key in the buffer solution value, then **ENTER** it into memory.
8. Remove the sensor from the buffer, rinse and dry it.
9. Place the sensing portion of the pH sensor into a beaker containing the second buffer solution.
10. Allow the pH reading to stabilize. See note in step 5.
11. Press the **CAL** key once. "bF2" will display briefly, followed by the Numeric Display with digit flashing. If "bF I" displays, press the **CAL** key again.
12. **SCROLL** (▲) and **SHIFT** (◀) to key in the buffer solution value, then **ENTER** it into memory.
13. Press the **HOLD** key twice to remove the transmitter from hold.
14. For maximum accuracy, perform a process standardization after a buffer calibration (see Section 5.4). Also, you can track your electrode slope value after a buffer calibration to see how the electrode is aging (see Section 5.5).

5.4 pH Standardization. For maximum accuracy, the sensor should be standardized on-line via a process grab sample after a buffer calibration to account for the sensor junction potential. This sensor standardization technique will not calculate the sensor's slope.

1. Take a grab sample which is as close to the sensor as possible. Write down the value the Transmitter is reading at this time.
2. Using a calibrated pH instrument with automatic temperature compensation, determine the pH of the process grab sample. The calibration is best performed at the process temperature. Write down this value. (If the sample pH is >6.5 and the lab sample is run at a substantially different temperature than the process, see section 4.7).
3. Before entering the standardized value, compare the value the transmitter is reading now to the value in Step 1. Add this change to the reference value obtained in Step 2. This accounts for any change while the grab sample is being measured.
4. Press the **pH** key once, then press the **SELECT** key. "5t8" will show followed by the Numeric Display with digit flashing.
5. **SCROLL** (▲) and **SELECT** (◀) to key in the corrected reference pH value determined in Step 3 then **ENTER** it into memory.

5.5 pH Glass Slope. The slope/efficiency of the glass electrode can be displayed or entered directly (if known) without buffer calibrating (A new electrode has a slope of about 59 mV/pH. As electrode ages the slope will decrease to about 47-49 mV/pH).

1. Press the **CAL/SLOPE** key twice, then the **SELECT** key once.
2. **SCROLL** (▲) and **SELECT** (◀) to key in the correct value then **ENTER** it into memory.

5.6 Sensor Maintenance. Before performing buffer checks or maintenance of the sensor, the transmitter should be placed in hold. This will place the current output and relays in the state set in the default setup (Section 4-8). Press the **HOLD** key twice. The hold flag will show to indicate the hold condition. Always calibrate after cleaning or repair of the pH sensor. (Refer to Sections 5.1.2 and 5.1.3.) After installing the sensor back in the process, press the **HOLD** key twice again to remove the transmitter from hold.

NOTE

To clean the pH sensor, rinse the measurement surfaces with clean tap water followed by cleaning with a warm water and a liquid detergent solution. It may also be necessary to clean with a diluted acid/base or solvent followed with another cleaning with the

water/detergent solution. Avoid scratching or abrading the surface of the glass bulb. Thoroughly rinse sensor to remove all traces of the cleaning solutions. For additional instructions, please refer to the instructions provide with the pH sensor.

SECTION 6.0 KEYBOARD SECURITY

6.1 Keyboard Security. Display Mnemonic “**LOCK**”. Select this feature to display the user defined security code. Any three digit number may be used for this code. “**OFF**” will disable the security feature. This item is used to prevent accidental changes to the calibration and configuration of the transmitter. When activated, the transmitter will allow all read functions to read normally. If an attempt is made to change a value, “**LOC**” will display followed by the Numeric Display ready for the code to be entered. A proper code will unlock the transmitter and will return to the last function attempted. Any incorrect value will result in “**ERR**” briefly displaying. The transmitter will then return to numeric display and await the entry of the code. Once unlocked, the transmitter will allow access to all functions until the transmitter is either powered down or no keystrokes are made for a period of 2 minutes. If the code should be forgotten, pressing and holding the **ACCESS** key for 5 seconds will result in display of the code. Releasing the **ACCESS** key, then pressing **ENTER** will unlock the transmitter.

6.1.2 Keyboard Security (LOCK).

1. Enter Set Mode by pressing **ACCESS** key twice.
2. **SCROLL** (▲) until “**LOCK**” appears on the display.
3. **SELECT**.
4. **SCROLL** (▲) and **SELECT** (◀) to display the desired value, then **ENTER** it into memory.

NOTE

Entering “**OFF**” disables the keyboard security.

NOTE

Security feature will not activate until 2 minutes without keyboard activity or power is removed from the transmitter then restored.

SECTION 7.0 THEORY OF OPERATION

7.1 THEORY OF OPERATION. This section is a general description of how the Model 10-P-03 operates. This section is for those users who desire a greater understanding of the transmitter's operation.

The measurement of the process' pH is accomplished by the use of two electrodes within the sensor. The glass electrode is pH sensitive and generates a high impedance millivolt potential directly proportional to the process pH. The reference electrode is a second half cell that completes the circuit via a liquid junction. The high impedance signal is preamplified as

close to the sensor as possible to allow a stable noise-free pH signal that can be transmitted up to 1,000 feet between the preamplifier and the transmitter.

The Model 10-P-03 also measures the process temperature via a platinum 100 ohm RTD imbedded inside the glass electrode portion of the sensor. The transmitter uses this temperature measurement to compensate for changes in the glass electrode millivolt output caused by temperature change. Advanced circuitry is used to eliminate errors due to changes in cable resistance.

SECTION 8.0 DIAGNOSTICS AND TROUBLESHOOTING

8.1 Diagnostics. The Model 10-P-03 has a diagnostic feature which automatically searches for fault conditions that would cause an error in the measured pH value. If such a condition occurs, the current output and relays will act as configured in Section 4-8 and the fault flag and display will flash. A fault code mnemonic will display at frequent intervals. If more than one fault condition exists, the display will sequence the faults at one second intervals. This will continue until the cause of the fault has been corrected. Display of fault mnemonics is suppressed when in Set Mode. Selecting the "5H0" item will display a history of the two most recent fault conditions unless "5H0" was cleared. Refer to Section 4.8C.

NOTE

If the transmitter is in hold and a fault occurs, the mnemonic "HLd" will display during the fault sequence.

8.1.1 Fault Mnemonics. Table 8-1 lists the fault mnemonics and describes the meaning of each.

8.1.2 Temperature Compensation. Table 8-2 is a ready reference of RTD resistance values at various temperatures. These are used for test and evaluation of the sensor.

NOTE

Ohmic values are read across the RTD element and are based on the manufacturer's stated values ($\pm 1\%$). Allow enough time for the RTD element to stabilize to the surrounding temperature.

TABLE 8-1. Fault Mnemonics

Display	Description	Display	Description
ERL	Warning to calibrate or clean sensor,	Ed	Electrode worn out, coated, or non-immersed.
EHS	ROM failure (check sum error) (bad ROM chip).	SEn	Sensor line error or wire length error.
EDP	Computer not operating properly.	5HE	Glass electrode cracked or broken.
EFP	EEPROM write error (bad EEPROM chip).	SLP	Slope variance error.
FRE	Factory calibration required.	EcH	High temperature compensation error.
INH	Input shorted.	EcL	Low temperature or shorted RTD.
INL	Sensor miswired.		

TABLE 8-2. RTD Resistance Values

Temperature	Resistance	Temperature	Resistance
0°C	100.00 ohms	50°C	119.40 ohms
10°C	103.90 ohms	60°C	123.24 ohms
20°C	107.79 ohms	70°C	127.07 ohms
25°C	109.73 ohms	80°C	130.89 ohms
30°C	111.67 ohms	90°C	134.70 ohms
40°C	115.54 ohms	100°C	138.50 ohms

8.2 Troubleshooting. The Model 10-P-03 Transmitter is designed with state-of-the-art microprocessor circuitry, making troubleshooting simple and direct. Sub-assembly replacement, i.e. printed circuit board replacement, is all that is usually required.

8.2.1 Installation Failure. If failure does occur, complete the following steps:

1. Check for a fault flag. If a fault condition exists, refer to Table 8-1 for the fault mnemonic explanation.
2. Check wiring connections for proper installation.
3. Refer to Troubleshooting Table 8-3. The table is arranged with the most common problems listed first.

8.2.2 LED Display Test. Display Mnemonic “dE5”. Selecting this option will activate all the display segments. This item is used if a faulty display is suspected. Refer to Figure 3-1 Keyboard Overlay.

1. Enter Set Mode by pressing **ACCESS** key twice.
2. **SCROLL** (▲) until “dE5” appears on the display.
3. **SELECT**.

8.2.3 Software Version. Display Mnemonic “uEr”. Selection of this item will display the software revision level of the CPU. This number may be requested by factory service personnel if troubleshooting is required.

1. Enter Set Mode by pressing **ACCESS** key twice.
2. **SCROLL** (▲) until “uEr” appears on the display.
3. **SELECT**. (i.e., 2.0.6 displayed.)

8.2.4 Sensor Troubleshooting. In addition to the fault mnemonics that relate to a possible sensor problem (Tables 8-1 and 8-3), the transmitter can display the input in millivolts generated from the sensor. See Table 8-4 for how the millivolt input relates to pH. If the transmitter values do not agree within about 40 to 60 mV of those in the table, the transmitter has been incorrectly standardized for pH, the reference may be significantly poisoned, or some other significant problem exists. To read the millivolt input, go to 8.2.5.

For an additional diagnostics tool you can look at the “rE5” impedance value as described in Section 4.6.

8.2.5 Electrode Input. Display Mnemonic “E, n”. When selected, the transmitter displays the millivolt input from the sensor. The displayed value is not temperature corrected.

1. Press the **ACCESS** key twice. “E, n” will briefly display followed by “E, n”. Not required if already in set menu.
2. **SELECT** this item to read the mV input.
3. Press the **pH** key to return to normal operation.

8.2.6 CPU Board Replacement. If there is a problem with the CPU board resulting in its replacement, specific procedures (included with the order) for calibrating the new board must be followed exactly or the microprocessor will be improperly programmed. Should this occur, it will be necessary to return the transmitter to the factory for reprogramming.

8.2.7 Power Board Replacement. If it becomes necessary to replace the power board, the CPU board will need to be recalibrated following specific procedures that are included with the power board. Failure to follow these procedures exactly will cause the microprocessor to be improperly programmed and require the return of the transmitter to the factory for reprogramming.

TABLE 8-4
Sensor Input to Transmitter Verses
pH at Four Temperatures *

pH	Input to Transmitter in Millivolts			
	15°C (59°F)	25°C (77°F)	50°C (122°F)	80°C (176°F)
0	396	414	444	486
1	340	355	381	416
2	283	295.8	317	347
3	226	236.6	254	277
4	170	177.5	190	208
5	113.2	118.3	127.0	138.7
6	56.6	59.16	63.5	69.4
7	0	0	0	0
8	-56.6	-59.16	-63.5	-69.4
9	-113.2	-118.3	-127.0	-138.7
10	-170	-177.5	-190	-208
11	-226	-236.6	-254	-277
12	-283	-295.8	-317	-347
13	-340	-355	-381	-416
14	-396	-414	-444	-486

* These values do not apply for non-glass electrodes

TABLE 8-3. Troubleshooting Guide

SYMPTOM	PROBLEM	ACTION
Fault code "FL".	<ol style="list-style-type: none"> Warning to calibrate sensor with buffers. Electrode is aging or coated. Electrode is not in solution. 	<ol style="list-style-type: none"> Calibrate with buffers (First clean if necessary.). Immerse electrode in solution.
Fault code "SH". pH is a constant value in any buffer. "rE5" value less than 70% of normal.	<ol style="list-style-type: none"> Glass electrode broken. 	<ol style="list-style-type: none"> Replace electrode/sensor.
Fault code "D d".	<ol style="list-style-type: none"> Electrode is worn out or coated. If electrode is worn out, "SLP" will also be low and the electrode sluggish. Electrode is not in solution. 	<ol style="list-style-type: none"> Replace or clean electrode as soon as possible. Immerse electrode in solution.
"E n" increasingly greater or less than zero mV at 7pH, with increased poisoning.	<ol style="list-style-type: none"> Reference becoming poisoned. Asymmetry Potential of glass electrode is out of specification. 	<ol style="list-style-type: none"> Replace reference or sensor. Request a special DynaProbe® sensor if necessary.
pH value locks up (no change of pH value in two buffers).	<ol style="list-style-type: none"> Glass electrode cracked. Coated glass electrode. Junction plugged. 	<ol style="list-style-type: none"> Replace glass electrode/sensor. Clean glass electrode. Replace junction/sensor.
10 pH value not the same as grab sample of process.	<ol style="list-style-type: none"> Grab sample incorrect. Unclear what is correct. Transmitter out of calibration. 	<ol style="list-style-type: none"> Re-evaluate sample technique and equipment. Test with buffer solution. Recalibrate per start-up and calibration section.
Fault code "tCH"/"tCL".	<ol style="list-style-type: none"> Miswired or temperature out of range. Open or shorted RTD. 	<ol style="list-style-type: none"> Check wiring between the sensor and transmitter. Check process temperature. Replace RTD/sensor.
Fault code "i nH" or "i nL".	<ol style="list-style-type: none"> Open wire from preamplifier. Defective preamplifier. Defective CPU. 	<ol style="list-style-type: none"> Check wiring between preamplifier and transmitter. Replace preamplifier. Replace CPU PCB.
Fault code "SLP".	<ol style="list-style-type: none"> Defective electrode/sensor. Improper buffer calibration. Coated electrode. Plugged liquid junction. 	<ol style="list-style-type: none"> Replace electrode/sensor. Recheck buffer accuracies. Clean or replace electrode/sensor. Replace junction/sensor.
Fault code "SEn".	<ol style="list-style-type: none"> Open wire between sensor and transmitter. Cable length has exceeded Maximum length: 1000 ft. after preamp. 	<ol style="list-style-type: none"> Repair wire. Check wiring.
Fault code "EEP".	<ol style="list-style-type: none"> Defective EEPROM. 	<ol style="list-style-type: none"> Replace CPU PCB.
Fault code "EH5".	<ol style="list-style-type: none"> Defective CPU. 	<ol style="list-style-type: none"> Replace CPU PCB.
No alarm relay closure.	<ol style="list-style-type: none"> Defective power board. Defective CPU. 	<ol style="list-style-type: none"> Replace power PCB. Replace CPU PCB.
No output current.	<ol style="list-style-type: none"> Defective output board. Miswire. 	<ol style="list-style-type: none"> Replace power PCB. Check for short.
Low output current.	<ol style="list-style-type: none"> Circuit loading with excessive resistance on output. 	<ol style="list-style-type: none"> Consult output loading limits Model 10 pH specifications: (600 ohms max load).

TABLE 8-5. Replacement Parts and Accessories

P/N	DESCRIPTION	P/N	DESCRIPTION
AM-9227	Gasket, Rear cover	AM-9254	Front Panel MODEL 10-P
AM-9228	Gasket, Front Cover	AM-9260	Fuse, 0.1A, 3AG, 250V, Slo Blo
AM-9229	PCB, Power Supply	AM-9295	Enclosure
AM-9248	PCB, Mother Board	AM-9296	Enclosure, Rear Cover
AM-9252	PCB, LED Digital Display	AM-9297	PCB, CPU BJC pH

TABLE 8-6. Ordering Information

The **Model 10-P-03 Microprocessor Transmitter** is housed in a NEMA 4X weatherproof, corrosion-resistant housing suitable for panel, pipe or wall mounting. The transmitter operates on 115 / 230 VAC, 60 Hz. Standard features include an LED digital display, continuous self diagnostics, isolated current output, dual alarms, and automatic temperature compensation.

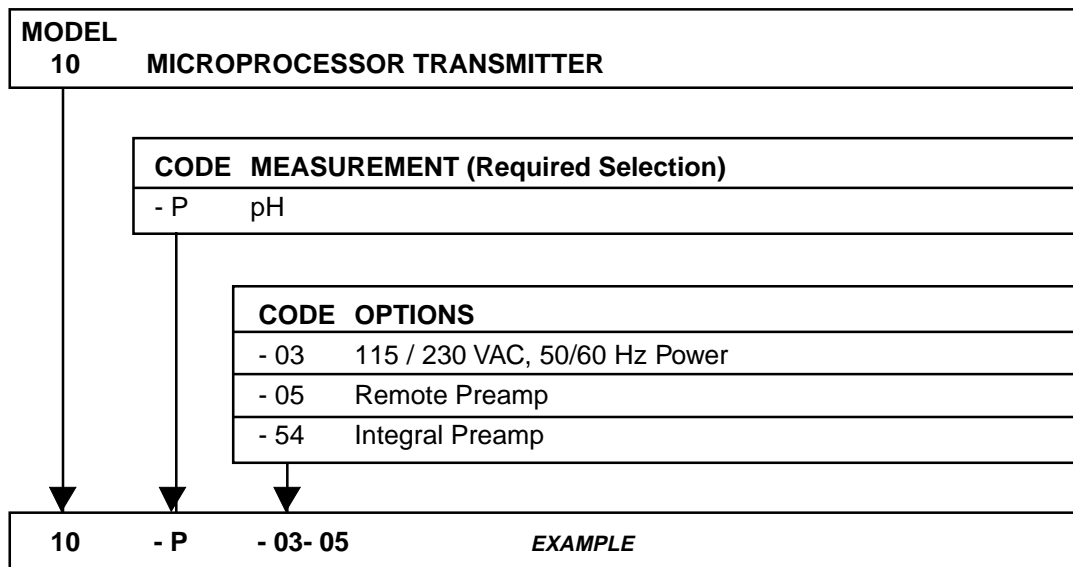

NOTE: PREAMP CODE -05 OR CODE -54 MUST BE SELECTED

TABLE 8-7. Accessory Ordering Information

The **Model 10-P-03 Microprocessor Transmitter** will provide better performance in certain applications when the appropriate accessory item is included. It is recommended that the Remote Preamp be mounted inside one of the two junction box accessories listed below.

P/N	ACCESSORIES
AM-9240	Remote Preamp
PS-100	Junction Box with Sensor Quick Disconnects and Signal Output Cable Grip
PS-120	Junction Box, with Sensor Inlet and Signal Output Cable Grips
AM-9224	Wall Mounting Plate with Junction Box (only available with Code - 05)
AM-9223	Two-inch Pipe Mounting Bracket
AM-9249	Stainless Steel Tag (specify marking)

SECTION 9.0 RETURN OF MATERIALS

9.1 GENERAL.

To expedite the repair and return of sensors, proper communication between the customer and the factory is important. A return material authorization (RGM number) is required. Call (714) 829-5555 or FAX (714) 829-5560. The "Return Goods Memo" form is provided for you to copy and use in case the situation arises. The accuracy and completeness of this form will help to expedite the processing time of your materials.

9.2 WARRANTY REPAIR.

The following is the procedure for returning products still under warranty.

1. Contact the factory for authorization..
2. Complete a copy of the "Return Goods Memo" form as completely and accurately as possible.
3. To verify warranty, supply the factory sales order number or the original purchase order number.
4. Carefully package the materials and enclose the completed copy of the "Return Goods Memo" form. If possible, pack the materials in the same manner as received.

IMPORTANT

Please see second section of the "Return Goods Memo" form. Compliance to the OSHA requirements is mandatory for the safety of all personnel. MSDS forms and a certification that the sensors have been disinfected or detoxified are required.

5. Send the package prepaid to:

Broadley-James Corporation

19 Thomas

Irvine, CA 92618

Attn: Factory Repair

Mark the package:

Returned for Repair RGM No. _____

Model No. _____

9.3 NON WARRANTY REPAIR.

1. Contact the factory for authorization.
2. Fill out a copy of the "Return Goods Memo" form as completely and accurately as possible.
3. Include a purchase order number and make sure to include the name and telephone number of the right individual to be contacted should additional information be needed.
4. Do Steps 4 and 5 of Section 9.2.

NOTE:

Consult the factory for additional information regarding service or repair.

RETURN OF MATERIALS REQUEST

●IMPORTANT!

This form must be completed to insure expedient factory service

CUSTOMER	RETURN TO: _____	BILL TO: _____
	_____	_____
	_____	_____
KEY CONTACT		
NAME _____		PHONE _____
ADDRESS _____		

NOTICE TO SENDER

CUSTOMER/USER MUST SUBMIT MATERIAL SAFETY SHEET (MSDS) OR COMPLETE STREAM COMPOSITION, AND/OR LETTER CERTIFYING THE MATERIALS HAVE BEEN DISINFECTED AND/OR DETOXIFIED WHEN RETURNING ANY PRODUCT, SAMPLE OR MATERIAL THAT HAS BEEN EXPOSED TO OR USED IN AN ENVIRONMENT OR PROCESS THAT CONTAINS A HAZARDOUS MATERIAL. **ANY OF THE ABOVE THAT IS SUBMITTED TO BROADLEY-JAMES CORPORATION WITHOUT THE MSDS WILL BE RETURNED TO SENDER C.O.D.** FOR THE SAFETY AND HEALTH OF OUR EMPLOYEES. WE THANK YOU IN ADVANCE FOR COMPLIANCE TO THIS SUBJECT.

COMPONENT OR SUB-ASSEMBLY:	MODEL NUMBER:	SERIAL NUMBER:
1. PART NO. _____	1. MODEL _____	1. SER NO. _____
2. PART NO. _____	2. MODEL _____	2. SER NO. _____
3. PART NO. _____	3. MODEL _____	3. SER NO. _____

REASON FOR RETURN

PLEASE CHECK APPROPRIATE BOX(ES):

<input type="checkbox"/> WRONG PART RECEIVED	<input type="checkbox"/> WARRANTY REQUEST
<input type="checkbox"/> DUPLICATE SHIPMENT	<input type="checkbox"/> NON-WARRANTY (CUSTOMER P.O.# _____)
<input type="checkbox"/> REPAIR AND CALIBRATE	<input type="checkbox"/> DEMO EQUIPMENT NO. _____
<input type="checkbox"/> EVALUATION	<input type="checkbox"/> OTHER (EXPLAIN) _____
<input type="checkbox"/> REPLACEMENT REQUIRED	_____

DESCRIPTION OF APPLICATION: _____

DESCRIPTION OF MALFUNCTION: _____

REPAIR STATUS

YES/ REFERENCE ORIGINAL BROADLEY-JAMES ORDER NO. _____

CUSTOMER REPAIR PURCHASE ORDER NO. _____

NO/ CONTACT WITH ESTIMATE OF REPAIR CHARGES: _____

NAME OF CONTACT: _____

FAX _____

PHONE _____



RGM NUMBER: _____
(ASSIGNED BY THE BJC FACTORY)

WARRANTY

Goods and part(s) manufactured by Seller are warranted to be free from defects in workmanship and material under normal use and service for a period of twelve (12) months from the date of shipment by Seller. Goods and part(s) proven by Seller to be defective in workmanship and / or material shall be replaced or repaired, free of charge, F.O.B. Seller's factory provided that the goods and part(s) are returned to Seller's designated factory, transportation charges prepaid, within the twelve (12) month period of warranty. This warranty shall be in effect for replacement or repaired goods and part(s) for the remaining portion of the period of the twelve (12) month warranty. A defect in goods or part(s) of the commercial unit shall not operate to condemn such commercial unit when such goods and part(s) are capable of being renewed, repaired or replaced.

The Seller shall not be liable to the Buyer, or to any other person, for the loss or damage, directly or indirectly, arising from the use of the equipment or goods, from breach of any warranty or from any other cause. All other warranties, expressed or implied are hereby excluded.

IN CONSIDERATION OF THE STATED PURCHASE PRICE OF THE GOODS, SELLER GRANTS ONLY THE ABOVE STATED EXPRESS WARRANTY. NO OTHER WARRANTIES ARE GRANTED INCLUDING, BUT NOT LIMITED TO, EXPRESS AND IMPLIED WARRANTIES OF MERCHANTABILITY AND FITNESS FOR A PARTICULAR PURPOSE.

RETURN OF MATERIAL

Material returned for repair, whether in or out of warranty, should be shipped prepaid to:

**Broadley-James Corporation
19 Thomas
Irvine, CA 92618 USA**

The shipping container should be marked:

"Return for Repair"

Model: _____

RGM Nr: _____ (must be obtained from the factory prior to return)

The returned material should be accompanied by a letter of transmittal which should include the following information (make a copy of the "Return of Materials Request" found on the last page of the Manual and provide the following thereon):

1. Location type of service, and length of time of service of the device.
2. Description of the faulty operation of the device and the circumstances of the failure.
3. Name and telephone number of the person to contact if there are questions about the returned material.
4. Statement as to whether warranty or non-warranty service is requested.
5. Complete shipping instructions for return of the material.

Adherence to these procedures will expedite handling of the returned material and will prevent unnecessary additional charges for inspection and testing to determine the problem with the device.

If the material is returned for out-of-warranty repairs, a purchase order for repairs should be enclosed.



Artisan Technology Group is your source for quality new and certified-used/pre-owned equipment

- FAST SHIPPING AND DELIVERY
- TENS OF THOUSANDS OF IN-STOCK ITEMS
- EQUIPMENT DEMOS
- HUNDREDS OF MANUFACTURERS SUPPORTED
- LEASING/MONTHLY RENTALS
- ITAR CERTIFIED SECURE ASSET SOLUTIONS

SERVICE CENTER REPAIRS

Experienced engineers and technicians on staff at our full-service, in-house repair center

*InstraView*SM REMOTE INSPECTION

Remotely inspect equipment before purchasing with our interactive website at www.instraview.com ↗

WE BUY USED EQUIPMENT

Sell your excess, underutilized, and idle used equipment. We also offer credit for buy-backs and trade-ins. www.artisanng.com/WeBuyEquipment ↗

LOOKING FOR MORE INFORMATION?

Visit us on the web at www.artisanng.com ↗ for more information on price quotations, drivers, technical specifications, manuals, and documentation

Contact us: (888) 88-SOURCE | sales@artisanng.com | www.artisanng.com