

**burleigh**

**PZL/PZO/PZS**

---

**Operating  
Manual**



**PZL/PZO/PZS  
OPERATING MANUAL**

Operating Manual (Rev. D)  
51518-M-00

Copyright © Burleigh Instruments, Inc. 1999  
All Rights Reserved

**burleigh**

Burleigh Instruments, Inc.  
Burleigh Park  
P.O. Box E  
Fishers, NY 14453-0755  
Tel. (716) 924-9355  
Fax. (716) 924-9072  
Email [info@burleigh.com](mailto:info@burleigh.com)

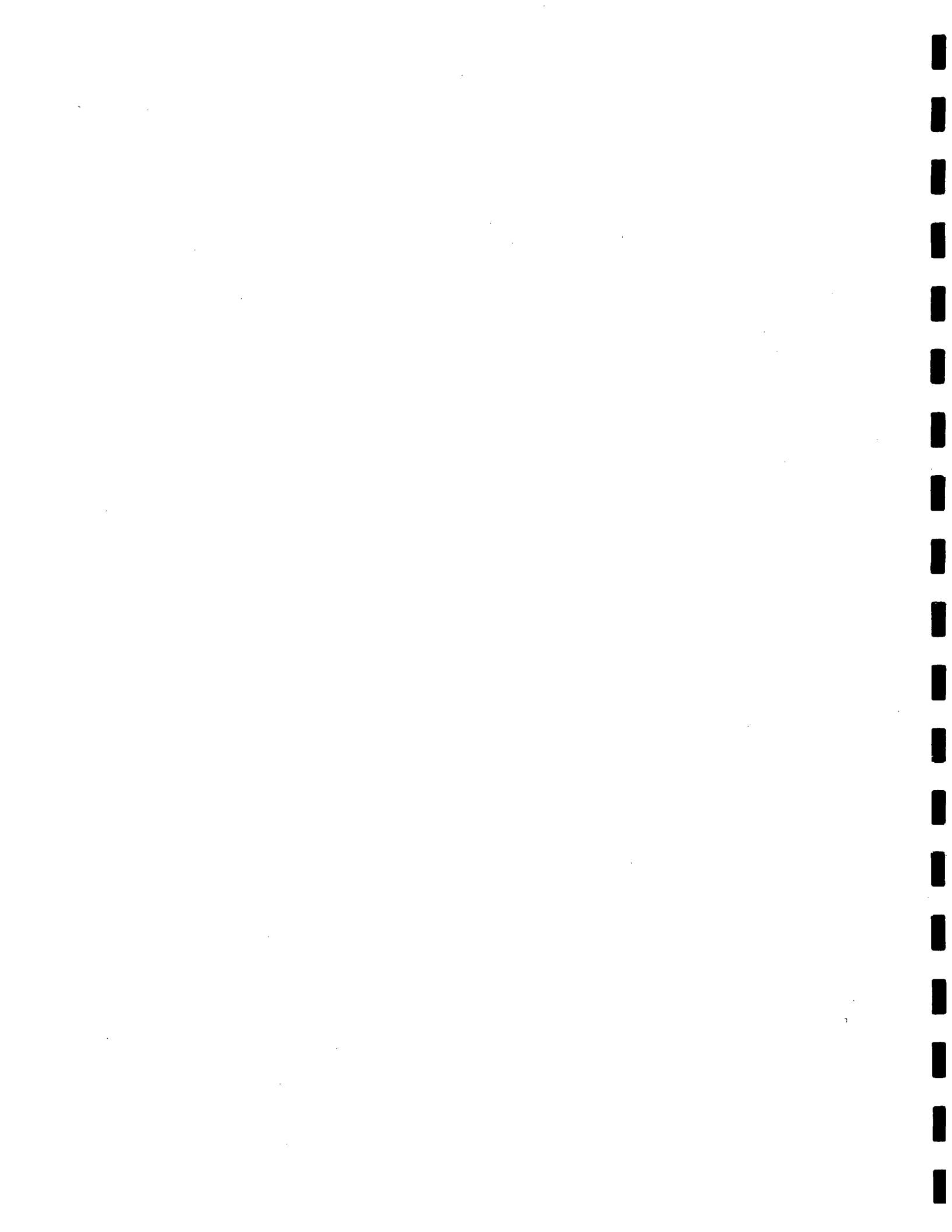

## TABLE OF CONTENTS

<b>1. INTRODUCTION.....</b>	<b>2-1</b>
<b>2. INITIAL INSPECTION.....</b>	<b>2-1</b>
2.1 Visual .....	2-1
2.2 Operational.....	2-1
2.3 Quality Control.....	2-1
<b>3. DEFINITION OF TERMS .....</b>	<b>3-1</b>
<b>4. DESCRIPTION.....</b>	<b>4-1</b>
4.1 Low Voltage Piezoelectric Actuators.....	4-1
4.2 Electronics .....	4-7
<b>5. OPERATION.....</b>	<b>5-1</b>
5.1 Mounting.....	5-1
5.2 Electrical Connections .....	5-2
5.3 User Supplied Electronics .....	5-4
5.4 Performance.....	5-5
5.5 Reliability .....	5-8
<b>6. SERVICE .....</b>	<b>6-1</b>
<b>7. SPECIFICATIONS .....</b>	<b>7-1</b>
7.1 PZO Pushers.....	7-1
7.2 PZL Pushers .....	7-2
7.3 PZS Microstages.....	7-3
<b>8. OPTIONS.....</b>	<b>8-1</b>
8.1 Vacuum Operation (PZL-V, PZS-V) .....	8-1
8.2 Adapter .....	8-3
<b>9. WARRANTY.....</b>	<b>9-1</b>



## 1. INTRODUCTION

Burleigh Instruments thanks you for choosing one of our Low Voltage Piezoelectric Actuators for your positioning needs. By incorporating the latest piezoelectric technology, these actuators provide precision positioning in a compact package with an operating voltage of only 150 volts.

Please contact Burleigh's Customer Service Department at 716-924-9355 or your local representative if you have any questions.

**CAUTION: "Low Voltage" is a relative term. Your PZO, PZL or PZS Low Voltage Actuator operates up to 150 volts which is hazardous. Do not disassemble any of these devices or turn or adjust any housing screws as there are no user serviceable areas or parts inside. Do not use if the cables or plugs are damaged.**

In addition to the Low Voltage Piezoelectric Actuators described in this manual, Burleigh offers a wide range of other positioning devices. These include the PZA-030 (a low voltage piezoelectric micrometer adapter), high voltage (0 to 1000 V) pushers and the Inchworm<sup>®</sup> Motor. Call Burleigh's Sales Department for more information and to determine the actuator best suited to your application.

See Section 4.1 for a complete list of the products covered in this manual.

Inchworm is a registered trademark of Burleigh Instruments, Inc.





## 2. INITIAL INSPECTION

### 2.1 Visual

Burleigh's Low Voltage Piezoelectric Actuators are packed in a carton designed to give maximum protection during shipment. If the outside of the shipping carton is damaged, notify your shipping department immediately. Your shipping department may wish to notify the carrier at this point.

If the shipping carton is undamaged externally, remove the actuator from the carton. If any damage is evident visually or if rattling can be heard when the actuator is gently shaken, notify your shipping department and Burleigh Instruments, Inc. or your local representative immediately. Please save the special carton for future storage and transportation.

### 2.2 Operational

Refer to Sections 5.4 and 7.0 for a discussion of the normal operation of your particular Low Voltage Piezoelectric Actuator. If your actuator fails to operate correctly, contact Burleigh's Customer Service Department or your local representative at once.

### 2.3 Quality Control

Each Low Voltage Piezoelectric Actuator undergoes several stages of inspection and test before shipment, including an extended run-in. They are designed to provide reliable operation for many years. In the unlikely event that you have a problem, please contact Burleigh for instructions. Our Customer Service Department is ready to help with advice, parts, and repair services.



### 3. DEFINITION OF TERMS

These definitions are provided to help clarify the terminology and specifications described in this manual.

**Compliance:** The amount of compression that occurs, under a given load, due to a material's elasticity and is usually expressed in micrometers per kilogram. For Burleigh actuators this is defined for compression only.

**Creep:** The short term dimensional stabilization that occurs in PZT materials following a rapid change in applied voltage. After the voltage is applied to produce the primary motion, secondary motion occurs in the same direction as the primary motion. This secondary motion is the creep and is a characteristic of all piezoelectric materials. Creep is expressed as a percentage of the primary movement and may be affected by the load on the actuator.

**Extension:** The increase in length of the actuator as a function of applied voltage.

**Flexure:** A thin section of material in a larger structure that acts like a hinge due to its elasticity. A flexure typically provides precision frictionless motion in one degree of freedom while rigidly constraining the remaining degrees of freedom.

**Frequency Response:** The useful frequency range of the actuator. For piezoelectric actuators there are two practical considerations which determine the frequency response:

- The current available from the driving electronics.
- The mechanical resonances in the actuator and payload.

As the frequency increases, both of these factors will cause a phase shift between the voltage and motion and attenuate the amplitude (extension) of the motion.

**Hysteresis:** The difference in extension that occurs in PZT materials when a particular voltage is approached from a lower voltage versus from a higher voltage. Hysteresis is the maximum difference in extension for any voltage on the extension versus voltage curve and is expressed as a percentage of the maximum extension.

**Non-linearity:** The deviation from a linear relationship between voltage and extension for PZT materials. The value for non-linearity is derived by drawing a linear least squares fit through the actual extension versus voltage curve. Non-linearity is the maximum deviation between the data and the least squares fit, expressed as a percentage of the maximum extension. It is defined for increasing voltage only.

**Phase Shift:** The difference in phase between the voltage waveform driving a piezoelectric actuator and the mechanical motion.

**Poling:** The process of preparing raw piezoelectric material so that it exhibits a piezoelectric response. Poling is typically achieved by applying a large constant voltage to the PZT for a long period of time at elevated temperature.

**Pusher:** A PZT actuator that provides direct linear motion to an attached load. Direct means without flexures, levers, or other mechanical interfaces.

**PZT:** The acronym for Lead Zirconium Titanate that has become a common designation for all piezoelectric ceramic materials.

**Step response:** The extension of the actuator as a function of time in response to a step change in the input voltage.

**Stiffness:** The inverse of compliance. It is sometimes called the spring rate or spring constant and is usually expressed in newtons per micrometer. For Burleigh actuators this is defined for compression only.

**4. DESCRIPTION**

**4.1 Low Voltage Piezoelectric Actuators**

Burleigh's Low Voltage Piezoelectric Actuators are miniature electromechanical devices. The active PZT element expands when voltage is applied. They are used to make continuous, remote, high resolution positioning adjustments.

Products covered by this manual:

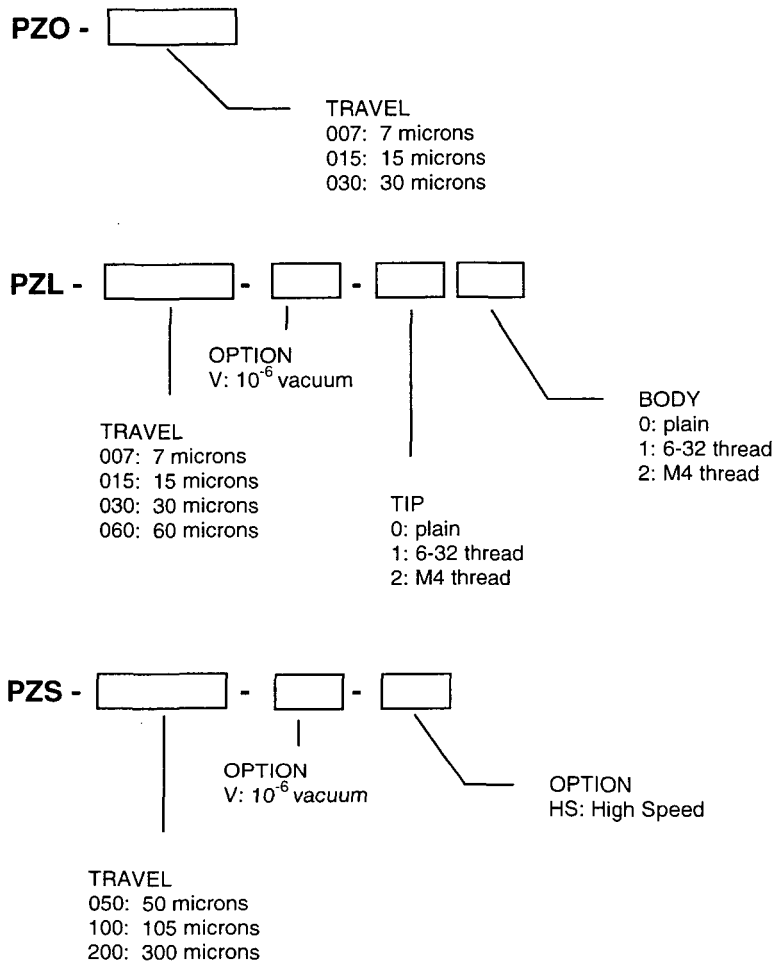

**PZO: (See Figure 4.1)**

Burleigh's PZO pushers are designed for applications requiring compact size and for OEM use. The internal piezoelectric elements are protected in a thin walled stainless steel housing. These devices feature flying leads permanently attached to the actuator for simple electronic connection.

MODEL	LENGTH
PZO-007	0.567
PZO-015	0.961
PZO-030	1.749

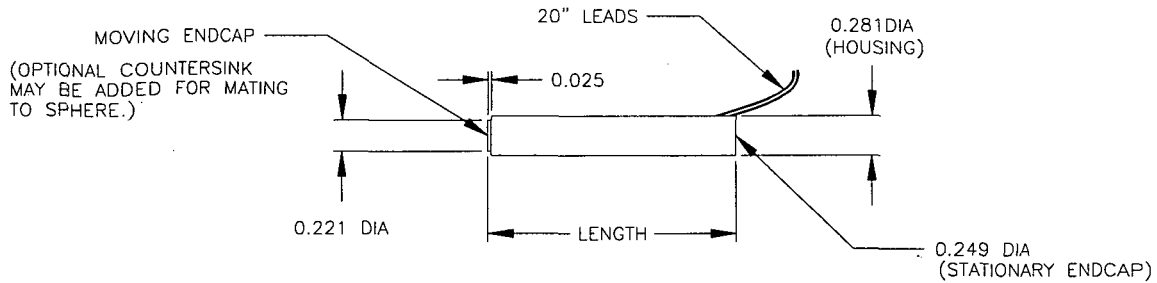

Figure 4.1. PZO Outline Dimensions

**PZL: (See Figure 4.2)**

Burleigh's PZL pushers enclose the piezoelectric element in a rigid nonmagnetic stainless steel housing that allows easy mounting. The housing is designed to maintain a preload on the PZT while isolating the ceramic from lateral and twisting loads. All PZL pushers come equipped with a six foot cable that terminates with a LEMO connector. This connector mates with Burleigh's PZ-150, PZ-300, and PZ-350 Low Voltage Amplifier/Driver electronics. An optional Mini-DIN connector is available for connection to the PZ-100 Step Driver.

These pushers can also be ordered with optional 6-32 or M4 threaded tips and/or body. Finally, the PZL pushers are available in a vacuum compatible version. All options, except the connector, must be specified when ordering because they cannot be retrofitted.

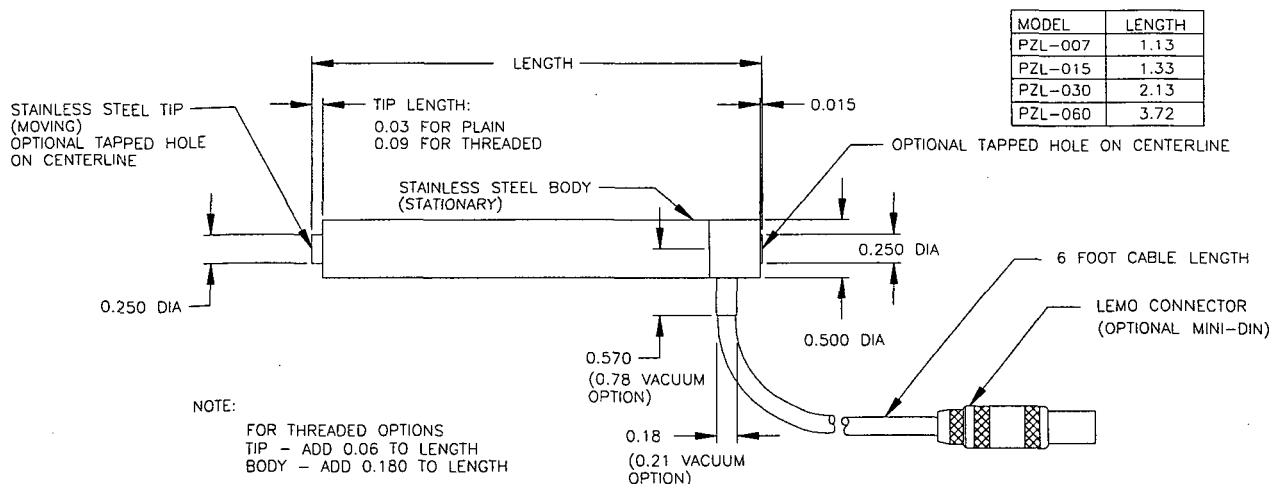

Figure 4.2. PZL Outline Dimensions

**PZS: (Figures 4.3 through 4.6)**

Burleigh's PZS Microstages have metal flexure joints machined in a special high strength body (aluminum or steel) which amplify the motion of the internal PZT element. These flexure stages are compact and rugged with low pitch and yaw errors. They can be mounted in X, X-Y, and X-Y-Z configurations. The PZS Microstages offer the same options for connector and cable interfaces and vacuum compatibility as the PZL pushers.

The 'HS' version of the PZS-100 (the PZS-100HS) has an extra damping plate in the front of the stage. The damper reduces the overshoot and ringing of the stage motion when high speed positioning capability is needed. The PZS-100HS comes standard with a 3 pin circular mini-DIN connector that mates with the PZ-100 Step Driver Electronics.

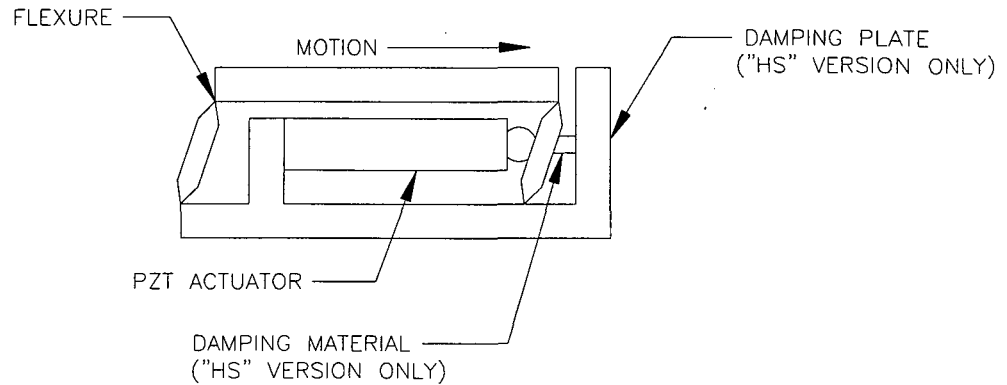

Figure 4.3. Schematic Drawing Of The PZS Microstage Design

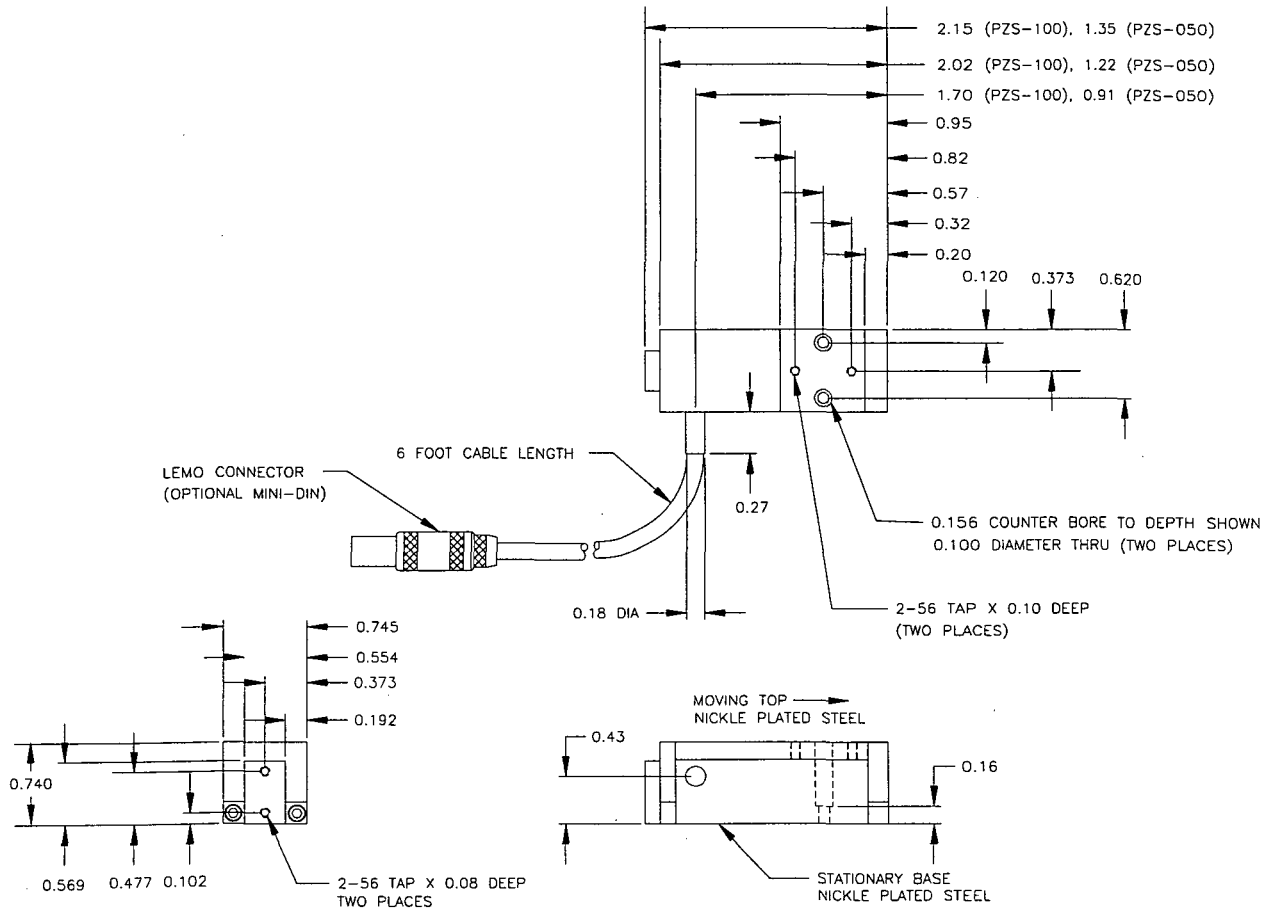

Figure 4.4. PZS-050 and PZS-100 Outline Dimensions



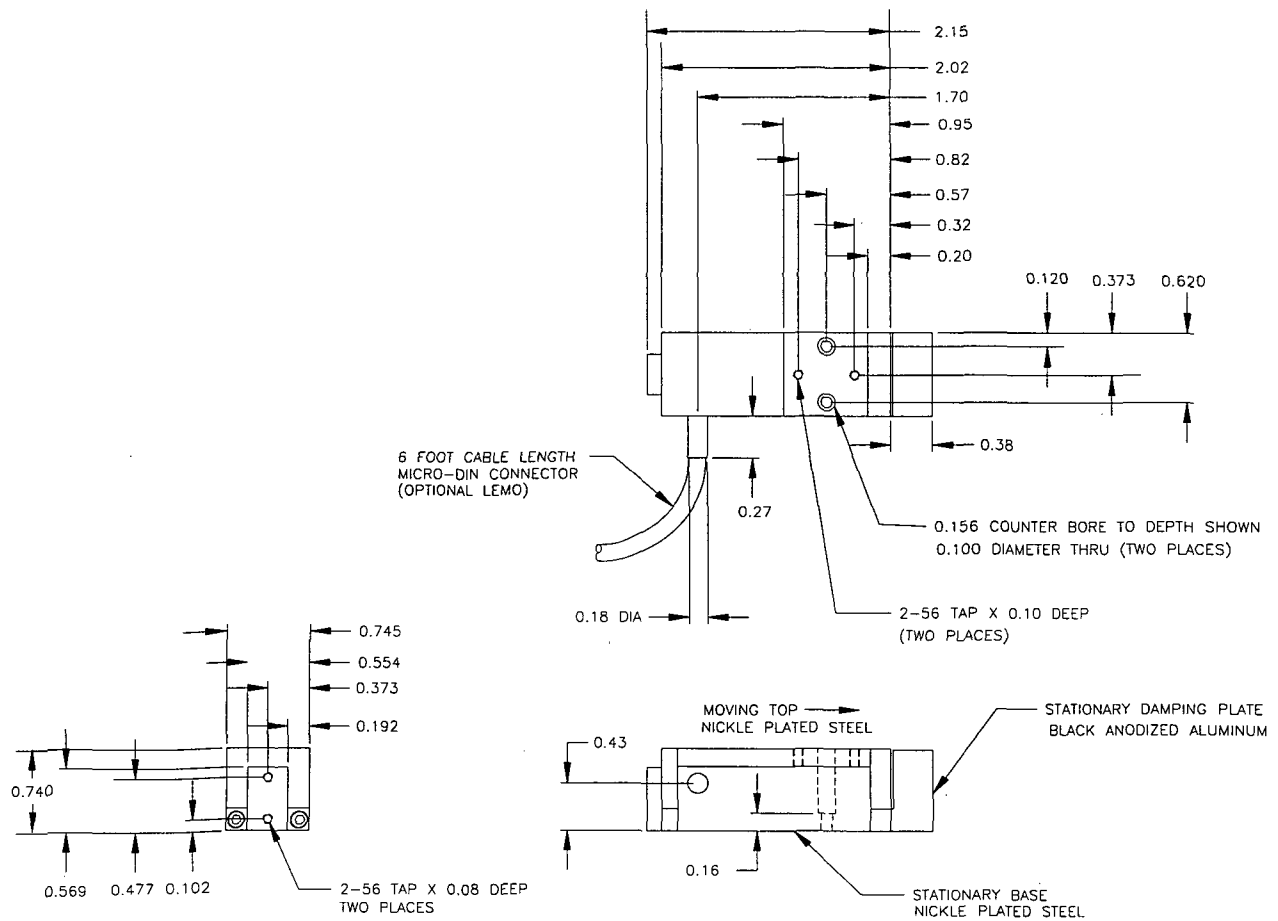

Figure 4.5. PZS-100HS Outline Dimensions

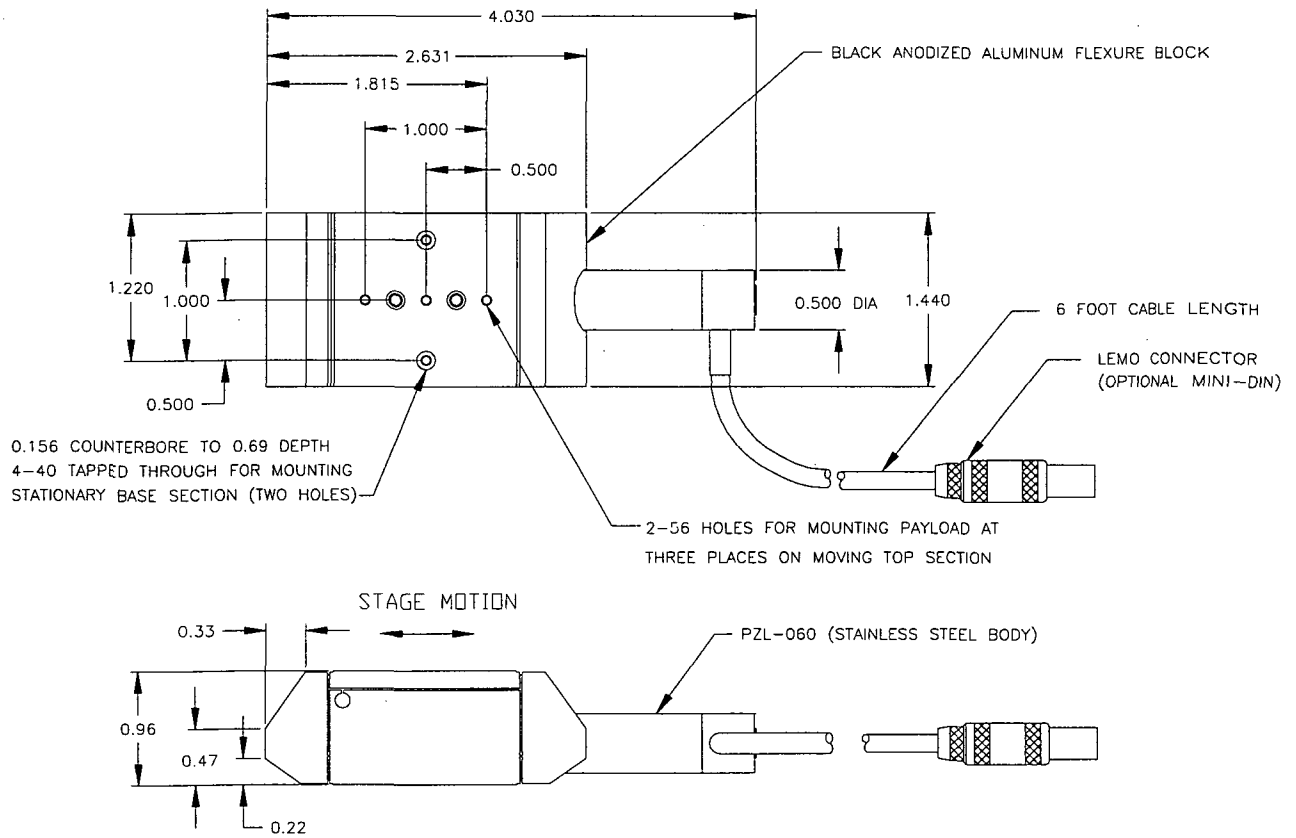

Figure 4.6. PZS-200 Outline Dimensions

## 4.2 Electronics

There are several Low Voltage Amplifiers or Drivers designed to suit individual micropositioning applications. The PZ-350 is a high frequency, three channel DC amplifier. It controls from one to three devices simultaneously and output voltages can be set manually with the front panel bias control or remotely with an analog input signal. The PZ-150 is a single channel high frequency amplifier. In operation the PZ-150 and PZ-350 are identical. The PZ-300 is a low current three channel amplifier for operation at DC or low drive frequencies. Each of these Amplifier/Drivers is comes with a front panel output voltage meter.

The PZ-100 is a microprocessor controlled single-axis Step Driver with high frequency response. The PZ-100 can be controlled from:

- Its keyboard,
- A personal computer via an RS-232 interface,
- An analog input/output connector,
- A remote handset.

**CAUTION: Do not attempt to drive Burleigh Low Voltage Piezoelectric Actuators with Burleigh High Voltage Drivers or other drivers that exceed the 150 volt specification. The piezoelectric elements can be permanently damaged. If you have questions, please consult Burleigh's Customer Service Department or your local representative.**

Refer to the PZ-100, PZ-150, PZ-300 or PZ-350 operating manuals for further information.

Refer to Section 5.3 for information on using Burleigh Low Voltage Piezoelectric Actuators with other electronics.



## 5. OPERATION

### 5.1 Mounting

To achieve precise and repeatable positioning on the submicron scale, you must pay careful attention to the mounting of your PZT actuator.

Mounting considerations:

- Minimize compliance in the mounting system.
  - \* Make sure that the mounting surfaces are flat and free of dust or debris.
  - \* Make sure the mounting surfaces mate evenly.
  - \* If an adhesive is used:
    - minimize the thickness of the adhesive layer
    - use a rigid adhesive like hard epoxy.
- Keep the PZT under compression.
- Keep forces on the actuator centered and parallel to the axis of motion.

#### **PZO:**

Burleigh's PZO Pushers are designed for mounting to their endcaps. The stainless steel housing is a thin walled tube (.010" thick) which cannot support compression forces. The PZO endcaps are ferromagnetic stainless steel and can be mounted magnetically, bonded with a suitable adhesive, or simply compressively loading against their mating surfaces. As an option, the moving endcap can have a countersink added to provide a kinematic interface for mating to a spherical part.

#### **CAUTION**

**The PZO can support only pure compressive loading. The actuator will be damaged if the endcaps are loaded with tensile (pulling), lateral, or twisting forces. If a load is mounted offset from the PZO centerline, lateral or twisting forces may be created.**

#### **PZL:**

Burleigh's PZL Pushers are easy to mount in a wide variety of systems. The rigid stainless steel housing allows clamping anywhere along the 0.500" diameter. Mounting can be done with a split ring clamp or with a close fitting ring using a nylon set screw tightened against the housing. PZL Pushers can also be mounted using the optional 6-32 or M4 threaded tips and/or bodies ( housings). Refer to Section 8-2 for information on the mounting adapters available.

The PZL can exert up to 0.8 Kg of tensile force. If a larger tensile force is exerted on the tip, the PZL will not function correctly, but will not be permanently damaged. The PZL design allows the tip to tilt without damaging the internal PZT element by allowing for small misalignments between the ceramic and the applied load.

**PZS:**

Burleigh's PZS Microstages can be mounted in a variety of configurations using their flat mounting surfaces. All models have moving top surfaces with 2-56 tapped holes and stationary bases with counterbored clearance holes for 2-56 screws. The mating surfaces must also be flat to less than 0.001 inches. See Section 4.0 for the specific mechanical details of your stage. All stages have symmetric hole patterns that allow direct X-Y stacked mounting.

**CAUTION**

**Make sure the mounting screws you use are not too long and do not interfere with the stage motion.**

The PZS can exert a tensile force of approximately 0.8 Kg. If a larger pull force is exerted on the tip, the PZS will not function correctly, but will not be permanently damaged. These rugged flexures can accommodate significant lateral and twisting forces.

**5.2 Electrical Connections****WIRING CHART**

Function	PZO color	PZL/PZS color pin #
+ V	red	red 1
return	black	white 2
	--	green 3
	--	black 4

See Section 8.1 for wiring for the Vacuum option.

**PZO:**

To use the PZO Pusher with Burleigh amplifier/drivers a mating connector is required. Refer to the above wiring chart. This connector is available from Burleigh upon request.

LEMO Part Number                      FFA.OS.304.CLAC 32

Burleigh Part Number                50186-0

**PZL/PZS:**

The PZL Pusher and PZS Microstage connect directly to Burleigh's PZ-150, PZ-300, and PZ-350 low voltage amplifier/drivers via their rear panel connector. If you use other electronics, refer to the wiring chart above. The mating connectors for the above standard LEMO are:

<u>STYLE</u>	<u>LEMO Part Number</u>	<u>Burleigh Part Number</u>
Cable Mounted	PCA0S304CLLC32	50224-0
Panel Mounted	ERA0S304CLL	50223-0

The PZS-100HS standard connector is a 3 pin Mini-DIN that mates with the PZ-100 Step Driver. If you use the PZS-100HS with other electronics please refer to the following pin diagram.

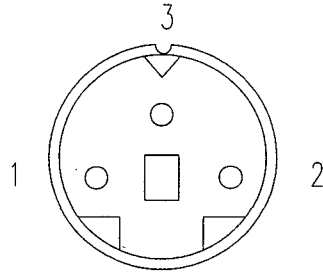

- 1 - High Voltage
- 2 - Return
- 3 - Ground

3-pin mini DIN male connector

### 5.3 User Supplied Electronics

This section describes the electronic amplifier performance required to drive Burleigh's Low Voltage Piezoelectric Actuators. Note that a reverse bias of negative 20 volts can be applied to these actuators which causes the PZT material to contract. A negative bias greater than negative 20 volts will repole the PZT element and cause the ceramic to start expanding again.

See Section 5.2 for information on electrical connections.

#### User Wiring specifications:

Voltage (V)	rated to 300
current (ma)	rated to 500

#### User Amplifier/Driver Specifications:

Voltage	-20 volts to +150 volts
Current	Less than 800 milliamps peak AC into a capacitive load (1,2)
Slew rate	Less than 0.5 Volts/ $\mu$ sec (2)

- (1) Higher device reliability will be obtained by limiting maximum driver current (see Section 5.5 below)
- (2) Higher current levels or slew rates may lead to failure of the internal piezoelectric elements

For AC applications, the current required to drive a PZT at a particular voltage and frequency is given by the following expression:

$$I_{rms} = 2 \times \pi \times F \times C \times V_{rms}$$

Where

$I_{rms}$	= required current in root mean squared amps
F	= drive frequency in Hertz
C	= PZT capacitance in Farads
$V_{rms}$	= root mean squared drive voltage



## 5.4 Performance

### IMPORTANT:

To achieve optimum repeatability, you should repole your Low Voltage PZT Actuator if these conditions have occurred:

- Your actuator has experienced temperatures greater than 60°C since its last use.
- Your actuator has not been used in more than 24 hours.

Poling procedure:

- Apply 150 volts to the actuator for 30 seconds.
- Return voltage to zero for 1 minute.

Effective use of PZT actuators for micropositioning requires an understanding of their motion properties. Burleigh's PZT actuators provide the ultimate in precision positioning when properly used. The inherent motion properties of all PZT materials include hysteresis, non-linearity, creep and step response. Figures 5.1 through 5.5 show the typical performance for Burleigh's Low Voltage PZT Actuator. See Section 7.0 for your specific actuator specifications.

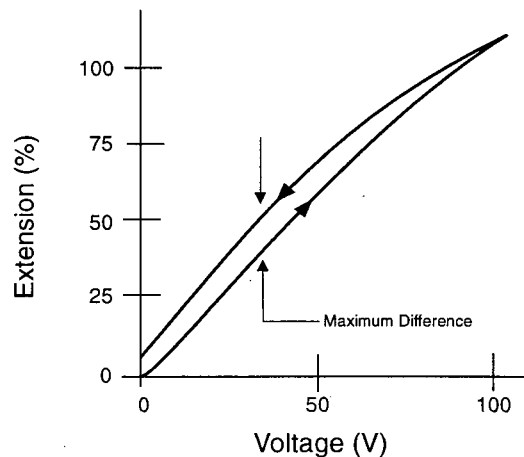

Figure 5.1. Typical Hysteresis Curve

**Hysteresis:** To minimize hysteresis, you should approach the desired voltage and position from the same direction. This insures that the actuator is always operating on the same part of the hysteresis curve.

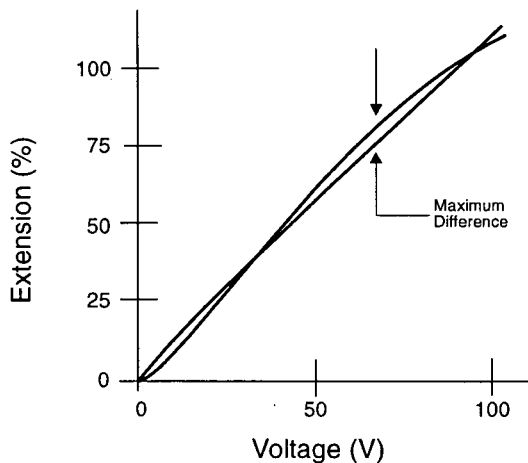

Figure 5.2. Typical Linearity Curve

**Non-linearity:** To achieve the best linearity, operate only on the lower (increasing voltage) section of the extension versus voltage curve.

**Creep:** The amount of creep depends on the direction and magnitude of voltage change. The magnitude is expressed as a percentage of the primary movement and these values are listed below. Creep time is the time for the rate of change in extension to drop below 1% of the full extension per minute.

	Increasing Voltage		Decreasing Voltage	
	Creep (%)	Creep Time (Sec)	Creep (%)	Creep Time (Sec)
PZO	2-5	20-30	6-10	40-70
PZL	1-2	10-20	7-8	60-80
PZS	3-4	20-40	4-5	50-70

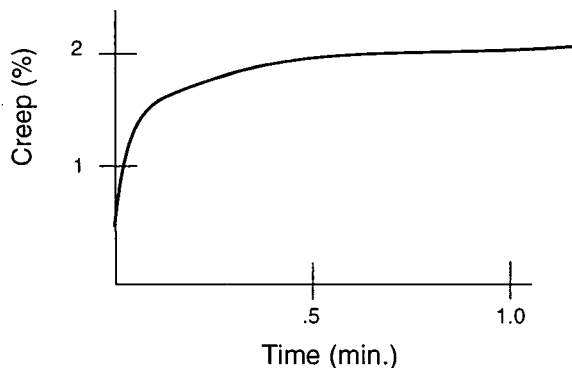

Figure 5.3. Typical Creep Curve

**Step response:** The typical step response for a PZO or PZL Pusher, driven by a PZ-150 Amplifier/Driver, is shown below. Figure 5.4 is the response with a 10 KHz amplifier bandwidth. A smoother and slower step function response is achieved by setting the PZ-150 Amplifier to 1 KHz bandwidth as shown in Figure 5.5.

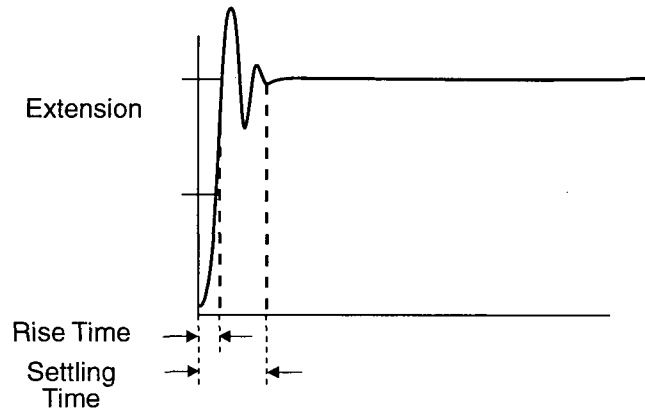

Figure 5.4. Typical Step Response - 10 KHz Bandwidth

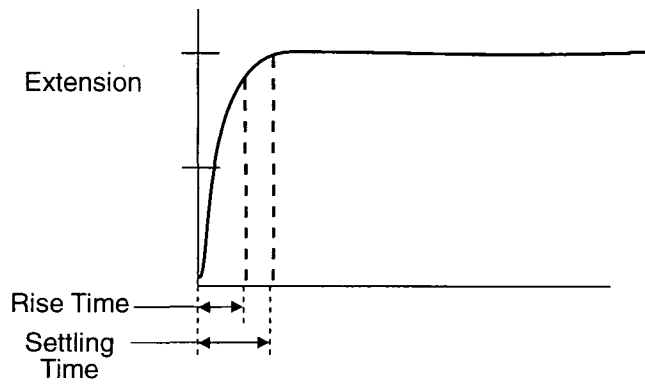

Figure 5.5. Typical Step Response - 1 KHz Bandwidth

## 5.5 Reliability

Burleigh's low voltage PZT actuators are sensitive to humidity. This sensitivity is higher at elevated temperatures and when large static voltages are applied. Burleigh has designed the actuator packaging to minimize this sensitivity, however, you should follow these guidelines to maximize the reliability of your device:

- Storage** When your actuator is not in use, store it in a dry environment such as a desiccator or other container containing a desiccant.
- Humidity** Avoid exposure to humidity greater than 50% during operation and storage.
- Voltage** Do not drive the actuator with large static (near 150 V) voltages for extended periods of time.
- Current** Use an amplifier/driver with the lowest output current (highest output impedance) needed for your application.
- Temperature** Avoid exposure to temperatures greater than 45°C during operation and storage.

**6. SERVICE**

There is no user service that can be done to Burleigh Low Voltage Piezoelectric Actuators. When any problems or questions arise, please contact the Burleigh Customer Service Department at:

Burleigh Instruments, Inc.  
Burleigh Park  
Fishers, New York 14453  
Tel. (716)924-9355  
Fax. (716)924-9072

Or contact your local representative.

**CAUTION** Do not turn or adjust any housing screws or disassemble any Burleigh Low Voltage Piezoelectric Actuators, this can affect device performance, may expose you to dangerous voltages and will void the warranty.

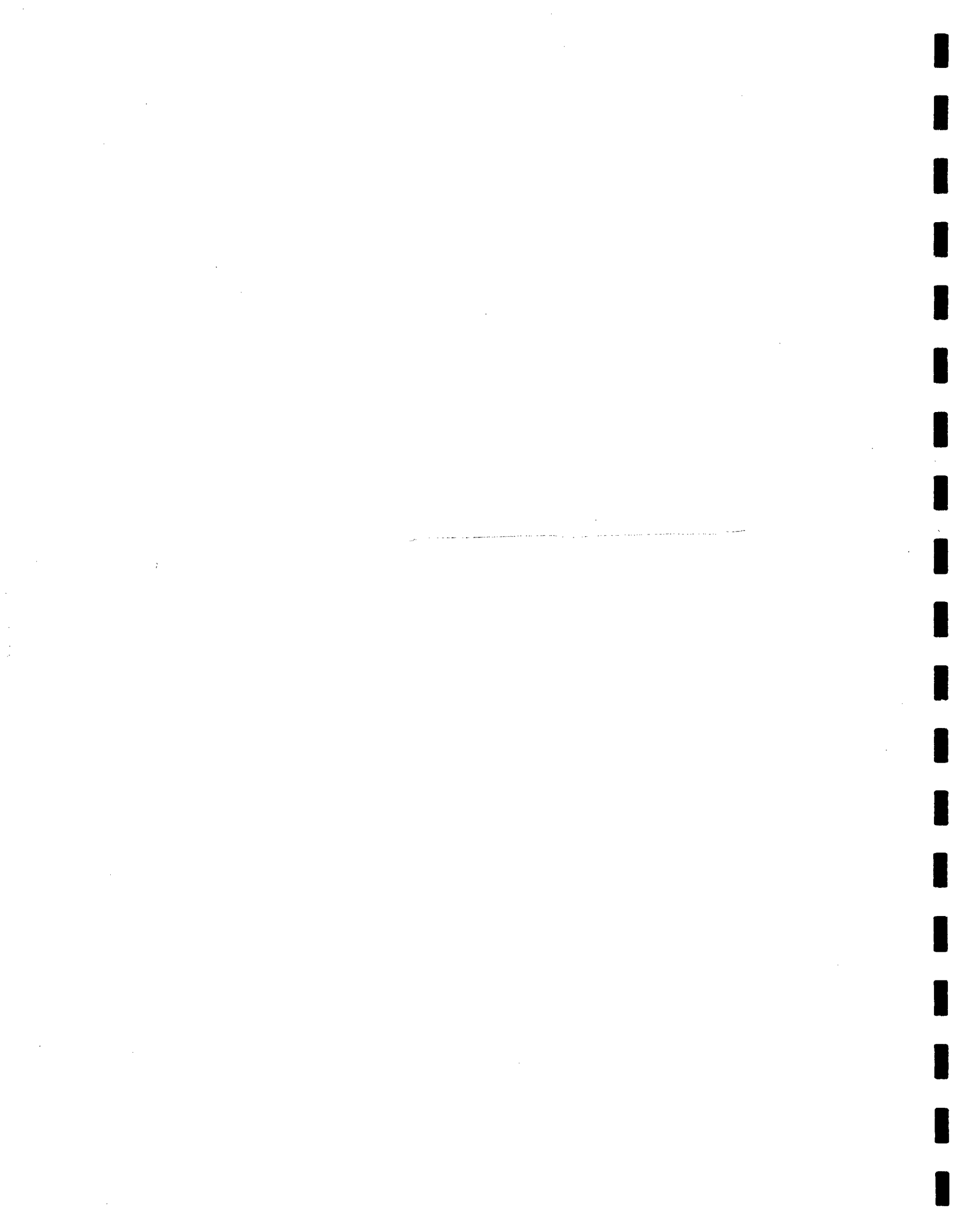

## 7. SPECIFICATIONS

### 7.1 PZO Pushers

Parameter	PZO Model Number		
	007	015	030
Motion for 0-150V (Micrometers)	7	15	30
Maximum Voltage (Volts)	150	150	150
Non-Linearity (%)	4	4	4
Hysteresis (%)	15	15	15
Maximum Load (Kg)	25	25	20
Frequency Response (KHz)	6.0	4.5	3.5
Capacitance ( $\mu$ f)	0.2	0.4	0.8
Compliance (micrometers/Kg)	1.0	1.4	2.4
Stiffness (N/micrometer)	9.0	7.0	4.1
Maximum Operating Temp ( $^{\circ}$ C)	70	70	70

## 7.2 PZL Pushers

Parameter	PZL Model Numbers			
	007	015	030	060
Motion for 0-150 V (micrometers)	7	15	30	60
Maximum Voltage (Volts)	150	150	150	150
Non-Linearity (%)	5	4	4	4
Hysteresis (%)	16	15	15	15
Maximum Load (Kg)	60	55	60	60
Frequency Response (KHz)	4.5	3.5	1.4	0.6
Capacitance ( $\mu$ f)	0.4	0.8	1.6	3.1
Compliance (micrometers/Kg)	0.6	1.0	1.5	2.5
Stiffness (N/micrometer)	16.0	9.8	6.5	3.9
Maximum Operating Temp ( $^{\circ}$ C)	70	70	70	70



## 7.3 PZS Microstages

Parameter	PZS Model Numbers		
	050	100/100HS	200
Motion for 0-150 V (micrometers)	50	105	300
Maximum Voltage (Volts)	150	150	150
Non-Linearity (%)	6	6	6
Hysteresis (%)	20	20	20
Maximum Load (Kg)	2.5	2.5	2.5
Frequency Response (KHz)	0.1	0.1	0.1
Capacitance ( $\mu$ f)	0.4	0.8	3.1
Compliance (micrometers/Kg)	25	33	75
Stiffness (N/micrometer)	0.4	0.3	0.13
Maximum Operating Temp ( $^{\circ}$ C)	70	70	70
Resonant Frequency No Load (Hertz)	--	420	400
Resonant Frequency 50 g Load (Hertz)	--	--	210

**NOTE:** The Frequency Response of the PZO-007, PZO-015, PZO-030, PZL-007, PZL-015, PZS-050, PZS-100 and PZS-200 are limited by mechanical resonances. The Frequency Response of the PZL-030, PZL-060 are limited by the output current of the PZ-150.



## 8. OPTIONS

### 8.1 Vacuum Operation (PZL-V, PZS-V)

PZL and PZS Low Voltage Piezoelectric Devices can be manufactured for vacuum operation. These devices are routinely used in vacuum in the range of  $10^{-6}$  to  $10^{-7}$  Torr. Important features are:

- Teflon cables.
- Special cleaning in Freon to remove residual contaminants.
- All cavities vented to prevent trapping air.

**NOTE:** Each device is supplied with an attached 6 foot Teflon cable with flying leads on the end to attach to a user supplied feedthrough. Additionally, a 6 foot adapter cable is supplied; one end has flying leads to attach to the user feedthrough, the other end terminates in a LEMO connector for use with a Burleigh Low Voltage Amplifier/Driver.

**NOTE:** The 6-32 and M4 mounting holes on the PZL tip and body are not vented. Vented screws must be used.

Heat is generated in PZT elements when the applied voltage changes and current flows. Under AC operating conditions-- this heat generation can limit the duty cycle. If you are operating at high frequencies and amplitudes for long periods of time you must monitor the temperature of you actuator. The actuator temperature must never exceed 70°C.

During initial operation in vacuum, self heating may cause some excess degassing which will result in a higher initial out-gassing rate; the actuator will return to the typical out-gassing rates listed below. The ultimate pressure obtainable depends on the pumping rate and background out-gassing rate of the your vacuum system.

**CAUTION:** The amplifier/driver must be turned off when pumping through the corona region (0.001 to 100 Torr). Failure to turn the amplifier/driver off may result in permanent damage to the PZT actuator, cables or amplifier/driver. Burleigh strongly recommends that vacuum/power interlocks be installed to prevent this type of damage.

**Typical performance:**

Within the limitations of excess heat generation described above, all positioning specifications are identical for the vacuum and non-vacuum PZL/PZS devices.

**vacuum range**  $10^{-6}$  to  $10^{-7}$

**bake-out temperature** 70°C (maximum)

**out-gassing rate**  $\leq 1 \times 10^{-6}$  Torr-Liter/second  
(typical for all models)

**Feedthrough requirements**

**voltage** rated to 300 V

**current** rated to 500 ma

**Wiring diagram**

LEMO Pinout	Vacuum Cable	Adapter Cable	PZL-V	PZS-V
1	red	red	+ V	+ V
2	white	white	return	return
3	green	green	N/C	N/C
4	black	black	N/C	N/C
case	shield	drain wire	housing	housing

### 8.2 Adapter

#### PZL-A

This 15 mm square adapter block allows the PZL to be mounted inside a square cavity or slot. It attaches along the length of the PZL housing with set screws. For a more rigid mount, it can also be permanently attached to the PZL with Loctite or other adhesive. The PZL-A will fit on any PZL. However, for a PZL-007, the PZL tip will not extend past the end of the PZL-A body.

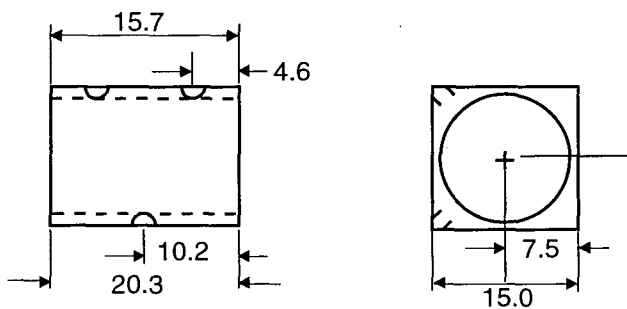

Figure 8.1. PZL-A Outline Dimensions



**9. WARRANTY**

Burleigh Low Voltage Piezoelectric Actuators, when used according to the operating specifications described in this manual, are warranted against defects in material and workmanship for a period of one year after date of delivery. During the warranty period, Burleigh will repair or, at its option, replace parts which prove to be defective when the device is returned prepaid to Burleigh Instruments, Inc. The warranty does not apply if the device has been damaged by accident, misuse, or as a result of modification by persons other than Burleigh personnel.

You must call Burleigh or your local representative for a Return Authorization Number (RA#) before returning any product. This will insure the prompt handling of the repair.

The liability of Burleigh (except as to title) arising out of supplying of said product, or its use, whether under the foregoing warranty, a claim of negligence, or otherwise, shall not in any case exceed the cost of correcting defects in the product as herein provided. Upon expiration of the warranty period specified herein, all liability shall terminate. The foregoing shall constitute the sole remedy of the buyer. In no event shall the seller be liable for consequential or special damages.

**burleigh**

Burleigh Instruments, Inc.  
Burleigh Park  
P.O. Box E  
Fishers, NY 14453-0755  
Tel. (716) 924-9355  
Fax. (716) 924-9072

PZL/PZO/PZS  
51518-M-00