



Artisan Technology Group is your source for quality new and certified-used/pre-owned equipment

- FAST SHIPPING AND DELIVERY
- TENS OF THOUSANDS OF IN-STOCK ITEMS
- EQUIPMENT DEMOS
- HUNDREDS OF MANUFACTURERS SUPPORTED
- LEASING/MONTHLY RENTALS
- ITAR CERTIFIED SECURE ASSET SOLUTIONS

SERVICE CENTER REPAIRS

Experienced engineers and technicians on staff at our full-service, in-house repair center

*InstraView*SM REMOTE INSPECTION

Remotely inspect equipment before purchasing with our interactive website at www.instraview.com ↗

WE BUY USED EQUIPMENT

Sell your excess, underutilized, and idle used equipment. We also offer credit for buy-backs and trade-ins. www.artisanng.com/WeBuyEquipment ↗

LOOKING FOR MORE INFORMATION?

Visit us on the web at www.artisanng.com ↗ for more information on price quotations, drivers, technical specifications, manuals, and documentation

Contact us: (888) 88-SOURCE | sales@artisanng.com | www.artisanng.com

WA-2500 WAVEMETER_{JR}[®] **OPERATING MANUAL**

Operating Manual (Rev. E)
04659-M-00

Copyright © Burleigh Instruments, Inc. 1997
All Rights Reserved

Wavemeter is a registered trademark of Burleigh Instruments Inc.

burleigh

Burleigh Instruments, Inc.
Burleigh Park
P.O. Box E
Fishers, NY 14453-0755
Tel: (716) 924-9355
Fax: (716) 924-9072

TABLE OF CONTENTS

1.	INTRODUCTION.....	1-1
1.1	APPLICATIONS	1-1
1.2	THEORY OF OPERATION.....	1-1
2.	INITIAL INSPECTION.....	2-1
2.1	VISUAL INSPECTION	2-1
2.2	OPERATIONAL INSPECTION.....	2-1
3.	OPERATING INSTRUCTIONS	3-1
3.1	INITIAL SET UP	3-1
3.2	BEAM RECEIVER MOUNTING	3-1
3.3	BEAM RECEIVER ALIGNMENT.....	3-2
3.4	BAR-GRAPH INTENSITY METER	3-4
3.5	UNITS SELECTION.....	3-4
3.6	AVERAGE MODE	3-4
3.7	CALIBRATION FUNCTION.....	3-5
3.8	MONITOR, TRIGGER AND WINDOW OUTPUTS	3-5
3.9	AUTO-RESOLUTION FEATURE.....	3-6
3.10	RS-232 INTERFACE.....	3-8
3.11	INTERFEROMETER ALIGNMENT.....	3-9
3.12	DETECTOR INTERCHANGE	3-13
3.13	100 VAC Operation	3-14
3.14	Operation with Mode-locked and Other Low Coherence Lasers	3-15
4.	MAINTENANCE AND SERVICE	4-1
4.1	Error Messages.....	4-1
4.2	TROUBLESHOOTING.....	4-2

4.3	Changing the Line Voltage	4-3
4.4	Changing the Fuse	4-3
5.	ACCESSORIES	5-1
5.1	Recommended Mounts	5-1
5.2	Optional Components	5-2
6.	SPECIFICATIONS	6-1
7.	WARRANTY	7-1
	APPENDIX A. SAMPLE PROGRAM	A-1

1. INTRODUCTION

1.1 APPLICATIONS

The WA-2500 Wavemeter_{jr} is an instrument for wavelength measurement of CW laser sources that combines accuracy with ease of use. The accuracy is ± 1 part in 10,000 over the full wavelength range.

The primary application for Model WA-2500 is measurement of the wavelength or the frequency of tunable lasers that operate from 400 to 1800 nanometers, particularly dye lasers, Ti:Sapphire lasers and diode lasers. Two detectors are provided to cover this range with high sensitivity. The VIS detector is used for lasers operating from 400 to 1100 nanometers, and the IR detector for lasers that operate from 600 to 1800 nanometers.

1.2 THEORY OF OPERATION

Laser light enters the Wavemeter_{jr} through a fiber optic cable. Lasers that emit a collimated beam can be easily coupled into the fiber by a beam receiver consisting of an Input Beam Coupler (BC-1) and an FC connector terminated 3 meter patch cord (PC-F). The beam receiver can be mounted in a simple optical mount that provides rotation about 2 axes. The efficiency of coupling laser light into the fiber is optimized by small angular adjustments of the beam receiver in θ and ϕ . The opposite end of the fiber optic cable connects at the rear panel of the Wavemeter_{jr} and injects the light into the chassis.

Inside the chassis of the Wavemeter_{jr} is a compact scanning Michelson interferometer. The incoming laser beam is split into two paths, with one path length varied by a scan mechanism. The two paths are recombined, producing interference fringes that are detected by a photodiode. Simultaneously, the displacement of the scan mechanism is measured by a high resolution Moiré gauge. The microprocessor computes the correct wavelength or frequency from these two signals, and transmits this data to the front panel display and RS-232 port. The units of measurement are selected by a push button on the front panel.

The Moiré gauge attached to the scan mechanism of the Michelson interferometer must be calibrated against a red HeNe laser. This is accomplished by introducing a HeNe laser beam into the beam receiver and depressing the CALIBRATION button on the front panel. The calibration value is stored in non-volatile memory that is unaffected by power interruption.

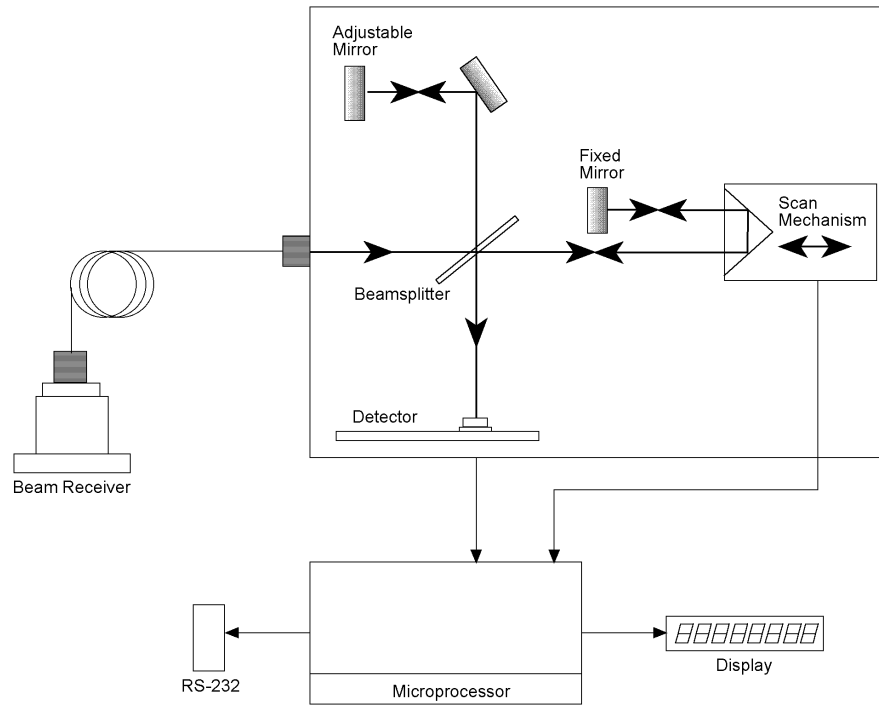

Figure 1.1. Wavemeter_{jr} Layout.

Two modes exist for the measurement cycle. In the standard mode, the measurement is performed and displayed every 200 milliseconds. When the AVERAGE button is depressed, the data is accumulated for 10 sequential measurements and the display is updated with the average value every 2 seconds. The AVERAGE mode is particularly useful for lasers that possess some frequency jitter.

The Wavemeter_{jr} upper front panel includes a six digit LED display and a bar-graph intensity meter. The intensity meter indicates the peak to peak intensity of the interferometer fringe signal, and can be used to facilitate alignment of the beam receiver with the input laser beam. A “LO SIG” or “HI SIG” message will also be flashed on the display when a low or high input intensity condition exists.

Three BNC coaxial connectors on the rear panel allow you to diagnose the operation of the instrument with an oscilloscope. These are labeled MONITOR, WINDOW, and TRIGGER. Together, they enable the user to observe the fringe signals from the Michelson interferometer in order to align the beam receiver, optimize the alignment of the interferometer’s adjustable mirror, and analyze the characteristics of the laser input.

The auto-resolution feature built into the Wavemeter_{jr} circuitry allows the instrument to measure the wavelength of lasers with linewidths as great as 3000 GHz, despite the associated low coherence length. The auto-resolution circuitry automatically adjusts the measurement range to be consistent with the coherence length, and the result is displayed with relevant precision.

2. INITIAL INSPECTION

2.1 VISUAL INSPECTION

The Wavemeter_{jr} has been packaged in a special carton designed to give maximum protection during shipment. If the outside of the shipping carton is damaged, notify your shipping department immediately. The shipping department may wish to notify the carrier at this point.

If the shipping carton is undamaged externally, the instrument can be removed from the carton. If any damage is evident visually or if any loose components can be heard when the instrument is inverted, notify your shipping department and Burleigh Instruments, Inc. It is advisable to save the special carton for future storage or transportation.

2.2 OPERATIONAL INSPECTION

The purpose of this section is to provide a brief functional check of the Wavemeter_{jr}. Please perform the following procedure upon receiving the instrument. Complete operating instructions and feature descriptions will be found in Section 3 of this manual.

NOTE: Before plugging in the instrument check that the 115/230 VAC switch on the rear panel is correctly set for the line voltage. Incorrect setting can cause permanent damage to the instrument. For 100 VAC operation set the 115/230 VAC switch to 115 VAC and refer to Section 3.13 for the correct internal transformer connections.

Place the Wavemeter_{jr} on a firm horizontal surface (optical bench or lab table). Attach the AC line cord. Turn on the power switch and listen for any unusual noises. When the power switch is turned on or off, you should hear an audible click caused by the solenoid lock that secures the interferometer scanning assembly when power is off.

With power on, two of the UNITS lights should illuminate and the numerical display should light all 8's and decimal points for one second followed by a count down beginning at 10. After a few seconds the countdown should be interrupted by a display that alternates between "LO SIG" and "_ _ _ _ _" until a laser input is introduced. If the countdown continues to zero, turn off the unit, wait 10 seconds, and try again. Consult the troubleshooting section of this manual if the countdown to zero operation persists.

To test the UNITS display, press the UNITS button on the lower front panel. Two lights should illuminate, and the UNITS display should change in sequence — nm/vac, cm⁻¹/vac, nm/air, cm⁻¹/air - each time you press the button.

Press the AVERAGE button. It should illuminate and remain locked in place until you press the button again.

Press the CALIBRATE button. The display should read "CAL" for approximately two seconds followed by the word "FAIL". This is correct, given that there is no calibration laser input.

Observe the two DETECTOR indicators on the rear panel. The VIS indicator illuminates when the detector is configured for visible wavelength (400-1100 nm) operation. The IR indicator illuminates when the detector is configured for a wavelength range from 600 to 1800 nm.

Once you have completed all of these checks successfully, refer to Section 3 of this manual for further operating instructions.

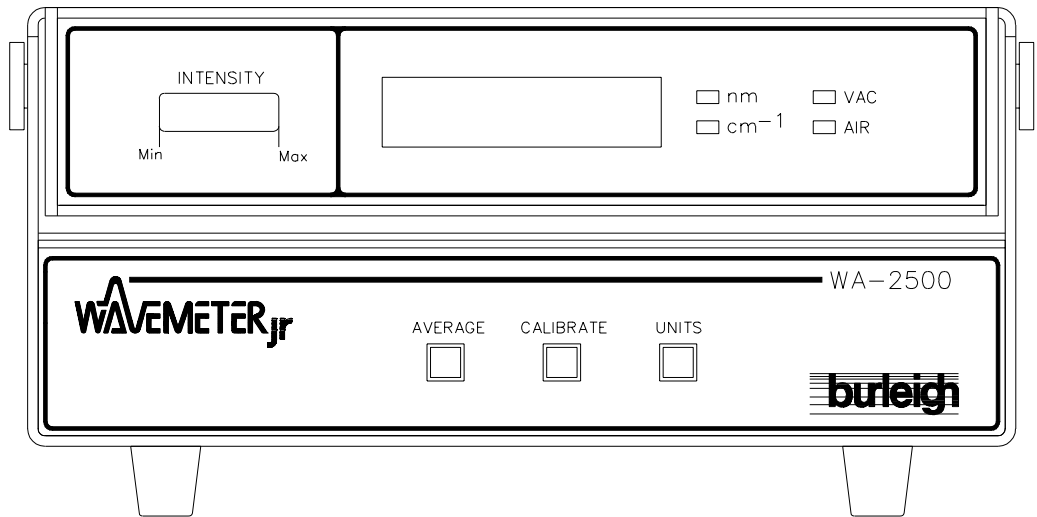

Figure 2.1. WA-2500 Front Panel.

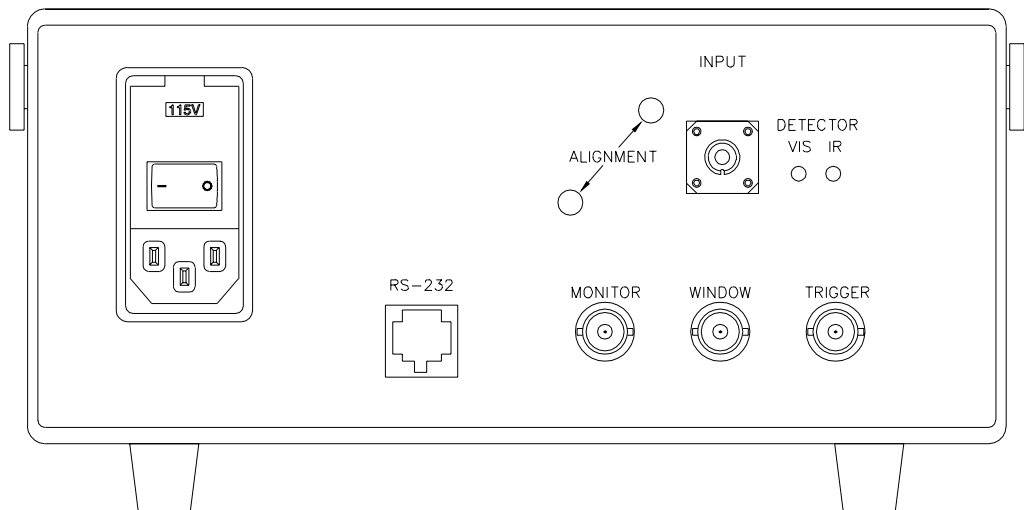

Figure 2.2. WA-2500 Rear Panel.

3. OPERATING INSTRUCTIONS

3.1 INITIAL SET UP

Position the Wavemeter_{jr} on a firm horizontal surface. It is important that this surface be horizontal and stable to ensure proper operation of the internal interferometer scanning mechanism. The upper front panel is swivel mounted to accommodate a wide range of viewing angles. Tilt the upper front panel to a comfortable viewing angle.

NOTE: Check that the 115/230 VAC on the rear panel is correctly set and attach the AC line cord. If the initial operational check has not been performed, refer to Section 2.2 of this manual. For 100 VAC operation, refer to Section 3.13.

3.2 BEAM RECEIVER MOUNTING

The optional beam receiver accessory consists of an optical coupling head (BC-1) attached to a 3 meter FC connector terminated patch cord (PC-F) which provides the input beam for the instrument.

CAUTION: The fiber optic cable and internal components of the coupling head are made of glass and must be handled with care. Do not drop, bend sharply, stretch, or otherwise stress the cable particularly in the vicinity of the connector. Permanent damage to the cable can result. Do not drop the coupling head.

Optical power incident on the beam receiver should not exceed 100 milliwatts over the entire operating range of 400 to 1800 nm. For beams smaller than the input aperture of 2.5 mm, the maximum allowable power must be adjusted downward to avoid exceeding safe power densities. Optical powers in excess of these limits may cause irreparable damage to the assembly.

To install the beam receiver, first remove the dust covers from the fiber optic input on the rear panel of the Wavemeter_{jr}, the BC-1 optical coupling head and both ends of the FC connector terminated patch cord. Store these dust covers for future use. Connect the fiber optic cable to the FC connector on the rear panel of the instrument and to the BC-1 optical coupling head. There is a “keyed” position for the connector. Rotate this into position before tightening the knurled lock ring.

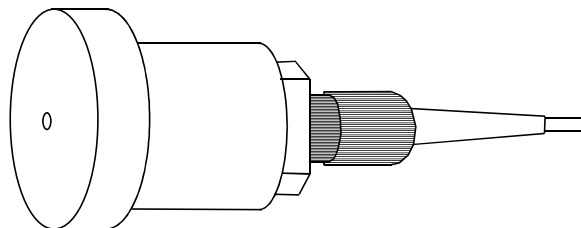

Figure 3.1. Beam Receiver.

NOTE: Handle this assembly with care. Avoid contact with exposed optical surfaces. Do not apply stress to the fiber optic cable. The knurled lock ring requires only modest torque to correctly secure the connector.

The beam receiver may be mounted in most θ , ϕ adjustable optical mounts designed for a 25.4 millimeter diameter optic. Several models of suitable mounts from a variety of manufacturers are listed in Section 5.1.

NOTE: The beam receiver is also available with a mounting diameter of 30 mm (BC-3). Consult your Burleigh representative for more information.

Optical mounts with X-Y as well as θ , ϕ adjustments may be convenient in some laboratory configurations. However, basic θ , ϕ adjustments are usually sufficient. When selecting a mount, please note that there must be a 'clearance hole' which is slightly larger than the coupling head's main body diameter (0.990"). If such a mount is unavailable, you can mount the coupling head facing in a direction opposite to that shown.

Install the beam receiver coupling head in the optical mount. You may have to separate the BC-1 coupling head from the fiber optic cable to insert it in some styles of optical mount. To detach the fiber optic connector, loosen the knurled lock ring. Handle the beam receiver assembly with care.

3.3 BEAM RECEIVER ALIGNMENT

The beam receiver head has a 25.4 mm diameter target disk with a 2.5 mm aperture. A lens centered behind the aperture efficiently couples a collimated laser beam into the optical fiber when the axis is properly aligned to the laser beam axis.

Alignment is simplified by two reflections from inside the beam receiver. Accurate alignment into the fiber can be achieved by centering these reflected spots about the incoming beam, as shown in Figure 3.2.

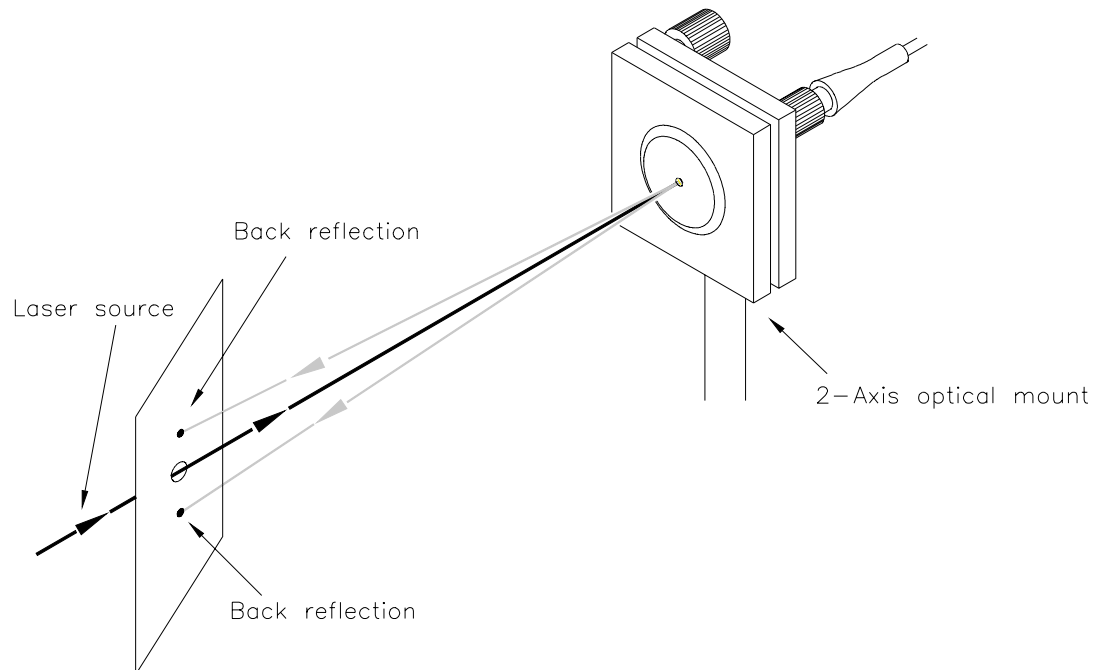

Figure 3.2. Beam Receiver Alignment.

The laser beam should be centered on the input aperture. This is typically accomplished with upstream optics, such as a beamsplitter, that directs a small portion of the laser beam toward the beam receiver. Adjust the face of the beam receiver to be orthogonal to the laser beam using the angular adjustments of the optical mount.

Two back reflections from inside the beam receiver should be visible near the laser output aperture. They can also be seen by placing a white card (with a hole in the center) in the beam as shown in Figure 3.2. Adjust the optical mount until the point halfway between the two spots is centered on the laser beam. There should now be enough light coupled into the fiber optic cable to maximize the throughput by observing the bar-graph intensity meter on the upper front panel.

The input intensity bar-graph meter should be illuminating a number of segments proportional to the amount of optical intensity incident on the beam receiver. Optimize the alignment to illuminate approximately 5 to 8 segments of the bar-graph meter.

If the LED display indicates “LO SIG”, verify that the laser power incident at the beam receiver exceeds the specified input power in a 2.5 mm collimated beam. If the intensity bar-graph meter is fully lit, slightly misalign the optical mount so that approximately 5 to 8 of the 10 segments of the bar-graph are on. At this point the Wavemeter_{jr} will display the wavelength or frequency of the laser.

If there is sufficient intensity in the incident laser beam, but insufficient intensity to observe the back reflections, try one of the following procedures:

WARNING: Although the FC connector emits an output beam with a wide divergence angle, optical power densities from a visible or non-visible laser viewed at any distance can still cause irreparable eye damage. Never look along or even close to the axis of the FC connector when laser light is present at either end of the assembly. Never look directly at the output of the FC connector receptacle at the back end of the coupling head when the FC cable is disconnected. Handle the beam receiver safely; laser light will transmit over great distances.

1. Remove the FC connector from the rear panel of the Wavemeter_{jr} and observe the transmitted intensity against a suitable viewing screen before reconnecting the fiber optic cable to the instrument.
2. Observe the actual fringe signal from the internal Michelson interferometer by connecting an oscilloscope to the MONITOR output on the Wavemeter_{jr} rear panel. The oscilloscope sweep should be synchronized with the scan of the interferometer using the TRIGGER output from the Wavemeter_{jr}. Utilizing the extra sensitivity of the oscilloscope, it is possible to detect very low intensity input signals as a starting point for optimizing the alignment of the beam receiver. Refer to Section 3.8 of this manual for a description of the oscilloscope pattern from the MONITOR output. If no fringe signal can be detected on the oscilloscope, refer to Section 3.11 for details regarding alignment of the Michelson interferometer.
3. If the initial alignment to an infrared laser is difficult due to the absence of infrared viewing equipment, the beam receiver can be aligned with a HeNe tracer beam that is set up to be collinear with the infrared beam. The co-linearity of the two beams can be established by a pair of apertures and a photodetector that is sensitive at the wavelength of the infrared laser. Once the Wavemeter_{jr} is aligned with the HeNe tracer beam, it should be possible

to observe a weak signal from the infrared beam on the bar-graph intensity meter or the MONITOR output.

3.4 BAR-GRAPH INTENSITY METER

The bar-graph intensity meter on the upper front panel of the Wavemeter_{jr} is a valuable aid for optimizing the input intensity to the instrument. It indicates the peak-to-peak amplitude of the fringe signal detected by the internal Michelson interferometer. The bar-graph intensity is sampled from the fringe signal (as observed from the MONITOR output) at the beginning of the TRIGGER period. If the Michelson interferometer is properly aligned this fringe signal and the bar-graph meter will increase and decrease with input laser intensity.

NOTE: **If the Michelson interferometer is out of alignment, no signal will be indicated on the bar-graph meter even when the input intensity is very high. In this case an “ALI Er” message will appear on the display to warn against introducing too much intensity. Never illuminate the beam coupler head with intensity above 100 milliwatts as described in Section 3.2.**

The bar-graph meter has a non-linear response. The sensitivity is greatest at low intensities for detecting weak input beams but becomes less sensitive for greater dynamic range as the intensity increases. It is factory set so that 1 or 2 segments are lit at the threshold where the Wavemeter_{jr} starts to read. Below this level the display will flash the message “LO SIG”. All segments are illuminated at approximately 10 times the threshold input power, and the display will flash the message “HI SIG” when the range of the bar-graph is exceeded. For optimal operation, the input intensity level should be adjusted to illuminate approximately 5 to 8 segments on the 10 segment bar-graph meter to allow for variations in the laser power.

3.5 UNITS SELECTION

You can select any one of four display units for the Wavemeter_{jr} readout. To change the display units selection, press the UNITS button on the lower front panel until the desired selection appears on the upper front panel.

VACUUM WAVELENGTH in nanometers (nm/vac)
VACUUM FREQUENCY in wavenumbers (cm⁻¹/vac)
AIR WAVELENGTH in nanometers (nm/air)
AIR FREQUENCY in wavenumbers (cm⁻¹/air)

The units selection is stored in non-volatile memory so that it is not changed when power to the Wavemeter_{jr} is interrupted.

3.6 AVERAGE MODE

The Wavemeter_{jr} normally completes and displays a new measurement every 200 milliseconds (5 times per second). In the Average Mode, 10 measurements are taken in succession and averaged to generate each new display value. The display updates approximately every 2 seconds.

To activate the Average Mode, press the AVERAGE button on the lower front panel. The button lights when it is in the “on” position. Press the button again to return to normal operation.

3.7 CALIBRATION FUNCTION

The scan of the Michelson interferometer inside the Wavemeter_{jr} must be calibrated against an external HeNe laser. This is done at the factory and the initial calibration constant is stored in non-volatile memory. The calibration can be checked at any time by measuring the wavelength of any red HeNe laser.

HeNe Vacuum Wavelength = 632.99 nanometers

If calibration is necessary, press the CALIBRATE button on the lower front panel while there is a red HeNe laser beam input. The upper front panel will display the message “CAL” for approximately 2 seconds during the calibration measurement and then return to display the correct HeNe wavelength or frequency, depending on the units selected.

If the CALIBRATE button is depressed without a red HeNe laser input, the Wavemeter_{jr} will display the message “CAL” followed by “FAIL” and return to the previously displayed data without altering the stored calibration constant. Consequently, the possibility of accidentally losing the calibration value is low. The only exception to this calibration protection feature involves the presence of laser light within approximately $\pm 0.5\%$ of the HeNe wavelength.

3.8 MONITOR, TRIGGER AND WINDOW OUTPUTS

Three BNC coaxial connectors on the rear panel allow you to check the Wavemeter_{jr} operation with an oscilloscope. They are designated as TRIGGER, WINDOW, and MONITOR. The MONITOR output is the detector signal generated by the laser interference fringes from the Michelson interferometer. This is an analog signal with a peak-to-peak value that represents the intensity of the interference fringes.

The TRIGGER output is a TTL signal that is high (+ 5 v) for that portion of the interferometer scan during which a measurement can be made. It initiates the measurement cycle and should be used to trigger the oscilloscope when observing the MONITOR and WINDOW signals. The TRIGGER interval is factory set to be approximately 30 milliseconds.

The WINDOW output is a TTL signal that is high (+ 5 v) for that portion of the interferometer scan during which the measurement is actually made. The WINDOW signal starts at the same time as the TRIGGER signal and terminates as soon as the fringe signal amplitude falls below an adequate level.

Examples of the MONITOR, TRIGGER and WINDOW signals for various types of laser inputs are shown in Figure 3.3. For highly monochromatic lasers depicted in the upper spectrum, the TRIGGER and WINDOW signals will be identical because there is no decrease in the fringe amplitude until the end of the scan. For lasers that are spectrally broad, including multi-line lasers, the measurement will be terminated as soon as the fringe envelope falls below 500 millivolts peak-to-peak.

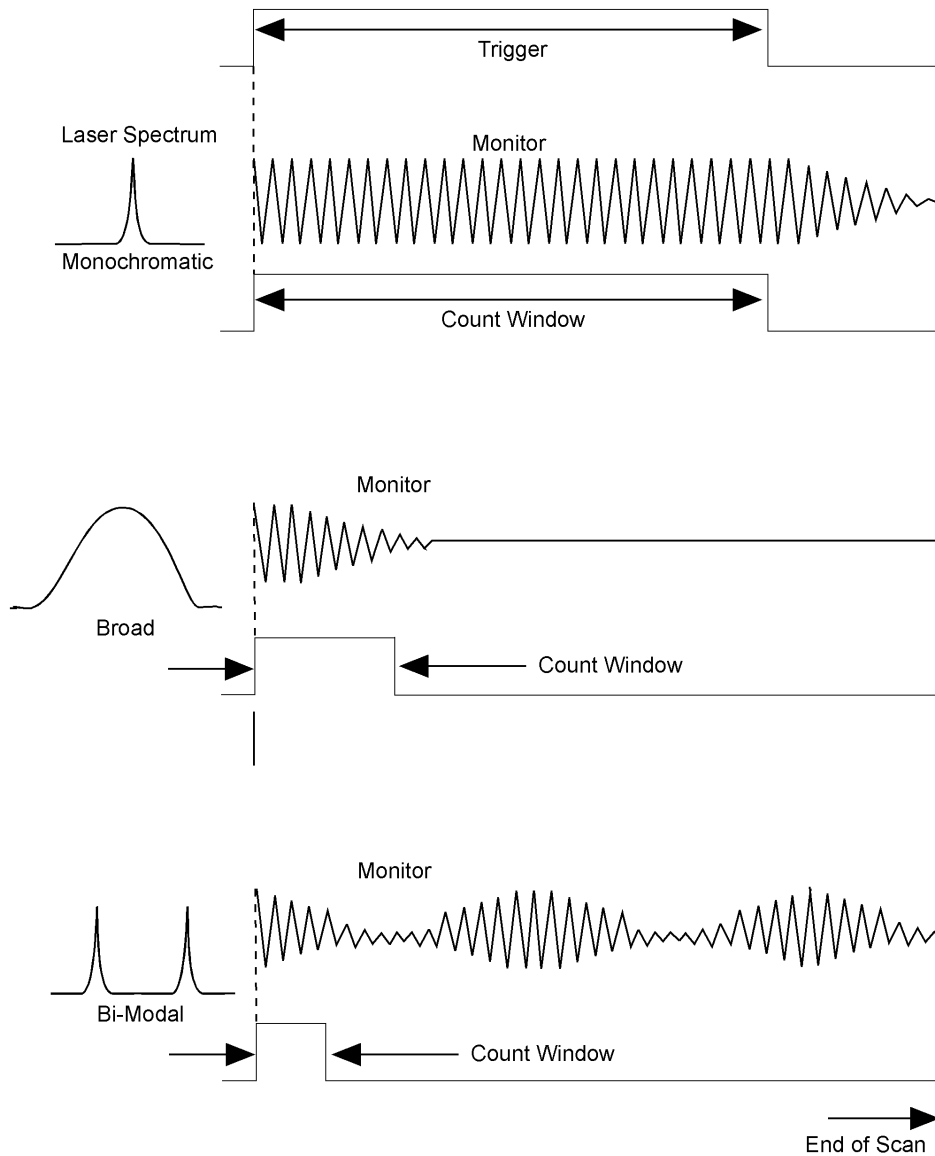

Figure 3.3. Monitor, Trigger and Window Outputs for Different Spectra.

3.9 AUTO-RESOLUTION FEATURE

The Wavemeter_{jr} displays the wavelength or frequency to the specified accuracy of ± 1 part in 10,000 for lasers with linewidths less than 150 GHz (5 cm^{-1}). Lasers with greater linewidths exhibit reduced coherence lengths, which in turn reduces the number of useful fringes generated in the Michelson interferometer.

The Auto-Resolution feature automatically adjusts the precision of the wavelength or frequency display for lasers with linewidths greater than 150 GHz. The length of the WINDOW defines the number of useful fringes actually counted by the Wavemeter_{jr}. The Auto-Resolution circuitry computes the appropriate readout based on the accuracy implicit in the number of fringes that can be counted. Insignificant digits are eliminated and replaced by a “_” character on the display.

For example, the wavelength 654.32 nm will be displayed as 654.3_ nm for a linewidth between 150 and 1500 GHz, while a display of 654. __ nm will result from a laser with a linewidth between 1500 and 3000 GHz. If the linewidth exceeds 3000 GHz, the display will present the message “COH Er” indicating that the coherence length is insufficient for wavelength measurement.

To establish the correspondence between linewidths in wavelength units and frequency units, use the graph in Figure 3.4 for the particular laser wavelength of interest. Interpolate for wavelengths in between those that are plotted. For example, a 654.32 nm dye laser with a wavelength linewidth of 0.5 nm has a frequency linewidth equal to 12 wavenumbers according to the graph and would be displayed with 4 digit resolution as 654.3_ nm.

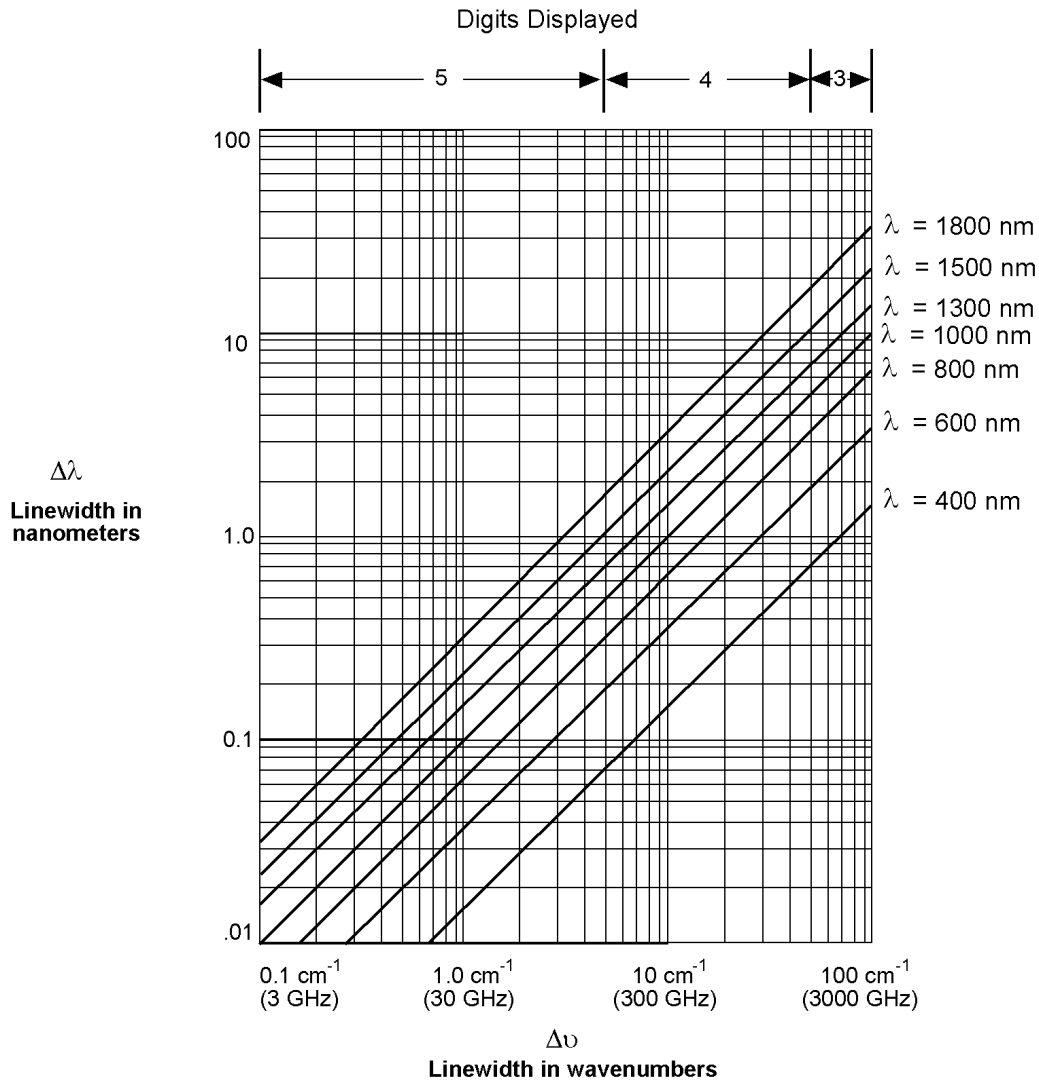

Figure 3.4. Auto-Resolution Conversion Chart.

3.10 RS-232 INTERFACE

The Wavemeter_{jr} features an RS-232 port (often referred to as a serial or asynchronous communications port) for connecting to peripherals such as printers or terminals. The RS-232 port can also be used to transfer data to a personal computer. Measurement values and error messages transmitted to the port comply with the RS-232-C Serial Communications EIA Standard.

Pin	Wire	Label	Description (O = Output, I = Input)
1	Brown	GRND	Protected Ground
2	Blue	NC	Not Used
3	Yellow	TXD	Transmit Data (O)
4	Green	DTR	Data Terminal Rdy (O)
5	Red	RXD	Receive Data (I)
6	Black	CTS	Clear to Send (I)
7	Orange	SGRND	Signal Ground
8	White	NC	Not Used

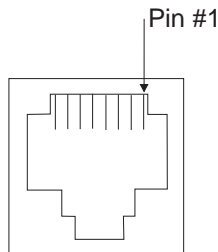

Figure 3.5. RS-232 Receptacle.

The Wavemeter_{jr} RS-232 output is configured as 2400 Baud, 8 data bits, 2 stop bits and no parity. Flow control is handled via software (XON/XOFF) or hardware (CTS/RTS) handshaking. The maximum line length is 22 characters followed by a carriage return/line feed (CR/LF) character pair indicating the end of each line of data.

If the user halts the data transmission for more than 10 lines of readings or 30 lines of error messages, the transmission buffer will clear itself and wait for a CTS or an XON before filling again. This is to prevent the transmission of old data in the event that the user indefinitely suspends data transmission. A “232 Er” message will appear periodically on the display warning of a data transmission problem. When transmission resumes, a “Transmission Break” message will be transmitted before new data appears, indicating there has been a gap in data transmission.

The WAVEMETER_{jr} is a “talk only” device that supports the Xon/Xoff handshake protocol. Data transmission can be halted (Xoff) by sending a “^S” character (13 Hexadecimal) to the “Receive Data” (RXD:pin#5) line. Data transmission can be restarted (Xon) by sending a “^Q” character (11 Hexadecimal) to RXD.

An alternative method to control data transmission is provided through the “Clear

To Send” (CTS:pin#6) line. The CTS line is pulled high (+12V) to produce a “true” by default, enabling data transmission in the absence of a user supplied signal to CTS. If the CTS line is made “false,” data transmission will cease until CTS is made “true” again.

If the data transmission is halted by the user for more than 10 lines of readings or 30 lines of error messages, the transmission buffer will clear itself and wait for a true level on the CTS line or an Xon command on the RXD line before filling again. This is to prevent the transmission of old data in the event that the user indefinitely suspends data transmission. A “232 Er” message will appear periodically on the display warning of a data transmission problem. When transmission resumes after such a buffer clearing a “Transmission Break” message will be transmitted before new data appears, indicating there has been a gap in data transmission.

Data from the WAVEMETER_{jr} is transmitted at 2400 Baud on the “Transmit Data” (TXD:pin#3) line. The data transmission format is a single start bit followed by an 8-bit ASCII character; starting with the least significant bit (LSB) and ending with the most significant bit (MSB). This 8-bit ASCII character is followed by 2 stop bits for a total of 11 bits, no parity. The maximum line length is 22 characters followed by carriage return/line feed (CR/LF) characters indicating the end of each line of data.

NOTE: Appendix A contains a sample program for communicating with the Wavemeter_{jr} via RS-232.

3.11 INTERFEROMETER ALIGNMENT

Figure 1.1 shows the physical layout of the internal Michelson interferometer. Only one end mirror is adjustable and it can be aligned using a small flat blade screwdriver through two access holes in the rear panel.

Normally, major interferometer alignment should not be necessary. However, slight adjustments to the ALIGNMENT screws may be useful to optimize the sensitivity of the Wavemeter_{jr} for low intensity laser sources.

If major realignment of the Michelson interferometer is required, refer to Figure 3.6 and use the following procedure:

1. Turn off the Wavemeter_{jr} and disconnect the AC line cord.
2. Remove the top cover of the chassis. It is secured by 2 black screws in each side. Carefully detach the ribbon cable connector on the main circuit board that provides power to the display panel.
3. Remove the silver dust cover from the interferometer, which is secured by one top screw.
4. Disconnect the 6-conductor ribbon cable from the Detector Board and remove the single mounting screw that secures the board. Carefully lift the board from the black plastic guide at its base.
5. Align the beam receiver with a HeNe laser and observe the laser beam that would normally hit the detector by placing a white card just beyond where the detector mounts, as shown in Figure 3.6.
6. Adjust the end mirror alignment until the spots observed on the white card are superimposed. Interference fringes will be evident when the spots are superimposed. Adjust the alignment until only one broad fringe exists.

7. Replace the detector board dust cover, chassis cover and AC line cord.
8. Turn on the Wavemeter_{jr} and fine adjust the end mirror alignment to maximize the intensity level on the bar-graph meter or the MONITOR output.

NOTE: If you have difficulty obtaining enough signal to activate the bar-graph meter, connect an oscilloscope to the MONITOR and TRIGGER outputs for greater sensitivity in detecting the fringe signal.

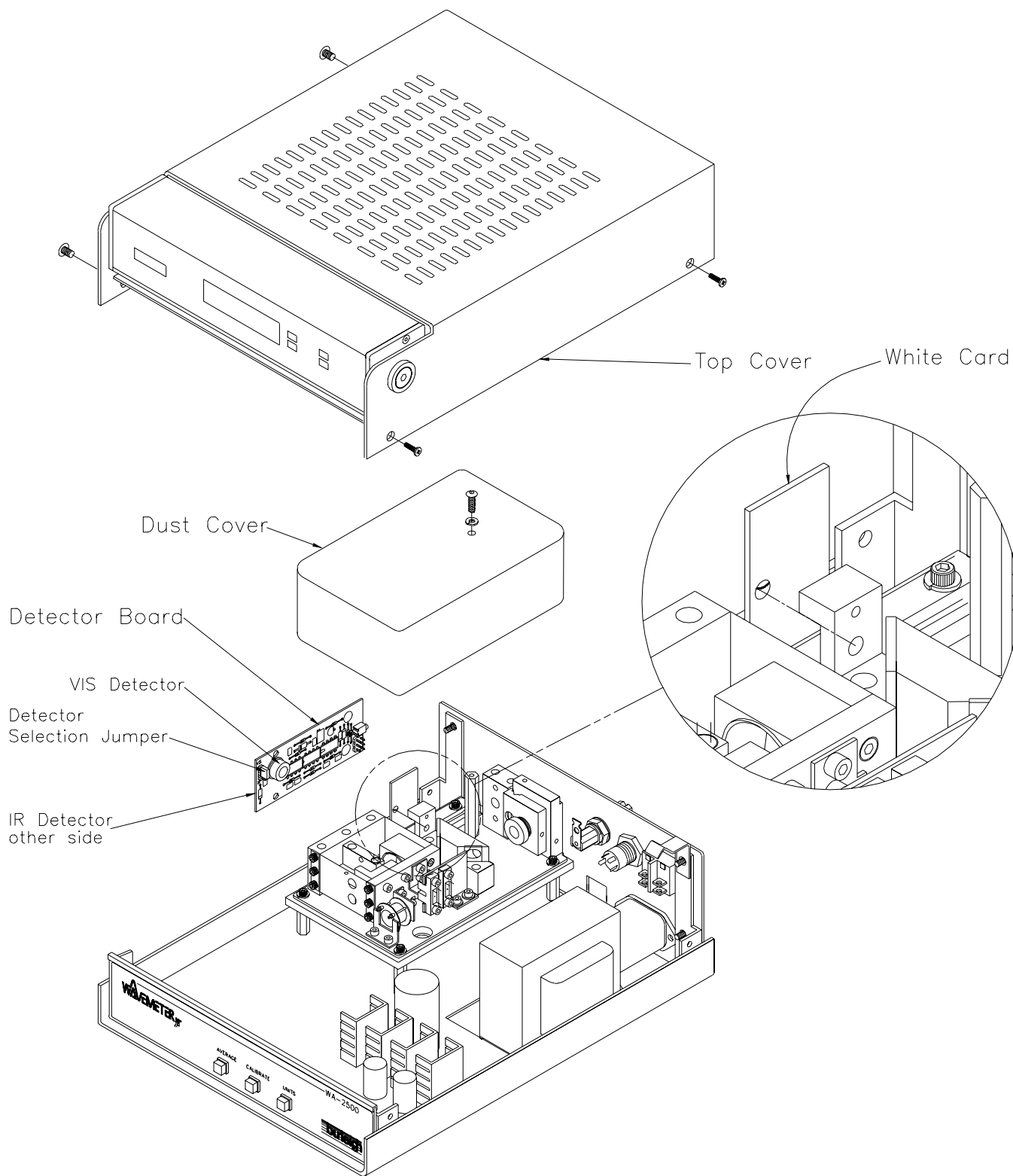

Figure 3.6. Wavemeter_{jr} Exploded View.

3.12 DETECTOR INTERCHANGE

The Model WA-2500 uses two detectors (Si and Ge) mounted on a common circuit board. The Detector Board must be oriented in its mounting slot to position the appropriate detector in the beam path. The Si detector is recommended for 400-1000 nm (VIS) operation, but can detect radiation to 1100 nm. The Ge detector is recommended for the 1000-1800 nm (IR) wavelength range, but can detect radiation to 600 nm. The relative sensitivity of both detectors is shown graphically in Figure 3.7. An LED mounted to the Detector Board illuminates the appropriate rear panel window to identify which detector is in position. Either detector can be used to check or perform a calibration of the Wavemeter_{jr} at 632.8 nm.

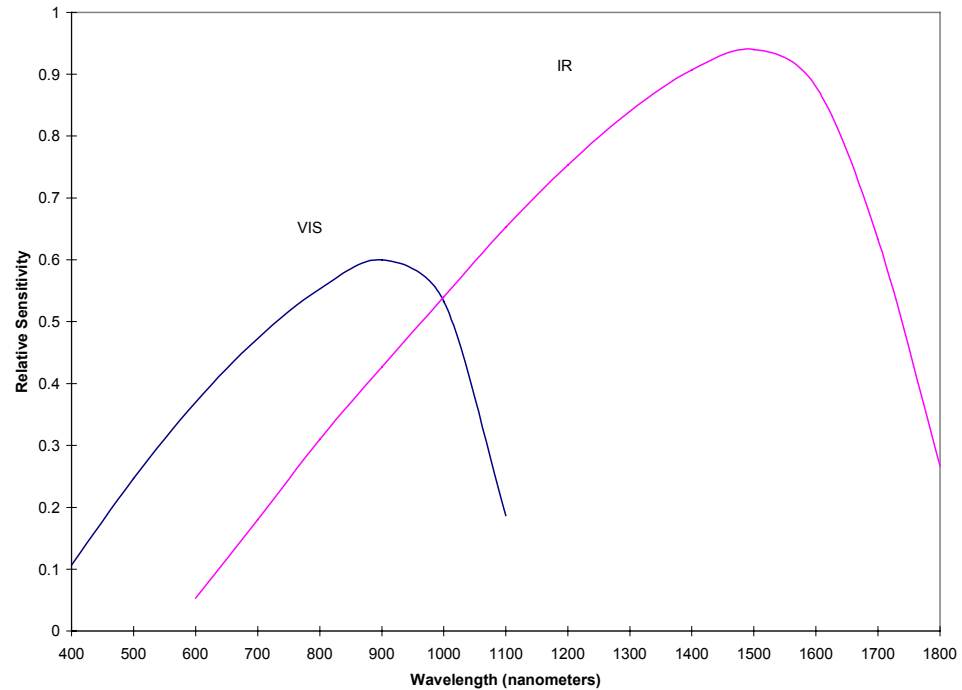

Figure 3.7. Relative Sensitivity of the Si and Ge Detectors.

To switch the WA-2500 from VIS to IR operation (or vice versa), refer to Figure 3.6 and use the following procedure:

1. Turn off the Wavemeter_{jr} and disconnect the AC line cord.
2. Remove the top cover of the chassis secured by 2 black screws on each side. Carefully detach the ribbon cable connector between the main circuit board and the display panel.
3. Remove the silver dust cover from the interferometer that is secured by one top screw.
4. Disconnect the 6-conductor ribbon cable from the Detector Board and remove the single mounting screw that secures the Board. Carefully lift the Detector Board from the black plastic guide at its base.

5. Change the jumper.
 - For VIS operation put the shunt on the middle pin and the pin closest to the VIS label on the board.
 - For IR operation put the shunt on the middle pin and the pin closest to the IR label on the board.
6. Insert the Board so the appropriate detector faces the beam aperture in the Detector Board mounting bracket. The VIS detector is on the side of the board with the jumper and other circuit components. The IR detector is on the opposite side.
7. Secure the Board with its mounting screw and reconnect the ribbon cable on the 6-pin header facing the ribbon cable.
8. Replace the dust cover, chassis cover and AC line cord.

When the Wavemeter_{jr} is turned on, the DETECTOR LED should illuminate the appropriate window in the rear panel.

3.13 100 VAC OPERATION

All Wavemeter_{jr} models manufactured after September 1988 include a provision for altering the connections to the main transformer for operation at a line voltage of 100 VAC \pm 10%, 50/60 Hz.

WARNING: Before attempting to change the connections to the transformer, make certain that the Wavemeter_{jr} is turned off and the AC line cord is unplugged from the rear panel receptacle. Dangerous voltages exist on the transformer terminals when power is applied.

Figure 3.8 shows the transformer terminals numbered 1 through 6 as viewed from the transformer side of the chassis.

Transformer connections for:

100/200 VAC*:	Black wire to pin #2
	Red wire to pin #5
115/230 VAC*:	Black wire to pin #1
	Red wire to pin #4

* Selection determined by rear panel 115/230 selector switch.

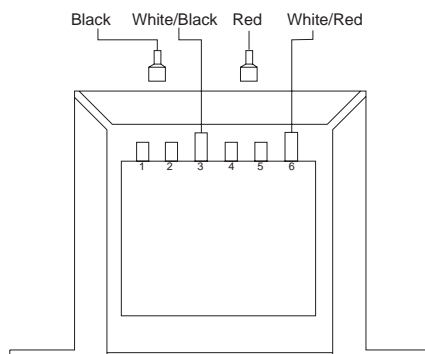

Figure 3.8. Transformer Connections.

3.14 OPERATION WITH MODE-LOCKED AND OTHER LOW COHERENCE LASERS

The Wavemeter_{jr} can measure the wavelength of most mode-locked CW lasers when the following considerations are met.

NOTE: **Mode-locked lasers produce peak powers that are typically 1000-10,000 times greater than their average output power. These lasers can permanently damage the fiber optic cable when such high power is focused inside the fiber by the beam receiver. To avoid such damage the average power incident on the beam receiver head should be kept under 10 milliwatts. Reflecting the beam off one or more uncoated glass beamsplitters provides one simple means of reducing the beam power to an acceptable level.**

The short pulse output of a mode-locked laser results in a broad spectral linewidth as depicted in the middle pattern of Figure 3.3. The reduced coherence associated with this broad linewidth produces a fringe envelope observed on the MONITOR signal that is short in duration. The maximum of the fringe envelope occurs at the point in the scan where both paths through the interferometer are equal in length. For proper operation of the Wavemeter_{jr}, the TRIGGER pulse should start near the maximum of this fringe envelope. This condition is factory set for a laser source operating at 800 nm, but may require slight readjustment for other wavelengths if the MONITOR signal envelope is very short.

First display the MONITOR signal for the broad linewidth laser and the TRIGGER signal simultaneously on an oscilloscope. Determine if the TRIGGER pulse begins before or after the peak of the MONITOR fringe envelope and by how much in milliseconds.

Refer to Figure 3.6 and use the following procedure to set the correct optical path length:

1. Turn off the Wavemeter_{jr} and disconnect the AC line cord.
2. Remove the top cover of the chassis secured by two black screws on each side. Carefully detach the ribbon cable connector between the main circuit and the display panel.
3. Remove the silver dust cover from the interferometer that is secured by one top screw.
4. Locate the knurled mirror holder in the adjustable mirror mount next to the rear panel. Mark the existing 12 o'clock position on the face of the knurled mirror holder with a felt tipped marker pen.
5. On the side of the mirror mount facing the transformer, use a 1/16" hex wrench to loosen the set screw that secures the threaded section of the knurled mirror holder.
6. If the TRIGGER pulse began before the peak of the MONITOR envelope, rotate the mirror holder ½ turn counterclockwise for each millisecond difference. If the TRIGGER pulse began after the peak of the MONITOR envelope, rotate the mirror holder ½ turn clockwise for each millisecond difference.
7. Secure the mirror holder by tightening the set screw on the side of the mount.
8. Introduce a HeNe laser input to the beam receiver and realign the interferometer as described in Section 3.11.

9. Replace the dust cover, chassis cover and AC line cord.

Check again the relative timing of the peak of the MONITOR signal envelope and the start of the TRIGGER pulse for the broad linewidth laser. Repeat the above procedure if further correction is necessary.

4. MAINTENANCE AND SERVICE

Other than the procedures in this manual, user repairs and maintenance are not recommended. If any problems arise, or if you have any questions, please contact the Burleigh Customer Service Department.

WARNING: Always disconnect the AC line cord before removing the top cover and reconnect power only as necessary for testing.

4.1 ERROR MESSAGES

The following error messages may appear on the front panel display and RS-232 interface.

Message	Description
CAL	Calibration of the Moiré interferometer gauge is in process.
FAIL	Attempted calibration process failed. Previous calibration value remains stored in non-volatile memory. Calibration requires a red HeNe laser input.
HI SIG	Input laser power is too high.
LO SIG	Input laser power is too low.
PLL Er	Phase-locked loop error. Wavemeter _{jr} must be placed on a firm and stable horizontal surface. This error can be caused by vibrations or perturbations to the internal scan mechanism.
COH Er	Coherence error of the laser under test. This error may result from laser linewidths greater than 3000 GHz (100 cm ⁻¹) or from lasers with large amplitude noise and power drop out.
LOP Er	Low power on the battery back-up for non-volatile memory. This message will appear preceding the countdown from 10 when power is first turned on. If this message appears the memory chip should be replaced. Please consult Burleigh for more information.
232Er	Data transmission via the RS-232 interface has been halted by a CTS line "false" or Xoff command. This warning may also indicate an incorrect termination of the RS-232 interface cable.
ALI Er	Interferometer alignment error. Input laser power is high but signal amplitude is too low because the interferometer is misaligned. Refer to Section 3.11.

4.2 TROUBLESHOOTING

Symptom	Corrective Procedure.
Blown fuse	Check 115/230 VAC selector switch. Replace fuse. If fuse blows again, disconnect transformer from main circuit board at P1 and try new fuse to determine if transformer is bad.
No display	Check fuse. Check display panel is connected to main circuit board at P3. Verify low voltage power supply is good. The red LED on the circuit board should be lit and the test point voltages relative to the GND test point (TP6) should be: TP1 = + 5 volts TP2 = + 12 volts TP3 = - 12 volts TP4 = + 5 volts
Display is very weak	Check 115/230 VAC selector switch. Verify + 5 volts at TP4.
VIS/IR on rear panel not lit.	Check that Detector Board connector is attached.
ALI Er	Realign interferometer (refer to Section 3.11).
HI SIG but bar-graph not fully lit.	Check MONITOR signal character for extreme amplitude variations or laser instability. Realign interferometer (Refer to Section 3.11).
PLL Er	Check that the Moiré gauge signal at TP5 exceeds 2 volts peak-to-peak throughout the TRIGGER interval. Verify that the interferometer scan assembly swings freely without touching other components, approximately 9 mm travel.
Display is frozen on zero after power up.	Check that the solenoid releases the scan mechanism on power up. The solenoid is located below the interferometer. Verify that the interferometer scan assembly swings freely without touching other components, approximately 9 mm travel.
LO SIG displayed for input power of several milliwatts	Check the beam receiver alignment. (Section 3.3.) Check the fiber optic cable for damage, or dirt on the ends, that might reduce its transmission. Check interferometer alignment (Section 3.11). Check that the Detector Board jumper is set correctly for the VIS or IR detector (Section 3.12).
Displayed value changes erratically	Reflection from the beam receiver is destabilizing the laser. Check the MONITOR signal and slightly misalign the beam receiver. Laser stability may also be affected by feedback from other optical components in the beam.
Displayed value is incorrect	Calibration error. See Section 3.7 to recalibrate. Noise on the laser input is interpreted as part of the fringe signal. As you view the MONITOR signal, reduce the input power until the amplitude noise following the fringe envelope is less than 0.5 volts peak-to-peak.

4.3 CHANGING THE LINE VOLTAGE

To change the line voltage, you have to rotate the fuse holder so the desired voltage (115VAC or 230VAC) is on top. In the 115VAC position, mount the fuse on the right side of the holder (Figure 4.1) and the adapter clip on the left (Figure 4.2). In the 230VAC position, remove the adapter clip (Figure 4.2) and insert a second fuse in its place.

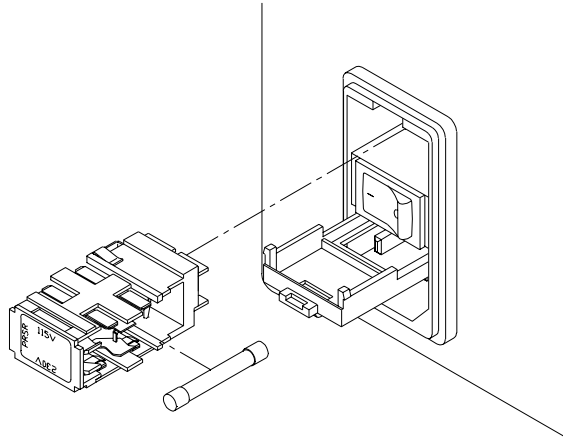

Figure 4.1. Primary Power Module.

4.4 CHANGING THE FUSE

To change the fuse, you have to remove the fuse holder (Figure 4.1).

The fuse holder can hold either $\frac{1}{4}$ " x $1\frac{1}{4}$ " or 5x20mm style fuses, and can be used for either single line or dual line fusing.

115 VAC operation requires single line fusing, and the adapter clip (Figure 4.2) must be in place on the side marked PRSR.

230 VAC operation requires dual line fusing. In the 230 VAC position, the fuse holder will not fit into the power module with the adapter clip in place. The adapter clip must be removed and replaced by a second fuse.

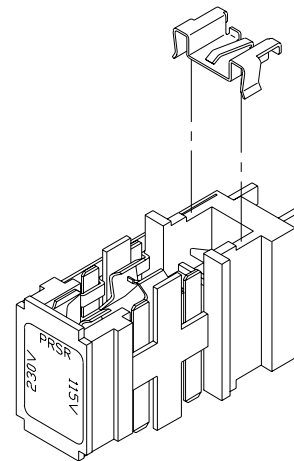

Figure 4.2. Fuse Holder.

5. ACCESSORIES

5.1 RECOMMENDED MOUNTS

The Wavemeter_{jr} does not include an optical mount for holding the beam receiver accessory because many commercial mounts are available from different manufacturers that satisfy the alignment requirements of the Wavemeter_{jr}. In most situations, a simple mount for 25 mm diameter optics with θ and ϕ adjustments is sufficient. Several commercial mounts are listed below.

Manufacturer	Model Number(s)	Type
Ardel Kinematic	#19245	Base
Ardel Kinematic	#19246	Post
Ealing	#22-2125 with #22-8346 adapter	Base
Melles Griot	#07 MHT 007	Base
Melles Griot	#07 MHT 003	Post
New Focus	#9802	Post
New Focus	#9804	Post
Newport	MM2-1A with SP post MM2-1A with BP-2 base	Post Base
Newport	GM-1 with SP post GM-1 with BP-4 base	Post Base
Oriel	#14002 with post	Post
Spindler & Hoyer	#06-5074 with #06-5078 adapter and post	Post

Optical mounts with X-Y as well as θ , ϕ adjustments may be convenient in some laboratory situation. However, basic θ , ϕ adjustments are usually sufficient.

NOTE: The beam receiver is also available with a mounting diameter of 30 mm (Product Code, BC-3). Consult your Burleigh representative for more information.

5.2 OPTIONAL COMPONENTS

Laser sources that are pig tailed to fibers terminated with other fiber optic connectors can be coupled directly into the Wavemeter_{jr} by a special fiber optic cable that adapts that style of connector to the FC input connector on the WA-2500. Contact your Burleigh representative for more information.

6. SPECIFICATIONS

Model Number	WA-2500
Wavelength Range	400 - 1800 nm
Accuracy	± 1 part in 10,000
At 1000 nm:	0.1 nm (1 cm ⁻¹)
Display Resolution*	0.01 nm (0.1 cm ⁻¹)
Display Units	Nanometers or wavenumbers in vacuum or air
Display Update Period	
Normal Mode:	0.2 seconds
Average Mode	2 seconds
Input Power**	20 microwatts
Beam Receiver Accessory	
Coupling Head Aperture:	2.5 millimeter
Patch cord Cable Length:	3 meters
RS-232 Interface	Standard (2400 Baud)
AC Power	100/115/230 VAC ± 10%
Line Frequency	50/60 Hz
Fuse	1/2 A, slow-blow
Weight	4.0 Kilograms
Dimensions (mm)	110 H × 220 W × 280 L

Notes:

* Display resolution is adjusted automatically depending on the linewidth of the measured light.

** Input power requirement is specified as power out of the fiber and into the instrument. For a collimated beam with a diameter 2.5 mm, coupling into the standard beam receiver is usually greater than 30%.

7. WARRANTY

The Burleigh Wavemeter_{jr} is warranted against defects in material and workmanship for a period of one year after date of delivery and the return of Burleigh's warranty card. The beam receiver and fiber optic cables are warranted for a period of three months from date of delivery. During the warranty period, Burleigh will repair or, at its option, replace parts which prove defective when the instrument is returned prepaid to Burleigh Instruments, Inc.

Before return of an instrument, please call Burleigh for return authorization. The warranty will not apply if the instrument has been damaged by accident, misuse, or as a result of modification by persons other than Burleigh personnel.

The liability of Burleigh Instruments, (except as to title) arising out of supplying of said product, or its use, whether under the foregoing warranty, a claim of negligence, or otherwise, shall not in any case exceed the cost of correcting defects in the products as herein provided. Upon expiration of the warranty period specified herein, all liability shall terminate. The foregoing shall constitute the sole remedy of the buyer. In no event shall the seller be liable for consequential or special damages.

APPENDIX A. SAMPLE PROGRAM

This Appendix contains an illustrative sample program for receiving data from the Wavemeter_{jr} and displaying it on a computer. You can copy and compile this program as written, or embed sections in your own program as needed to suit the application.

```
// filename - wavewmtr.c
// copyright 1995 Burleigh Instruments
// #####-#-## Rev.A
// Assembly:
// Compiler/Assembler

// Description

// this code was written using Microsoft C/C++ language
// it has been tested using the WA2500
// the example is intended to be illustrative not exhaustive

// The _bios_serialcom routine uses INT 0x14 to provide serial communications
// services. The serial_port parameter is set to 0 for COM1, to 1 for COM2,
// and so on.

// The service parameter can be set to one of the following constants:

// _COM_INIT - Sets the port to the specified parameters
// _COM_SEND - Transmits the data characters over the selected serial port
// _COM_RECEIVE - Accepts an input character from the selected serial port
// _COM_STATUS - Returns the current status of the selected serial port

// The data parameter is ignored if service is set to _COM_RECEIVE or
// _COM_STATUS. The data parameter for _COM_INIT is created by combining
// (with the OR operator) one or more of the following constants:

// _COM_CHR7    7 data bits
// _COM_CHR8    8 data bits
// _COM_STOP1   1 stop bit
// _COM_STOP2   2 stop bits
// _COM_NOPARITY No parity
// _COM_EVENPARITY Even parity
// _COM_ODDPARITY Odd parity
// _COM_110     110 baud
// _COM_150     150 baud
// _COM_300     300 baud
// _COM_600     600 baud
// _COM_1200    1200 baud
// _COM_2400    2400 baud
// _COM_4800    4800 baud
// _COM_9600    9600 baud

// The function returns a 16-bit integer whose high-order byte contains status
// bits. The meaning of the low-order byte varies, depending on the service
// value. The high-order bits have the following meanings:
```

```
// Bit Meaning if Set
// 15 Timed out
// 14 Transmission-shift register empty
// 13 Transmission-hold register empty
// 12 Break detected
// 11 Framing error
// 10 Parity error
// 9  Overrun error
// 8  Data ready

// When service is _COM_SEND, bit 15 will be set if data could not be sent.
// When service is _COM_RECEIVE, the byte read will be returned in the
// low-order bits if the call is successful. If an error occurs, any of the
// bits 9, 10, 11, or 15 will be set.

// When service is _COM_INIT or _COM_STATUS, the low-order bits are defined
// as follows:

// Bit Meaning if Set
// 7  Receive-line signal detected
// 6  Ring indicator
// 5  Data set ready
// 4  Clear to send
// 3  Change in receive-line signal detected
// 2  Trailing-edge ring indicator
// 1  Change in data-set-ready status
// 0  Change in clear-to-send status

// Note that this function works only with IBM personal computers and true
// compatibles.

// The following is a straight forward example showing how to communicate
// with the WA2500. It demonstrates bi-directional communication
// using variable field ASCII formatted strings.

// The Wavemeter responds with up to a 24 character space delimited variable
// field formatted string. The terminating characters are always CR (0x0D)
// carriage return and LF (0x0A) line feed pair. The 1st field contains the
// wavelength or status code. The 2nd field indicates the units being
// displayed. The 3rd field indicates whether the units are vacuum or air
// units.

#include <bios.h>
#include <conio.h>
#include <graph.h>
#include <stdio.h>
#include <stdarg.h>
#include <string.h>

// misc defines
#define ERROR_MASK 0x8E00
#define XMIT_MASK 0x0610
#define CHAR_MASK 0x00FF
#define STATUS_MASK 0x0FF00
#define ESC 0x1B
```

```

#define CR 0x0D
#define LF 0x0A
#define FALSE 0
#define TRUE !(FALSE)

typedef int BOOL;

// boolean
BOOL bOnline;

// rs232 buffer
char cRS232Buffer[64];
char cPreviousRS232Buffer[64];

// example commands
char sXON[] = "\x11\r\n";
char sXOFF[] = "\x13\r\n";

// misc vars
char sBlanks[] = "          \0";
short n;
short nChar = 0x0;
short nCommStatus;
short nKeyCode = 0x0;
unsigned wCommPort;

// misc routines
void displaytitles(void);
void displaydata(void);
short sendcommand(unsigned, char *, short);

void main (int argc, char *argv[]) {

    if(argc == 2) {
        // initialize variables
        cRS232Buffer[0] = '\0';

        // initialize display
        _clearscreen(_GCLEARSCREEN);
        _displaycursor(_GCURSOROFF);

        displaytitles();

        // determine which comm port
        if(strcmp(argv[1], "COM1") == 0)
            wCommPort = 0;
        else if(strcmp(argv[1], "COM2") == 0)
            wCommPort = 1;
        else if(strcmp(argv[1], "COM3") == 0)
            wCommPort = 2;
        else if(strcmp(argv[1], "COM4") == 0)
            wCommPort = 3;
        else {
            _clearscreen(_GCLEARSCREEN);
            printf("usage: wavewmtr <COM#>\n");
        }
    }
}

```

```

    return;
}

// init RS232 port COM2, 2400 baud, 8 data bits, no parity, 2 stop bit
nCommStatus = _bios_serialcom(_COM_INIT, wCommPort,
    _COM_2400|_COM_CHR8|_COM_NOPARITY|_COM_STOP2);

if(!(nCommStatus&ERROR_MASK)) {
    for(n = 0; n < (short)strlen(sXON); n++) {
        nCommStatus = _bios_serialcom(_COM_SEND, wCommPort, sXON[n]);
    }
    if(!(nCommStatus&ERROR_MASK))
        bOnline = TRUE;
}
else {
    printf("usage: wavewmtr <COM#>\nCOM error...\n");
    return;
}

// loop until the Esc key is pressed
do {
// parse keystroke
    switch(nKeyCode) {
        case 'x':
        case 'X':
            bOnline = !bOnline;
            if(bOnline)
                nCommStatus = sendcommand(wCommPort, (char *)sXON, strlen(sXON));
            else
                nCommStatus = sendcommand(wCommPort, (char *)sXOFF, strlen(sXOFF));
            break;

        default:
            break;
    }

// continue reading rs232 while !keystroke
    while (!kbhit()) {
        if(bOnline) {
// read rs232
            n = 0;
            while((nChar = _bios_serialcom(_COM_RECEIVE, wCommPort, 0)) != 0x0A
                && !(nChar&ERROR_MASK)) {
                cRS232Buffer[n++] = nChar&CHAR_MASK;
            }
            if(nChar&ERROR_MASK)
                nCommStatus = nChar&ERROR_MASK;
            else
                nCommStatus = nChar&STATUS_MASK;
        }
        else {
            strcpy(cRS232Buffer, "Offline\0");
        }

        if(n == 7 || n == 23 || (nCommStatus&ERROR_MASK)) {

```

```

// display result
    displaydata();
}

// reinitialize variables
    cRS232Buffer[0] = '\0';
}
} while ((nKeyCode = _getch()) != ESC);

    _clearscreen(_GCLEARSCREEN);
    _displaycursor(_GCURSORON);
}
else {
    _clearscreen(_GCLEARSCREEN);
    printf("usage: wavemtr <COM#>\n");
}
}

// sends command string out serial port
short sendcommand(unsigned wComPort, char *pString, short nStringLen) {
short i;
short nComStatus;

for(i = 0; i < nStringLen; i++) {
    while (!(nComStatus = _bios_serialcom(_COM_STATUS, wComPort, 0)
        &(ERROR_MASK|XMIT_MASK)));
        nComStatus = _bios_serialcom(_COM_SEND, wComPort, pString[i]);
}

return(nComStatus);
}

void displaytitles(void) {
    _settextposition(1, 1);
    printf("Burleigh Instruments WA2500 RS232 Interface Example Program");
    _settextposition(3, 1);
    printf("Raw RS232 Data");
    _settextposition(5, 1);
    printf("Wavelength");
    _settextposition(7, 1);
    printf("Units");
    _settextposition(9, 1);
    printf("Medium");
    _settextposition(11, 1);
    printf("RS232 Status");
    _settextposition(14, 1);
    printf(" Esc - to exit program; X - to toggle interface On/Off line");
}

// displays data
void displaydata(void) {

```



```

char *pSorc;

if(bOnline || (strcmp(cPreviousRS232Buffer, cRS232Buffer) != 0)) {
// clear out previous data
  _settextposition(4, 1);
  printf("%.32s", sBlanks);

// remove LF's
  while((pSorc = strstr(cRS232Buffer, "\n")) != 0) {
    *pSorc = ' ';
  }

// display raw data
  _settextposition(4, 1);
  if(!(nChar&ERROR_MASK))
    printf("  %.23s", cRS232Buffer);

// parse string for errors
  _settextposition(6, 1);
  if(strstr(cRS232Buffer, "CAL") == 0
    && strstr(cRS232Buffer, "FAIL") == 0
    && strstr(cRS232Buffer, "SIG") == 0
    && strstr(cRS232Buffer, "Er") == 0
    && !(nChar&ERROR_MASK) && bOnline) {
    printf("  %.7s", cRS232Buffer);
  }
  else {
    printf("%.32s", sBlanks);
  }

// check units
  _settextposition(8, 1);
  if((pSorc = strstr(cRS232Buffer, "NANOMETERS")) != 0
    || (pSorc = strstr(cRS232Buffer, "INVERSE")) != 0) {
    printf("  %.10s", pSorc);
  }
  else {
    printf("%.32s", sBlanks);
  }

// check medium
  _settextposition(10, 1);
  if((pSorc = strstr(cRS232Buffer, "AIR")) != 0
    || (pSorc = strstr(cRS232Buffer, "VAC")) != 0) {
    printf("  %.3s", pSorc);
  }
  else {
    printf("%.32s", sBlanks);
  }

// display status
  _settextposition(12, 4);
  printf("0x%.4X", nCommStatus);

  strcpy(cPreviousRS232Buffer, cRS232Buffer);

```

```
}  
else if(!bOnline) {  
    _settextposition(4, 1);  
    printf("  Offline%.32s", sBlanks);  
}  
}
```

INDEX

- 100 VAC Operation, 3-13
- Accessories, 5-1
- Applications, 1-1
- Auto-Resolution, 1-2, 3-6, 3-7
- Average Mode, 3-4
- Bar-Graph Intensity Meter, 3-4
- Beam Receiver
 - Alignment, 3-2
 - Mounting, 3-1
- Calibration, 3-5, 4-1
- Changing the Fuse, 4-3
- Changing the Line Voltage, 4-3
- Detector Interchange, 3-12
- Error Messages, 4-1
- Front Panel, 2-2
- Functional Check, 2-1
- Fuse Holder, 4-3
- Inspection
 - Operational, 2-1
 - Visual, 2-1
- Interferometer Alignment, 3-9
- Introduction, 1-1
- IR Detector, 1-1, 2-2, 3-12, 3-13, 4-2
- Line Voltage Selector, 4-3
- Low Coherence Lasers, 3-14
- Maintenance, 4-1
- Mode-Locked CW Lasers, 3-14
- Moiré gauge, 1-1, 4-1, 4-2
- Monitor Output, 3-5
- Operating Instructions, 3-1
- Optional Components, 5-2
- Output
 - Monitor, 3-5
 - Trigger, 3-5
 - Window, 3-5
- Primary Power Module, 4-3
- Rear Panel, 2-2
- Recommended Mounts, 5-1
- RS-232 Interface, 3-8, 4-1
- Service, 4-1
- Set Up, 3-1
- Specifications, 6-1
- Theory of Operation, 1-1
- Transformer Connections, 3-13
- Trigger Output, 3-5
- Troubleshooting, 4-2
 - Error Messages, 4-1
- Units Selection, 3-4
- VIS Detector, 1-1, 2-2, 3-12, 3-13, 4-2
- Warranty, 7-1
- Wavemeterjr Layout, 1-2
- Window Output, 3-5

burleigh

Burleigh Instruments, Inc.
Burleigh Park
P.O. Box E
Fishers, NY 14453-0755
Tel. (716) 924-9355
Fax. (716) 924-9072

Wavemeter_{jr}
04659-M-00



Artisan Technology Group is your source for quality new and certified-used/pre-owned equipment

- FAST SHIPPING AND DELIVERY
- TENS OF THOUSANDS OF IN-STOCK ITEMS
- EQUIPMENT DEMOS
- HUNDREDS OF MANUFACTURERS SUPPORTED
- LEASING/MONTHLY RENTALS
- ITAR CERTIFIED SECURE ASSET SOLUTIONS

SERVICE CENTER REPAIRS

Experienced engineers and technicians on staff at our full-service, in-house repair center

*InstraView*SM REMOTE INSPECTION

Remotely inspect equipment before purchasing with our interactive website at www.instraview.com ↗

WE BUY USED EQUIPMENT

Sell your excess, underutilized, and idle used equipment. We also offer credit for buy-backs and trade-ins. www.artisanng.com/WeBuyEquipment ↗

LOOKING FOR MORE INFORMATION?

Visit us on the web at www.artisanng.com ↗ for more information on price quotations, drivers, technical specifications, manuals, and documentation

Contact us: (888) 88-SOURCE | sales@artisanng.com | www.artisanng.com