



Artisan Technology Group is your source for quality new and certified-used/pre-owned equipment

- FAST SHIPPING AND DELIVERY
- TENS OF THOUSANDS OF IN-STOCK ITEMS
- EQUIPMENT DEMOS
- HUNDREDS OF MANUFACTURERS SUPPORTED
- LEASING/MONTHLY RENTALS
- ITAR CERTIFIED SECURE ASSET SOLUTIONS

SERVICE CENTER REPAIRS

Experienced engineers and technicians on staff at our full-service, in-house repair center

*InstraView*SM REMOTE INSPECTION

Remotely inspect equipment before purchasing with our interactive website at www.instraview.com ↗

WE BUY USED EQUIPMENT

Sell your excess, underutilized, and idle used equipment. We also offer credit for buy-backs and trade-ins. www.artisanng.com/WeBuyEquipment ↗

LOOKING FOR MORE INFORMATION?

Visit us on the web at www.artisanng.com ↗ for more information on price quotations, drivers, technical specifications, manuals, and documentation

Contact us: (888) 88-SOURCE | sales@artisanng.com | www.artisanng.com



LC20 CHROMATOGRAPHY ENCLOSURE OPERATOR'S MANUAL

© 1993 Dionex Corporation

Document No. 034859
Revision 02
September 1993

© 1993 Dionex Corporation
All rights reserved worldwide
Printed in the United States of America

This publication is protected by federal copyright law. No part of this publication may be copied or distributed, transmitted, transcribed, stored in a retrieval system, or transmitted into any human or computer language, in any form or by any means, electronic, mechanical, magnetic, manual, or otherwise, or disclosed to third parties without the express written permission of Dionex Corporation, 1228 Titan Way, Sunnyvale, California 94088-3603.

DISCLAIMER OF WARRANTY AND LIMITED WARRANTY

THIS PUBLICATION IS PROVIDED “AS IS” WITHOUT WARRANTY OF ANY KIND. DIONEX CORPORATION DOES NOT WARRANT, GUARANTEE, OR MAKE ANY EXPRESS OR IMPLIED REPRESENTATIONS REGARDING THE USE, OR THE RESULTS OF THE USE, OF THIS PUBLICATION IN TERMS OF CORRECTNESS, ACCURACY, RELIABILITY, CURRENTNESS, OR OTHERWISE. FURTHER, DIONEX CORPORATION RESERVES THE RIGHT TO REVISE THIS PUBLICATION AND TO MAKE CHANGES FROM TIME TO TIME IN THE CONTENT HEREIN WITHOUT OBLIGATION OF DIONEX CORPORATION TO NOTIFY ANY PERSON OR ORGANIZATION OF SUCH REVISION OR CHANGES.

TRADEMARKS

DX-LAN™, Self-Regenerating Suppressor™, SRS™, and ThermoFlare™ are trademarks of Dionex Corporation.
Teflon™ and Tefzel™ are registered trademarks of E.I. du Pont de Nemours and Company.

PRINTING HISTORY

Revision 01, August 1993
Revision 02, September 1993

Contents

1 • Introduction

1.1	Overview	1-3
1.2	About This Manual	1-3
1.3	Product Safety Information	1-4

2 • Description

2.1	Overview	2-3
2.2	Front Panel	2-3
2.2.1	Rheodyne Injection Valve	2-3
2.3	Interior Layout	2-4
2.3.1	Component Panel	2-5
2.3.2	Rheodyne Injection Valve	2-6
2.3.3	Self-Regenerating Suppressor	2-7
2.3.4	Leak Sensor	2-7
2.3.5	Separator Columns	2-7
2.3.6	Guard Columns	2-7
2.3.7	Column Select Valve	2-8
2.3.8	Detector Cells	2-11
2.3.9	DS3 Detection Stabilizer (Optional)	2-11
2.4	Rear Panel	2-12
2.4.1	Cell Cables	2-13
2.4.2	Waste Line	2-13

2.4.3 Solenoid Interface 2-13

3 • Service and Maintenance

3.1 Routine Operation 3-3
 3.1.1 Sample Loading 3-4
3.2 Shutdown 3-7
3.3 Routine Maintenance 3-7

4 • Troubleshooting

4.1 Liquid Leaks 4-3
4.2 Excessive System Backpressure 4-4
4.3 Inoperative Column Select Valve 4-5
4.4 Column Select Valve Air Leaks 4-5
4.5 Peak Ghosting 4-6
4.6 Non-Reproducible Peak Height or Retention
 Time 4-6
4.7 Abnormal Retention Time or Selectivity 4-6

5 • Service

5.1 Introduction 5-3
5.2 Tube Fitting Installation 5-3
5.3 Restriction in the Hydraulic System 5-4
5.4 Injection or Column Select Valve Liquid Leaks 5-4
5.5 Column Select Valve Air Leaks 5-5

5.6	Cleaning the Column Select Valve Slider	5-6
5.7	Replacing Column Select Valve Port Face	5-9
5.8	Servicing the Rheodyne Injection Valve	5-9

A • Specifications

A.1	Environmental	A-3
A.2	Physical	A-3
A.3	Hydraulics	A-3
A.4	Insulation	A-4

B • Installation

B.1	Facilities Required	B-3
B.2	Installation Instructions	B-4
B.2.1	Stacking Modules	B-4
B.2.2	Waste Lines	B-5
B.2.3	Leak Control	B-6
B.2.4	Liquid Line Connections	B-6
B.2.5	Detector Cells	B-9
B.2.6	Column Installation	B-12
B.2.7	SRS Installation (Optional)	B-13
B.2.8	Solenoid Valve Connections to the Pump	B-14

Contents

1 • Introduction

1.1	Overview	1-3
1.2	About This Manual	1-3
1.3	Product Safety Information	1-4

LC20 Chromatography Enclosure

1.1 Overview

The LC20 Chromatography Enclosure is an integral part of the Dionex DX 500 Chromatography Systems. It can house the following system components, which must be ordered separately or as part of another module: Separator columns, optional guard columns, SRS™ (Self-Regenerating Suppressor), DS3 Detection Stabilizer, and detector cell(s) for the ED40 Electrochemical Detector and CD20 Conductivity Detector.

The LC20 is available in two configurations, depending on the type of injection valve installed:

- LC30, PEEK automated injection valve (P/N 044088)
- LC30, stainless steel automated injection valve (P/N 044171)

1.2 About This Manual

This manual describes the operation, maintenance, and use of the LC20 Chromatography Enclosure.

Chapter 1, **Introduction**, introduces the product and conventions used in the manual, and provides safety information.

Chapter 2, **Description**, is a description of the physical aspects of the LC20 Chromatography Enclosure, followed by a functional description of the operating features.

Chapter 3, **Operation and Maintenance**, discusses the operating features and routine maintenance.

Chapter 4, **Troubleshooting**, provides step-by-step procedures to isolate problems and lists possible causes.

Chapter 5, **Service**, presents step-by-step procedures to perform service and parts replacement routines.

LC20 Chromatography Enclosure

Appendix A **Specifications** contains the LC20 specifications.

Appendix B, **Installation**, describes the installation and interface necessary to place the LC20 into operation.

1.3 Product Safety Information

This instrument was designed in conformance with the safety requirements set forth in IEC 1010 *Safety Requirements for Electrical Equipment for Measurement, Control, and Laboratory Use*.

Section of this manual are flagged with key words and symbols to denote the nature of potential hazards. These safety directives apply to all operators and service personnel.

The following safety reference symbols are marked in the instrument and this manual where necessary to alert the operator.



Indicates a potential hazard to the operator, or damage to the instrument or other property.
Example: Overtightening valve bolts may break them off.

2 • Description

2.1	Overview	2-3
2.2	Front Panel	2-3
2.2.1	Rheodyne Injection Valve	2-3
2.3	Interior Layout	2-4
2.3.1	Component Panel	2-5
2.3.2	Rheodyne Injection Valve	2-6
2.3.3	Self-Regenerating Suppressor	2-7
2.3.4	Leak Sensor	2-7
2.3.5	Separator Columns	2-7
2.3.6	Guard Columns	2-7
2.3.7	Column Select Valve	2-8
2.3.8	Detector Cells	2-11
2.3.9	DS3 Detection Stabilizer (Optional)	2-11
2.4	Rear Panel	2-12
2.4.1	Cell Cables	2-13
2.4.2	Waste Line	2-13
2.4.3	Solenoid Interface	2-13

LC20 Chromatography Enclosure

2 • Description

2.1 Overview

Eluent from the gradient pump enters the Rheodyne injection valve port inside the enclosure. From the injection valve, eluent and sample flow through the guard column (if used), the separator column, the suppressor or other post-column device, and finally through the detector cells.

The LC20 may be configured for optional dual-channel operation. It will then include a second Rheodyne injection valve and component panel. There is enough tubing in the LC20 Ship Kit (P/N 046300) to plumb two systems.

The LC20 does not require power. Internal components are operated by the GP40/IP20 pump.

2.2 Front Panel

The front panel of the enclosure is the door. It contains access to one or two Rheodyne injection valves.

2.2.1 Rheodyne Injection Valve

The Rheodyne injection valve is mounted on the component panel in a manner that allows its control knob to extend through the front door for access. If the LC20 is configured as a dual-channel module, a second Rheodyne injection valve will be installed on the left-side component panel and extend through the adjacent port.

2.3 Interior Layout

The interior of the LC20 is an insulated, passive chamber. It contains a slide-out panel for mounting components. Figure 2-1 illustrates the LC20 chassis. See Section B.2.1 for recommended stacking configurations. See Figure 2-2 for an illustration of the slide-out component panel.

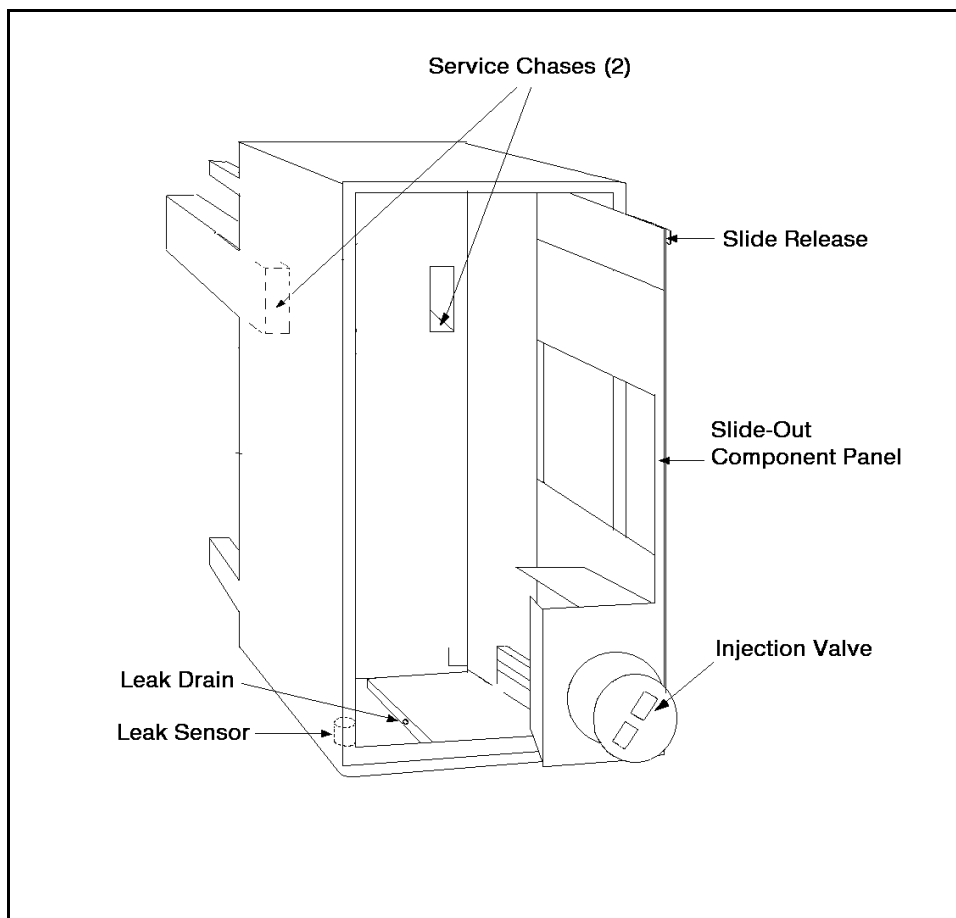

Figure 2-1. LC20 Interior Chassis

2.3.1 Component Panel

Components are mounted on the slide-out panel. The panel on the right side is standard in all LC20 enclosures. When a dual-channel module is ordered, an opposite panel is factory-installed on the left side (see Figure 2-2).

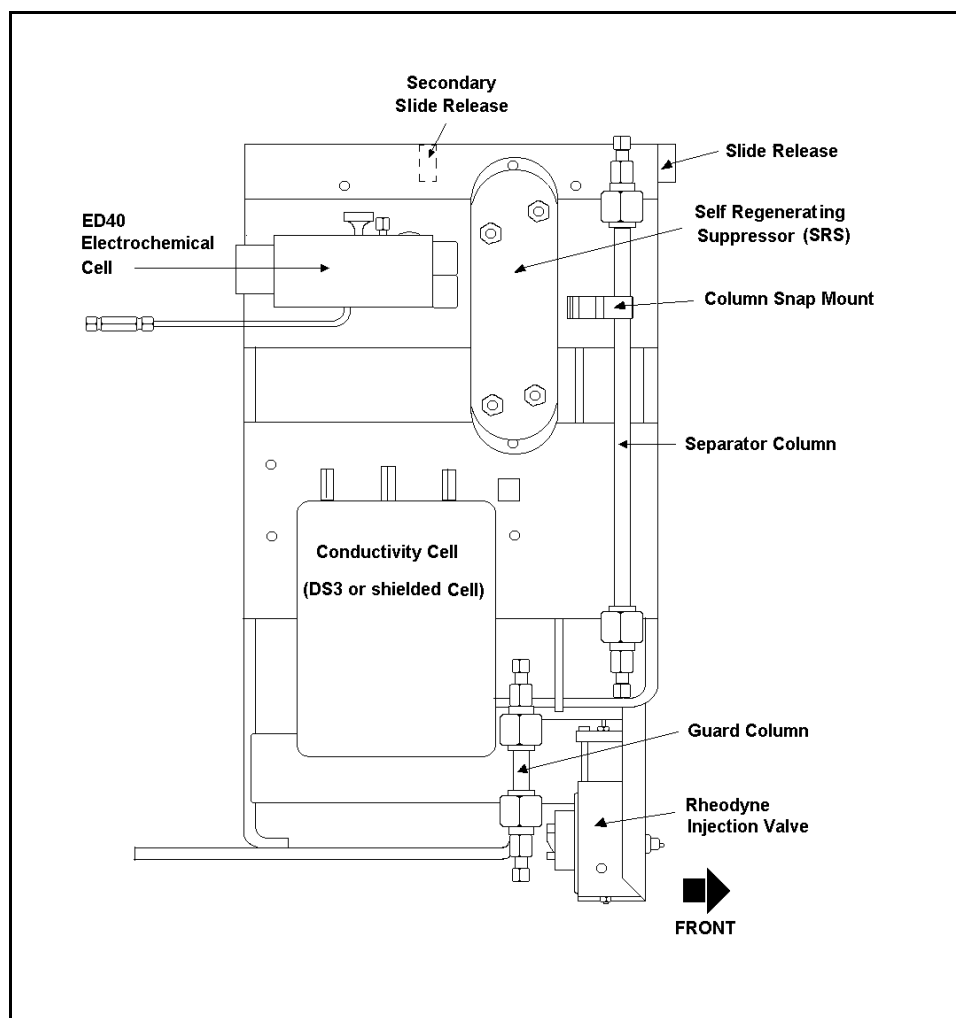

Figure 2-2. Component Panel Layout

The component panel has two slide releases to lock it in a fully closed (in) or open (out) position. Press the slide release at the upper horizontal edge of the panel to release the detent. The panel will lock at about three quarters of its total travel when you pull it out. This prevents it from being pulled entirely out of the tracks and possibly damaging the components. To reinsert the panel, press the second slide release and push it back into its closed position. The fully closed position locks the panel and prevents it from being forced outward by pressure from the various tubing arrangements.

The panel can be pulled completely out by pressing the second slide release and pulling the panel until it clears the top and bottom tracks. Hold the panel securely when it disengages the tracks. To replace the panel, align it with the top and bottom tracks and push inward until it engages the second detent. Press the second slide release and push the panel to its closed and locked position.

Various component arrangements are made possible by multiple mounting holes and slots. The configuration shown here is only one of many offered by the enclosure.

2.3.2 Rheodyne Injection Valve

The Rheodyne injection valve is mounted at the bottom of the component panel. Its control knob extends through the door to allow manual operation with the door closed. The valve has two operating positions: **INJECT** and **LOAD**.

The injection valve is a low-volume, metal-free, 35 MPa (5000 psi) rotary injection valve. It accommodates syringe injections or pressurized sample loading.

The Rheodyne injection valve is equipped with a microswitch for detection of the valve position. The microswitch can be wired to a module that can process the signal to verify the position of the valve.

The LC20 Ship Kit includes two accessories for the Rheodyne injection valves: a 25 µL gas-tight syringe (P/N 041389) and a 25 µL sample loop (P/N 042857). For more information about the valve, including important operating precautions, refer to the *Rheodyne Valve Operator's Manual* (Document No. 034468), included in the LC20 Ship Kit.

2.3.3 Self-Regenerating Suppressor

The Self-Regenerating Suppressor (SRS™) is held in place by a special support plate. Align the two slots on the bottom of the SRS case with the tabs on the support plate. Press *in* and then *down* to lock the SRS in place. Pull *up* and then *out* to remove (see Figure B-8 in Appendix B).

2.3.4 Leak Sensor

This sensor detects leaks and spills in the bottom of the enclosure, and generates a signal when a leak occurs. The sensor is located at the lower front corner of the left wall in the bottom tray. Its cable exits through the rear service chase, and must be connected to the GP40 pump.

2.3.5 Separator Columns

The column mount near the front of the component panel can accommodate up to two separator columns. The column mount supports 4-mm columns on one side and 2-mm columns on the other. The column mount can be removed by pressing on each side of its mounting tab and pulling away from the slot in the panel. You can then reverse it and press it back into the panel to change column size and maintain the columns at the outer position (see Figure B-7 in Appendix B).

2.3.6 Guard Columns

The smaller guard columns (if used) are held in place by the tubing below the separator columns.

2.3.7 Column Select Valve

The column select valve (P/N 044858), when included, will be supported on the component panel by a mounting plate. The column select valve is controlled by the pump through a pair of air solenoids on the back of the LC20.

The column select valve is not normally plumbed into the system. However, enough tubing is provided in the LC20 Ship Kit to plumb up to two column select valves into two systems. When plumbed, the optional 28 MKa (4000 psi) column select valve directs the flow of eluent and sample from the Rheodyne injection valve to either column A or B. The column select valve can alternatively be used to switch in and out a separator column.

The column select valve is actuated by a pair of solenoids mounted on the rear panel, which will be included only when the column select valve is installed. The solenoids are electrically connected to and controlled by the GP40 or IP20 pump. Refer to the pump manual for operating instructions.

Figure 2-3 shows the assembly of the column select valve.

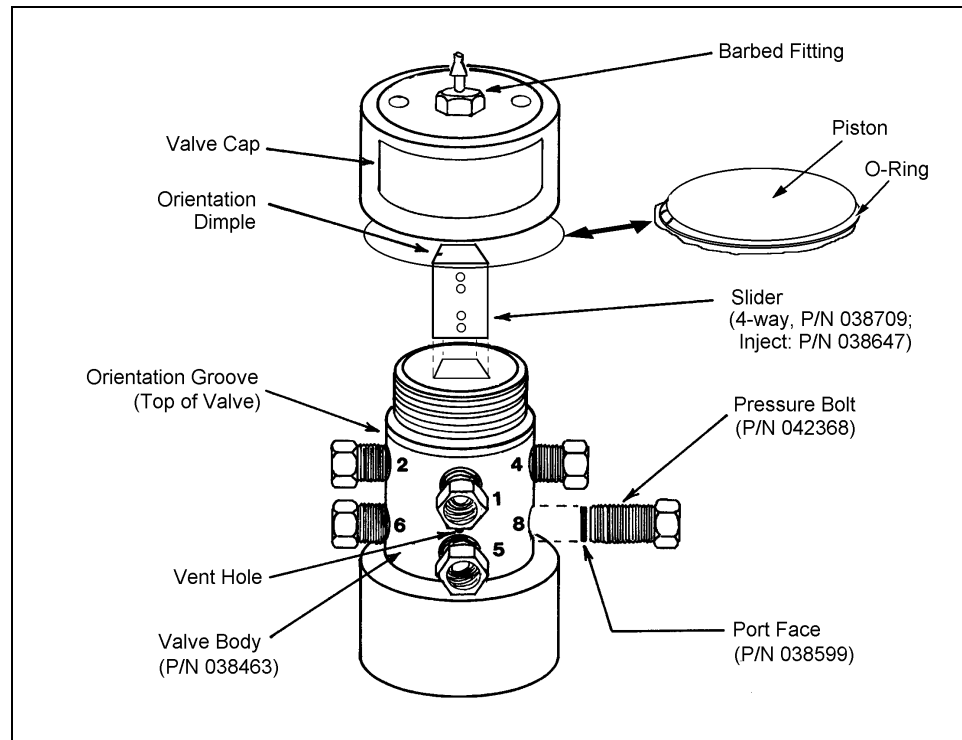

Figure 2-3. Column Select Valve

The groove around the valve body indicates the top of the valve. The ports are numbered clockwise around the valve body. The small vent hole is between ports 1 and 5. Pressure bolts provide an intermediate connection between the valve slider and all tube fittings. **These bolts must be tightened evenly to provide uniform sealing pressure against the valve slider and ensure leak-free operation.** For valve maintenance information, refer to the *Installation and Maintenance of the Dionex High Pressure Valve* (Document No. 032678).

LC20 Chromatography Enclosure

The valve is operated by air pressure pushing against pistons inside the valve cap. The piston pushes a slider up and down inside the valve body. Applying pressure to the top piston pushes the slider down; applying pressure to the bottom piston pushes the slider up. The slider connects the valve ports as follows (see Figure 2-4).:

Switch in OFF position, selecting column A (slider down):

1 → 4 and 2 → 3,
5 → 8 and 6 → 7

Switch in ON position, selecting column B (slider up):

1 → 2 and 3 → 4,
5 → 6 and 7 → 8

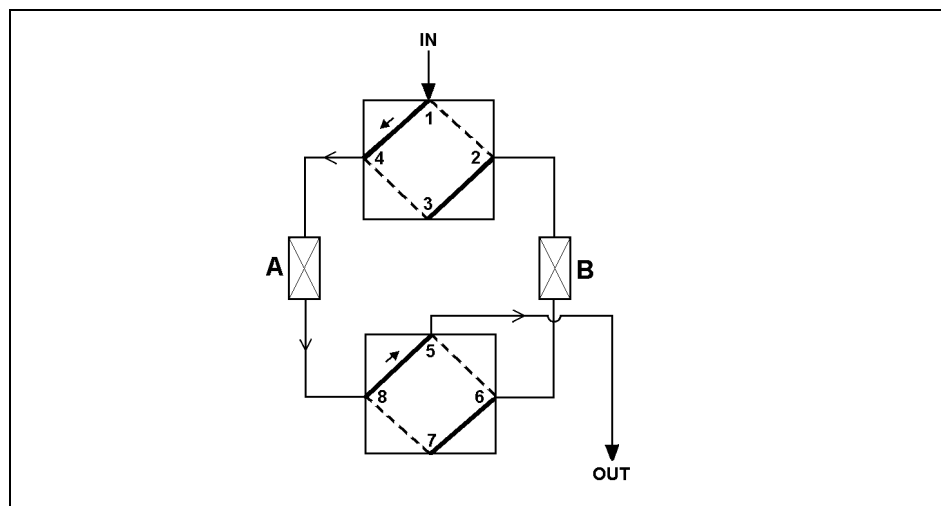

Figure 2-4. Column Select Valve Slider Connections

The valve is tested to operate leak-free at 28 MPa (4000 psi). After testing, the valve pressure bolts are loosened to reduce stress on critical parts during storage. Before shipment, the pressure bolts are tightened to provide leak-free operation at pressures up to 17 MPa (2500 psi) or 90 in-oz torque. If you

need to operate at higher pressures (up to 28 MPa, or 4000 psi), first torque the bolts to 128 in-oz. If the valve is to be unused for more than two days, reduce the torque on the bolts to 90 in-oz while installing or removing the fittings. Use a wrench on the valve pressure bolt to prevent it from turning while loosening the fitting. Refer to *Installation and Maintenance of the Dionex High-Pressure Valve* (Document No. 032678) for additional information.

2.3.8 Detector Cells

Detector cells for the CD20 Conductivity Detector or the ED40 Electrochemical Detector are mounted on the component panel. Their cables exit through one of the service chases on the rear panel.

2.3.9 DS3 Detection Stabilizer (Optional)

The DS3 improves baseline stability by damping fluctuations in temperature, thus improving detection at trace levels. Refer to the *DS3 Detection Stabilizer Installation Instructions* (Document No. 034850).

LC20 Chromatography Enclosure

2.4 Rear Panel

The rear panel provides installation space for air and valve connectors (see Figure 2-5).

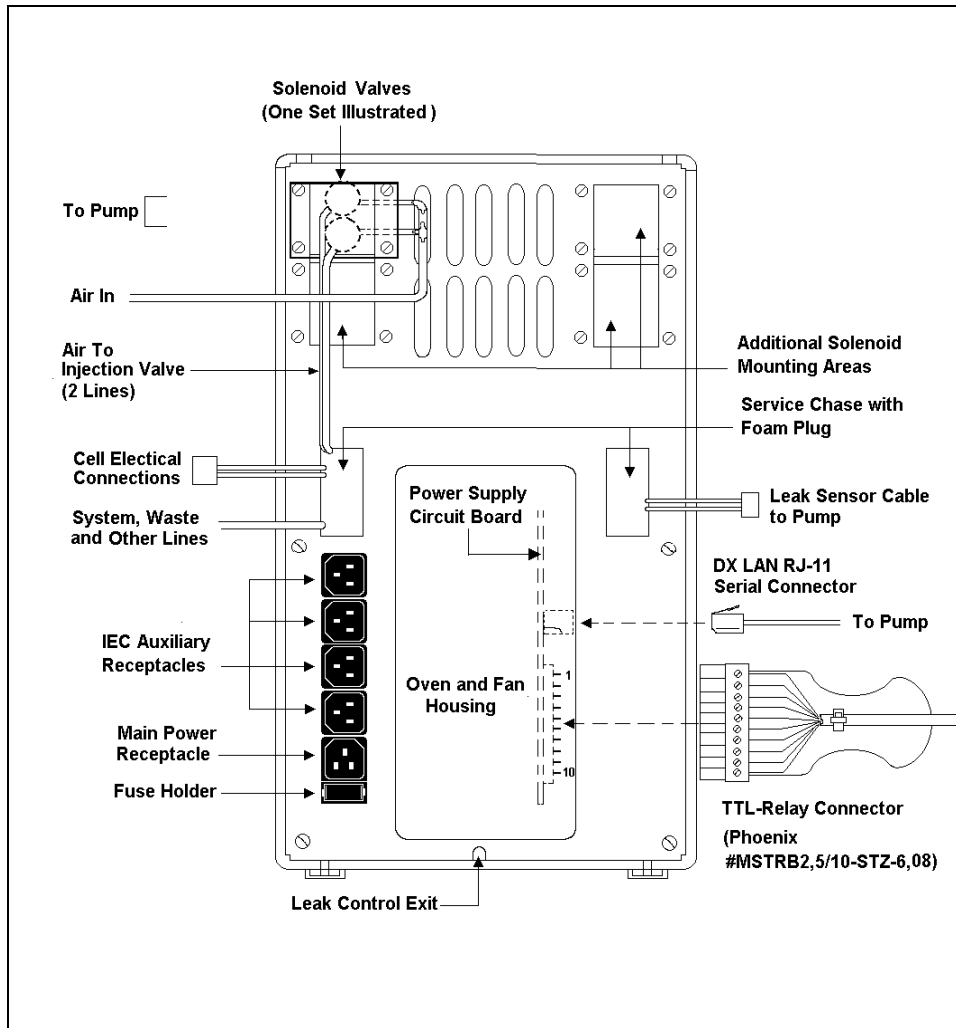

Figure 2-5. LC20 Rear Panel

2.4.1 Cell Cables

The cables inside the LC20, which connect the detector cell to the CD20 Conductivity Detector or the ED40 Electrochemical Detector normally exit through service chase in the rear panel (see Figure 2-5).

2.4.2 Waste Line

The cell and suppressor waste lines from inside the LC20 normally exit through the service chase in the rear panel (see Figure 2-5). The injection valve waste lines should exit through the lower side slots of the enclosure.

2.4.3 Solenoid Interface

The air-actuated solenoid valves used to control the injection valve and the column select valves (if installed) are controlled directly by the pump. The solenoids are installed as pairs; one pair is shown in Figure 2-5.

Refer to the GP40 Gradient Pump or IP20 Isocratic Pump manual for connection details.

LC20 Chromatography Enclosure

3 • Operation and Maintenance

3.1	Routine Operation	3-3
3.1.1	Sample Loading	3-4
3.2	Shutdown	3-7
3.3	Routine Maintenance	3-7

LC20 Chromatography Enclosure

3 • Operation and Maintenance

3.1 Routine Operation

Inside the Rheodyne injection valve, eluent flows through one of two paths depending on the position of the injection valve knob (see Figure 3-6).

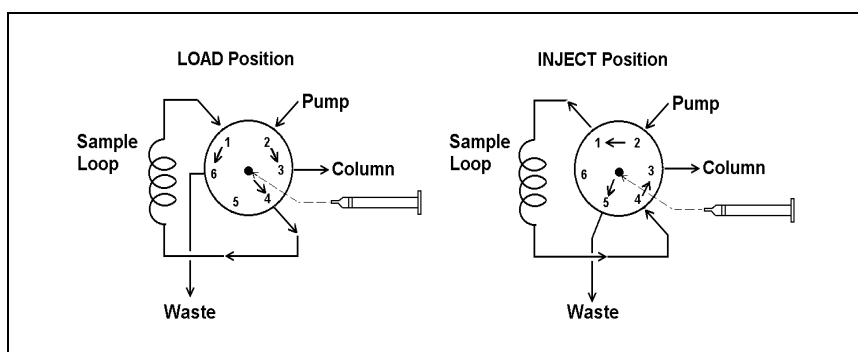

Figure 3-6. Injection Valve Schematic

In the **LOAD** position, eluent flows in from the pump and out to the column without entering the sample loop. Sample flows from the syringe into the valve and through the sample loop, and excess sample flows out to waste.

In the **INJECT** position, eluent flows in from the pump, through the sample loop, and out to the column (carrying the contents of the sample loop with it).

3.1.1 Sample Loading

The Rheodyne injection valve may be filled completely or partially. These techniques differ in accuracy, precision, and the amount of sample required. Refer to the Rheodyne valve *Operating Instructions* included in the LC20 Ship Kit before selecting a method for your application.

Before filling the injection valve sample loop, set the Rheodyne injection valve knob to **LOAD** (see Figure 3-6)

There are four methods for plumbing the Rheodyne valve sample loop:



When inserting needles into the needle port, use only 0.028-inch OD (22 gauge) x 2-in. long needles with 90 degree point style (square end). Using the incorrect needle size can damage the injector.

1. ***Direct injection into the valve:*** Set the injection valve to its **LOAD** position. Insert the syringe into the needle port on the injection valve (see Figure 3-6). Overfill the sample loop with several sample loop volumes. Excess sample will flow out through the waste line. Leave the syringe in the needle port until the injection valve knob is turned to **INJECT**.
2. ***Drawing sample through the waste line:*** Place the injection valve into its **LOAD** position. Insert the syringe into the needle port on the Rheodyne valve, place the valve waste line (port #6) into the sample container (see Figure 3-7). Draw sample into the loop through the injection valve waste line. No sample will come into contact with the metal needle of the loading syringe. Remove the sample from the sample container. Leave the syringe in the needle port until the injection valve knob has been switched to **INJECT**.

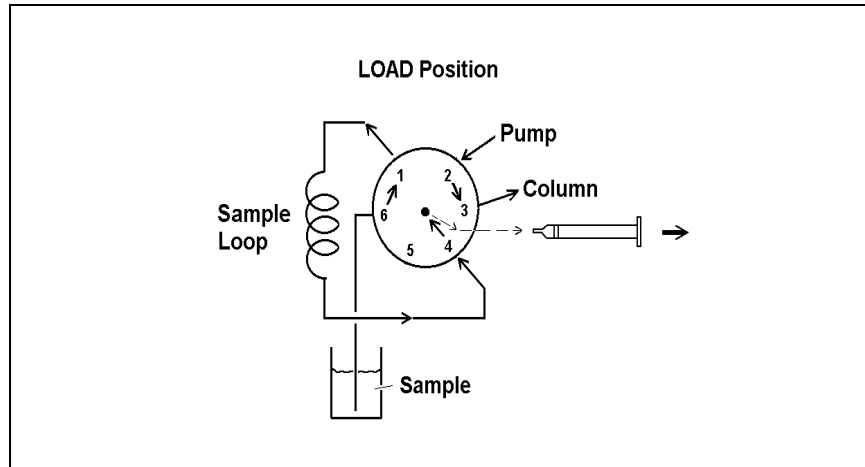

Figure 3-7. Drawing Sample

LC20 Chromatography Enclosure

3. **Loading sample through the waste line:** To avoid the possible outgassing effects of using suction to draw the sample through the waste line, connect a luer fitting and sample-filled syringe in the end of the waste line. Connect the other end of the waste line into injection valve port #6. Place the valve in its **LOAD** position. Insert the needle adaptor shipped with the Rheodyne valve into the needle port. Push sample through the waste line. Waste will exit the valve through the needle adaptor. No sample to be analyzed will come into contact with the metal needle of the needle adaptor (see Figure 3-8).

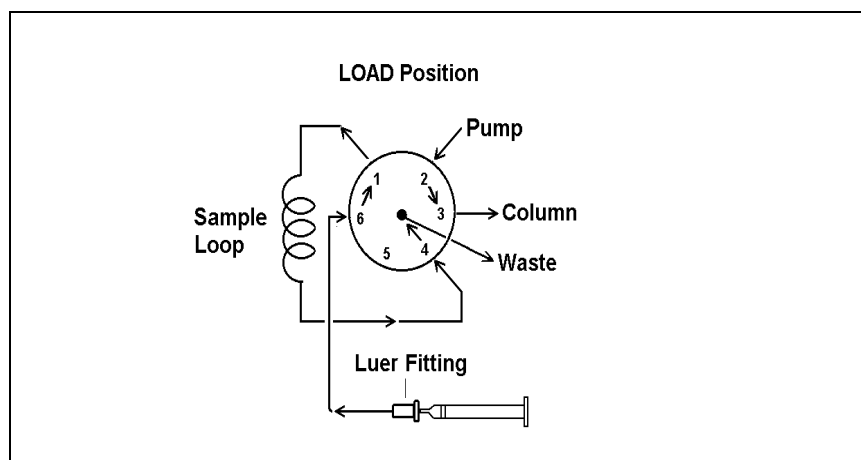

Figure 3-8. Loading Sample

4. **Loading from an automated sampler:** See the autosampler operator's manual for instructions.

3.2 Shutdown

If the LC20 will not be used for more than three days and if the column select valve is torqued for high pressure, reduce the torque on the pressure bolts to 90 in-oz to prevent possible damage to the valve.

If other modules are connected to the rear panel power strip, make sure the front panel door is fully closed. Press the power actuator switch on the front panel to shut off power to other modules. The power actuator rod leading the power switch at the rear of the module will not operate if the door is open.

3.3 Routine Maintenance

- Periodically check for leaks or spills inside the LC20. Locate and repair leaks and clean up spills. Rinse all dried eluents (especially when they include salt solutions) or reagents off system components with deionized water or, in the case of spilled ninhydrin, with isopropyl alcohol.
- Periodically check all air and liquid lines for crimping. Move or reroute pinched lines; replace damaged lines.

LC20 Chromatography Enclosure

4 • Troubleshooting

4.1	Liquid Leaks	4-3
4.2	Excessive System Backpressure	4-4
4.3	Inoperative Column Select Valve	4-5
4.4	Column Select Valve Air Leaks	4-5
4.5	Peak Ghosting	4-6
4.6	Non-Reproducible Peak Height or Retention Time	4-6
4.7	Abnormal Retention Time or Selectivity	4-6

LC20 Chromatography Enclosure

4 • Troubleshooting

Use this troubleshooting guide to isolate and solve problems that may occur while using the LC20. If there is more than one possible cause, read the potential sources of the problem to determine which may be the most applicable. If the problem persists, call the nearest Dionex Regional Office.

For troubleshooting procedures specific to the Rheodyne injection valve, refer to the *Rheodyne Valve Operator's Manual* (Document No. 034468).

4.1 Liquid Leaks

- **Leaking fitting.**

Locate the source of the leak. Make sure all liquid line connections are tight:

1. If the connections are made with Dionex ferrule fittings, see *Installation of Dionex Ferrule Fittings* (Document No. 034213) for instructions.
2. If the column select valve is plumbed into the system, remove the valve from its mounting clip to improve access to all valve ports. Use a wrench on the valve pressure bolt to prevent it from turning while tightening the fitting.

- **Broken liquid line.**

Replace the ferrule or replace the tubing.

- **Blocked or improperly installed waste line.**

Make sure the waste lines from the valves and cells are not crimped or otherwise blocked. Also make sure they are not elevated at any point after they exit the module.

- **Pressure bolt(s) on column switching valve are too loose.**

Follow the procedure below to tighten the pressure bolts:

1. Turn off the liquid flow.
2. Tighten each pressure bolt fingertight, then use an open-end wrench to tighten an additional one-eighth turn.

NOTE

All eight pressure bolts must be evenly tightened against the slider for optimum leak-free operation.

3. Turn on the liquid flow evenly and check for leaks. Tighten pressure bolts further if leaks appear.

NOTE

Use a torque wrench to evenly tighten pressure bolts for optimum leak-free operation. Refer to *Installation and Maintenance of the Dionex Inert High Pressure Valve* (Document No. 032678) for torque requirements.

- **A column select valve port is scratched.**

Replace the port face.

4.2 Excessive System Backpressure

- **Restriction in the hydraulic system.**

1. Check all liquid lines and valves for crimping or blockage. Make sure ferrule fittings are not overtightened into Tefzel tubing. Refer to *Installation of Dionex Ferrule Fittings* (Document No. 034213) for details.
2. Verify that valves are being fully activated (not between positions).

- **Flow rate through the columns is too high.**

Reduce the flow rate.

- **Clogged column bed supports.**

Replace the bed supports as instructed in the column manual.

- **Columns are contaminated.**

Clean the columns (see *Column Rejuvenation Procedures*, Technical Note 2R, Document No. 032036).

4.3 Inoperative Column Select Valve

- **Air is not reaching the valve.**

Check that the air supply is turned on and is supplying 550 to 820 KPa (80 to 120 psi).

- **Air tubing harness is crimped or blocked.**

Check the air tubing for blockage. Remove and replace any blocked tubing. Reposition crimped or pinched tubes.

- **Air leak.**

Air leaks are usually audible; isolate and eliminate leaks.

- **Valve is incorrectly plumbed.**

Check that the system is correctly plumbed. Re-plumb the system if necessary.

- **Pressure bolts on the column select valve are too tight.**

Follow the procedure in Section 4.1 to loosen the pressure bolts if the column select valve is plumbed into the system:

4.4 Column Select Valve Air Leaks

- **Air leak.**

Air leaks are usually audible and frequently cause excessive cylinder gas/air consumption. Locate and repair the leak.

4.5 Peak Ghosting

Ghosting is the appearance of extraneous peaks in a chromatogram. These may be late-eluting peaks from a previous injection or result from a contaminated valve or a poor sample loading technique. These peaks may co-elute with peaks of interest, resulting in non-reproducible peak heights.

- **Insufficient time between sample injections.**

Wait until the previous sample has been completely eluted before making another injection.

- **Insufficient flush between samples.**

Flush the sample loop with at least 10 loop volumes of deionized water or sample between sample injections.

4.6 Non-Reproducible Peak Height or Retention Time

- **Column overloading.**

1. Change to a sample loop with a smaller volume.
2. Dilute the sample.

- **Liquid leaks.**

Locate and eliminate the leaks.

Also see “Peak ghosting” in Section 4.5 above.

4.7 Abnormal Retention Time or Selectivity

- **System is not equilibrated following an eluent change.**

Allow the system to equilibrate with at least 20 column volumes of eluent (for example, 30 minutes at 2.0 mL/min for 4 mm anion separator columns).

- **Flow rate through system is incorrect.**

1. Check that the correct flow rate is selected.

2. Locate and eliminate any liquid leaks.

- **Contaminated or incorrect eluent.**

Remake the eluent using reagent grade chemicals and ASTM filtered Type I (18 megohms or 1 μ S) grade deionized water.

- **Contaminated or degraded sample.**

Take appropriate precautions when preparing and storing samples to prevent contamination and degradation.

- **Column is contaminated.**

1. Clean the column (see *Column Rejuvenation Procedures*, Technical Note 2R, Document No. 032036).
2. If cleaning is unsuccessful, replace the column.

LC20 Chromatography Enclosure

5 • Service

5.1	Introduction	5-3
5.2	Tube Fitting Installation	5-3
5.3	Restriction in the Hydraulic System	5-4
5.4	Injection or Column Select Valve Liquid Leaks	5-4
5.5	Column Select Valve Air Leaks	5-5
5.6	Cleaning the Column Select Valve Slider	5-6
5.7	Replacing the Column Select Valve Port Face	5-9
5.8	Servicing the Rheodyne Injection Valve	5-9

LC20 Chromatography Enclosure

5.1 Introduction

This section describes service and repair procedures for the LC20. These services are required rarely, but some wear of the fittings and tubing is to be expected during the life of the enclosure. Before repairing or replacing any part, refer to Chapter 4 to isolate the source of the problem. For service and maintenance procedures for the Rheodyne injection valve, refer to the Rheodyne manual supplied in the LC20 Ship Kit.

When ordering replacement parts, please include the model and serial number of your LC20. If possible, also provide the part numbers and, where applicable, the revision number of the items you are ordering.

5.2 Tube Fitting Installation

The LC20 is plumbed with Dionex 10-32 ferrule fittings. PEEK tubing is recommended for use throughout the system. However, ThermoFlare tubing may be installed where pressures are below 7 MPa (1000 psi); this includes waste lines, tubing from an autosampler to the Rheodyne valve injection port, or tubing from the separator column to the suppressor. Use 1.6-mm (0.063-in) ID Teflon tubing for regenerant lines for both the 2-mm and 4-mm suppressors.

For instructions on how to install ferrule fittings on PEEK or Tefzel tubing, refer to *Installation of Dionex Ferrule Fittings* (Document No. 034213), provided in the LC20 Ship Kit.

5.3 Restriction in the Hydraulic System

A restriction in the hydraulic system will cause excessive system backpressure.

1. Begin pumping eluent through the system (including the columns) at the flow rate normally used.
2. Follow the appropriate hydraulic schematic (see Figures B-4 through B-6) and work backward through the system, beginning at the cell exit. One at a time, loosen each fitting and observe the pressure. The connection at which the pressure drops indicates the point of point of restriction.
3. Remove the restriction either by back flushing or by replacing the section of tubing.
4. If the restriction is caused by the column select valve, disassemble the valve and clean the slider (see Section Figure 2-4. Column Select Valve Slider Connections)

5.4 Injection or Column Select Valve Liquid Leaks

A poor seal between the ferrule sealing surface and the valve pressure bolt or between the port face and the valve slider may cause the column select valve to leak (see Figure 2-3). The flow rate through the system may be low, producing chromatograms with longer than normal retention times and poor reproducibility.

1. Tighten any loose fittings fingertight, then an additional one-eighth turn. Tighten further only if a leak continues.



DO NOT OVERTIGHTEN. Use an open end wrench to hold the valve pressure bolts to prevent them from turning when tightening connections to the valves.

2. If tightening the fitting does not stop the leak, disconnect the fitting from the valve. Occasionally, fittings stop leaking if simply disconnected and then immediately reconnected. If the leak continues, install a short length of tubing, with fittings, between the pressure bolt and the suspect fitting. Connect the fitting to the tubing with a union. A leaking fitting will also leak inside the union. If necessary, replace the fitting. **If you replace the fitting, also replace the ferrule.**

NOTE

When connecting or disconnecting fittings from the valve pressure bolts, use a wrench to hold the bolt and prevent it from turning.

3. Make sure all valve pressure bolts are evenly tightened. Refer to *Installation and Maintenance of the Dionex Inert High-Pressure Valve* (Document No. 032678) for the torque requirements. **Use caution as overtightening may break off the bolt in the valve body.**
4. If tightening the pressure bolts does not stop the leak, refer to Section 5.7 for instructions to replace the port face.

5.5 Column Select Valve Air Leaks

An air leak around the valve piston or cap results in excessive air consumption and may cause the valve to operate sluggishly or not at all.

1. Remove the column switching valve from its mounting clip.
2. Make sure that the top and bottom caps are tight. If necessary, tighten them fingertight.
3. If the leak continues, determine which end of the valve leaks by activating the corresponding switch. Air will escape through the vent hole when the leaking end is pressurized.
4. Disconnect the air line from the leaking cap. If necessary, use the valve switch to turn off the air through the disconnected line.

LC20 Chromatography Enclosure

5. Unscrew the leaking cap from the valve body (Figure 2-3). Inspect the cap O-ring for cracks and replace if necessary (P/N 038650).
6. Press the disconnected air line (Step 4) against the small vent hole between ports 1 and 5. Activate the valve switch to apply air pressure against the slider. The piston will pop out of the valve body.
7. Inspect the piston O-ring for cracks and replace if necessary (P/N 038651).
8. Carefully lubricate the piston O-ring with a small amount of silicone grease.



CAUTION

Use the grease sparingly. Excess grease may contaminate the eluent.

9. Press the piston back into the valve body.
10. Make sure that the cap O-ring is inside the cap. Screw the cap back onto the valve body. Tighten it only fingertight.
11. Reconnect the air line to the valve.

5.6 Cleaning the Column Select Valve Slider



CAUTION

A dirty or plugged valve slider causes excessive system backpressure and may cause poor chromatographic performance.

1. Turn off the pump and the eluent selector valves.
2. Remove the plugged valve from its mounting clip (see Figure 2-3)
3. Disconnect the air line from one cap. If necessary, use the valve switch to turn off the air through the disconnected line.

4. Unscrew one cap from the valve body. Be careful not to lose the cap O-ring.
5. Press the disconnected air line (Step 3) against the small vent hole between ports 1 and 5. Activate the valve switch to apply air pressure against the slider. The piston will pop out of the valve body.
6. Turn off the air supply.
7. Carefully loosen each of the pressure bolts one-eighth turn to disengage the port faces from the slider. Do not loosen any further.
8. Remove the other cap. Push on the slider to force the other piston out of the valve body.
9. Carefully push the slider out of the valve body with a blunt rod.
10. Inspect the slider surface. If there are scratches in the surface, replace the slider (P/N 038709).
11. Place the slider in a small container of deionized water or methanol. Sonicate or agitate vigorously for several minutes.
12. Rinse the slider with deionized water. Blow any water out of the holes and inspect them for blockage. Use a fine piece of wire (0.025 in) to dislodge any remaining blockage. Be careful not to scratch the slider surface. If the blockage cannot be removed, replace the slider.
13. Push the slider back into the valve body. Orient the dimple on the top of the slider between ports 1 and 2 of the valve body (see Figure 2-3).

The valve operates properly only if the slider is correctly oriented in the valve body. The groove around the valve body indicates the top of the valve body. The small vent hole is between ports 1 and 5. The ports are numbered clockwise from the top around the valve body. The slider connects the ports as follows:

Switch in OFF or LOAD position (slider down):

1 → 4 and 2 → 3
5 → 8 and 6 → 7

Switch in ON or INJECT position (slider up):

1 → 2 and 3 → 4
5 → 6 and 7 → 8

14. Inspect the piston O-rings (P/N 038651) and replace them if necessary.
15. Carefully lubricate the piston O-rings with a small amount of silicone grease and reassemble the valve (see Section 5.5 for instructions to correct Column Select Valve air leaks).
16. Tighten each pressure bolt fingertight, then use an open end wrench to tighten an additional one-eighth turn.

For optimal leak-free operation at 28 MPa (4000 psi), all eight pressure bolts must be evenly tightened against the slider (128 in-oz). A special torque wrench kit (P/N 038943) is available from Dionex.

17. Turn on the liquid flow and check for leaks. Tighten the pressure bolts further if leaks appear. **Use caution as overtightening may break off the bolt in the valve body.**
18. If cleaning the valve slider does not eliminate the backpressure problem, see the next section for instructions to replace the port face.

5.7 Replacing the Column Select Valve Port Face

A scratched port face may cause a leak around the pressure bolt. A plugged port face will cause excessive system backpressure and may cause poor chromatographic performance.

1. Turn off the liquid flow.
2. Remove the valve from its mounting clip.

3. Disconnect the tube fitting from the pressure bolt that shows evidence of leaking, then unscrew the pressure bolt from the valve body.
4. Inspect the port face. If it is scratched or plugged, carefully pry it out of the pressure bolt, using the extractor tool (P/N 038930) designed for this. Press a new port face (P/N 038599) into the pressure bolt. **Be careful to not scratch the sealing surfaces!**
5. Screw the pressure bolt into the valve body. Tighten each pressure bolt fingertight, then use an open end wrench to tighten an additional one-eighth turn.

For optimal leak-free operation at 28 MPa (4000 psi), all eight pressure bolts must be evenly tightened against the slider (128 in-oz). A special torque wrench kit (P/N 038943) is available from Dionex.

6. Turn on the liquid flow and check for leaks. Tighten pressure bolts further if leaks appear.

For optimal leak-free operation, a torque wrench can be used to evenly tighten pressure bolts. Refer to *Installation and Maintenance of the Dionex Inert High-Pressure Valve* (Document No. 032678) for torque requirements. **Use caution as overtightening may break off the bolt in the valve body.**

7. Reconnect the tube fitting to the pressure bolt. Use a wrench to prevent the pressure bolt from turning while tightening the fitting. Tighten the fitting fingertight, then an additional one-eighth turn. Tighten further only if leaks appear.

5.8 Servicing the Rheodyne Injection Valve

The Rheodyne injection valve requires infrequent servicing. See the *Rheodyne Valve Operator's Manual* (Document No. 034468) for specific maintenance and service requirements. For major disassembly, contact the nearest Dionex Regional Office for assistance.

LC20 Chromatography Enclosure

A • Specifications

- A.1 Environmental A-3
- A.2 Physical A-3
- A.3 Hydraulics A-3
- A.4 Insulation A-4

LC20 Chromatography Enclosure

A • Specifications

A.1 Environmental

Ambient Temperature:	4 °C to 75 °C (40 °F to 167 °F)
Humidity:	5-95% relative (non-condensing)
Air Pressure:	400 to 800 KPa (60 to 120) psi for the Rheodyne injection valve and column select valve; Use laboratory-quality air or regulated compressed air, nitrogen, or helium.
Operating Pressure:	35 MPa (5000 psi) maximum liquid path (tubing, valves, columns, etc.)

A.2 Physical

Dimensions:	50 cm high x 22.5 cm wide x 49 cm deep (20.8 in x 8.9 in x 20.4 in) 6 cm clearance required in back of the module
Weight:	12 kg (25 lbs)

A.3 Hydraulics

Rheodyne Injection Valve:	35 MPa (5000 psi) metal-free or stainless steel rotary valve for low-volume injections.
Column Select Valve:	28 MPa (4000 psi) metal-free column select valve to direct eluent and sample to one of two columns. The column select valve option is installed at the factory but is not plumbed into the system. Tubing to plumb the LC20 for column select applications is included in the LC20 Ship Kit (P/N 046300).

A.4 Insulation

Dampening Dampens outside temperature variations by a factor of
-5 to 10 over 10 minutes
-2 to 4 over 60 minutes

B • Installation

B.1	Facilities Required	B-3
B.2	Installation Instructions	B-4
B.2.1	Stacking Modules	B-4
B.2.2	Waste Lines	B-5
B.2.3	Leak Control	B-6
B.2.4	Liquid Line Connections	B-6
	Injection Valve Connections	B-7
B.2.5	Detector Cells	B-9
	External Cell	B-9
	Internal Cell	B-10
B.2.6	Column Installation	B-12
B.2.7	SRS Installation (Optional)	B-13
B.2.8	Solenoid Valve Connections to the Pump	B-14

LC20 Chromatography Enclosure

B • Installation

B.1 Facilities Required

Appendix A of this manual contains the complete LC20 specifications. The location selected to install the LC20 should also meet the following requirements:

- A sturdy table or work bench with at least 15 cm (6 in) free space behind the module for connections and ventilation. Maximum horizontal slope is 2-cm per lateral meter (0.25-inch per lateral foot).
- Nitrogen, argon, or helium gas cylinder for reservoir pressure.
- As the enclosure does not have temperature control, the environment will affect the enclosure operation. The system should be installed with adequate ventilation and in an environment that provides maximum consistency in ambient temperature and humidity. In general, you should
 - avoid sun and proximity to hot equipment.
 - avoid heavy air drafts and sudden temperature changes
 - not operate the enclosure in condensing atmospheres
 - maintain specified ambient temperatures.

Connect gas/air pressure to the solenoids on the rear panel (see Figure 2-5). The gas/air pressure is routed to the enclosure valves through air valves, which are actuated electrically by the pump. Connect the wiring to the proper connector on the pump according to the plumbing schematics further in this chapter.



To avoid contamination and possible deterioration of the valves, make sure laboratory pneumatic air, if used, is oil-free, dry, and filtered, and maintained within the pressure limits specified above.

B.2 Installation Instructions

A Dionex-trained representative will install the LC20 and other system modules for you. The instructions given here are for your reference. Contact the nearest Dionex Regional Office for assistance if you experience any difficulties during or after installation that are not addressed in this manual.

B.2.1 Stacking Modules

Dionex DX-500 Chromatography System modules are designed to be stacked on top of each other up to a maximum height of four units. The enclosure is three units high and should not be stacked on any other unit. The enclosure should not have more than one single-unit module on top of it, such as a CD20 Conductivity Detector, ED40 Electrochemical Detector, or the EO1 Eluent Organizer (P/N 044125). Figure B-1 illustrates the recommended stacking configuration.

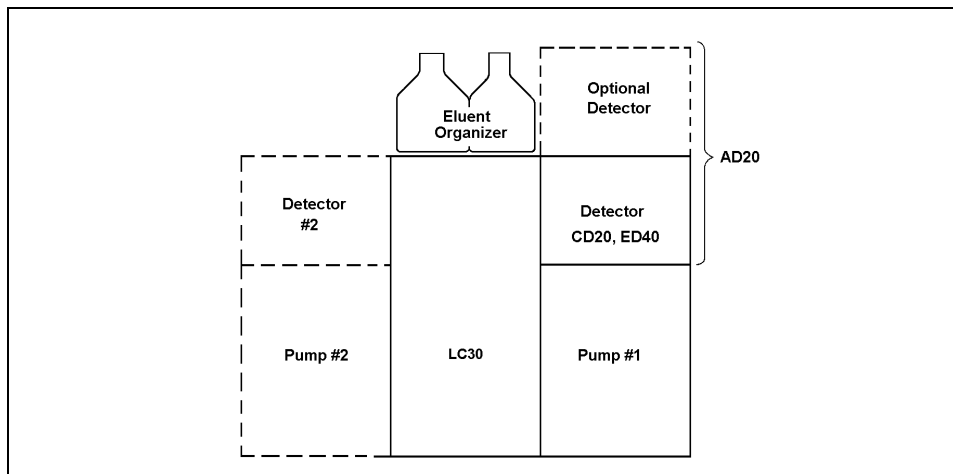

Figure B-1. Recommended Stacking Configuration



Lift the module only from the bottom surface. Do not lift it with the panel doors as this will damage the door hinges.

B.2.2 Waste Lines

Install the piece of 12.5-mm (0.5-in) OD tubing (P/N 035759) over the waste nipple in the lower left corner of the LC20 rear panel (see Figure 2-5). Make sure the opposite end of the line is inserted into a waste container below the level of the enclosure and that it is not bent, pinched, or elevated at any point (see Figure B-2).

Minor leaks do not generally present a serious situation, but they should be thoroughly rinsed with deionized water and dried to prevent salt solutions from crystallizing on the enclosure surfaces.

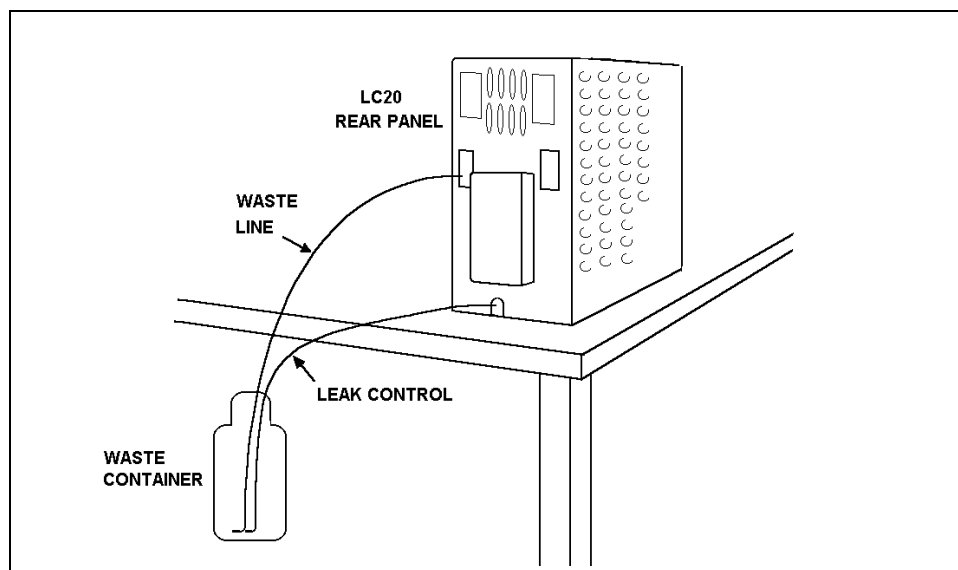

Figure B-2. Waste Lines Installation



**Neutralize acidic and caustic waste before disposal.
Dispose of wastes containing organic solvents in
accordance with local regulations.**

B.2.3 Leak Control

If a leak occurs, waste liquid will accumulate in the bottom of the enclosure. The bottom is slanted to collect the liquid in the trough on the left side. A line at the rear of the trough drains the liquid from the enclosure and into a waste container. A leak detector cell is located on the sidewall of the trough to detect and report any leaks. The output of the sensor should be connected to any module that can process the signal and report it as a fault.

A leak is generally not a serious event. However, all leaks should be stopped and the floor should be dried and rinsed with deionized water to prevent formation of salt crystals.

B.2.4 Liquid Line Connections

The LC20 Ship Kit contains PEEK tubing in three different IDs. After selecting the appropriate tubing size (see below), you will need to cut the tubing to the lengths required to plumb the system. However, before cutting any tubing, be sure that it is long enough to allow servicing the system (e.g., you should be able to open the front door of the LC20 and slide the component panel out of the enclosure to its detent without putting stress on the tubing).

- **For 4-mm column systems:** Use 0.25-mm (0.010-in) ID PEEK tubing (P/N 042690) for connections between system components.
- **For 2-mm column systems:** Use 0.125-mm (0.005-in) ID PEEK tubing (P/N 044221) for connections between system components.
- **For both systems:** Use 0.5-mm (0.020-in) ID PEEK tubing (P/N 042885) for valve waste lines and 0.25-mm (0.010-in) ID PEEK tubing (P/N 042690) for detector cell waste lines.

If preferred, ThermoFlare™ tubing can be installed where pressures are below 7 MPa (1000 psi). This may include

waste lines, tubing from an autosampler to the Rheodyne injection valve port, and tubing from the separator column to the SRS.

The system plumbing depends primarily on the detection mode. Consult the proper fluid schematic in Section B.2.5.

The LC20 is plumbed with Dionex 10-32 ferrule fittings. If you need instructions on how to install ferrule fittings, refer to *Installation of Dionex Ferrule Fittings* (Document No. 034213), provided in the LC20 Ship Kit.

Injection Valve Connections

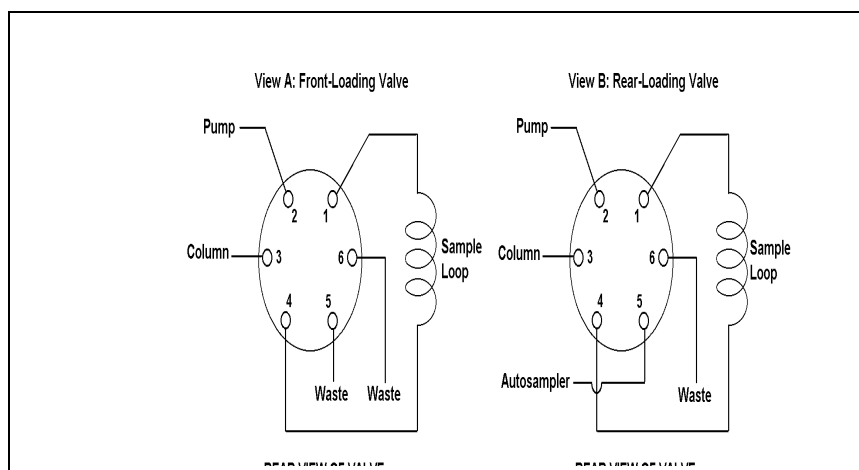

Figure B-3. Injection Valve Ports

1. Connect the eluent line from the pump pressure transducer to port #2 on the Rheodyne injection valve. A label on top of the valve identifies ports #1 and #2. Ports #3 through #6 follow in sequence, with port #6 close to port #1 on the opposite side from port #2 (see Figure B-).
2. Connect a piece of PEEK tubing with ferrule (P/N 043276) and fitting (P/N 043275) to port #3 on the Rheodyne valve.

LC20 Chromatography Enclosure

3. Connect the other end of the tubing to the separator column (or guard column, if installed). Refer also to *Installation of Dionex Ferrule Fittings* (Document No. 034213) included in the LC20 Ship Kit.
4. Connect the 25 μL sample loop (P/N 042857) between ports #1 and #4 of the Rheodyne injection valve. Other sample loop sizes are available, contact the nearest Dionex Regional Office for information.
5. Cut two pieces of tubing for waste lines. Install a ferrule (P/N 043276) and fitting (P/N 043275) on one end of each of the pieces of tubing.
6. Connect the ferrule fitting end of one of the waste lines to port #5 on the Rheodyne valve. Connect the ferrule fitting end of the second waste line to port #6. Route the waste lines out through the chases and place the ends of the lines in a waste container.

B.2.5 Detector Cells

External Cell

When using a detector with a cell external to the LC20 (normally an optical detector), connect the outlet of the separator column or suppressor to the detector cell inlet (see Figure B-4). Route the tubing exiting the separator column or suppressor through one of the side slots on the LC20.

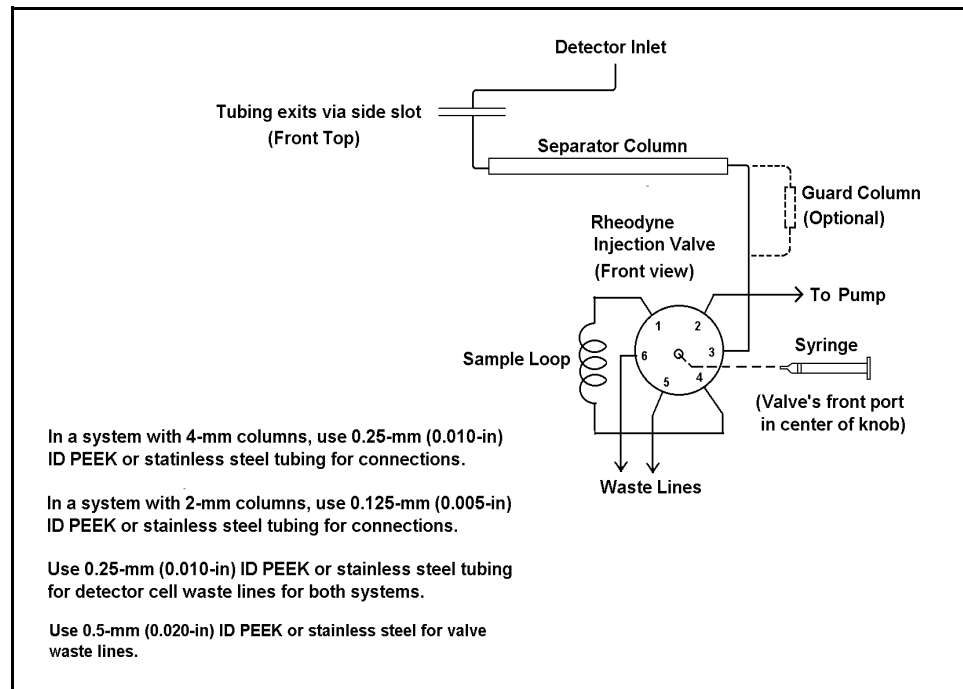

Figure B-4. External Detector Cell Plumbing Schematic

LC20 Chromatography Enclosure

Internal Cell

Refer to the appropriate plumbing schematic in the following series (Figures B-4 through B-6) when installing a cell in the LC20. If the conductivity cell is installed inside the optional DS3 Detection Stabilizer, see the *DS3 Detection Stabilizer Operator's Manual* (Document No. 034850).

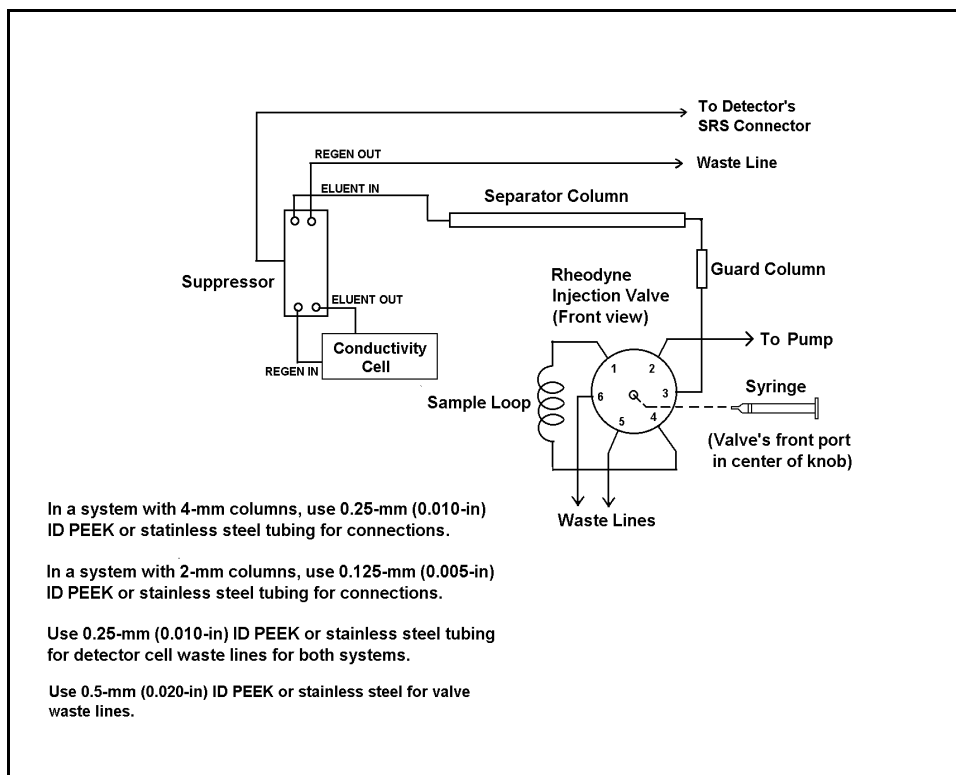

Figure B-5. Conductivity Cell Plumbing Schematic

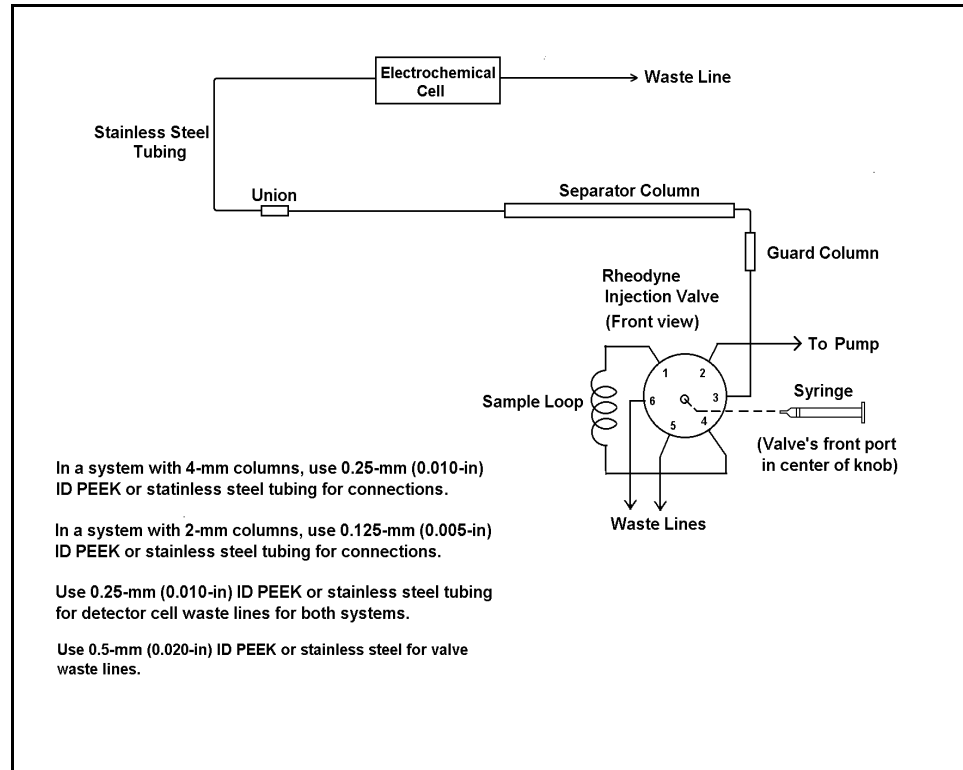

Figure B-6. Electrochemical Cell Plumbing Schematic

B.2.6 Column Installation

The separator columns are purchased separately from the LC20.

1. Before installing the separator columns, pump deionized water through the LC20 at 3 mL/min for 1 to 2 minutes to clear any air from the liquid lines. Activate injection each valve several times to make sure that no air is trapped in the hydraulic system. Trapped air will reduce efficiency.
2. Reduce the flow rate to 2.0 mL/min and verify that the pressure through the system, with no columns installed, is less than 690 KPa (100 psi).
3. Install the separator column mounting clip by inserting it into one of the square holes at the front edge of the component panel (see Figure B-7. If you are using the 4-mm suppressor columns, orient the clip so the larger clips are toward the front. If you are using the 2-mm columns, orient the clip so the smaller clips are nearer the front.

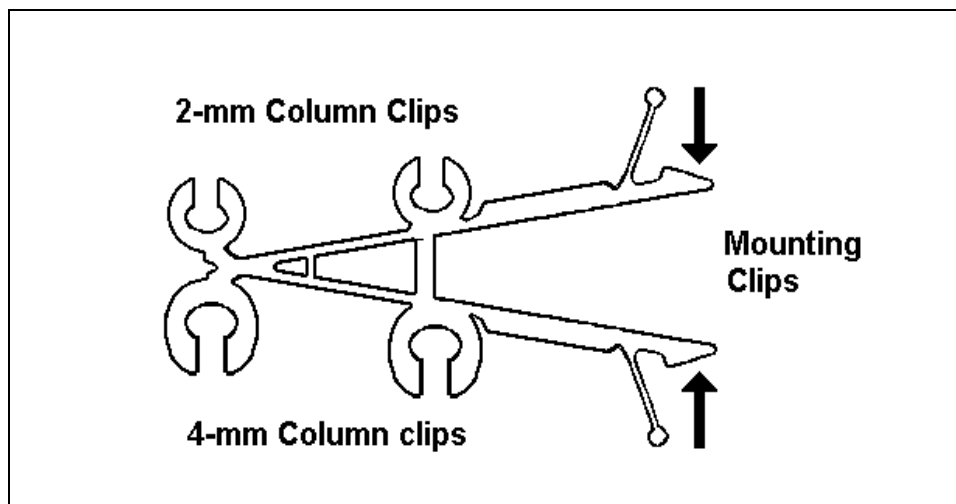

Figure B-7. Separator Column Mounting Clip

4. Each column is accompanied by a manual containing specialized installation and start-up instructions. After consulting your column manual for any special requirements, install the columns in the LC20:
 - a. Remove the end plugs from the separator column and store them in a safe place. You must reinstall the end plugs in the columns before placing the columns in storage.
 - b. Use PEEK tubing with ferrule fittings to connect the inlet of the guard column to the #3 port of the Rheodyne valve.
 - c. Connect the outlet of the guard column to the inlet (bottom) of the separator column.
 - d. For suppressed conductivity detection, connect the outlet (top) of the separator column to the **ELUENT INLET** of the SRS. Otherwise, connect the separator outlet directly to the detector inlet.
5. Snap the separator columns into the column clips on the component panel. See Figure 2-2 for an illustration of the columns mounted in the clips. The guard columns are held in place only by the connecting tubing.

B.2.7 SRS Installation (Optional)

1. For complete SRS technical details, refer to the SRS manual.
2. If you are using an external regenerant:
 - a. Assemble and fill the regenerant reservoir as described in the instructions shipped with the reservoir.
 - b. Locate the 75-mm (30-in) tubing (P/N 035727) in the SRS Ship Kit. Use this tubing to connect the reservoir to the **REGENERANT INLET** of the SRS.
 - c. Adjust the regenerant flow rate as instructed in the SRS manual.

3. Direct the line connected to the SRS **REGENERANT OUTLET** through the service chase and to a waste container.
4. Mount the SRS on the component panel (see Figure B-8). The SRS has a special mounting bracket that can be installed in several positions on the component panel, depending on your application. After mounting the bracket, align the slots on the back of the SRS with the tabs on the mounting bracket. Press *in* and then *down* to lock the SRS in place. Lift *up* and pull *out* to remove the SRS, if necessary.

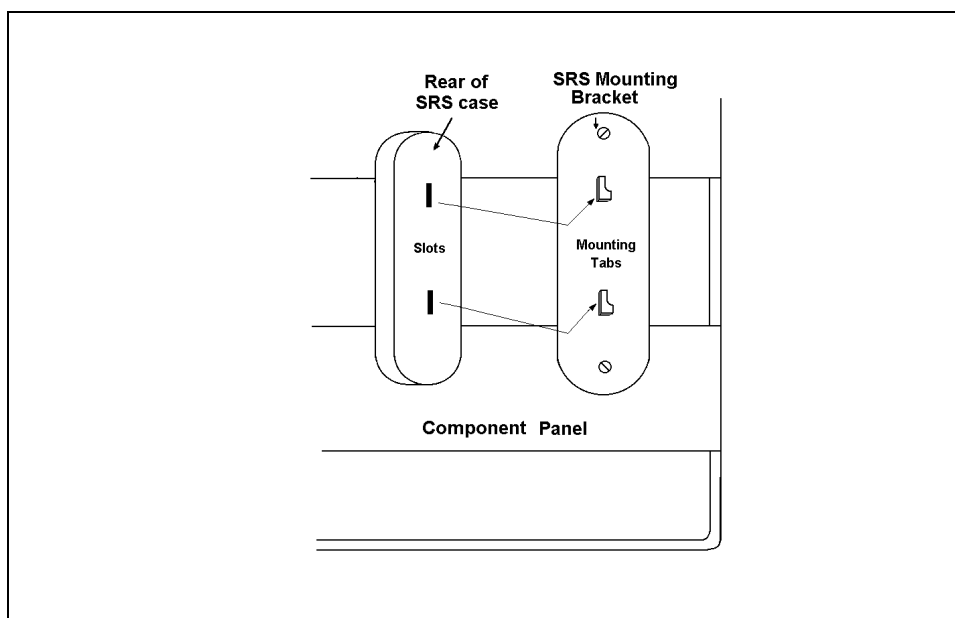

Figure B-8. SRS Installation

B.2.8 Solenoid Valve Connections to the Pump

Connect air-actuated solenoid valves between pump and the LC20 for control of the column select and injection valves. Refer to the pump operator's manual for installation instructions.

A

Abnormal retention time, 4-6
Abnormal selectivity, 4-6
Air leaks, 4-5

C

Cell cable connectors, 2-13
Column installation, B-12
Column select valve, 2-8
Columns
 Guard columns, 2-7
 Separator columns, 2-7
Connectors
 Cell cable connectors, 2-13

D

Description
 Cell cable connectors, 2-13
 Column select valve, 2-8
 Detector cells, 2-11
 Guard columns, 2-7
 Leak sensor, 2-7
 Overview, 2-3
 Physical, A-3
 Rheodyne injection valve, 2-3, 2-6
 Self-Regenerating Suppressor, 2-7, B-13
 Separator columns, 2-7
 Solenoid interface, 2-13, B-14
Detector cell plumbing, B-9
Detector cells, 2-11
DS3 Detection Stabilizer, 2-11

E

Environmental specifications, A-3

F

Facilities required, B-3
Front panel, 2-3

G

Guard columns, 2-7

H

Hydraulic specifications, A-3

I

Injection valve, 2-3, 2-6
 Sample loading, 3-4
 Solenoid interface, 2-13, B-14
Injection valve connections, B-7
Installation, B-3
 Column installation, B-12
 Detector cell plumbing, B-9
 Facilities required, B-3
 Injection valve connections, B-7
 Leak Control, B-6
 Liquid Line Connections, B-6
 Rear Panel, 2-12
 Solenoid interface, 2-13, B-14
 SRS installation, B-13
 Stacking modules, B-4
 Waste line, 2-13, B-5
Interior components, 2-4
 Column select valve, 2-8
 Detector cells, 2-11
 DS3 Detection Stabilizer, 2-11
 Guard columns, 2-7
 Leak sensor, 2-7
 Self-Regenerating Suppressor, 2-7, B-13
 Separator columns, 2-7

LC20 Chromatography Enclosure

L

Leak Control, B-6
Leak sensor, 2-7
Liquid leaks, 4-3
Liquid Line Connections, B-6

M

Maintenance
 Abnormal retention time, 4-6
 Abnormal selectivity, 4-6
 Air leaks, 4-5
 Liquid leaks, 4-3
 Peak ghosting, 4-6
 Routine maintenance, 3-7

O

Operation
 Sample loading, 3-4
 Shutdown, 3-7
Options
 DS3 Detection Stabilizer, 2-11
 Self-Regenerating Suppressor, 2-7, B-13

P

Peak ghosting, 4-6
Physical description, A-3
 Front panel, 2-3
 Interior components, 2-4
 Rear Panel, 2-12

R

Rear Panel, 2-12
Routine maintenance, 3-7

S

Sample loading, 3-4
Separator columns, 2-7
Service, 5-1
Shutdown, 3-7
Solenoid interface, 2-13, B-14
Specifications, A-3
 Environmental, A-3
 Hydraulic, A-3
SRS
 seeSelf-Regenerating Suppressor
SRS installation, B-13
Stacking modules, B-4

T

Troubleshooting, 4-3, 4-5, 4-7
 Abnormal retention time, 4-6
 Abnormal selectivity, 4-6
 Air leaks, 4-5
 Liquid leaks, 4-3
 Peak ghosting, 4-6

W

Waste line installation, 2-13, B-5



Artisan Technology Group is your source for quality new and certified-used/pre-owned equipment

- FAST SHIPPING AND DELIVERY
- TENS OF THOUSANDS OF IN-STOCK ITEMS
- EQUIPMENT DEMOS
- HUNDREDS OF MANUFACTURERS SUPPORTED
- LEASING/MONTHLY RENTALS
- ITAR CERTIFIED SECURE ASSET SOLUTIONS

SERVICE CENTER REPAIRS

Experienced engineers and technicians on staff at our full-service, in-house repair center

*InstraView*SM REMOTE INSPECTION

Remotely inspect equipment before purchasing with our interactive website at www.instraview.com ↗

WE BUY USED EQUIPMENT

Sell your excess, underutilized, and idle used equipment. We also offer credit for buy-backs and trade-ins. www.artisanng.com/WeBuyEquipment ↗

LOOKING FOR MORE INFORMATION?

Visit us on the web at www.artisanng.com ↗ for more information on price quotations, drivers, technical specifications, manuals, and documentation

Contact us: (888) 88-SOURCE | sales@artisanng.com | www.artisanng.com