



## Artisan Technology Group is your source for quality new and certified-used/pre-owned equipment

- FAST SHIPPING AND DELIVERY
- TENS OF THOUSANDS OF IN-STOCK ITEMS
- EQUIPMENT DEMOS
- HUNDREDS OF MANUFACTURERS SUPPORTED
- LEASING/MONTHLY RENTALS
- ITAR CERTIFIED SECURE ASSET SOLUTIONS

### SERVICE CENTER REPAIRS

Experienced engineers and technicians on staff at our full-service, in-house repair center

### *InstraView*<sup>SM</sup> REMOTE INSPECTION

Remotely inspect equipment before purchasing with our interactive website at [www.instraview.com](http://www.instraview.com) ↗

### WE BUY USED EQUIPMENT

Sell your excess, underutilized, and idle used equipment. We also offer credit for buy-backs and trade-ins. [www.artisanng.com/WeBuyEquipment](http://www.artisanng.com/WeBuyEquipment) ↗

### LOOKING FOR MORE INFORMATION?

Visit us on the web at [www.artisanng.com](http://www.artisanng.com) ↗ for more information on price quotations, drivers, technical specifications, manuals, and documentation

**Contact us:** (888) 88-SOURCE | [sales@artisanng.com](mailto:sales@artisanng.com) | [www.artisanng.com](http://www.artisanng.com)



## **IP-488**

IEEE-488 (GPIB)  
Instrumentation Bus  
IndustryPack®

User Manual

©SBS Technologies, Inc.  
Subject to change without notice.  
Hardware Revision: D  
Part # 89002057 Rev. 1.1  
20050505

**IP-488**  
**IEEE-488 (GPIB)**  
**Instrumentation Bus**  
**IndustryPack®**

**SBS Technologies, Inc.**  
**1284 Corporate Center Drive**  
**St. Paul, MN 55121**  
**Tel (651) 905-4700**  
**FAX (651) 905-4701**  
**Email: [support.commercial@sbs.com](mailto:support.commercial@sbs.com)**  
**<http://www.sbs.com>**

©1999, 2005 SBS Technologies, Inc.  
IndustryPack is a registered trademark of SBS Technologies, Inc. QuickPack, SDpack and Unilin are trademarks SBS Technologies, Inc. PC•MIP is a trademark of SBS Technologies, Inc. and MEN Mikro GmbH.

SBS Technologies, Inc acknowledges the trademarks of other organizations for their respective products mentioned in this document.

All rights are reserved: No one is permitted to reproduce or duplicate, in any form, the whole or part of this document without the express consent of SBS Technologies, Inc. This document is meant solely for the purpose in which it was delivered.

SBS Technologies, Inc. reserves the right to make any changes in the devices or device specifications contained herein at any time and without notice. Customers are advised to verify all information contained in this document.

The electronic equipment described herein generates, uses and may radiate radio frequency energy, which can cause radio interference. SBS Technologies, Inc. assumes no liability for any damages caused by such interference.

SBS Technologies, Inc.'s products are **not** authorized for use as critical components in medical applications such as life support equipment, without the express consent of the general manager of SBS Technologies, Inc. Commercial Group.

---

---

# Table of Contents

---

---

Product Description.....	5
VMEbus Addressing.....	7
NuBus Addressing.....	8
Programming.....	9
User Options .....	10
IEEE-488 Bus Overview .....	11
ID PROM.....	12
I/O Pin Wiring .....	13
Construction and Reliability .....	14
Repair .....	15
Specifications .....	16

---

---

# List of Figures

---

---

Figure 1	Simplified Block Diagram of IP-488 .....	6
Figure 2	VMEbus Register Map .....	7
Figure 3	NuBus Register Map .....	8
Figure 4	IEEE-488 Bus Connector Pin Assignment .....	11
Figure 5	ID PROM Data (hex) .....	12
Figure 6	IP-488 I/O Pin Assignment.....	13

# Product Description

IP-488 is part of the Industry Pack™ family of modular I/O components. It provides talker, listener and controller access to the IEEE-488 instrumentation bus (GPIB). IP-488 is compatible with IEEE-488.1 and IEE-488.2.

IP-488 is a straight forward implementation of National Instruments' NAT9914A. The NAT9914A is pin for pin compatible with Texas Instruments' popular TMS9914A with enhanced capabilities (i.e IEEE488.2). Users will find both programming and applications easier if they have reference to the Texas Instruments' "TMS9914A General Purpose Interface Bus (GPIB) Controller Data Manual," the "TMS9914A GPIB Controller User's Guide" (document no. SPPU013), and National Instruments' NAT9914A IEEE488.2 data sheet. These documents are available from Texas Instruments and National Instruments.

The interface from the 9914A to the IP carrier is conventional, using 8-bits only on odd bytes. The base address of the chip is the same as the base address assigned to the IP slot on the IP carrier board. Two additional addresses are implemented outside the chip to read the 6-bit address switch and access the interrupt vector register. These addresses are shown in the address maps shown in the next sections. The LSB of the vector register also serves as a control line for the System Controller function (SC).

The interface from the 9914A to the instrumentation bus is implemented with two Texas Instruments octal transceivers designed specifically for this purpose: 75ALS160 and 75ALS164. These parts feature: direct control by the 9914A (except for SC), bus terminating resistors, glitch free power-up and power-down, and receiver hysteresis. The bus interface lines are protected from ESD damage by SBS' unique LineSafe™ protection circuit. The same filters attenuate any EMI to help the final system meet FCC/CE EMI standards.

All control circuitry, the ID PROM, and the interrupt vector register is implemented within an Altera EPM7032.

A simple interrupt architecture uses a single programmable vector for all 9914A interrupts. Two 8-bit interrupt status/mask registers inside the 9914A support powerful and flexible software.

An adapter cable connects the 50-pin flat ribbon connector on the carrier board to the industry standard IEEE-488 bus connector.

The IP-488 conforms to the Industry Pack Interface Specification. This guarantees compatibility with multiple IP carrier boards. Because the IPs may be mounted on different form factors, while maintaining plug and software compatibility, system prototyping may be done on one carrier board, with final system implementation on a different one.

A block diagram of the IP-488 is shown in Figure 1 on the next page.

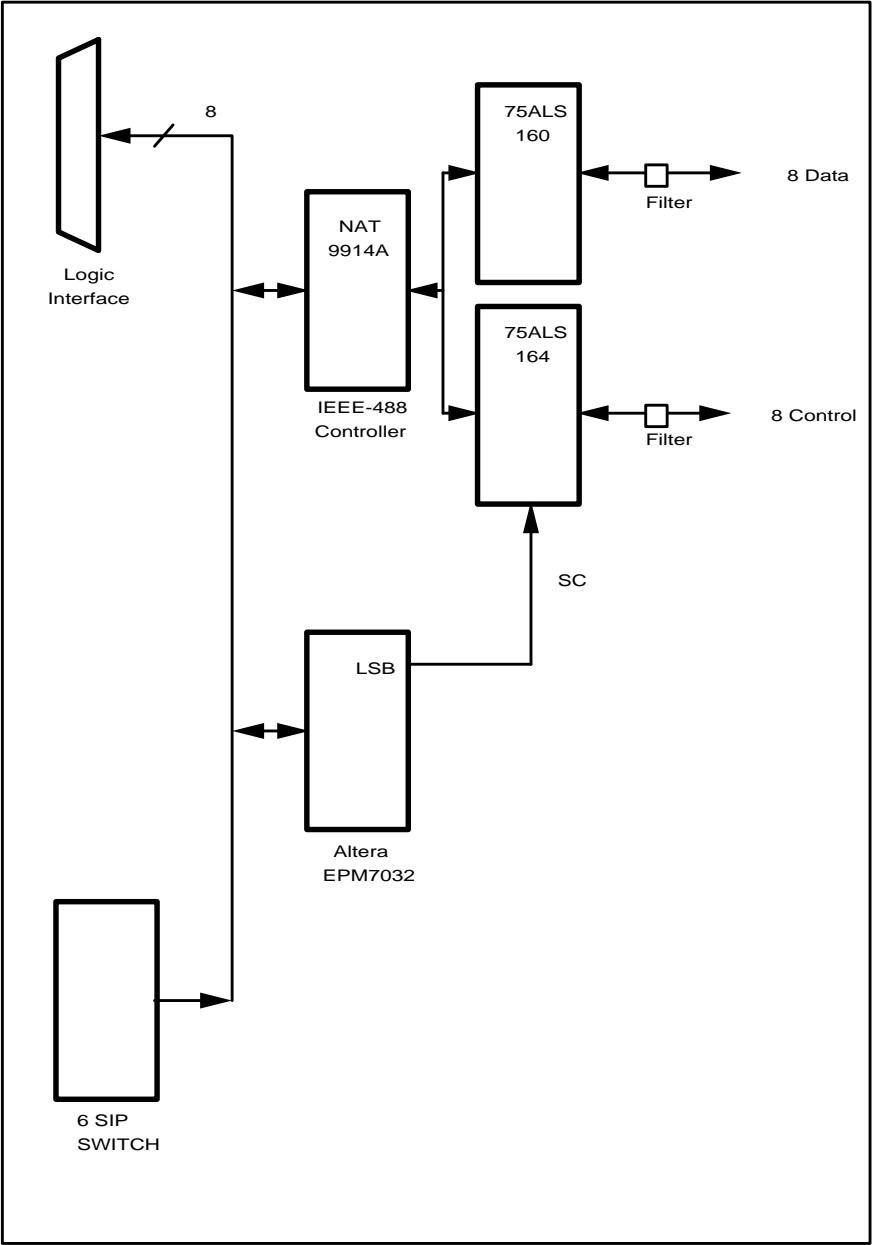

**Figure 1 Simplified Block Diagram of IP-488**

# VMEbus Addressing

The IP-488 provides direct access to the eight internal registers of the NAT9914A chip. Each register occupies one byte on odd boundaries. The base address is determined by the base address of the I/O space for the IP position by the IP carrier board. These are the first eight entries in Figure 2.

In addition, the IP-488 provides access to two registers outside the NAT9914A. These are the interrupt vector register and the 6-bit switch register. These are the last two entries in Figure 2.

For NuBus applications refer to the NuBus Addressing section below.

<b>Address</b>	<b>Function</b>
base + 1	Int Status/Mask 0 (R/W)
base + 3	Int Status/Mask 1 (R/W)
base + 5	Address Status (R)
base + 7	Bus Status/Aux Command (R/W)
base + 9	Address (W)
base + B	Serial Poll (W)
base + D	Command Pass/Parallel Poll (R/W)
base + F	Data In/Data Out (R/W)
base +11	Address Switch (R)
base +13	Vector Register (R/W)

Note: The LSB of the Vector Register is System Controller (SC), which controls REN and IFC direction: 1 for Transmit (SC), 0 for Receive (non SC)

**Figure 2 VMEbus Register Map**



# NuBus Addressing

The IP-488 provides direct access to the eight internal registers of the NAT9914A chip. Each register occupies one byte on alternate odd boundaries. The base address is determined by the base address of the IP carrier board. These are the first eight entries in Figure 3.

In addition, the IP-488 provides access to two registers outside the NAT9914A. These are the interrupt vector register and the 6-bit switch register. These are the last two entries in Figure 3.

For VMEbus applications refer to the VMEbus Addressing section previous.

<b>RM1260 Address</b>	<b>RM1270 Address</b>	<b>Function</b>
base + 1	base + 3	Int Status/Mask 0 (R/W)
base + 5	base + 7	Int Status/Mask 1 (R/W)
base + 9	base + B	Address Status (R)
base + D	base + F	Bus Status/Aux Command (R/W)
base + 11	base + 13	Address (W)
base + 15	base + 17	Serial Poll (W)
base + 19	base + 1B	Command Pass/Parallel Poll (R/W)
base + 1D	base + 1F	Data In/Data Out (R/W)
base + 21	base + 23	Address Switch (R)
base + 25	base + 27	Vector Register (R/W)

Note: The LSB of the Vector Register is System Controller (SC), which controls REN and IFC direction: 1 for Transmit (SC), 0 for Receive (non SC)

**Figure 3 NuBus Register Map**

# Programming

Programming the IP-488 is supported under IBF file manager, which runs under OS-9.

IBF is a comprehensive package that includes 16 shell commands, 19 OS-9 system functions, and 23 C Language library functions. Familiar file constructs such as, “open,” “read,” and “write” are used.

Some systems integrators may wish to write their own drivers. Programming the NAT9914A is similar to programming a conventional serial chip. Drivers are available for the NAT9914A under several real-time kernels. Limited example programs are provided in the TMS9914A manuals which are available from Texas Instruments.

# User Options

The only user option on the IP-488 is the setting of the six position DIP switch. This switch may be read by software. Switches are commonly used on GPIB equipment to allow mechanical setting of the bus address. Since in all cases the software must read the switch first, then program the TMS9914A with the address, this capability is a function of software, and is not implemented directly on the IP.

The bus address switch is mounted on the edge of the IP-488. The switch must be set prior to installing the IndustryPack into the carrier board or the carrier board into the backplane. The switch may be ignored in some applications, for example by interrogating the user through a dialog box, or by retrieving this information from a setup file.

The six separate switches in the DIP switch control what is read from the 6 LSBs of the switch register. Bits D6 and D7 should be ignored when reading the switch. A switch in the "off" position (i.e. closest to the edge of the board) will cause the corresponding bit to be read as a "0," while a switch in the "on" position (i.e. away from the edge of the board) will cause the corresponding bit to be read as a "1." Pin one of the switch (which is indicated by the letters "LSB" on the silk screen and is located closest to P2) corresponds to D0 (LSB) of the data read. Pin six corresponds to D5 and is marked on the silk screen as "MSB." Note that IEEE-488 valid addresses must be between one and thirty one. The factory default setting for all six of the switches is "off."

# IEEE-488 Bus Overview

Much of the information in this section is adapted from Texas Instruments TMS9914A Data Manual. Information concerning IEEE488.2 can be found in the National Instruments' NAT9914A data sheet.

The GPIB is another name for the IEEE-488 Instrumentation Bus. The Hewlett Packard company uses the designation HPIB for implementation. HP, Tektronix, the John Fluke Manufacturing Company and others manufacture a wide range of laboratory, calibration and production instrumentation that uses the GPIB to communicate.

Most systems have one or more Controllers, typically a general purpose programmable computer with real-time capabilities. The GPIB permits up to 15 instruments or computers within a localized area to communicate with each other over a common bus. Each device has a unique address, which is often read from user-accessible switches at power-on. The basic operating modes of GPIB devices are Talker, Listener, and Controller. Many devices can both talk and listen. Most controllers also have talker and listener capability.

Information is transmitted in a byte serial format by one talker to any number of listeners. Information consists of either data or commands. Eight data lines plus eight control lines (and eight ground lines) make up the bus. The pin assignments of these lines are given in Figure 4 below. Three of the control lines operate as a 3-wire handshake between talker (or controller) and listeners. No new data is sent until each device addressed to listen has received the previous byte and is ready for the next. This method of asynchronous communication ensures that the data rate is suited to the slowest active listener.

A standard 24-pin connector and cable is used. Instruments have female connectors and the cables have two male connectors. Cables also have each end of a second female connector. This permits stacking of cable connections at the connectors, somewhat like Christmas tree light strings. Cables are typically six or nine feet each. AMP Incorporated, as well as many other firms sell prefabricated cables. A six foot adapter cable from the IP carrier board to the standard cable is available from SBS.

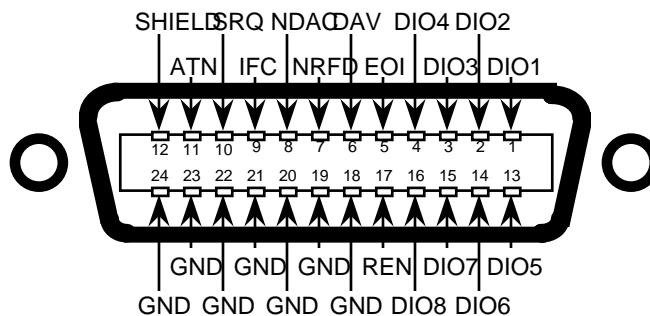

**Figure 4 IEEE-488 Bus Connector Pin Assignment**

# ID PROM

Every IP contains an IP PROM, whose size is at least 32 x 8 bits. The ID PROM aids in software auto configuration and configuration management. The ID PROM on the IP-488 is realized in an Altera 7032, also where all of the IP logic is found. The user's software, or a supplied driver, may verify that the device it expects is actually installed at the location it expects, and is nominally functional. The ID PROM contains the manufacturing revision level of the IP. If a driver requires that a particular revision be present, it may check for it directly.

Standard data in the ID PROM on the IP-488 is shown in Figure 5 below. For more information on IP ID PROMs refer to the IndustryPack Logic Interface Specification.

The location of the ID PROM in the host's address space is dependent on which carrier is used. Normally for VMEbus carriers the ID PROM space is directly above the IP's I/O space, or at IP-base + \$80. Macintosh drivers use the ID PROM automatically. RM1260 address may be derived from Figure 5 below by multiplying the addresses given by two, then subtracting one. RM1270 addresses may be derived by multiplying the addresses given by two, then adding one.

3F	(available for user)	
19		
17	CRC	(7C)
15	No of bytes used	(0B)
13	Driver ID, high byte	(00)
11	Driver ID, low byte	(00)
0F	reserved	(00)
0D	Revision	(C1)
0B	Model No IP-488	(14)
09	Manufacturer ID SBS	(F0)
07	ASCII "C"	(43)
05	ASCII "A"	(41)
03	ASCII "P"	(50)
01	ASCII "I"	(49)

**Figure 5 ID PROM Data (hex)**

# I/O Pin Wiring

This section gives the pin assignments for IP-488. The pin numbers given below correspond to numbers on the 50-pin IndustryPack I/O connector and to the wires on a 50-pin flat cable plugged into a standard IP carrier board.

1	OUT D1	26 N/C
2	OUT D5	27 N/C
3	OUT D2	28 N/C
4	OUT D6	29 N/C
5	OUT D3	30 N/C
6	OUT D7	31 N/C
7	OUT D4	32 N/C
8	OUT D8	33 N/C
9	OUT EO1	34 N/C
10	OUT REN	35 N/C
11	OUT DEV	36 N/C
12	GND	37 N/C
13	OUT NFRD	38 GND
14	GND	39 OUT PE
15	OUT NDAC	40 GND
16	GND	41 OUT TE
17	OUT IFC	42 GND
18	GND	43 OUT DC
19	OUT SPQ	44 GND
20	GND	45 OUT SC
21	OUT ATN	46 GND
22	GND	47 +5V
23	GND	48 +5V
24	GND	49 +5V
25	N/S	50 +5V

**Figure 6 IP-488 I/O Pin Assignment**

# Construction and Reliability

IndustryPacks were conceived and engineered for rugged industrial environments. The IP-488 is constructed out of 0.062 inch thick FR4 material. The four copper layers consist of two signal layers on the top and bottom, and two internal layers for power distribution.

All components on the IP are surface mount components, except for the two 50 pin connectors and the two test points which are through hole. Surface mounting of components allows for high reliability and low cost.

The IndustryPack connectors are keyed, shrouded and gold plated on both contacts and receptacles. They are rated at 1 Amp per pin, 200 insertion cycles minimum. These connectors make consistent, correct insertion easy and reliable.

The IP is secured to the carrier with four metric M2 stainless steel screws. The heads of the screws are countersunk into the IP. The four screws provide significant protection against shock, vibration, and incomplete insertion. For most applications they are not required.

The IndustryPack provides a low temperature coefficient of 0.89 W/°C for uniform heat. This is based on the temperature coefficient of the base FR4 material of .31 W/m-°C, and taking into account the thickness and area of the IP. This coefficient means that if 0.89 Watts is applied uniformly on the component side, that the temperature difference between the component and the solder side is one degree Celsius.

# Repair

## Service Policy

Before returning a product for repair, verify as well as possible that the suspected unit is at fault. Then call the factory for a RETURN MATERIAL AUTHORIZATION (RMA) number. Carefully package the unit, in the original shipping carton if this is available, and ship prepaid and insured with the RMA number clearly written on the outside of the package. Include a return address and the telephone number of a technical contact. For out-of-warranty repairs, a purchase order for repair charges must accompany the return. SBS will not be responsible for damages due to improper packaging of returned items.



# Specifications

Logic Interface	Industry Pack Logic Interface
IEEE-488 Controller	NAT9914A
Capabilities	Handles all IEEE-488 1975/1978 functions Compatible with IEEE-488.2 Talker, Listener, Controller
Bus Interface	LineSafe™ protection circuitry on all bus interface lines protect the IP from ESD damage. The same filters attenuate any EMI to help the final system meet FCC/CE EMI standards.
Node Address	Settable by software or on-board switch
Wait States	Zero on read cycles One on write cycles
Interrupt	Eight bit vectored interrupts
Memory Space	None. There are no features of this IP accessible via the IP memory space. Access to the memory space of this IP by the host will typically result in a host bus time-out error.
Dimensions	1.800 by 3.900 by 0.340 inches maximum
Environmental	Operating temperature: 0° to+ 70°C Humidity: 5% to 95% non-condensing Storage: -10° to +85°C



## Artisan Technology Group is your source for quality new and certified-used/pre-owned equipment

- FAST SHIPPING AND DELIVERY
- TENS OF THOUSANDS OF IN-STOCK ITEMS
- EQUIPMENT DEMOS
- HUNDREDS OF MANUFACTURERS SUPPORTED
- LEASING/MONTHLY RENTALS
- ITAR CERTIFIED SECURE ASSET SOLUTIONS

### SERVICE CENTER REPAIRS

Experienced engineers and technicians on staff at our full-service, in-house repair center

### *InstraView*<sup>SM</sup> REMOTE INSPECTION

Remotely inspect equipment before purchasing with our interactive website at [www.instraview.com](http://www.instraview.com) ↗

### WE BUY USED EQUIPMENT

Sell your excess, underutilized, and idle used equipment. We also offer credit for buy-backs and trade-ins. [www.artisanng.com/WeBuyEquipment](http://www.artisanng.com/WeBuyEquipment) ↗

### LOOKING FOR MORE INFORMATION?

Visit us on the web at [www.artisanng.com](http://www.artisanng.com) ↗ for more information on price quotations, drivers, technical specifications, manuals, and documentation

**Contact us:** (888) 88-SOURCE | [sales@artisanng.com](mailto:sales@artisanng.com) | [www.artisanng.com](http://www.artisanng.com)