



Artisan Technology Group is your source for quality new and certified-used/pre-owned equipment

- FAST SHIPPING AND DELIVERY
- TENS OF THOUSANDS OF IN-STOCK ITEMS
- EQUIPMENT DEMOS
- HUNDREDS OF MANUFACTURERS SUPPORTED
- LEASING/MONTHLY RENTALS
- ITAR CERTIFIED SECURE ASSET SOLUTIONS

SERVICE CENTER REPAIRS

Experienced engineers and technicians on staff at our full-service, in-house repair center

*InstraView*SM REMOTE INSPECTION

Remotely inspect equipment before purchasing with our interactive website at www.instraview.com ↗

WE BUY USED EQUIPMENT

Sell your excess, underutilized, and idle used equipment. We also offer credit for buy-backs and trade-ins. www.artisanng.com/WeBuyEquipment ↗

LOOKING FOR MORE INFORMATION?

Visit us on the web at www.artisanng.com ↗ for more information on price quotations, drivers, technical specifications, manuals, and documentation

Contact us: (888) 88-SOURCE | sales@artisanng.com | www.artisanng.com

Features

- International Class 1 laser safety certified
- 1062.5 Mb/s data rate
- (ANSI) Fibre Channel compliant [1]
- Gigabit Interface Converter (GBIC) Revision 5.4 compliant [2]
- Both short wavelength (850 nm) (distance ≤ 550 m) and long wavelength (1310 nm) (distance ≤ 10 km) products available
- Gigabit electrical serial interface
- Serial electrical \leftrightarrow light conversion
- UL and TUV approved
- Low bit error rate ($<10^{-12}$)

Overview

The Gigabit Interface Converters (GBICs) are integrated fiber optic transceivers that provide high-speed serial links at a signaling rate of 1062.5 Mb/s. The JGB-10SNAA1 and JGB-10SYAA1 conform to the American National Standards Institute's (ANSI) Fibre Channel, FC-0 specification for short wavelength operation (100-M5-SN-I and 100-M6-SN-I) [1]; the JGB-10LNAA1 and JGB-10LYAA1 conform to ANSI Fibre Channel FC-0 specification for long wavelength operation (100-SM-LC-L) [2].

These Gigabit Interface Converters (GBICs) are ideally suited for Fibre Channel links and Fibre Channel Arbitrated Loop (FC-AL) applications, but can be used for other serial applications where high data rates are required. These modules are hot-pluggable and permit easy manufacturing and field configuration between shortwave, longwave, and copper implementations of the various standards.

The shortwave GBICs use short wavelength (850nm) VCSEL lasers. This enables low cost data transmission over optical fibers at distances up to 550 m. A 50/125 μ m multimode optical fiber, terminated with an industry standard SC connector, is the preferred medium. A 62.5/125 μ m multimode fiber can be substituted with shorter maximum link distances.

Applications

- Gigabit Fibre Channel
- Client/Server environments
- Distributed multi-processing
- Fault tolerant applications
- Visualization, real-time video, collaboration
- Channel extenders, data storage, archiving
- Data acquisition

The longwave GBICs use long wavelength (1310nm) lasers. This enables data transmission over optical fibers at distances up to 10 km on a single mode (9/125 μ m) optical fiber.

The GBICs with Serial ID feature a 1 kbit EEPROM. The serial ID module can store up to 128 bytes of product information.

Encoded (8B/10B) [3, 4], gigabit/sec, serial, differential, PECL signals traverse a 20-pin straddle mount connector interfacing the GBIC to the host card. The serial data modulates the laser and is sent out over the outgoing fiber of a duplex cable.

Incoming, modulated light is detected by a photoreceiver mounted in the SC receptacle. The optical signal is converted to an electrical one, amplified, and delivered to the host card. This module is designed to work with industry standard Serializer/Deserializer modules.

These Gigabit Interface Converters are Class 1 laser safe products. The optical power levels, under normal operation, are at eye safe levels. Optical fiber cables can be connected and disconnected without shutting off the laser transmitter.

Fibre Channel GBIC

Pin Configuration

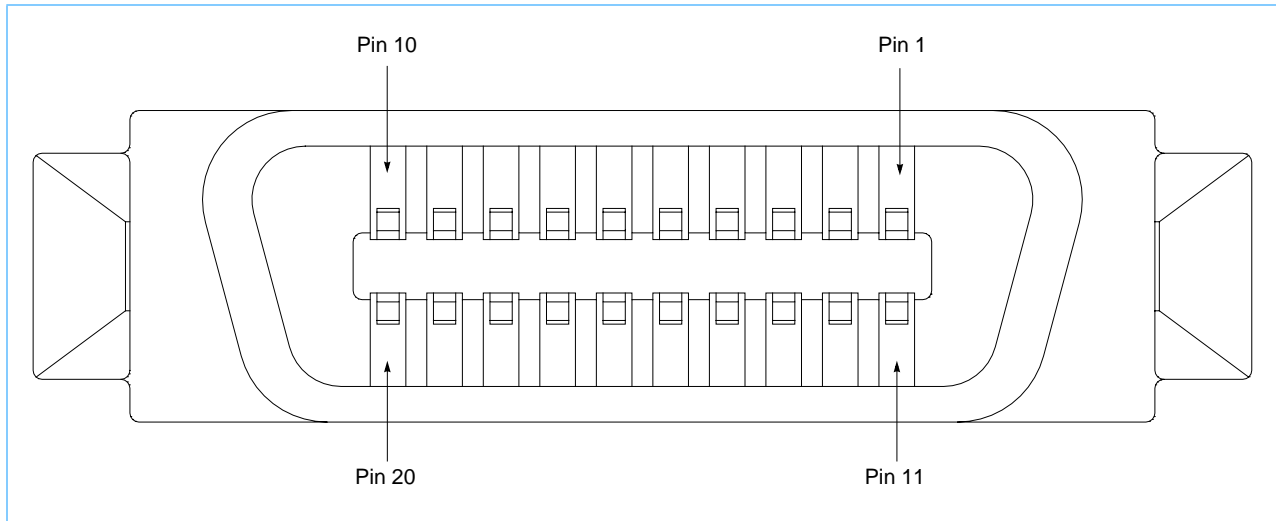

Pin Definitions

Pin #	Pin Name	Type	Sequence	Pin #	Pin Name	Type	Sequence
1	Rx_LOS	Status Out	2	11	RGND	Ground	1
2	RGND	Ground	2	12	-Rx_DAT	Data Out	1
3	RGND	Ground	2	13	+Rx_DAT	Data Out	1
4	MOD_DEF(0)	Output	2	14	RGND	Ground	1
5	MOD_DEF(1)	Input/Output ¹	2	15	V _{DDR}	Power	2
6	MOD_DEF(2)	Input/Output ¹	2	16	V _{DDT}	Power	2
7	Tx_Disable	Control In	2	17	TGND	Ground	1
8	TGND	Ground	2	18	+Tx_DAT	Data In	1
9	TGND	Ground	2	19	-Tx_DAT	Data In	1
10	Tx_Fault	Status Out	2	20	TGND	Ground	1

1. MOD_DEF(1) and MOD_DEF(2) are inputs and outputs for Serial ID GBICs only.
 GBIC-1063N and GBIC-1063N-LW use MOD_DEF(1) and MOD_DEF(2) as outputs only.

Ordering Information

Part Number	Product Descriptor	Wavelength	Data Rate	Standards Conformance	Serial ID
JGB-10SNAA1	GBIC-1063N	850 nm	1062.5 Mb/s	100-M5-SN-I 100-M6-SN-I	N
JGB-10SYAA1	GBIC-1063NS	850 nm	1062.5 Mb/s	100-M5-SN-I 100-M6-SN-I	Y
JGB-10LNAA1	GBIC-1063N-LW	1310 nm	1062.5 Mb/s	100-SM-LC-L	N
JGB-10LYAA1	GBIC1063NS-LW	1310 nm	1062.5 Mb/s	100-SM-LC-L	Y

Laser Safety Compliance Requirements

The GBICs are designed and certified as Class 1 laser products. If the power supply voltage exceeds 6.0 volts, the GBIC may no longer remain Class 1 products. The system using the GBIC must provide power supply over voltage protection that guarantees the supply does not exceed 6.0 volts under all fault conditions.

Operating the power supply above 6.0 V, or otherwise operating the GBIC in a manner inconsistent with their design and function may result in hazardous radiation exposure, and may be considered an act of modifying or new manufacturing of a laser product under US regulations contained in 21 CFR(J) or CENELEC regulations contained in EN 60825.

The person(s) performing such an act is required by law to recertify and reidentify the product in accordance with the provisions of 21 CFR(J) for distribution within the USA., and in accordance with provisions of CENELEC EN 60825 (or successive regulations) for distribution within the CENELEC countries or countries using the IEC 825 standard.

Fibre Channel GBIC

Block Diagram

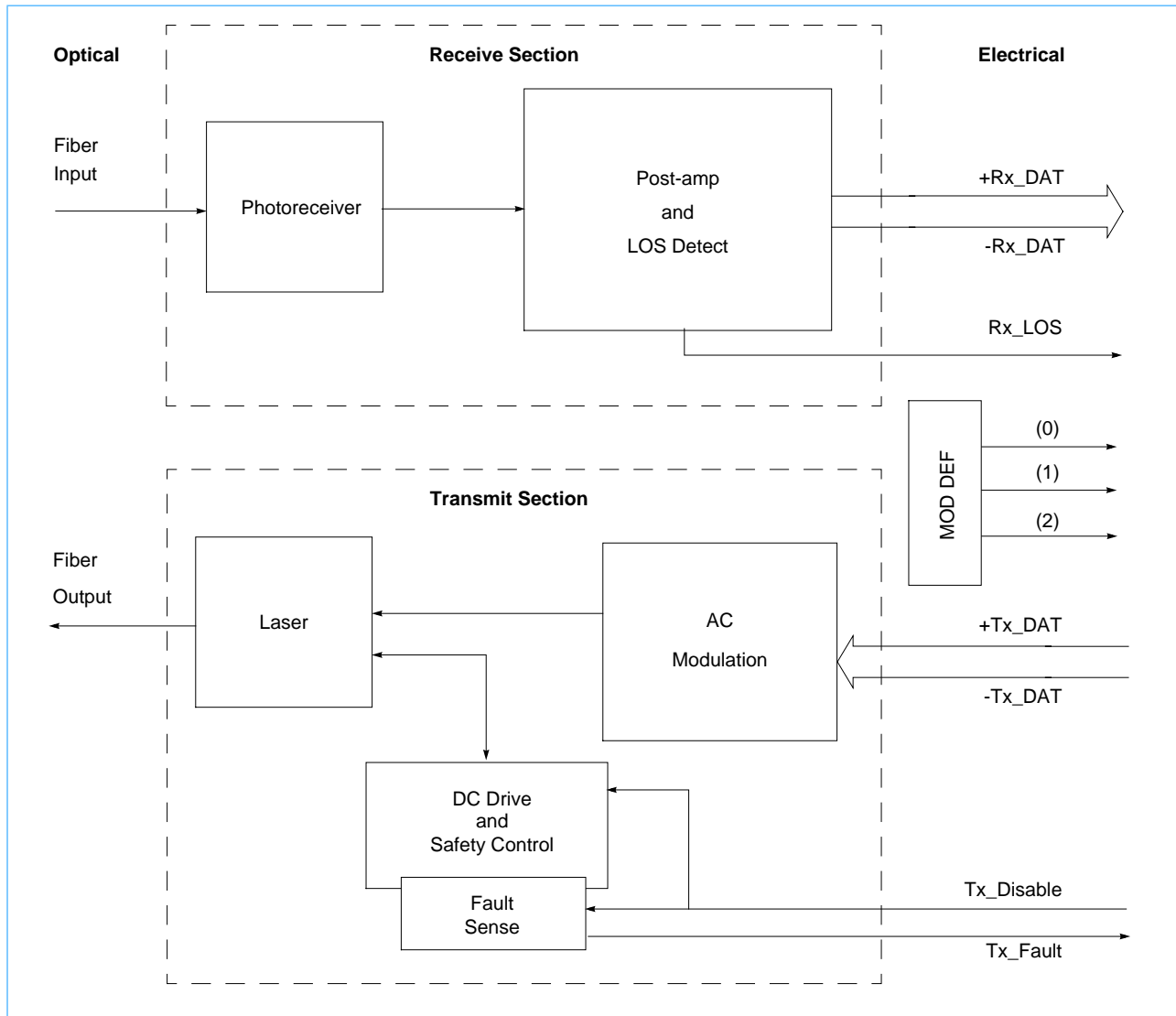

Transmit Section

The input differential, serial data stream enters the AC Modulation section of the laser driver circuitry where it modulates a semiconductor laser. The DC Drive maintains the laser at the correct preset power level. In addition, there are safety circuits in the DC Drive that will shut off the laser if a fault is detected.

Receive Section

The incoming, modulated optical signal is converted to an electrical signal by the photoreceiver. This electrical signal is then amplified and converted to a differential, serial output data stream and delivered to the host. A transition detector detects a minimum AC level of modulated light entering the photoreceiver. This signal is provided to the host as a loss-of-signal status line.

Output Signal Definitions

MOD_DEF(0:2)

Pins 4, 5, and 6 define the data rate at which the installed GBIC is operating, as shown in the following table.

Module Pin Definitions

MOD_DEF (0) Pin 4	MOD_DEF (1) Pin 5	MOD_DEF (2) Pin 6	Interpretation by Host
0	1	0	Shortwave GBIC
1	0	0	Longwave GBIC
0	1	1	GBIC with Serial ID

MOD_DEF(0:2) Serial ID Implementations

In the GBICs with serial ID, a two-wire serial EEPROM is used to hold 128 bytes of information that describe some of the capabilities, standard interfaces, manufacturer, and other information relevant to the product. The information stored in the EEPROM is protected so that it cannot be changed by the user. Tables describing the specific addresses and values of the serial ID data are included in Serial ID Data and Descriptions on page 21. Operation of the serial ID function is described in Serial Module Definition Protocol (Serial ID) on page 10. Signal timings necessary for proper operation of the serial ID function are shown in Serial ID Timing Specifications on page 20.

The serial ID module requires both serial clock (SCL) and serial data I/O (SDA) connections. These signals are required to have pull up resistors (4.7 kΩ is the recommended value; however, a smaller value may be needed in order to meet the serial ID's rise and fall time requirements). The following list and figure show the necessary connections from an interface to a GBIC to ensure the capability of reading the serial ID data.

- MOD_DEF(0): Logic Low
- MOD_DEF(1): SCL
- MOD_DEF(2): SDA

The serial clock (SCL) and the serial data (SDA) lines appear as NC to the host system upon initial power up.

Expected Connections to GBIC MOD_DEF Pins

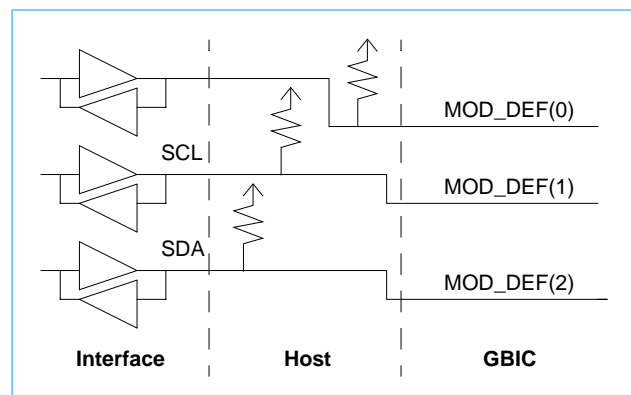

Fibre Channel GBIC

Rx_DAT

The incoming optical signal is converted and repowered as an AC coupled differential PECL serial data stream.

Rx_LOS

The Receive Loss of Signal line is high (a logical one) when there is no incoming light from the companion transceiver. (More accurately, this line indicates that the level of light is below that required to guarantee correct operation of the link. Normally, this only occurs when either the link is unplugged or the companion transceiver is turned off.) This signal is normally used by the system for diagnostic purposes. The timing is shown in the Receive Loss of Signal Detection diagram below.

This signal has an open collector TTL driver. A pull up resistor is required on the host side of the GBIC connector. The recommended value for this resistor is 10 kΩ.

Tx_Fault

Upon sensing an improper power level in the laser driver, the GBIC sets this signal high and turns off the laser. The Tx_Fault signal can be reset with the Tx_Disable line.

The laser is turned off within 100 μs as shown in the Transmitter Fault Detection timing diagram below.

This signal has an open collector TTL driver. A pull up resistor is required on the host side of the GBIC connector. The recommended value for this resistor is 10 kΩ.

Output Signal Timings

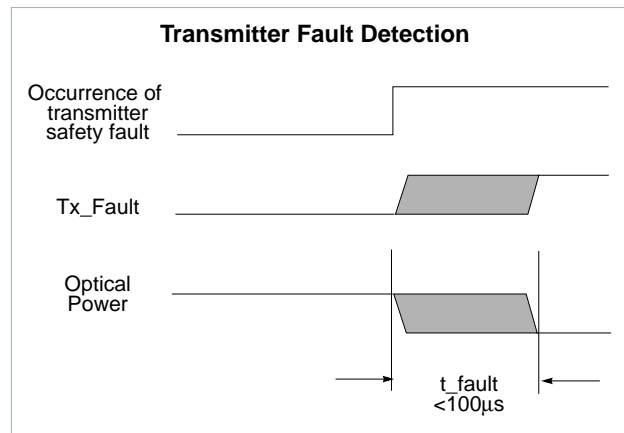
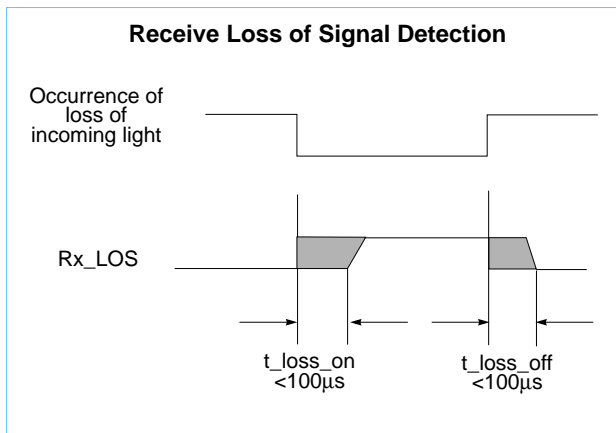

Input Signal Definitions

Tx_DAT

A differential PECL serial data stream is presented to the GBIC for transmission onto the optical fiber by intensity modulating a laser.

Tx_Disable

When high (logic one), the Tx_Disable signal turns off the power to both the AC and DC laser driver circuits. It will also reset the Tx_Fault output under some conditions (see Resetting a Fault (Tx_Fault) on page 8).

When low (logic zero), the laser will be turned on within 1ms if a hard fault is not detected. The timing diagram below shows this line under normal operating conditions.

Timing of Tx_Disable function

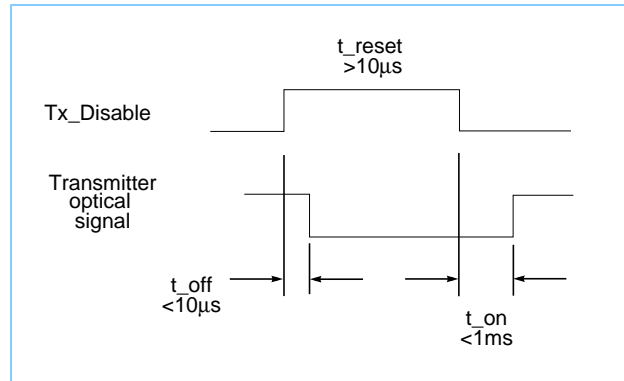

Power On Initialization Timings

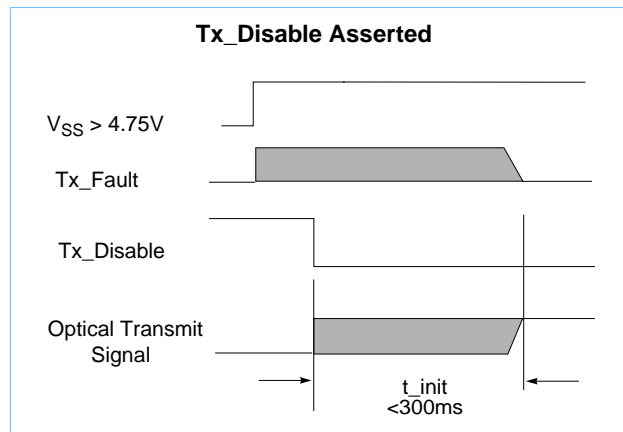
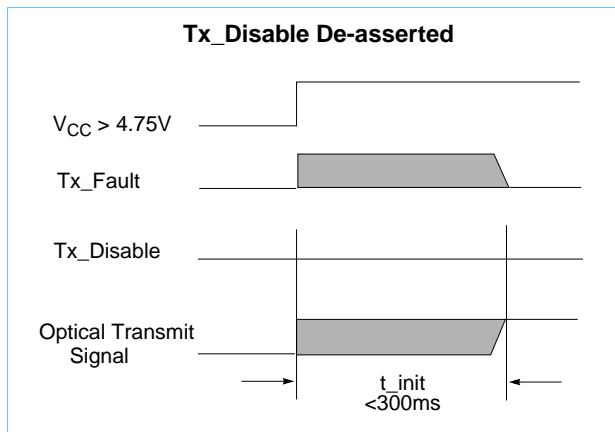

Fibre Channel GBIC

Resetting a Fault (Tx_Fault)

Resetting the Tx_Fault output by toggling the Tx_Disable input permits the GBIC to attempt to power on the laser following a fault condition. Continuous resetting and repowering of the laser under a hard fault condition could cause a series of optical pulses with sufficient energy to violate laser safety standards. To alleviate this possibility, the GBIC will turn off the laser and lock the Tx_Fault line high if a second fault is detected within 25 ms of the laser powering on. This lock is cleared during each power on cycle.

Fault Condition Recovery Timings

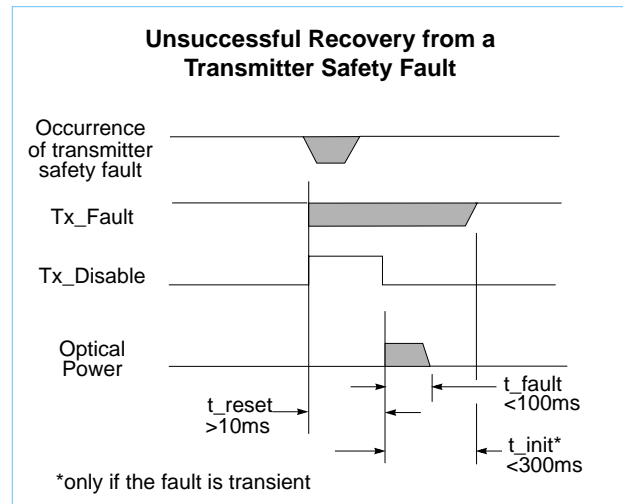
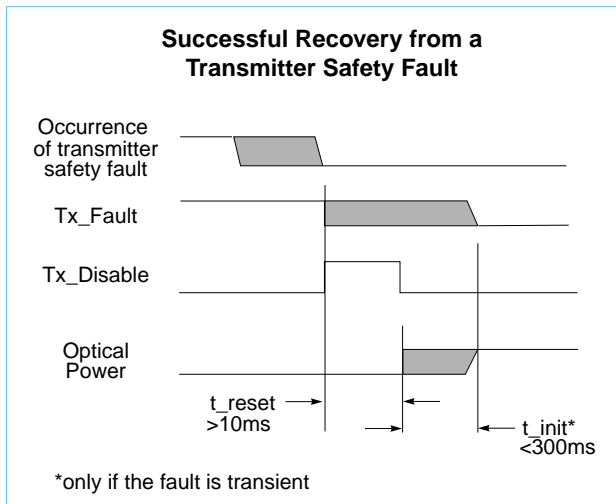

Operation

Link Acquisition Sequence

The following sequence should be followed to get a GBIC in full synchronization with a companion card undergoing a similar sequence. It will also work with a single card when using an optical wrap connector. This sequence assumes the use of an industry standard 10b Ser/Des chip.

1. Power up the node. The clock to the 10b chip should be running.
2. Drive the Transmit Data lines to 0101010101. (This speeds up the synchronization process and assures that the Comma Detect line on the 10b chip will not pulse randomly on the companion card during the remainder of the sequence.)
3. Drive the input control lines as follows:
 - a. Enable Wrap (10b chip): low (will not be changed)
 - b. Enable Comma Detect (10b chip): high (will not be changed)
 - c. $\overline{\text{Lock to Reference}}$ (10b chip): high
4. After the laser has come on, bring $\overline{\text{Lock to Reference}}$ low for at least 500 μs .
5. Bring the -Lock to Reference high.
6. After 2500 bit times (2.4 μs), the link should be in bit synchronization (the internal clocks are aligned to the incoming bit stream), but not yet byte synchronization (the byte is aligned along the same boundary it had when sent from the companion system to the GBIC prior to serialization). The Receive Byte Clock (10b chip) frequency should now be running at 0.1 times the bit rate and the Comma Detect line is ready to indicate reception of the Comma Character.
7. Drive the Transmit Data lines with a K28.5 (Byte Sync) character.

As soon as the 10b chip receives the K28.5 character from the other side of the link, the clocks will align to the byte boundary and all the Receive Data lines will have valid data. This will be indicated by the activation of the Comma Detect line.

Troubleshooting: What If ...

The laser never comes on (the Tx_Fault signal is either high or low):

- Verify 5 volts on the connector to the GBIC and that the module is correctly plugged.
- If the Tx_Fault line is high, try either unplugging and replugging or powering down the module to reset the Tx_Fault line (see "Resetting a Fault (Tx_Fault)" on page 8).
- Try another GBIC. If the replacement operates correctly then retry the original. If the original still fails, it is probably defective.
- If the replacement fails also, verify that Tx_Disable is low and that it toggles correctly on the connector.

The Rx_LOS signal remains high:

- Verify 5 volts on the connector to the GBIC and that the module is correctly plugged.
- Verify the level on pin 1 of the connector. If the level is correct, there might be a discontinuity on the host board.
- Try using a wrap connector or a simplex jumper to loop the transmitter to the receiver. If the Rx_LOS line goes low, the source of the optical signal or the link may be defective. Use an optical power meter to check the optical power level. If the average optical power is within specification (> -17 dBm for shortwave devices), then the GBIC might be faulty.

Fibre Channel GBIC

Serial Module Definition Protocol (Serial ID)

The GBICs with Serial ID have identifying information stored in a Serial ID EEPROM. To read the serial data from the serial ID module, the following must occur (refer to Serial ID Figures 1, 2, and 3 throughout these steps):

1. Send a start sequence to the module.
 This is done by changing the data line from high to low while the clock is high.
2. Send the set data address sequence.
 The set data address sequence is 10100000. This sequence will allow the user to set the memory address to start reading from.
 Note: Be sure to toggle the data line only when the clock is low. Toggling the data line while the clock is high indicates a start or stop condition.

Serial ID Figure 1 Start and Stop Timing

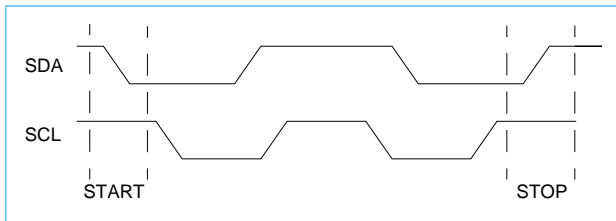

3. Receive an acknowledge signal.

Serial ID Figure 2 Set Data Address Sequence Timing

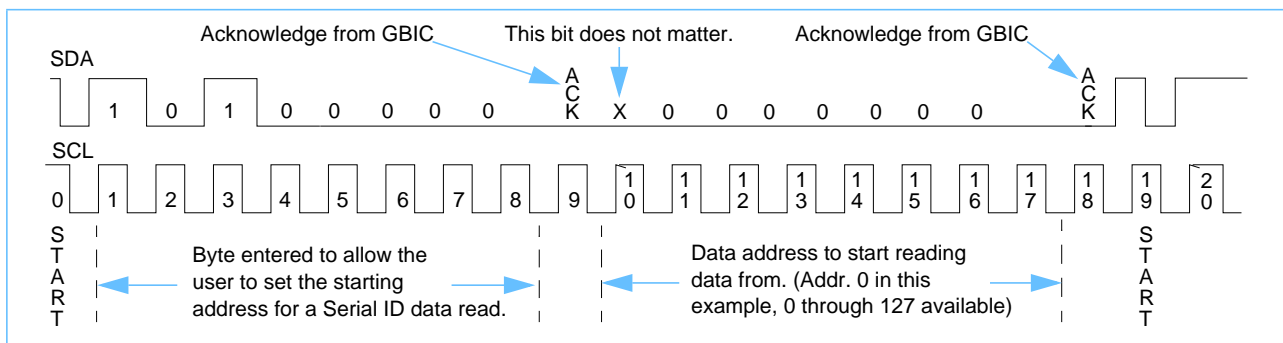

4. Send the address of the first byte to read.
 The most significant bit of the address byte is the first bit and is ignored.
5. Receive an acknowledge signal.
6. Send a start command.
7. Send the read data sequence.
 The read data sequence is 10100001. This sequence will allow the user to begin reading the data.
8. Receive an acknowledge signal.
9. Read a data word.
10. Send an acknowledge signal to receive the next data word or send a stop command to stop receiving data.
 A stop command is given by toggling the data from low to high while the clock is high.

The critical timings for communicating to the serial ID EEPROM are shown in Serial ID Figure 4 on page 11.

For more information on the Serial ID protocol, see Serial ID Data and Descriptions on page 21.

Serial ID Figure 3 Read Data Sequence Timing

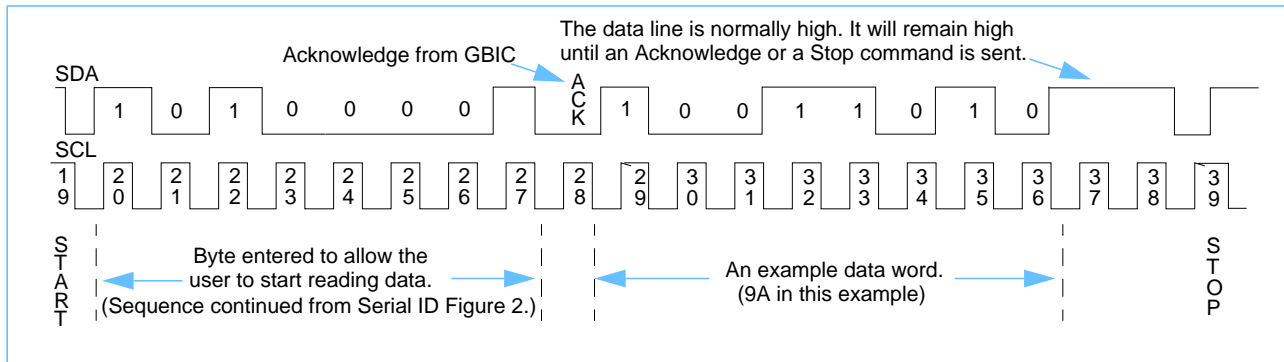

Serial ID Figure 4 Critical Timings for GBICs with Serial ID

Parameters are defined in Serial ID Timing Specifications on page 20.

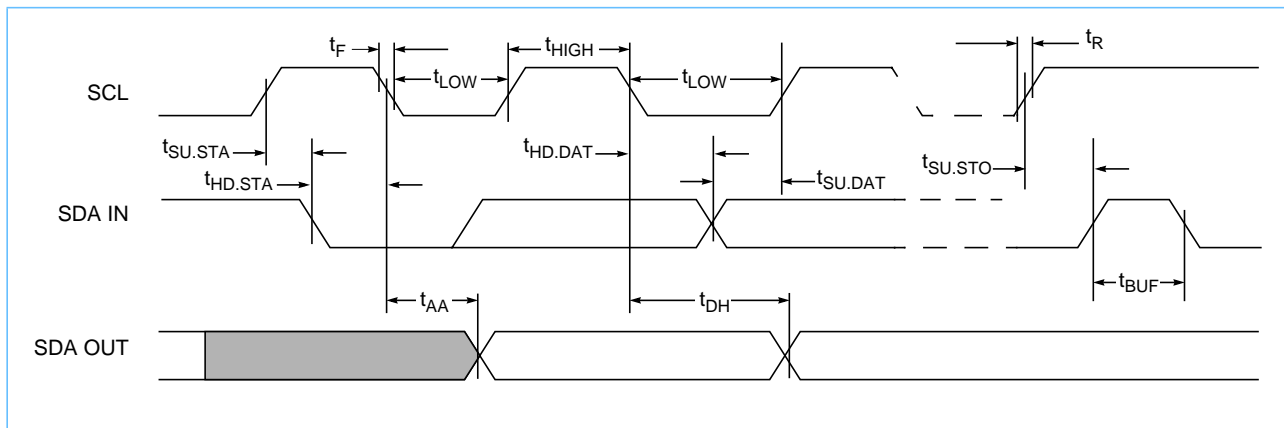

Fibre Channel GBIC

Absolute Maximum Ratings

Parameter	Symbol	Min	Typical	Max	Units	Notes
Storage Temperature	T _S	-40		75	°C	1
Relative Humidity–Storage	RH _S	0		95	%	1, 2
Ambient Operating Temperature	T _{OP}	-10		70	°C	1
Relative Humidity Operating	RH _{OP}	8		80	%	1, 2
Supply Voltage	V _{CC}	-0.5		6.0	V	1
TTL DC Input Voltage	V _I	0		V _{CC} + 0.7	V	1

1. Stresses listed may be applied one at a time without causing permanent damage. Functionality at or above the values listed is not implied. Exposure to these values for extended periods may affect reliability.
 2. Non-condensing environment.

Specified Operating Conditions

Parameter	Symbol	Min	Typical	Max	Units	Notes
Ambient Operating Temperature	T _{OP}	0		60	°C	1
Supply Voltage	V _{DDT} , V _{DDR}	4.75	5.0	5.25	V	
Relative Humidity Operating	RH _{OP}	8		80	%	2

1. Ambient air temperature across the GBIC. See Thermal Characteristics on page 20 for details.
 2. Non-condensing environment.

Electrical Characteristics - Power Supply

Parameter	Symbol	Min	Typical	Max	Units	Notes
Current (@ 5.0V)	I		160		mA	
Current (@ 5.25V)	I			300	mA	
Surge Current	I _{SURGE}			30	mA	1
Ripple & Noise				100	mV(pk-pk)	

1. Hot plug, above actual steady state current.

Transmit Signal Interface from host to GBIC

Parameter	Symbol	Min	Max	Units	Notes
PECL Amplitude	V_o	400	2000	mV	1
PECL Deterministic Jitter	$DJ_{elec-xmit}$		113	ps	2
PECL Total Jitter	$TJ_{elec-xmt}$		235	ps	2
PECL Rise/Fall		100	350	ps	3
PECL differential skew			20	ps	

1. At 150Ω, differential, pk-pk. The figure below shows the simplified circuit schematic for the GBIC high-speed differential input lines.

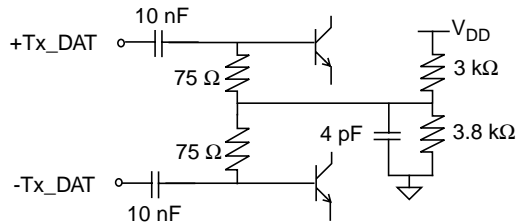

- Deterministic jitter (DJ) and total jitter (TJ) values are measured according to those defined in the Fibre-Channel Jitter Methodology Technical Report.
- Rise and fall times are measured from 20 to 80%, with a 150 Ohm differential termination.

Receive Signal Interface from GBIC to host

Parameter	Symbol	Min	Max	Units	Notes
PECL Amplitude	V_o	800	1600	mV	1
PECL Deterministic Jitter	$DJ_{elec-rcv}$		339	ps	2
PECL Total Jitter	$TJ_{elec-rcv}$		574	ps	2

1. At 150Ω, differential, pk-pk. The figure below shows the simplified circuit schematic for the GBIC high-speed differential output lines.

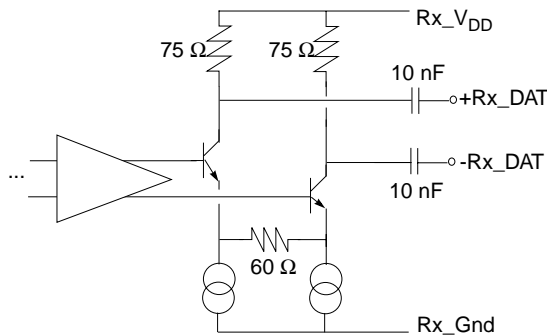

- Deterministic jitter (DJ) and total jitter (TJ) values are measured according to those defined in Fibre-Channel Jitter Methodology Technical Report. Jitter values at the output assume worst case jitter values at its input.

Fibre Channel GBIC

Control Electrical Interface

Parameter	Symbol	Min	Max	Units	Notes
Voltage Levels					
TTL Output)	V _{OL}	0.0	0.50	V	1
	V _{OH}	host_V _{CC} - 0.5	host_V _{CC} + 0.3	V	
TTL Input	V _{IL}	0	0.8	V	2
	V _{IH}	2.0	V _{DDT} + 0.3	V	
Serial ID SCL and SDA lines	V _{IL}		V _{DDT} x 0.3	V	1
	V _{IH}	V _{DDT} x 0.7	V _{DDT} + 0.5	V	
Timing Characteristics					
Tx_Disable (assert time)	t _{off}		10	µs	3
Tx_Disable (de-assert time)	t _{on}		1	ms	3
Tx_Disable (time to start reset)	t _{reset}	10		µs	3
Initialization Time (Tx_Fault)	t _{init}		300	ms	4
Tx_Fault Assert Delay	t _{fault}		100	µs	5
Rx_LOS Assert Delay	t _{loss_on}		100	µs	6
Rx_LOS De-Assert Delay	t _{loss_off}		100	µs	6
<ol style="list-style-type: none"> 1. A 4.7-10 kΩ pull-up resistor to V_{DDT} is required. 2. A 10 kΩ pull-up resistor to V_{DDT} is present on the GBIC (-1mA max). 3. See "Tx_Disable" on page 7. 4. See "Resetting a Fault (Tx_Fault)" on page 8. 5. See "Tx_Fault" on page 6 and "Tx_Disable" on page 7 for additional timing information. 6. See "Rx_LOS" on page 6 for timing relations. 					

Optical Characteristics Short Wavelength

Parameter	Symbol	Min	Typical	Max	Units	Notes
Transmitter Specifications						
Spectral Center Wavelength	λ_C	830		860	nm	
Spectral Width	$\Delta\lambda$			1.0	nm(rms)	
Launched Optical Power	PT	-10.0		-4.0	dBm(avg)	1
Optical Modulation Amplitude	OMA	0.156			mW	6
Optical Rise/Fall Time	T_{rise}/T_{fall}			300	ps	2
Relative Intensity Noise	RIN_{12}			-116	dB/Hz	3
Eye Opening		536			ps	4
Deterministic Jitter	DJ			198	ps	5
Receiver Specifications						
Operating Wavelength	λ	770		860	nm	
Optical Modulation Amplitude		31		2000	μ W (pk-pk)	6
Return Loss of Receiver	RL	12			dB	
Rx_LOS Assert Level	P_{off}	-27.0		-17.5	dBm(avg)	7
Rx_LOS De-Assert (negate) Level	P_{on}			-17.0	dBm(avg)	7
Rx_LOS Hysteresis			1.0		dB(optical)	7
Please see Notes for Short Wavelength Optical Characteristics on page 16.						

Fibre Channel GBIC

Notes for Short Wavelength Optical Characteristics

1. Launched optical power is measured at the end of a two meter section of a 50/125 μm fiber for the shortwave GBICs, and a 9/125 μm fiber for the longwave GBICs. The maximum and minimum of the allowed range of average transmitter power coupled into the fiber are worst case values to account for manufacturing variances, drift due to temperature variations, and aging effects.
2. Optical rise and fall time specifications are based on the unfiltered waveforms. For the purpose of standardizing the measurement method, measured waveforms shall conform to the mask as defined in PC-PI figure 16: Transmitter eye diagram mask. If a filter is needed to conform to the mask, the filter response effect should be removed from the measured rise and fall times using the equation: $T_{\text{RISE/FALL}} = [(T_{\text{RISE/FALL_MEASURED}})^2 - (T_{\text{RISE/FALL_FILTER}})^2]^{1/2}$. The optical signal may have different rise and fall times. Any filter should have an impulse response equivalent to a fourth order Bessel-Thomson Filter.
3. RIN_{12} is the laser noise, integrated over a specified bandwidth, measured relative to average optical power with 12 dB return loss. See ANSI Fibre Channel Specification Annex A.5.
4. Eye opening is the portion of the bit time where the bit error rate (BER) is $\leq 10^{-12}$. The general laser transmitter pulse shape characteristics are specified in the form of a mask of the transmitter eye diagram. These characteristics include pulse overshoot, pulse undershoot, and ringing, all of which should be controlled to prevent excessive degradation of the receiver sensitivity. When assessing the transmit signal, it is important to consider not only the eye opening, but also the overshoot and undershoot limitations.
5. Deterministic Jitter is measured as the peak-to-peak timing variation of the 50% optical signal crossings when transmitting repetitive K28.5 characters. It is defined in FC-PH, version 4.3, clause 3.1.87 as:
Timing distortions caused by normal circuit effects in the transmission system. Deterministic jitter is often subdivided into duty cycle distortion (DCD) caused by propagation differences between the two transitions of a signal and data dependent jitter (DDJ) caused by the interaction of the limited bandwidth of the transmission system components and the symbol sequence.
6. The Optical Modulation Amplitude (OMA) is defined as the difference in optical power between a logic level one and a logic level zero.
7. The Rx_LOS has hysteresis to minimize "chatter" on the output line. In principle, hysteresis alone does not guarantee chatter-free operation. These GBICs, however, present an Rx_LOS line without chatter, where chatter is defined as a transient response having a voltage level of greater than 0.5 volts (in the case of going from the negate level to the assert level) and of any duration that can be sensed by the host logic.

Optical Characteristics Long Wavelength

Parameter	Symbol	Min	Typical	Max	Units	Notes
Transmitter Specifications						
Spectral Center Wavelength	λ_C	1290		1340	nm	
Spectral Width	$\Delta\lambda$			2.5	nm(rms)	
Launched Optical Power	PT	-9.5		-3.0	dBm(avg)	1
Optical Modulation Amplitude	OMA	175			μ W (pk-pk)	6
Relative Intensity Noise	RIN ₁₂			-116	dB/Hz	2
Eye Opening		536			ps	3
Deterministic Jitter	DJ			198	ps	4
Optical Rise/Fall Time	T _{rise} /T _{fall}			320	ps	5
Receiver Specifications						
Operating Wavelength	λ	1270		1355	nm	
Optical Modulation Amplitude	OMA	15		1000	μ W (pk-pk)	6
Return Loss of Receiver	RL	12			dB	
Rx_LOS Assert Level	P _{off}	-30.0		-20.5	dBm(avg)	7
Rx_LOS De-Assert (negate) Level	P _{on}			-20.0	dBm(avg)	7
Rx_LOS Hysteresis			2.0		dB(optical)	7
Please see Notes for Long Wavelength Optical Characteristics on page 18.						

Fibre Channel GBIC

Notes for Long Wavelength Optical Characteristics

1. Launched optical power is measured at the end of a two meter section of a 50/125 μm fiber for the shortwave GBICs and a 9/125 μm fiber for the longwave GBICs). The maximum and minimum of the allowed range of average transmitter power coupled into the fiber are worst case values to account for manufacturing variances, drift due to temperature variations, and aging effects.
2. RIN_{12} is the laser noise, integrated over a specified bandwidth, measured relative to average optical power with 12 dB return loss. See ANSI Fibre Channel Specification Annex A.5.
3. Eye opening is the portion of the bit time where the bit error rate (BER) is $\leq 10^{-12}$. The general laser transmitter pulse shape characteristics are specified in the form of a mask of the transmitter eye diagram. These characteristics include pulse overshoot, pulse undershoot, and ringing, all of which should be controlled to prevent excessive degradation of the receiver sensitivity. When assessing the transmit signal, it is important to consider not only the eye opening, but also the overshoot and undershoot limitations.
4. Deterministic Jitter is measured as the peak-to-peak timing variation of the 50% optical signal crossings when transmitting repetitive K28.5 characters. It is defined in FC-PH, version 4.3, clause 3.1.87 as:
Timing distortions caused by normal circuit effects in the transmission system. Deterministic jitter is often subdivided into duty cycle distortion (DCD) caused by propagation differences between the two transitions of a signal and data dependent jitter (DDJ) caused by the interaction of the limited bandwidth of the transmission system components and the symbol sequence.
5. Optical rise and fall time specifications are based on the unfiltered waveforms. For the purpose of standardizing the measurement method, measured waveforms shall conform to the mask as defined in PC-PI figure 16: Transmitter eye diagram mask. If a filter is needed to conform to the mask, the filter response effect should be removed from the measured rise and fall times using the equation: $T_{\text{RISE/FALL}} = [(T_{\text{RISE/FALL_MEASURED}})^2 - (T_{\text{RISE/FALL_FILTER}})^2]^{1/2}$ The optical signal may have different rise and fall times. Any filter should have an impulse response equivalent to a fourth order Bessel-Thomson Filter.
6. The Optical Modulation Amplitude (OMA) is defined as the difference in optical power between a logic level one and a logic level zero.
7. The Rx_LOS has hysteresis to minimize "chatter" on the output line. In principle, hysteresis alone does not guarantee chatter-free operation. These GBICs, however, present an Rx_LOS line without chatter, where chatter is defined as a transient response having a voltage level of greater than 0.5 volts (in the case of going from the negate level to the assert level) and of any duration that can be sensed by the host logic.

Optical Cable/Connector

Parameter	Symbol	Min	Typical	Max	Unit	Notes
9/125µm Cable Specifications (Single mode 1310nm)						
Length for longwave GBICs	L	2		10,000	m	
Attenuation @ $\lambda = 1310\text{nm}$	μ_c			0.5	dB/km	
SC Optical Connector (Single mode)						
Nominal Attenuation	μ_{con}		0.3	0.5	dB	1
Attenuation Standard Deviation	σ_{con}		0.1		dB	1
Connects/Disconnects				250	cycles	1
50/125µm Cable Specifications (Multimode 850nm, 400MHz•km)						
Length for shortwave GBICs	L	2		500	m	
Bandwidth @ $\lambda = 850\text{nm}$	BW	400			MHz•km	
Attenuation @ $\lambda = 850\text{nm}$	μ_c			3.5	dB/km	
Numerical Aperture	N.A.		0.20			
50/125µm Cable Specifications (Multimode 850nm, 500MHz•km)						
Length for shortwave GBICs	L	2		550	m	
Bandwidth @ $\lambda = 850\text{nm}$	BW	500			MHz•km	
Attenuation @ $\lambda = 850\text{nm}$	μ_c			3.5	dB/km	
Numerical Aperture	N.A.		0.20			
62.5/125µm Cable Specifications (Multimode 850nm, 160MHz•km)						
Length for shortwave GBICs	L	2		250	m	
Bandwidth @ $\lambda = 850\text{nm}$	BW	160			MHz•km	
Attenuation @ $\lambda = 850\text{nm}$	μ_c			3.75	dB/km	
Numerical Aperture	N.A.		0.275			
62.5/125µm Cable Specifications (Multimode 850nm, 200MHz•km)						
Length for shortwave GBICs	L	2		300	m	
Bandwidth @ $\lambda = 850\text{nm}$	BW	200			MHz•km	
Attenuation @ $\lambda = 850\text{nm}$	μ_c			3.75	dB/km	
Numerical Aperture	N.A.		0.275			
SC Optical Connector (Multimode)						
Nominal Attenuation	μ_{con}		0.3	0.5	dB	1
Attenuation Standard Deviation	σ_{con}		0.2		dB	1
Connects/Disconnects				250	cycles	1
1. The optical interface connector dimensionally conforms to the industry standard SC type connector documented in JIS-5973. A dual keyed SC receptacle serves to align the optical transmission fiber mechanically to the shortwave GBICs. See Duplex SC Receptacle on page 26 for a drawing of the duplex SC receptacle that is part of the shortwave GBICs.						

Fibre Channel GBIC

Thermal Characteristics

Airflow (lfm)	Maximum Local Temperature (°C)	Notes
0	58	1
100	61	1
200	62	1
300	64	1

1. To meet the specified operating temperature, the ambient temperature of the air moving over the shortwave GBICs, and also the longwave GBICs should not exceed these values.

Reliability Projections

Parameter	Symbol	Min	Typical	Max	Units	Notes
Average Failure Rate - shortwave GBICs	AFR			0.0195	%/khr	1
Average Failure Rate - longwave GBICs	AFR			0.0195	%/khr	1

1. AFR specified over 44 khours at 45°C.

Serial ID Timing Specifications GBICs with Serial ID only

Parameter	Symbol	Min	Typical	Max	Units	Notes
Clock Frequency	f _{SID}			100	kHz	1
Clock Pulse Width Low	t _{LOW}	1.2			µs	1
Clock Pulse Width High	t _{HIGH}	0.6			µs	1
Clock Low to Data Out Valid	t _{AA}	0.1		0.9	µs	1
Time the data line must be free before a new transmission can start	t _{BUF}	1.2			µs	1
Start Hold Time	t _{HD.STA}	0.6			µs	1
Start Set-up Time	t _{SU.STA}	0.6			µs	1
Data In Hold Time	t _{HD.DAT}	0			µs	1
Data In Set-up Time	t _{SU.DAT}	100			ns	1
Inputs Rise Time	t _R			0.3	µs	1
Inputs Fall Time	t _F			300	ns	1
Stop Set-up Time	t _{SU.STO}	0.6			µs	1
Data Out Hold Time	t _{DH}	50			ns	1

1. See Serial ID Figure 4 on page 11 for timing relationships. See Serial Module Definition Protocol (Serial ID) on page 10 and Serial ID Data and Descriptions on page 21 for more information on Serial ID implementation.

Serial ID Data and Descriptions

The Serial ID tables on the following pages contain specific information about the data contained within the Serial ID EEPROM. EEPROM. Tables 5 and 6 list actual Serial ID Data for the shortwave and longwave products, respectively.

All ID information is stored in eight-bit parameters addressed from 00h to 7Fh. All numeric information fields have the lowest address in the memory space storing the highest order byte. The highest order bit is always transmitted first. All numeric fields will be padded on the left with zeros. All character strings are ordered with the first character to be displayed located in the lowest address of the memory space. All character strings will be padded on the right with ASCII spaces (20h) to fill empty bytes.

Check Codes

The check codes contained within the identification data are one byte codes that can be used to verify that the data in previous addresses is valid. CCID check code is the lower eight bits of the sum of the contents of bytes 0-62. CCEX check code is the lower eight bits of the sum of the contents of bytes 64-94.

Fibre Channel GBIC

Serial ID Table 5 Serial ID Data Entries for Shortwave GBICs with Serial ID

Data Address	Length (Bytes)	Name of Field	Data to be Included in the Field for SW
Base ID Fields			
0	1	Identifier	01h = GBIC
1	1	Reserved	00h
2	1	Connector	01h = SC Optical Connector
3-10	8	Transceiver	00000000000000000000000000000000100000010000000000110000000001 = 100-M5/M6-SN-I (Fibre Channel Compliance code for Optical Compatibility)
11	1	Encoding	01h = 8B10B Encoding
12	1	BR, Nominal	0Bh = 100 Mb/s x 11 = 1.1 Gb/s
13-14	2	Reserved	0000h
15	1	9μ, Distance	00h = Single Mode Fiber is not supported
16	1	50μ, Distance	32h = 50 x 10 m = 500 m on 50/125 μm fiber
17	1	60μ, Distance	16h = 22 x 10 m = 220 m on 62.5/125 μm fiber
18	1	CU, Distance	00h = Copper is not supported
19	1	Reserved	00h
20-35	16	Vendor name	"JDS Uniphase " (ASCII)
36-39	4	Vendor OUI	00019Ch = JDS Uniphase OUI
40-55	16	Vendor PN	"xxxxxxxxxxxxxxx" = part number (ASCII)
56-59	4	Vendor rev	"xx" = number (ASCII)
60-62	3	Reserved	000000h
63	1	CCID	Least significant byte of sum of data in addresses 0-62
Extended ID Fields			
64-65	2	Options	000000000011010 = LOS, TX_Fault, TX_Disable all supported
66	1	BR, max	05h = 5% Upper baud rate margin
67	1	BR, min	05h = 5% Lower baud rate margin
68-83	16	Vendor SN	"xxxxxxxxxxxxxxx" = serial number (ASCII)
84-91	8	Date code	"xxxxxxx" = date code (ASCII ' yymmddll' yy=year mm=month dd=day ll=lot number (yy=00 is year 2000))
92-94	3	Reserved	000000h
95	1	CCEX	Least significant byte of sum of data in addresses 64-94
Specific ID Field			
96-127	32	Readable	"GBICS ARE CLASS 1 LASER SAFE" (ASCII)

Serial ID Table 6 Serial ID Data Entries for JGB-10LYAA1

Data Address	Length (Bytes)	Name of Field	Data to be Included in the Field for LW
Base ID Fields			
0	1	Identifier	01h = GBIC
1	1	Reserved	00h
2	1	Connector	01h = SC Optical Connector
3-10	8	Transceiver	00000000000000000000000000000000100100000000000000100000001 = 100-SM-LC-L (Fibre Channel Compliance code for Optical Compatibility)
11	1	Encoding	01h = 8b10b Encoding
12	1	BR, Nominal	0Bh = 100 Mb/s x 11 = 1.1 Gb/s
13-14	2	Reserved	0000h
15	1	9μ, Distance	64h = 100 x 100 m = 10 km on single mode fiber
16	1	50μ, Distance	00h = Not supported
17	1	60μ, Distance	00h = Not Supported
18	1	CU, Distance	00h = Copper is not supported
19	1	Reserved	00h
20-35	16	Vendor name	"JDS Uniphase" (ASCII)
36-39	4	Vendor OUI	00019Ch
40-55	16	Vendor PN	"xxxxxxxxxxxxxxx" = part number (ASCII)
56-59	4	Vendor rev	"xx" = revision number (ASCII)
60-62	3	Reserved	000000h
63	1	CCID	Least significant byte of sum of data in addresses 0-62
Extended ID Fields			
64-65	2	Options	000000000011010 = LOS, TX_Fault, TX_Disable all supported
66	1	BR, max	05h = 5% Upper baud rate margin
67	1	BR, min	05h = 5% Lower baud rate margin
68-83	16	Vendor SN	"xxxxxxxxxxxxxxx" = serial number (ASCII)
84-91	8	Date code	"xxxxxxx" = date code (ASCII ' yymmddll' yy=year mm=month dd=day ll=lot number (yy=00 is year 2000))
92-94	3	Reserved	000000h
95	1	CCEX	Least significant byte of sum of data in addresses 64-94
Specific ID Field			
96-127	32	Readable	"GBICS ARE CLASS 1 LASER SAFE" (ASCII)

Fibre Channel GBIC

Mechanical Description

Mechanical Outline

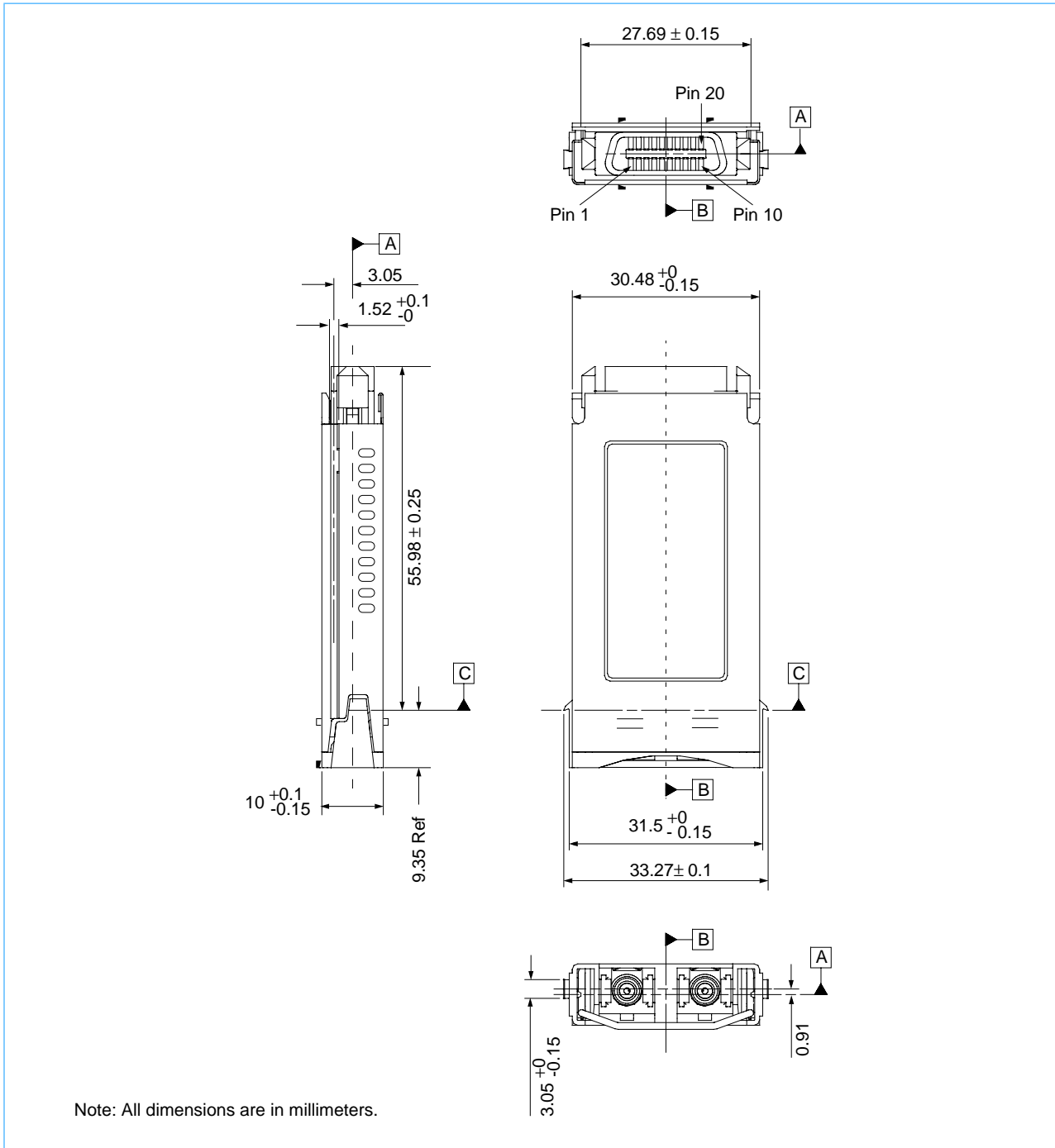

Two optical receptacles are at the end of the module. They are spaced 12.7 mm apart to accept a standard duplex SC connector.

System Board Considerations

The GBICs are intended to be used on a host card having a nominal thickness of 0.062" or 0.100" (see below for mating connector options). The host card footprint with essential keepouts and drill holes is shown on page 27.

Connector Availability

The connector used by these GBICs is a 20-pin model of the AMP SCA-2 connector. The following part numbers are available to provide mating connections:

Description	Part Number
Vertical receptacle, placed on a backplane for connection of shortwave GBICs perpendicular to the surface of the backplane	AMP 787646-1
Right angle receptacle, placed on motherboard for connection of shortwave GBICs parallel to the surface of the backplane as a daughter board	AMP 787653-1
Guide system for PCB of thickness 0.062" \pm 0.008	AMP 787663-3
Guide system for PCB of thickness 0.100" \pm 0.008	AMP 787663-4

Fibre Channel GBIC

Duplex SC Receptacle

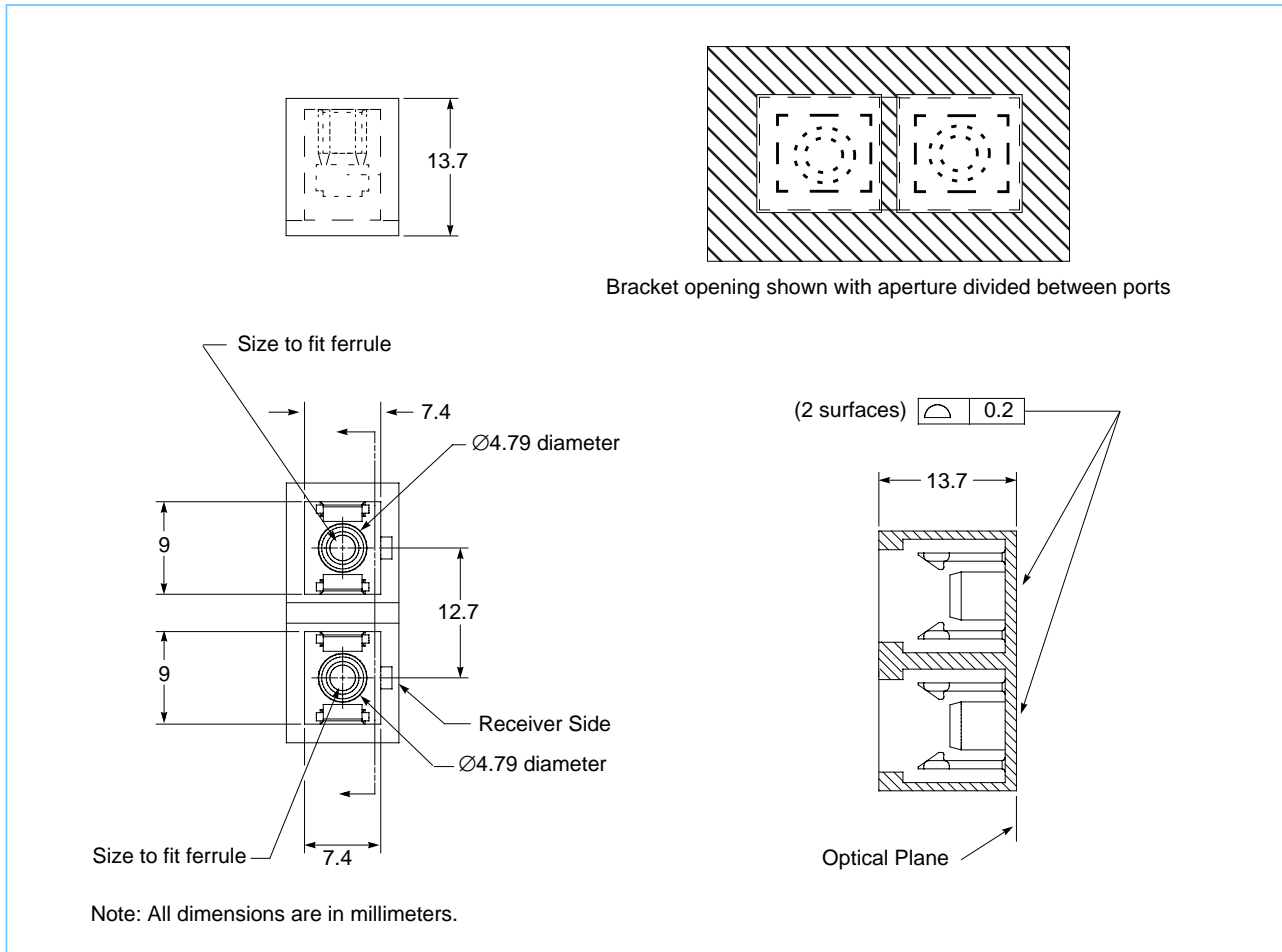

Host Card Footprint

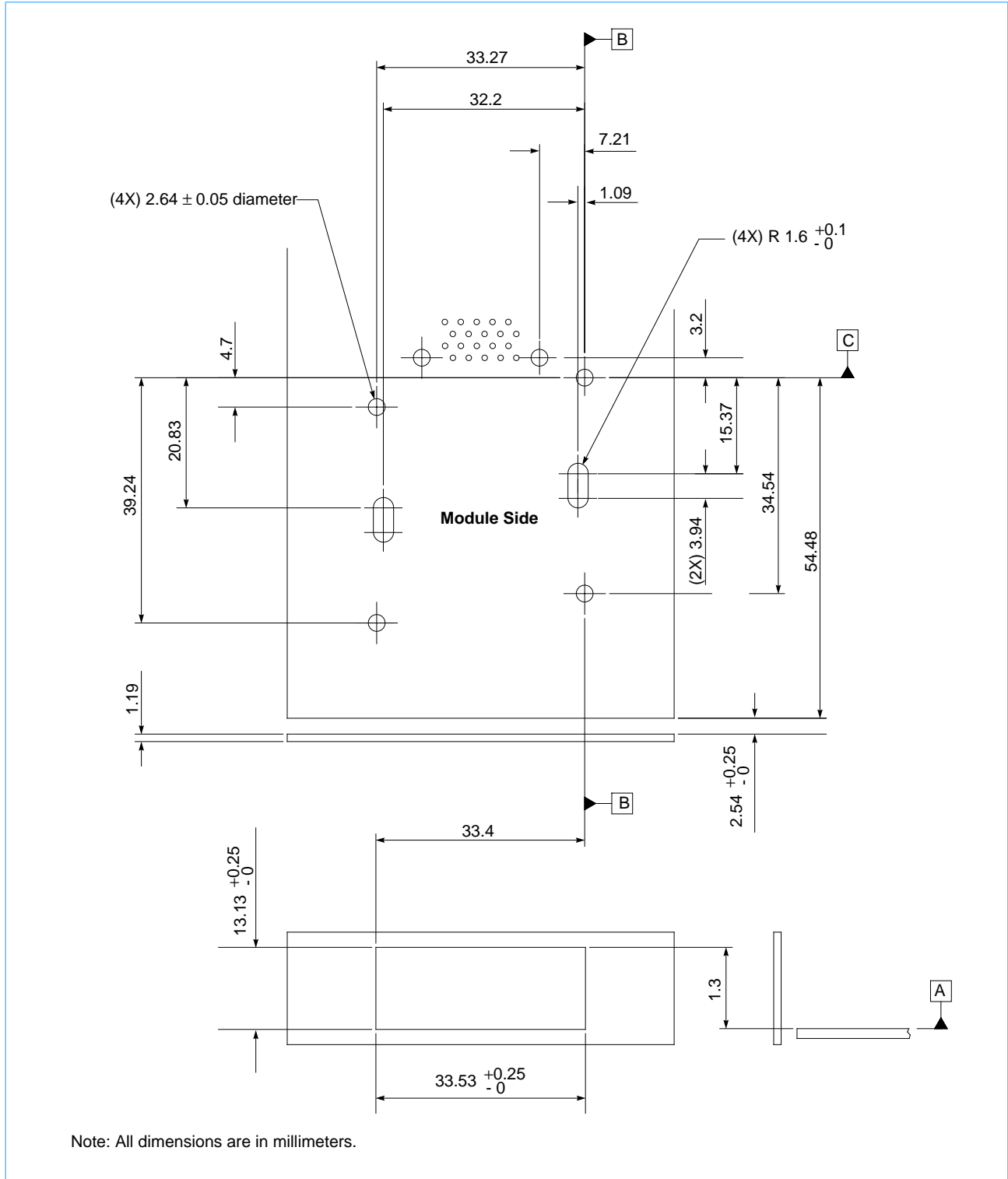

Fibre Channel GBIC

References

Standards

1. American National Standards Institute Inc. (ANSI), T11, Fibre Channel-Physical and Signaling Interface (FC-PI Rev. 10.1). Copies of this document may be purchased from:
Global Engineering
15 Inverness Way East
Englewood, CO 80112-5704
Phone: (800) 854-7179 or (303) 792-2181
Fax: (303) 792-2192.

Industry Specifications

2. Gigabit Interface Converter specification, Revision 5.4 (GBIC V5.4). This document may be downloaded under anonymous ftp from: playground.sun.com. It is in the directory pub/OEmod.
3. A.X. Widmer and P.A. Franaszek, "A DC-Balanced, Partitioned-Block, 8B/10B Transmission Code," *IBM Journal of Research and Development*, vol. 27, no. 5, pp. 440-451, September 1983. This paper fully defines the 8B/10B code. It is primarily theoretical.
4. A.X. Widmer, The ANSI Fibre Channel Transmission Code, *IBM Research Report, RC 18855 (82405)*, April, 23 1993. Copies may be requested from:
Publications
IBM Thomas J. Watson Research Center
Post Office Box 218
Yorktown Heights, New York 10598
Phone: (914) 945-1259
Fax: (914) 945-4144

Revision Log

Rev	Contents of Modification												
3/97	Draft 0.0 release of specification.												
9/97	Production release level of specification.												
9/09/98	Reformatted entire document. Initial release.												
11/09/98	First Revision (01). Changed document name from SOC_1063N+1250N to GBIC. Changed all occurrences of "SOC" to "GBIC."												
4/27/99	Second Revision (02). Updated mechanical drawing to show stop. Replaced TBD in Reliability Projections on page 20. Updated maximum Operating Temperature in Specified Operating Conditions on page 12. Updated Air-flow and Maximum Local Temperature values in Thermal Characteristics on page 20. Deleted two 1250MBd, no serial ID products: <table border="0" style="margin-left: 20px;"> <tr> <td>IBM42S12SNAA20</td> <td>GBIC-1250N</td> <td>(short wave)</td> </tr> <tr> <td>IBM42S12LNAA20</td> <td>GBIC-1250N-LW</td> <td>(long wave)</td> </tr> </table> Added two 1063MBd, serial ID products: <table border="0" style="margin-left: 20px;"> <tr> <td>IBM42S10SNYAA20</td> <td>GBIC-1063NS</td> <td>(short wave)</td> </tr> <tr> <td>IBM42S10LNYAA20</td> <td>GBIC-1063NS-LW</td> <td>(long wave)</td> </tr> </table>	IBM42S12SNAA20	GBIC-1250N	(short wave)	IBM42S12LNAA20	GBIC-1250N-LW	(long wave)	IBM42S10SNYAA20	GBIC-1063NS	(short wave)	IBM42S10LNYAA20	GBIC-1063NS-LW	(long wave)
IBM42S12SNAA20	GBIC-1250N	(short wave)											
IBM42S12LNAA20	GBIC-1250N-LW	(long wave)											
IBM42S10SNYAA20	GBIC-1063NS	(short wave)											
IBM42S10LNYAA20	GBIC-1063NS-LW	(long wave)											
03/06/02	Changed to JDS Uniphase specification New Serial ID data Optical Specifications matched to the Fibre Channel Specification												



© JDS Uniphase Corporation 2002

Printed in the United States of America, April 2002

All statements, technical information and recommendations related to the products herein are based upon information believed to be reliable or accurate. However, the accuracy or completeness thereof is not guaranteed, and no responsibility is assumed for any inaccuracies. The user assumes all risks and liability whatsoever in connection with the use of a product or its application. JDS Uniphase reserves the right to change at any time without notice the design, specifications, function, fit or form of its products described herein, including withdrawal at any time of a product offered for sale herein. JDS Uniphase makes no representations that the products herein are free from any intellectual property claims of others. Please contact JDS Uniphase for more information. JDS Uniphase and the JDS Uniphase logo are trademarks of JDS Uniphase Corporation. Other trademarks are the property of their respective holders. Copyright JDS Uniphase Corporation. All rights reserved.

The JDS Uniphase home page can be found at <http://www.jdsu.com>

GBIC.fc



Artisan Technology Group is your source for quality new and certified-used/pre-owned equipment

- FAST SHIPPING AND DELIVERY
- TENS OF THOUSANDS OF IN-STOCK ITEMS
- EQUIPMENT DEMOS
- HUNDREDS OF MANUFACTURERS SUPPORTED
- LEASING/MONTHLY RENTALS
- ITAR CERTIFIED SECURE ASSET SOLUTIONS

SERVICE CENTER REPAIRS

Experienced engineers and technicians on staff at our full-service, in-house repair center

*InstraView*SM REMOTE INSPECTION

Remotely inspect equipment before purchasing with our interactive website at www.instraview.com ↗

WE BUY USED EQUIPMENT

Sell your excess, underutilized, and idle used equipment. We also offer credit for buy-backs and trade-ins. www.artisanng.com/WeBuyEquipment ↗

LOOKING FOR MORE INFORMATION?

Visit us on the web at www.artisanng.com ↗ for more information on price quotations, drivers, technical specifications, manuals, and documentation

Contact us: (888) 88-SOURCE | sales@artisanng.com | www.artisanng.com