



Artisan Technology Group is your source for quality new and certified-used/pre-owned equipment

- FAST SHIPPING AND DELIVERY
- TENS OF THOUSANDS OF IN-STOCK ITEMS
- EQUIPMENT DEMOS
- HUNDREDS OF MANUFACTURERS SUPPORTED
- LEASING/MONTHLY RENTALS
- ITAR CERTIFIED SECURE ASSET SOLUTIONS

SERVICE CENTER REPAIRS

Experienced engineers and technicians on staff at our full-service, in-house repair center

*InstraView*SM REMOTE INSPECTION

Remotely inspect equipment before purchasing with our interactive website at www.instraview.com ↗

WE BUY USED EQUIPMENT

Sell your excess, underutilized, and idle used equipment. We also offer credit for buy-backs and trade-ins. www.artisanng.com/WeBuyEquipment ↗

LOOKING FOR MORE INFORMATION?

Visit us on the web at www.artisanng.com ↗ for more information on price quotations, drivers, technical specifications, manuals, and documentation

Contact us: (888) 88-SOURCE | sales@artisanng.com | www.artisanng.com

INTRODUCTION

This reference and programming guide contains condensed specifications, descriptions of various features and information for operating the Model 196. Also included are programming examples using various controllers.

© 1986, Keithley Instruments, Inc.
Instrument Division
Cleveland, Ohio, U.S.A.
Document Number 196-903-01 Rev. A

TABLE OF CONTENTS

CONDENSED SPECIFICATIONS	3
MODEL 196 FEATURES	10-16
FRONT PANEL PROGRAMS	17-23
FRONT PANEL TRIGGERING	25-27
IEEE-488 PROGRAMMING	28-39
TRANSLATOR SOFTWARE	40-44
PROGRAMS	45
Data Store Operation Using HP-85	46
IBM PC or XT	47
Apple II	49
HP-85	51
HP-9816	53
HP-9825A	55
DEC LSI 11	57
PET/CBM 2001	59

CONDENSED SPECIFICATIONS

DC VOLTS

Range	6½-Digit Accuracy ±(%rdg + counts) 1 Year, 18 -28°C
300mV	0.008 + 20 ¹
3 V	0.0038 + 20
30 V	0.008 + 30
300 V	0.009 + 30

¹When properly zeroed.

TRMS AC VOLTS

Range	5½-Digit Accuracy ±(% rdg + counts) 1 Year, 18° -28°C ¹				
	20Hz- 50Hz ¹	50Hz- 200Hz ¹	200Hz- 10kHz ²	10kHz- 20kHz ²	20kHz- 100kHz ²
300mV	2+100	0.3+100	0.15+100	0.4+200	2.0+300
3 V	2+100	0.3+100	0.15+100	0.3+200	1.5+300
30 V	2+100	0.3+100	0.15+100	0.4+200	1.5+300
300 V	2+100	0.3+100	0.15+100	0.4+200	1.5+300

¹Sinewave inputs above 2000 counts

²Sinewave inputs above 20,000 counts.

NON-SINUSODIAL INPUTS: For fundamental frequencies <1kHz, crest factor <3, add 0.25% of reading to specified accuracy for 300mV and 3V ranges; add 0.6% of reading to specified accuracy for 30V and 300V ranges.

INPUT IMPEDANCE: 1MΩ shunted by <120pF.

3dB BANDWIDTH: 300kHz typical.

RESPONSE: True root mean square, ac coupled

dB (Ref. = 1V)

Input	Accuracy \pm dB 1 Year, 18° -28°C	
	20Hz-20kHz	20kHz-100kHz
-34 to 49dB (20mV to 300V)	0.2	0.4
-54 to -34dB (2mV to 20mV)	1.1	3 ¹

¹ Typical

OHMS

Range	6½-Digit Accuracy \pm (%rdg + counts) 1 Year, 18° -28°C
300 Ω ¹	0.010 + 20 ²
3 k Ω ¹	0.007 + 20
30 k Ω ¹	0.007 + 20
300 k Ω	0.021 + 20
3M Ω	0.021 + 20
30M Ω	0.1 + 50
300M Ω ³	2.0 + 5

¹4-terminal accuracy, 300 Ω -30k Ω range.

² When properly zeroed.

³ Resolution on 300M Ω range is limited to 5½-digits.

CONFIGURATION: Automatic 2- or 4-wire. Offset compensation available on 300 Ω -30k Ω ranges. Allowable compensation of \pm 10mV on 300 Ω range and \pm 100mV on 3k Ω and 30k Ω ranges.

OPEN CIRCUIT VOLTAGE: 5.5V maximum.

DC AMPS

Range	5½-Digit Accuracy ±(%rdg + counts) 1 Year, 18° -28°C		Maximum Voltage Burden
	300 μ A	0.09 + 20	0.4V
3mA	0.05 + 10	0.4V	
30mA	0.05 + 10	0.4V	
300mA	0.05 + 10	0.5V	
3 A	0.09 + 10	2 V	

TRMS AC AMPS

Range	5½-Digit Accuracy ±(%rdg + counts) 1 Year, 18° -28°C		Maximum Voltage Burden
	20Hz-45Hz	45Hz-10kHz	
300 μ A	2 + 100	0.9 + 100	0.4V
3mA	2 + 100	0.6 + 100	0.4V
30mA	2 + 100	0.6 + 100	0.4V
300mA	2 + 100	0.6 + 100	0.5V
3 A	2 + 100	0.6 + 100	2 V

¹For sinewave inputs above 2000 counts

RESPONSE: True root mean square, AC coupled.

NON-SINUSODIAL INPUTS: Specified accuracy for fundamental frequencies <1kHz. CF <3, at ¾ full scale.

dB (Ref. = 1mA)

**Accuracy ±dB
1 Year, 18° -28°C**

Input	20Hz-10kHz	
	Off	On
-34 to +69dB (20 μ A to 3A)		0.2
-54 to -34dB (2 μ A to 20 μ A)		0.9

MAXIMUM READING RATES¹

DCV, DCA, ACV, ACA, Readings/Second

Resolution	Continuous into Internal Buffer		External Trigger into Internal Buffer		Triggered via IEEE-488 Bus	
	MUX:		MUX:		MUX:	
	Off	On	Off	On	Off	On
3½-Digit	1000	1000	237	80	112	58
4½-Digit	333	333	145	63	91	49
5½-Digit	35(29)	9(7.5)	40(33)	9(7.5)	35(29)	9(7.5)
6½-Digit ²		9(7.5)		0.3(0.25)		0.3(0.25)

OHMS Readings/Second

Resolution	Continuous into Internal Buffer		External Trigger into Internal Buffer		Triggered via IEEE-488 Bus	
	MUX:		MUX:		MUX:	
	Off	On	Off	On	Off	On
3½-Digit	53	25	57	25	37	23
4½-Digit	43	20	47	21	30	19
5½-Digit	16(13)	9.5(7.5)	18(15)	9.5(7.5)	15(12.5)	9.5(7.5)
6½-Digit ²		9(7.5)		0.3(0.25)		0.3(0.25)

Offset Compensated Ohms: Rates are $0.5 \times$ normal mux on ohms rates.

¹Reading rates are for on-range on-scale readings with internal filter off, for 3V, 3k Ω , and 3mA ranges. 6½- and 5½-digit rates are for 60Hz operation. Values in parenthesis are for 50Hz operation,

²Internal filter on.

SAFETY PRECAUTIONS

1. Before operation, ground the instrument through a properly earth grounded power receptacle.
2. Before servicing, disconnect the instrument from the power line and all other equipment, and consult the Model 196 Instruction Manual.
3. Do not touch any terminals while the instrument is turned on or connected to any other test equipment.

DISPLAY MESSAGES

Error Messages*

Message	Explanation
UNCAL	E ² PROM failure on power up. See manual, paragraph 6.7.2.
NO PROGRAM	Invalid entry while trying to select program.
OVERFLO KΩ	Overrange-Decimal point position and mnemonics define function and range (3kΩ range shown). The number of characters in the "OVERFLO" message defines the display resolution (6½d resolution shown).
TRIG-ERROR	Trigger received while still processing reading from last trigger.
AC ONLY	Selecting dB with instrument not in ACV or ACA.
NO RANGE	Pressing a range button while in ACV dB or ACA dB.
CONFLICT	196 in invalid state (i.e., dB function) when entering calibration program.

*These messages are associated with front panel operation. Messages associated with IEEE operation are located in the IEEE section of this guide.

INPUT SWITCH

The INPUT switch (located on rear panel) is used to select either front panel inputs or rear panel inputs. With the input switch released (out), the rear panel safety input jacks are selected. With the switch depressed (in), the front panel safety jacks are selected. Status of the switch position can be read over the IEEE-488 bus (see U8 status word).

RANGE GROUP

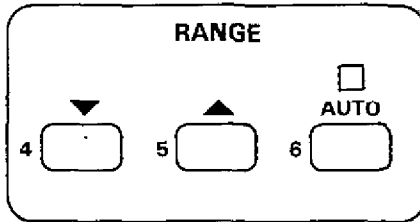

AUTO Range

Pressing the AUTO button places the Model 196 in autorange and turns on the AUTO indicator light.

Manual Range

Pressing the ▲ button causes the Model 196 to uprange. Pressing the ▼ button causes the instrument to downrange. Either button disables autoranging.

FUNCTION

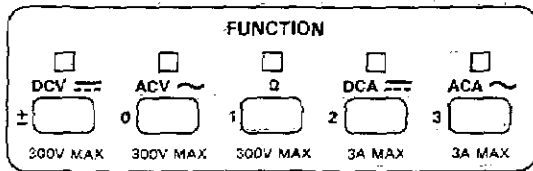

These buttons are used to select the DC volts (DCV), AC volts (ACV), Ohms (Ω), DC current (DCA), and AC current (ACA) functions.

Basic Measurements

1. Select a measurement function by pressing the appropriate button.
2. Select a range consistent with the expected input signal or use AUTO range.
3. Select front or rear panel inputs with the INPUT switch.
4. Use the ZERO button as needed to cancel offset voltages or lead resistances. This is recommended on the 300mV DC and 300 Ω ranges.
5. Connect the signal to be measured to the input terminals. Four-terminal measurements are recommended on the 300 Ω , 3k Ω and 30k Ω ranges.
6. Take the reading from the display.

Note: The current function is protected by a 3A fuse. It is accessible from the rear panel.

MODIFIERS

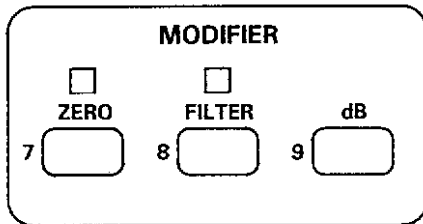

ZERO

The Zero feature serves as a means of zero correction or baseline suppression by allowing a stored offset value to be subtracted from subsequent readings. When the ZERO button is pressed, the instrument triggers a conversion and stores the reading as a zero value. Program ZERO allows the user to manually enter the zero value. All subsequent readings represent the differences between the applied signal level and the zero value. A zero value can be established for any or all measurement functions and is remembered by each function.

OPERATION

1. Select function and range.
2. Turn ZERO off if presently on.
3. Apply a short or baseline signal to the input.
4. Press the ZERO button. The display will read zero.
5. Disconnect the short or baseline signal and apply the signal to be measured.

FILTER

The digital filter attenuates excess noise present on input signals. The filter is a weighted average type. The factory default filter weighting is $1/10$ (filter value 10). Program FILTER allows the user to change filter weighting from 1 to $1/99$ (filter value 99). Each function can have its own unique filter value.

Each filtered measurement is first filtered for three time constants before being displayed. A time constant is measured in readings. The number of readings in one time constant is equal to the filter value. Thus, for a filter value of 10, three time constants is equal to 30 readings.

OPERATION

With Program FILTER, set to the desired filter value and press the FILTER button. The indicator will turn on and flash until a fully filtered reading is obtained.

dB

The dB button selects the dB measurement mode with the instrument in the ACV or ACA functions. When measuring in dB, it is possible to compress a wide range of measurements into a much smaller scope. The displayed reading is directly in dB. The relationship between dB and voltage/current can be expressed by the following equations:

$$\text{dB} = 20 \log \frac{|V_{in}|}{|V_{ref}|}$$

$$\text{dB} = 20 \log \frac{|I_{in}|}{|I_{ref}|}$$

where:

$$\begin{aligned} \text{Factory Default } V_{ref} &= 1\text{V} \\ I_{ref} &= 1\text{mA} \end{aligned}$$

From the above equation, it can be derived that 1V or 1mA at the input (V_{in} and I_{in}) will result in a 0dB reading on the Model 196.

There are two methods that can be used to change the reference value. One method is to use the zero feature. This consists of applying a signal to the instrument and pressing the ZERO button. The suppressed level is the dB reference (0dB point). An alternate method is to use Program dB to enter the desired reference value.

OPERATION

Operation consists of selecting ACV or ACA, changing (if desired) the dB reference, applying the signal to be measured, and pressing the dB button.

dBm Measurements:

dBm is decibels above or below a 1mW reference. Measurement in dBm can be referenced to impedance rather than voltage or current. Because the instrument cannot directly establish impedance references, an equivalent voltage must be calculated and established for a particular impedance reference. Use the following equation to calculate the equivalent voltage:

$$V_{ref} \text{ for OdBm} = \sqrt{(1\text{mW}) (Z_{ref})}$$

dBW Measurements:

dBW is decibels above or below a 1W reference. Measurements in dBW are made in the same manner as dBm measurements; that is, calculating and establishing the voltage reference for a particular impedance. Use the following equation to calculate the voltage reference:

$$V_{ref} \text{ for } 0\text{dBW} = \sqrt{Z_{ref}}$$

FRONT PANEL PROGRAMS

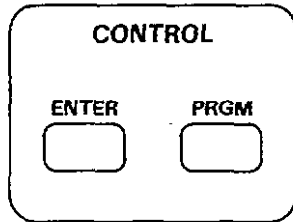

The CONTROL buttons (PRGM and ENTER), along with the data buttons (\pm , 0 through 9), are used to manipulate front panel programs.

Program	Description
0 (Menu)	Display software level and list available front panel programs.
2 (Resolution)	Change display resolution (3 ½ d, 4 ½ d, 5 ½ d or 6 ½ d).
4 (MX+B)	Enable MX+B program.
5 (HI/LO/Pass)	Enable/disable HI/LO/Pass program.
6 (Mux)	Recall status, enable/disable auto/cal multiplexer.
30 (Save)	Save current front panel setup.
31 (IEEE Address)	Recall/modify IEEE address.
32 (Line Frequency)	Recall/modify line frequency setting (50/60Hz).
33 (Self Test)	Enter self-test program.
34 (MX+B Parameters)	Recall/modify MX+B program value.
35 (HI/LO/ Limits)	Recall/modify HI/LO limits.
36 (Calibration)	Enter digital calibration mode.
37 (Reset)	Returns 196 to factory default conditions.
Ω	Recall status, enable/disable ohms compensation.
ZERO	Recall/modify zero value.
FILTER	Recall/modify filter value.
dB	Recall/modify dB reference value.

Program Selection

Program selection is accomplished by pressing the PRGM button followed by the button(s) that correspond to the program number or name. For example, to select Program 31 (IEEE Address), press the PRGM button and then the "3" and "1" buttons.

A program can be exited at any time, without changing previous program parameters, by pressing the PRGM button.

Data Entry

Program data is applied from the front panel using the data buttons. The data buttons consists of the buttons labelled with the \pm polarity sign and numbers 0 through 9. Data entry is accomplished by pressing the appropriate number button at each cursor location. Cursor location is indicated by the bright, flashing display digit. The cursor moves one digit to the right every time a number is entered.

Program 0 (Menu)

This program displays the software revision level of the Model 196 and lists the available front panel programs. After the program is selected, use the manual range buttons (\blacktriangledown and \blacktriangle) to scroll through the program listing. To exit from the menu, press the PRGM button.

Program 2 (Resolution)

This program is used for the selection of the number of digits of display resolution for the presently selected function. Available resolution is dependent on function and range. After the program is selected, display the desired resolution using the \blacktriangledown and \blacktriangle buttons, and then press the ENTER button.

Program 4 (MX+B)

Program 4 allows the user to enable or disable the MX+B feature. The MX+B feature allows the user to automatically multiply normal display readings (X) by a constant (M) and

add a constant (B). The result (Y) will be displayed in accordance with the formula, $Y=MX+B$. After the program is selected, any manual range button will toggle the display to the alternate status. The ENTER button will enter the displayed status.

Program 5 (HI/LO/Pass)

When this program is selected, the Model 196 will indicate whether or not a specific reading falls within a prescribed range. The instrument will display the HI or LO message for out-of-limit readings and the PASS message for in-limit readings. The HI and LO limits can be set to any on-range value with Program 35 (HI/LO Limits). To disable the program, press the presently selected function button.

Program 6 (Auto/Cal Multiplexer)

Program 6 allows the user to disable and enable the multiplex circuitry. With the multiplexer disabled, measurement speed is increased and high impedance DCV measurements can be made. After the program is selected, any range button will toggle the display to the alternate status. The ENTER button enters the displayed status.

Program 30 (Save)

Program 30 saves the present set up parameter. These conditions will replace the previously saved conditions on power up. After the program is selected, pressing the ENTER button will cause the present set up to be saved. Pressing any other button will cause the instrument to exit Program 30 without changing the previously saved set up.

Program 31 (IEEE Address)

Program 31 allows the user to check and/or modify the IEEE-488 primary address. After Program 31 is selected, the current IEEE address value will be displayed. To retain the current IEEE value, press the ENTER button. To change the primary address, enter a new value (0 to 31) and press the ENTER button.

Program 32 (Line Frequency)

Program 32 allows the user to check the line frequency setting of the instrument and to select the alternate frequency setting. The instrument can be set to either 50 or 60Hz. After the program is selected, any range button will toggle the display to the alternate setting. The ENTER button will enter the displayed setting.

Program 33 (Diagnostic)

Program 33 is a diagnostic program designed to switch on various switching FET's, relays and logic levels to allow signal tracing through the instrument. Also, tests on the display and memory are performed. Refer to paragraph 6.7.3 in the maintenance section of the manual to use this program to troubleshoot the instrument.

Program 34 (MX+B Parameters)

Program 34 allows the user to check and change the M and B values for the MX+B feature (Program 4). Valid M values are in the range of -9.999999 to $+9.999999$. The B value range is from $\pm 0.0001 \times 10^{-3}$ to ± 9999.999 (including zero). After Program 34 is selected, the current M value will be displayed. To retain the displayed value, press the ENTER button. To change the M value, enter a value and press the ENTER button. The current B value will then be displayed.

To retain the displayed B value, press the ENTER button. To change the B value, enter a value and press the ENTER button. Note that the value B is scaled according to the range in use.

Program 35 (HI/LO Limits)

This program is used to set the high and low limits for Program 35 (HI/LO/Pass). The limit values are scaled according to the range in use. When the program is selected, the currently programmed low limit is displayed. Modify the value, if desired, and press the ENTER button. The high limit will then be displayed. Modify the high limit, if desired, and press the ENTER button.

Program 36 (Calibration)

The user can easily perform front panel digital calibration by applying accurate calibration signals and using Program 36. Calibration signals can be prompted default values or values entered from the front panel. Refer to the Model 196 Instruction Manual, Section 6 for complete information.

Program 37 (Reset)

Program 37 resets all instrument set up parameters back to the factory default conditions. After the program is selected, pressing the ENTER button will reset the instrument to factory default conditions. Pressing any other button will cause the instrument to exit Program 37 without resetting the parameters. After running this program, Program 30 must be run to have factory default conditions on power up.

Program Ω

Ohms compensation is used to compensate for external voltage potentials across the unknown resistor when making 2 or 4-terminal resistance measurements up to 300k Ω . After this program is selected, any range button will toggle the display to the alternate status (on/off). The ENTER button enters the displayed status. With ohms compensation enabled, the Ω indicator light will blink when the ohms function is selected.

Program ZERO

Program ZERO allows the user to check and modify the zero value. After Program ZERO is selected the current zero value will be displayed. If desired, change the displayed zero value and press the ENTER button. The instrument will return to the previous operating state with the zero modifier enabled. The subsequent displayed reading will reflect the entered zero value.

Program FILTER

Program FILTER allows the user to check and modify the number of readings averaged by the filter. After the program is selected the current filter value will be displayed. Alter the filter value, if desired, and press the ENTER button. The instrument will return to the previous operating state with the filter enabled using the programmed filter value.

Program dB

This program allows the user to check and/or change the dB reference level. When this program is selected, the currently programmed reference level will be displayed. Alter the reference level, if desired, and press the ENTER button. The reference range for ACV is up to 9.99999V and the range for current is up to 9.99999mA.

LOCAL

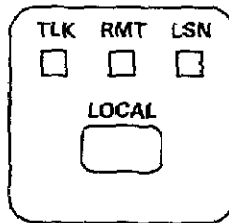

The LOCAL button allows the user to return control to the front panel when the instrument is being controlled over the IEEE-488 bus (RMT indicator light on). This button will have no effect if local lockout (LLO) was asserted over the bus.

FRONT PANEL TRIGGERING

For front panel triggering, the instrument must be placed in the appropriate trigger mode from over the IEEE-488 bus.

One-shot Triggering:

1. Select function and range.
2. Place the instrument in the one-shot trigger mode by sending the T7 command over the bus.
3. Press the LOCAL button to return control to the front panel.
4. Each press of the ENTER button will trigger a reading.

Triggering Readings Into Data Store:

1. Select function and range.
2. Place the instrument in the appropriate trigger mode:
 - A. Send T7 (one-shot) over the bus if each press of the ENTER button is to store one reading in the buffer.
 - B. Send T6 (continuous) over the bus if the ENTER button is to start storage of a series of readings into the buffer.
3. Configure the data store by sending the appropriate Qn (interval) and I (size) commands over the bus.
4. Press the LOCAL button to return control to the front panel.
5. Press the ENTER button to either store one reading or start storage of a series of readings.

EXTERNAL TRIGGERING

The Model 196 has two external BNC connectors on the rear panel associated with instrument triggering. The EXTERNAL TRIGGER INPUT allows the instrument to be triggered by other devices, while VOLTMETER COMPLETE OUTPUT allows the instrument to trigger other devices.

External Trigger Input

1. Set the Model 196 to the one-shot external trigger mode (T7) or the continuous external trigger mode (T6).
2. Input an appropriate trigger pulse source (see FIG 1) to the EXTERNAL TRIGGER INPUT.
3. The instrument will process a single reading each time a pulse is applied (one-shot), or start a continuous series of readings.

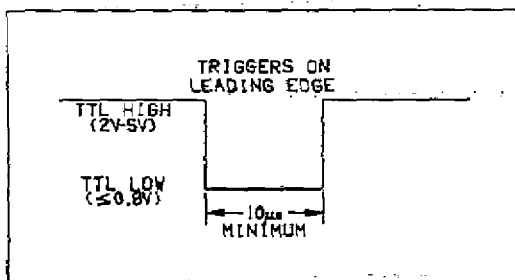

FIG 1. External Trigger Pulse Specifications

Voltmeter Complete Output

The voltmeter complete pulse (see FIG 2) signifies completion of the measurement cycle. The voltmeter complete line can be used to trigger another instrument or to inform an instrument that the measurement has been completed.

1. Connect the VOLTMETER COMPLETE OUTPUT of the Model 196 to the external trigger input of another instrument.
2. In a continuous trigger mode, the instrument will output pulses at the conversion rate; each pulse will occur after the Model 196 has completed a conversion.
3. In a one-shot trigger mode, the Model 196 will output a pulse once each time it is triggered.

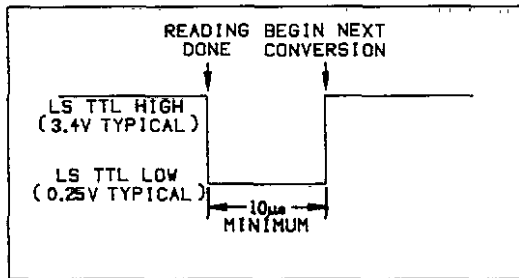

FIG 2. Voltmeter Complete Pulse Specification

IEEE-488 PROGRAMMING

This section briefly describes Model 196 operation over IEEE-488 bus. All device-dependent commands are listed. More detailed information and programming examples are listed in the Model 196 Instruction Manual.

Execute

X = Execute other device-dependent commands.

Function

F0 = DC volts
F1 = AC volts
F2 = Ohms
F3 = DC current
F4 = AC current
F5 = ACV dB
F6 = ACA dB
F7 = Offset compensated ohms

Range

DCV	ACV	DCA	ACA
R0 = Auto	Auto	Auto	Auto
R1 = 300mV	300mV	300 μ A	300 μ A
R2 = 3 V	3 V	3mA	3mA
R3 = 30 V	30mV	30mA	30mA
R4 = 300 V	300 V	300mA	300mA
R5 = 300 V	300 V	3 A	3 A
R6 = 300 V	300 V	3 A	3 A
R7 = 300 V	300 V	3 A	3 A

Range (Cont.)			
Ohms	ACV dB	ACA dB	Offset Compensated Ohms
R0 = Auto	Auto	Auto	Auto
R1 = 300 Ω	Auto	Auto	300 Ω
R2 = 3 kΩ	Auto	Auto	3 kΩ
R3 = 30 kΩ	Auto	Auto	30 kΩ
R4 = 300 kΩ	Auto	Auto	30 kΩ
R5 = 3MΩ	Auto	Auto	30 kΩ
R6 = 30MΩ	Auto	Auto	30 kΩ
R7 = 300MΩ	Auto	Auto	30 kΩ

Zero
Z0 = Zero disabled
Z1 = Zero enabled
Z2 = Zero enabled using a zero value (V)

Filter
P0 = Filter disabled
Pn = Filter on with a value of n (n = 1 to 99)

Rate			
	Resolution		
DCV	ACV	DCA	ACA
S0 = 3½d	3½d	3½d	3½d
S1 = 4½d	4½d	4½d	4½d
S2 = 5½d	5½d	5½d	5½d
S3 = 6½d	5½d	5½d	5½d

Rate (Cont.)				
Resolution				
OHMS	ACV dB	ACA dB	Offset Compensated Ohms	
S0 = 3½d(R1-R4) 5½d(R5-R7)	5½d	5½d	5½d	
S1 = 4½d(R1-R4) 5½d(R5-R7)	5½d	5½d	5½d	
S2 = 5½d	5½d	5½d	5½d	
S3 = 6½d(R1-R6) 5½d(R7)	5½d	5½d	6½d	

Integration period: 3½d=318µsec, 4½d=2.59msec,
5½d and 6½d=Line cycle

Trigger Mode
T0 = Continuous on Talk
T1 = One-shot on Talk
T2 = Continuous on GET
T3 = One-shot on GET
T4 = Continuous on X
T5 = One-shot on X
T6 = Continuous on External Trigger
T7 = One-shot on External Trigger

Reading Mode
B0 = Readings from A/D converter
B1 = Readings from data store

Data Store Size
I0 = Continuous data store mode
In = Data store of n (n=1 to 500)

Data Store Interval

Q0 = One-shot into buffer
Qn = n=interval in milliseconds (1msec to 99999msec)

Value

$V \pm nn.nnnn$ or = Calibration value, zero value
 $V \pm n.nnnnnnE+n$

Calibration

C0 = Calibrates first point using value (V)
C1 = Calibrate second point using value (V)

Default Conditions

L0 = Restore factory default conditions.
L1 = Store present machine status as default conditions

Data Format

G0 = Reading with prefixes.
G1 = Reading without prefixes.
G2 = Buffer readings with prefixes and buffer locations.
G3 = Buffer readings without prefixes and with buffer locations.
G4 = Buffer readings with prefixes and without buffer locations.
G5 = Buffer readings without prefixes and without buffer locations.

SRQ

M0 = Disable
M1 = Reading overflow
M2 = Data store full
M4 = Data store half full
M8 = Reading done
M16 = Ready
M32 = Error

EOI and Bus Hold-off

K0 = Enable EOI and bus hold-off on X
K1 = Disable EOI, enable bus hold-off on X
K2 = Enable EOI, disable bus hold-off on X
K3 = Disable both EOI and bus hold-off on X

Terminator

Y0 = CR LF
Y1 = LF CR
Y2 = CR
Y3 = LF

Status

U0 = Send machine status word
U1 = Send error conditions
U2 = Send Translator word
U3 = Send buffer size
U4 = Send average reading in buffer
U5 = Send lowest reading in buffer
U6 = Send highest reading in buffer
U7 = Send current value
U8 = Send input switch status (front/rear)

Multiplex

A0 = Auto/Cal Multiplexer disabled
A1 = Auto/Cal Multiplexer enabled

Delay

Wn = n=delay period in milliseconds, (0msec to 60000msec)

Self-test

J0 = Test, ROM, RAM, E²PROM

Hit Button

Hn = Hit front panel button number n

Display

Da = Display up to 10 character message
a = character
D = Cancel display mode

Internal Filter

N0 = Internal filter off
N1 = Internal filter on

FACTORY DEFAULT CONDITIONS

Mode	Command	Status
Multiplex	A1	Enabled
Reading	B0	A/D converter
Function	F0	DC volts
Data Format	G0	Send prefix with reading
Self-test	J0	Clear
EOI	K0	Enable EOI and bus hold-off on X
SRQ	M0	Disabled
Internal Filter	N1	Enabled
Digital Filter	P0	Disabled
Data Store Interval	Q0	One-shot into buffer
Data Store Size	I1	One reading
Range	R4	Depends on function
Rate	S3	Depends on function and range
Trigger	T6	Continuous on external trigger
Delay	W0	No delay
Terminator	Y0	CR LF
Zero	Z0	Disabled

BUS ERROR MESSAGES

Message	Description
NO REMOTE	Instrument programmed with REN false.
IDDC	Illegal Device-dependent Command
IDDCO	Illegal Device-dependent Command Option
TRIG ERROR	Instrument triggered while it is still processing a previous trigger.
SHORT TIME	Instrument cannot store readings at programmed interval. Readings will be stored as fast as the instrument can run.
BIG STRING	Programmed display message exceeds 10 characters.
CAL LOCKED	Calibration command sent with calibration switch in the disable position.
CONFLICT	Data Storage—Instrument cannot store readings at a high speed interval (1 to 14msec) while in an invalid state. Storage will not occur. Calibration—Calibration command is ignored when instrument is in an invalid state (i.e., dB function).

Note: Errors associated with Translator are located in the Translator Software section.

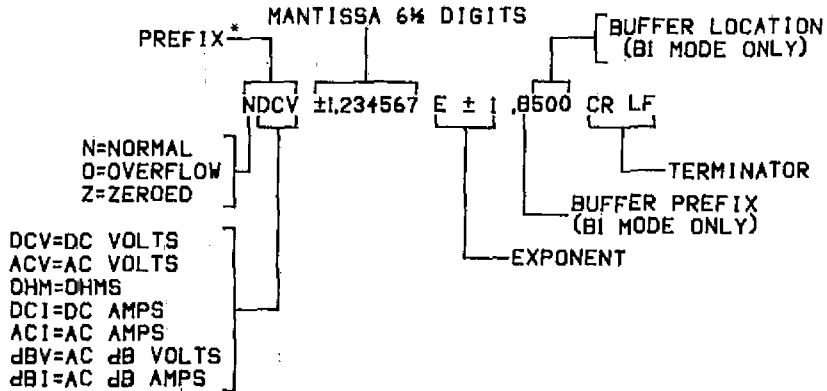

*NONE = DATA STORE EMPTY

GENERAL DATA FORMAT

SERIAL POLL BYTE
(Status Byte)

BIT POSITION	B7	B6	B5	B4	B3	B2	B1	B0
VALUE	0	1/0	1/0	1/0	1/0	1/0	1/0	1/0
DECIMAL WEIGHTING	128	64	32	16	8	4	2	1

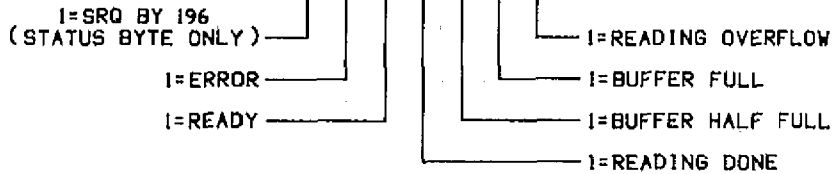

FACTORY DEFAULT																	
1	0	0	0	0	0	00	1	00	000000	4	3	6	00000	0	0	0/1	
																CAL	
196	A	B	F	G	J	K	MM	N	PP	QQQQQQ	R	S	T	WWWWW	Y	Z	SW

STATUS WORDS
MACHINE STATUS (U0)

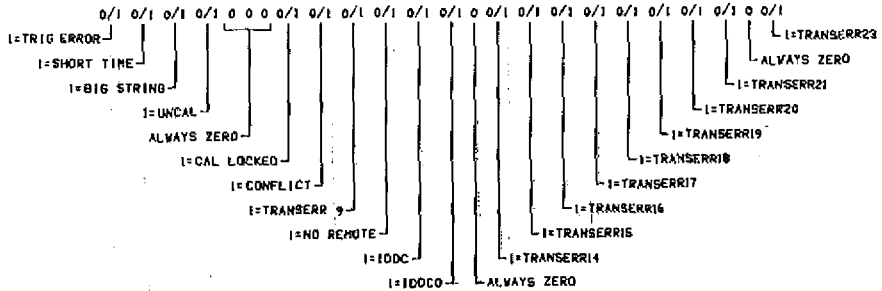

ERROR STATUS (U1)

TRANSLATOR SOFTWARE

RESERVED WORDS AND CHARACTERS

Word/Character	Description
ALIAS	Used at the beginning of a command string to define Translator words.
;	Used to terminate the Translator string (one space must precede it).
\$	Used to define wild card Translator words. Values sent with a wild card Translator word select options of the equivalent DDC.
NEW	Tells the Model 196 to recognize Translator words.
OLD	Tells the Model 196 to only recognize the Keithley device-dependent commands.
SAVE	Saves Translator words as power up default.
LIST	Used to list the Translator words.
FORGET	Used to purge Translator words from memory.

TRANSLATOR FORMAT

The basic format for defining a Translator word is shown in the following example command string, which defines the word SETUP 1 as a substitute for F1ROX.

```
"ALIAS SETUP1 F1ROX ;"
```

WILD CARD (\$) TRANSLATOR WORDS

By using the reserved character \$, the same basic Translator word can be used to select all options of a command. With this feature, a DDC option number is sent with the Translator word. The following example shows the format for defining a wild card Translator word:

```
"ALIAS FUNCTION F$X ;"
```

In the example, the wild card Translator word FUNCTION replaces the F command. Instrument functions are selected by sending the FUNCTION command with the appropriate option number over the bus.

COMBINING TRANSLATOR WORDS

The format for combining Translator words to form a new Translator word is shown in the following example, which combines the words SETUP1 and SETUP2 to form the Translator word SETUP3.

```
"ALIAS SETUP3 NEW SETUP1 NEW SETUP2 ;"
```

COMBINING TRANSLATOR WORDS WITH KEITHLEY IEEE-488 COMMANDS

The format for combining a Translator word with Keithley IEEE commands is shown in the following example, which combines the Translator word SETUP1 with the Keithley command string PIZ1X to form the Translator word SETUP4.

```
"ALIAS SETUP4 NEW SETUP1 PIZ1X ;"
```

EXECUTING TRANSLATOR WORDS AND KEITHLEY COMMANDS

Translator words can only be executed with the instrument in the NEW mode. Sending the reserved word NEW over the bus places the instrument in the NEW mode. The formats for placing the instrument in the NEW mode and for executing the Translator word SETUP1, is shown as follows:

```
"NEW"  
"SETUP1"
```

The reserved word ALIAS automatically puts the instrument in the NEW mode.

Sending wild card Translator words over the bus is as follows:

```
"NEW"  
"FUNCTION 1"
```

With FUNCTION being the wild card Translator word for the F command, the second statement will place the instrument in the ACV function (F1). Notice that a space must be included between the wild card Translator word the option number.

Translator words and Keithley IEEE commands can be executed in the same command string. The following example executes the commands of SETUP1 and P1Z1X.

```
"SETUP1 P1Z1X"
```

When executing a Translator word that was formed from the combination of two or more wild card Translator words, an option number sent with the word will only apply to the first wild card word in the combined string. For example, assume the Translator word TEST was formed from the combination of the wild card Translator words FUNCTION and RANGE as shown:

“ALIAS TEST NEW FUNCTION NEW RANGE ;”

Sending TEST 1 over the bus will place the instrument in ACV (F1). RANGE will default to 0 (autorange).

Translator Error Messages

Display Message	Explanation	Example Error String
TRANSERR 9 TRANSERR14	No more memory left for Translator words. Use of more than one ALIAS in a definition.	— "ALIAS TEST1 F1X ALIAS TEST2 R1X ;"
TRANSERR15	Translator word exceeds 31 characters.	"ALIAS ITHINKTHISISSTHIRTYTWO CHARACTERS! F1X ;"
TRANSERR16	Use of an X in a Translator word.	"ALIAS XRAY F1X ;"
TRANSERR17	Trying to define a Translator word that already exists. The second string in the example is the error string.	"ALIAS SETUP F1X ;" " "ALIAS SETUP F1X ;"
TRANSERR18	Use of a \$ in a Translator words.	"ALIAS \$200 F1X ;"
TRANSERR19	Sending the ; character.	" ;"
TRANSERR20	Use of LIST in a Translator definition.	"ALIAS DOG F1X LIST ;"
TRANSERR21	Use of FORGET in a Translator definition.	"ALIAS DOG F1X FORGET ;"
TRANSERR23	Use of SAVE in a Translator definition.	"ALIAS DOG F1X SAVE ;"

PROGRAMS

The following programs are designed to be a simple aid to the user. They are not intended to suit specific needs. Detailed programming information can be found in the manual.

The first program demonstrates how to store and read the contents of the buffer (data store) using the HP-85 computer. One hundred readings stored in the buffer will be displayed.

The rest of the programs display one reading at the output of the controller. Each program provides an ASCII string variable output of the form:

NDCV ± 0.000000E + 0 CR LF

The note at the end of some programs indicates modifications to provide a numeric variable in exponential form:

±0.000000E + 0

DATA STORE OPERATION USING HP-85

The following program will enable data store (buffer) operation and obtain and display 100 readings on the computer CRT.

DIRECTIONS

1. Using front panel Program 31, set the primary address on the Model 196 to 7.
2. Connect the Model 196 to the HP82937A IEEE interface.
3. Enter the following program using the END LINE key after each line is typed.
4. Press the HP-85 run key. The program will enable the buffer, turn on the buffer output, and request and display 100 readings.

<u>PROGRAM</u>	<u>COMMENTS</u>
10 DIM A\$(25)	
20 REMOTE 707	Send remote enable.
30 OUTPUT 707; " T20200I100X"	Set trigger mode, and storage parameters.
40 TRIGGER 707	Start storage process.
50 OUTPUT 707; " B10X"	Set read mode to data store.
60 FOR I=1 TO 100	Set counter for 100 loops.
70 ENTER 707; A\$	Get a reading.
80 DISP A\$	Display reading.
90 NEXT I	Loop back for next reading.
100 END	

IBM PC or XT

(Keithley Model 8573A Interface)

The following program sends a command string to the Model 196 from an IBM PC or XT computer and displays the instrument reading string on the CRT. The computer must be equipped with the Keithley Model 8573A IEEE-488 Interface and the DOS 2.00 operating system. Model 8573A software must be installed and configured as described in the instruction manual.

DIRECTIONS

1. Using the front panel program feature, set the primary address of the Model 196 to 7.
2. With the power off, connect the Model 196 to the IEEE-488 interface installed in the IBM computer.
3. Type in BASICA on the computer keyboard to get into the IBM interpretive BASIC language.
4. Place the interface software disk in the default drive, type LOAD"DECL", and press the return key.
5. Add the lines below to line 1-6 which are now in memory. Modify the address in lines 1 and 2, as described in the Model 8573A Instruction Manual.
6. Run the program and type in the desired command string. For example, to place the instrument in the ACV function and autorange, type in F1ROX and press the return key.
7. The instrument reading string will then appear on the display. For example, the display might show NDCV+0.000000E+0.
8. To exit the program, type in EXIT at the command prompt and press the return key.

PROGRAM	COMMENTS
10 CLS	Clear screen.
20 NA\$=' GPIB0' : CALL IBFIND (NA\$, BRD0%)	Find board descriptor.
30 NA\$=' DEV1' : CALL IBFIND (NA\$, M196%)	Find instrument descriptor.
40 U%=7 : CALL IBPAD (M196%, U%)	Set primary address to 7.
50 U%=&H102 : CALL IBPKE (BRD0%, U%)	Set timeouts.
60 U%=1 : CALL IBGRE (BRD0%, U%)	Set REN true.
70 INPUT ' COMMAND STRING' : CMD\$	Prompt for command.
80 IF CMD\$=' EXIT' THEN 150	See if program is to be halted.
90 IF CMD\$=' ' THEN 70	Check for null input.
100 CALL IBWRT (M196%, CMD\$)	Address 196 to listen, send string.
110 RD\$=SPACE*(100)	Define reading input buffer.
120 CALL IBRD (M196%, RD\$)	Address 196 to talk, get reading.
130 PRINT RD\$	Display the string.
140 GOTO 70	Repeat.
150 U%=0 : CALL IBONL (M196%, U%)	Close the instrument file.
160 CALL IBONL (BRD0%, U%)	Close the board file.
170 END	

NOTE: For conversion to numeric variable, make the following changes:

```
130 RD=VAL (MID$(RD$,
5, 14))
135 PRINT RD
```

APPLE II

(APPLE II IEEE-488 Interface)

The following program sends a command string to the Model 196 from an Apple II computer and displays the instrument reading string on the computer CRT.

The computer must be equipped with the Apple II IEEE-488 interface installed in slot 3.

DIRECTIONS

1. Using the front panel program feature, set the primary address of the Model 196 to 7.
2. With the power off, connect the Model 196 to the IEEE-488 interface installed in the Apple II computer.
3. Enter the lines in the program below, using the RETURN key after each line.
4. Run the program and type in the desired command string at the command prompt. For example, to place the instrument in ACV and autorange, type in F1R0X and press the return key.
5. The instrument reading string will then appear on the CRT. A typical display is: NDCV+0.000000E+0.

PROGRAM	COMMENTS
10 Z\$=CHR\$(26)	Terminator
20 INPUT "COMMAND STRING?":B\$	Prompt for and enter command string.
30 PR#3	Set output to IEEE-488 bus.
40 IN#3	Define input from IEEE-488 bus.
50 PRINT "RA"	Enable remote.
60 PRINT "WT";Z\$;B\$	Address 196 to listen, send string.
70 PRINT "LF1"	Line feed on.
80 PRINT "RDG";Z\$; :INPUT " ";A\$	Address 196 to talk, input data.
90 PRINT "UT"	Untalk the 196.
100 PR#0	Define output to CRT.
110 IN#0	Define input from keyboard.
120 PRINT A\$	Display reading string.
130 GOTO 20	Repeat.

NOTES:

1. If conversion to numeric variable is required, make the following changes:

```
120 A=VAL(MID$(A$,5,
16))
125 PRINT A
```

2. The Apple II terminates on commas in the data string. To avoid problems, program the Model 196 for the BOGO or BOG1 data format to eliminate commas.

HP-85

The following program sends a command string to the Model 196 from an HP-85 computer and displays the instrument reading on the computer CRT. The computer must be equipped with the HP82937 GPIB interface and an I/O ROM.

DIRECTIONS

1. Using the front panel program feature, set the primary address of the Model 196 to 7.
2. With the power off, connect the Model 196 to the HP82937A GPIB interface installed in the HP-85 computer.
3. Enter the lines in the program below, using the END LINE key after each line.
4. Press the HP-85 RUN key and type in the desired command string at the command prompt. For example, to place the instrument in ACV and autorange, type in F1ROX and press the END LINE key.
5. The instrument reading string will then appear on the CRT. A typical display is: NDCV+0.000000E+0.

PROGRAM	COMMENTS
10 DIM A\$(25), B\$(25)	Dimension strings.
20 REMOTE 707	Place 196 in remote.
30 DISP "COMMAND STRING";	Prompt for command.
40 INPUT A\$	Input command string.
50 OUTPUT 707; A\$	Address 196 to listen, send string.
60 ENTER 707; B\$	Address 196 to talk, in- put reading.
70 DISP B\$	Display reading string.
80 GOTO 30	Repeat
90 END	

NOTE: For conversion to numeric variable, change line 70 as follows:

```
70 DISP VAL(B$(5))
```

HP-9816

The following program sends a command string to the Model 196 from a HP-9816 computer and displays the instrument reading string on the computer CRT. The computer must be equipped with the HP82937 GPIB interface and BASIC 2.0.

DIRECTIONS

1. Using the front panel program feature, set the primary address of the Model 196 to 7.
2. With the power off, connect the Model 196 to the HP82937A GPIB interface installed in the 9816 computer.
3. Type EDIT and press the EXEC key.
4. Enter the lines in the program below, using the ENTER key after each line.
5. Press the 9816 RUN key and type in the desired command string at the command prompt. For example, to place the instrument in ACV and autorange, type in F1ROX and press the ENTER key.
6. The instrument reading string will then appear on the CRT. A typical display is NDCV+0.000000E+0.

PROGRAM	COMMENTS
10 REMOTE 707	Place 196 in remote.
15 DIM A\$(25); B\$(25)	
20 INPUT "COMMAND STRING", A\$	Prompt for and input command.
30 OUTPUT 707; A\$	Address 196 to listen, send string.
40 ENTER 707; B\$	Address 196 to talk, input reading.
50 PRINT B\$	Display reading string.
60 GOTO 20	Repeat.
70 END	

NOTE: For conversion to a numeric variable, change the program as follows:

```
40 ENTER 707; B
50 PRINT B
```

HP-9825A

Use the following program to send a command string to the Model 196 from a HP-9825A and display the instrument reading string on the computer printer. The computer must be equipped with the HP98034A GPIB interface and a 9872A extended I/O ROM.

DIRECTIONS

1. From the front panel, set the primary address of the Model 196 to 7.
2. With the power off, connect the Model 196 to the 98034A HP-IB interface installed in the 9825A.
3. Enter the lines in the program below, using the STORE key after each line. Line numbers are automatically assigned by the 9825A.
4. Press the 9825A RUN key and type in the desired command string at the command prompt. For example, to place the instrument in ACV and autorange, type in F1R0X and press the CONT key.
5. The instrument reading string will then appear on the computer print out. A typical display is:
NDCV+0.000000E+0.

PROGRAM	COMMENTS
0 DIM A#[25],B#[25]	Dimension data strings.
1 DEV "196",70?	Define 196 at address 7.
2 REM "196"	Place 196 in remote.
3 ENT "COMMAND STRING" ,B#	Prompt for command string.
4 WRT "196",B#	Address 196 to listen, send string.
5 RED "196",A#	Address 196 to talk, input data.
6 PRT A#	Print data string on printer.
7 GTO 3	Repeat.

NOTE: For conversion to numeric variable, modify the program as follows:

```
6 PRT UAL (A#[5])
```

DEC LSI 11

The following program sends a command string to the Model 196 from a DEC LSI 11 minicomputer and displays the instrument reading string on the DEC CRT terminal. The LSI 11 must be configured with 16K words or RAM and an IBV 11 IEEE-488 interface. The software must be configured with the IB software as well as FORTRAN and the RT 11 operating system.

DIRECTIONS

1. Using the front panel program feature, set the primary address of the Model 196 to 7.
2. With the power off, connect the Model 196 to the IBV 11 IEEE-488 interface cable.
3. Enter the program below, using the editor under RT 11 and the name IEEE.FOR.
4. Compile using the FORTRAN compiler as follows:
FORTRAN IEEE.
5. Link with the system and IB libraries as follows: LINK IEEE,IBLIB.
6. Type RUN IEEE and press the RETURN key.
7. The display will read "ENTER ADDRESS".
8. Type in 7 and press the RETURN key.
9. The display will read "TEST SETUP".
10. Type in the desired command string and press the RETURN key. For example, to program the instrument for ACV and autorange, type in F1ROX and press RETURN.
11. The instrument data string will appear on the computer display. A typical display is: NDCV+0.000000+E.

PROGRAM**COMMENTS**

PROGRAM IEEE11	
INTEGER*2 PRIADR	
LOGICAL*1 MSG(80), INPUT(80)	
DO 2 I=1, 10	
CALL IBSTER(I,0)	Turn off IB errors.
2 CONTINUE	
CALL IBSTER(15,5)	Allow 5 error 15's.
CALL IBTIMO(120)	Allow 1 second bus timeout.
CALL IBTERM(10)	Set line feed as terminator.
CALL IBREN	Turn on remote.
4 TYPE 5	
5 FORMAT (1X, 'ENTER ADDRESS:', #)	Input primary address.
ACCEPT 10, PRIADR	
10 FORMAT(I2)	
12 TYPE 15	
15 FORMAT (1X, 'TEST SETUP?', #)	Prompt for com- mand string.
CALL GETSTR (5, MSG, 72)	Program instrument.
CALL IBSEOI (MSG, -1, PRIADR)	Address 196 to listen, send string.
18 I=IBRECU (INPUT, 80, PRIADR)	Get data from instrument.
INPUT (I+1)=0	
CALL PUTSTR (7, INPUT, '0')	Untalk the 196.
CALL IBUNT	Repeat.
GOTO12	
END	

PET/CBM 2001

The following program sends command strings to the Model 196 from a PET/CBM 2001 computer and displays the instrument reading string on the computer CRT. As the PET/CBM computer has a standard IEEE-488 interface, no additional equipment is necessary.

DIRECTIONS

1. Using the front panel program feature, set the primary address of the Model 196 to 7.
2. With the power off, connect the Model 196 to the PET/CBM IEEE-488 interface.
3. Enter the lines of the program below, using the RETURN key after each line is typed.
4. Type RUN and press the RETURN key. Type in the desired command string at the command prompt. For example, to place the instrument in ACV and autorange, type in F1ROX and press the RETURN key.
5. The instrument reading string will then appear on the CRT. A typical display is: NDCV+0.000000+E0.

PROGRAM	COMMENTS
10 OPEN 1,7	Open file 1, primary address 7.
20 INPUT 'COMMAND STRING',B\$	Prompt for input command string.
30 PRINT #1,B\$	Address 196 to listen, send string.
40 INPUT#1,A\$	Address 196 to talk, input data.
50 IF ST=2 THEN 40	If bus timeout, input again.
60 PRINT A\$	Display reading string.
70 GOTO 20	Repeat.

NOTES:

1. If conversion to numeric variable is required, modify the program as follows:

```

70 A=VAL(MID$(A$,5,15))
80 PRINT "A=";A
90 GOTO 20

```

2. The PET terminates on commas in the data string. To avoid problems, program the Model 196 for the BOG0 or BOG1 data format to eliminate commas.



Artisan Technology Group is your source for quality new and certified-used/pre-owned equipment

- FAST SHIPPING AND DELIVERY
- TENS OF THOUSANDS OF IN-STOCK ITEMS
- EQUIPMENT DEMOS
- HUNDREDS OF MANUFACTURERS SUPPORTED
- LEASING/MONTHLY RENTALS
- ITAR CERTIFIED SECURE ASSET SOLUTIONS

SERVICE CENTER REPAIRS

Experienced engineers and technicians on staff at our full-service, in-house repair center

*InstraView*SM REMOTE INSPECTION

Remotely inspect equipment before purchasing with our interactive website at www.instraview.com ↗

WE BUY USED EQUIPMENT

Sell your excess, underutilized, and idle used equipment. We also offer credit for buy-backs and trade-ins. www.artisanng.com/WeBuyEquipment ↗

LOOKING FOR MORE INFORMATION?

Visit us on the web at www.artisanng.com ↗ for more information on price quotations, drivers, technical specifications, manuals, and documentation

Contact us: (888) 88-SOURCE | sales@artisanng.com | www.artisanng.com