



Artisan Technology Group is your source for quality new and certified-used/pre-owned equipment

- FAST SHIPPING AND DELIVERY
- TENS OF THOUSANDS OF IN-STOCK ITEMS
- EQUIPMENT DEMOS
- HUNDREDS OF MANUFACTURERS SUPPORTED
- LEASING/MONTHLY RENTALS
- ITAR CERTIFIED SECURE ASSET SOLUTIONS

SERVICE CENTER REPAIRS

Experienced engineers and technicians on staff at our full-service, in-house repair center

*InstraView*SM REMOTE INSPECTION

Remotely inspect equipment before purchasing with our interactive website at www.instraview.com ↗

WE BUY USED EQUIPMENT

Sell your excess, underutilized, and idle used equipment. We also offer credit for buy-backs and trade-ins. www.artisanng.com/WeBuyEquipment ↗

LOOKING FOR MORE INFORMATION?

Visit us on the web at www.artisanng.com ↗ for more information on price quotations, drivers, technical specifications, manuals, and documentation

Contact us: (888) 88-SOURCE | sales@artisanng.com | www.artisanng.com

MMI-200 SERIES

Operating and Installation Instructions

for use with MMI-200, 210, 220 and 240

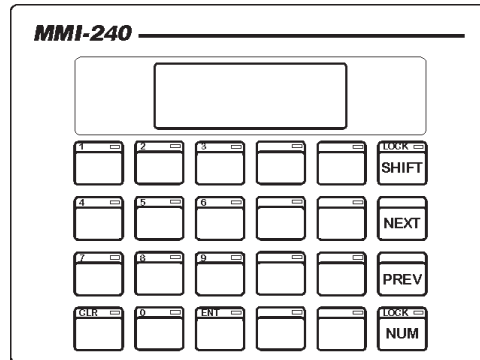
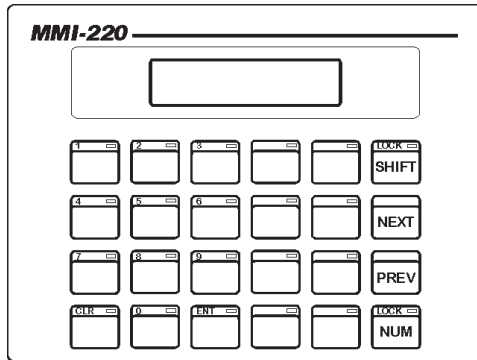
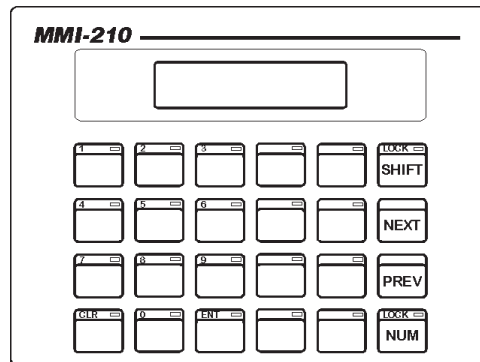
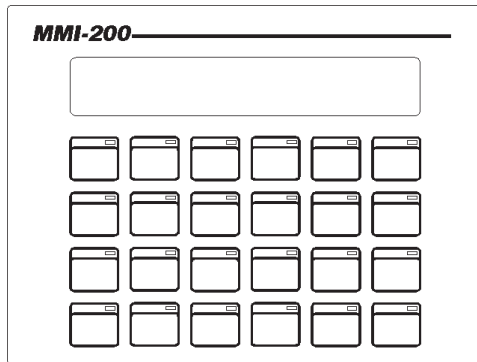

Kessler Ellis Products
10 Industrial Way East
Eatontown, NJ 07724
Phone: 732-935-1320
FAX: 732-935-9344

\$10.00
99582REV22JUN01

Warranty

We hope you will be pleased with our product. If you have any questions concerning our warranty, repair, modification or returned goods process, please contact your local distributor.

WARRANTY

This product is warranted against defects in materials and workmanship for a period of 12 months from the date of shipment to Buyer.

The Warranty is limited to repair or replacement of the defective unit at the option of the manufacturer. This warranty is void if the product has been altered, misused, dismantled, or otherwise abused.

ALL OTHER WARRANTIES, EXPRESSED OR IMPLIED, ARE EXCLUDED, INCLUDING BUT NOT LIMITED TO THE IMPLIED WARRANTIES OF MERCHANTABILITY AND FITNESS FOR A PARTICULAR PURPOSE.

PROPRIETARY NOTICE

The information contained in this publication is derived in part from proprietary and patent data. This information has been prepared for the expressed purpose of assisting operating and maintenance personnel in the efficient use of the instrument described herein. Publication of this information does not convey any rights to use or reproduce or to use it for any purpose other than in connection with the installation, operation and maintenance of the equipment described herein.

**Copyright 1997 by
Kessler Ellis Products**

Contents

Section	Page
1.0 Getting Started	4
1.1 What is the MMI-2XX Series?	4
1.1.1 The MMI Series and Its Environment	5
2.0 Installation Instructions	6
2.1 Mounting Instructions	6
2.1.1 Location Considerations.	6
2.1.2 Making a NEMA4 Mounting.	6
2.1.3 Environmental Considerations	7
2.2 Power Connections	8
2.2.1 Power Requirements	8
2.2.2 Grounding Requirements	10
2.2.3 CE Requirements	10
2.2.4 Safety Guidelines	11
2.3 Communications Connections	12
2.3.1 Connection to an External Device	12
2.3.2 Connection to a Personal Computer	13
2.4 CE Requirements	14
2.4.1 EU directives	14
2.4.2 General Installation Guide Lines for EU Installations.	15
2.4.3 General Safety Guide Lines for EU Installations	15

Section	Page
3.0 MMI Operations	16
3.1 The Message Queue	16
3.1.1 Queue Activation	16
3.1.2 Queue Action	16
3.1.3 The Interrupt Message	16
3.2 Using the Function keys	17
3.3 Entering Numerical Values	18
3.4 Using the PREV and NEXT keys	20
3.5 Activating the Beeper	20
3.6 Activating the Open Collector Output	21
3.7 Using the Keypad Download	21
3.8 MMI Response	22
3.8.1 Response Time to Message Calls, LED and O.C. Output Activation	22
3.8.2 Response Time to Function Key Presses	22
3.8.3 Response Time to Serial Port Transmissions	22
4.0 Trouble Shooting	23
4.1 Power Problems	23
4.2 Communications Problems	23
4.3 Commonly Asked Questions	24
4.4 Repair and Return Policies	25
5.0 Specifications	26
Function Key and LED Assignments	27
Function Key Insert Drawings	28
MMI-200, 210, 220, 240 Panel Cutout Template (1:1)	29
Warranty	30

About this Manual

This document is based on information available at the time of its publication. While efforts have been made to be accurate, the information in this document may not cover all details or variations in hardware or software, nor does it provide for every possibility in connection with installation, operation, or maintenance. Features may be described herein which are not present in all hardware. Kessler Ellis Products assumes no obligation of notice to holders of this document with respect to changes subsequently made.

Information in this document is subject to change without notice and does not represent a commitment on the part of Kessler Ellis Products.

Some common terms used:

PLC: Programmable Logic Controller. Typically, the MMI is connected to one of these devices. This is a generic term covering a large range of programmable devices used in machine control applications.

MTR: This stands for Message Triggering Register. The **MTR** is the register that holds the message number for the **MMI** to display.

Symbology



Warning! Indicates that the reader should pay special attention to the accompanying text. Precautionary steps should be taken to insure that the installation is in compliance with warnings. Warnings include hazardous conditions that could cause personal injury or equipment damage if care is not taken.

1.0 Getting Started

1.1 What is the MMI-2XX Series?

MMI-2XX Series MMI Units are operator interfaces for PLCs. They allow the operator to interact with the machine by displaying messages that are preloaded into them with a Personal Computer and/or turning on LED's. They have legendable keys which can be programmed to perform various functions for the operator.

Equipment

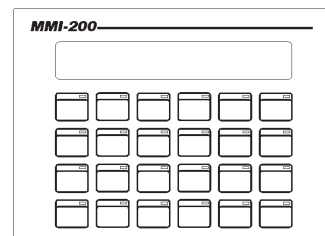
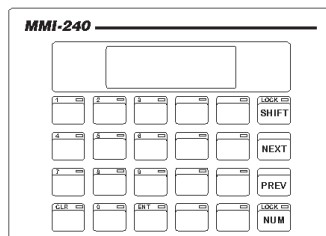

Checklist An MMI

system should include:

- An MMI-2XX Series base unit.
- An interface cable to the programmable controller.
- A personal computer with MMI programming software. A PC to MMI cable is required.

Designed For Use



Provides a convenient way for a machine operator to:

- View machine status and parameters.
- Change machine status or applicable operating parameters of the machine.
- Maintain the running of the machine.

It also gives enhanced capabilities to the machine through:

- RS232 ASCII output.
- Direct keypad interface.
- Visually displayed prompts.

1.1.1 The MMI Series and Its Environment

Where Used	The MMI Series is designed for use in a factory environment. They are designed to operate under the same temperature conditions as PLC's used in an industrial environment. They may not be suitable for use in certain outdoor applications. Please consult the factory for advised usage in outdoor applications.
NEMA Rating	The MMI-2XX Series front bezel is NEMA 4 rated. When installed properly in a NEMA 4 panel, the NEMA 4 rating of the panel will not be compromised. This means that fluids will not enter the panel during wash downs.
Electrical Environment	The DC powered MMI Series has been tested to conform to European CE requirements. This means that the MMI circuitry is designed to resist the effects of electrical noise. This does not guarantee noise immunity in severe cases. Proper wire routing and grounding will insure proper operation of the MMI unit.
Mechanical Environment	Avoid installing MMI units in environments where severe mechanical vibration or shock are present.
	
Caution!	Do not operate the MMI in areas subject to explosion hazards due to flammable gases, vapors or dusts.
	The MMI should not be installed where fast temperature variations and/or high humidity are present. This will cause condensation of water in the device.

2.0 Installation Instructions

2.1 Mounting Instructions

2.1.1 Location Considerations.



Care should be taken when locating equipment behind the MMI to ensure that AC power wiring, PLC output modules, contactors, starters, relays, and any other source of electrical interference are located away from the back of the unit.

Particular note should be taken to the position of variable speed drives and switching power supplies. Their input and load cables should be screened to a central star earth point.

2.1.2 Making a NEMA-4 Mounting.

Panel Details

The MMI can be mounted into panels with a depth of 3"(76mm). It is recommended that the MMI be mounted on the front panel of a steel enclosure, through a 7.1"(180mm) X 5.1"(129mm) opening. Allow a clearance of 1"(25mm) on each side of the cutout for clip mounting hardware. Allow clearance for cable connections to the bottom of the unit. Clearance may vary according to cable type used. Typically, plan a clearance to accommodate at least 3"(76mm) below the cutout.

Standard

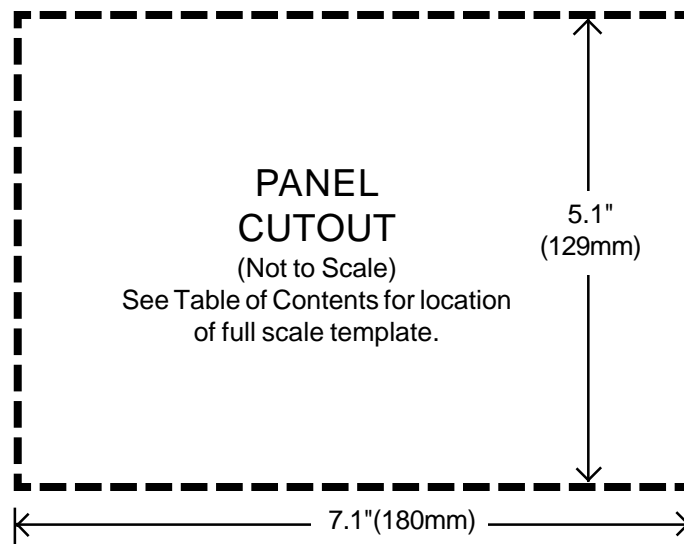

Mounting the panel cut out. Insert the clamps into the case. Pull back Put the MMI through on the clips until they seat into the retaining slots. Tighten clamping screws to 3 in.lb. of torque in an even pattern until the MMI is secured in the panel.

NEMA-4 Mounting Slide the gasket over the case so that it rests behind the Bezel Frame. Continue with standard mounting as described above. Avoid over tightening.

Specifications Note: To seal to NEMA-4 specifications, supplied gasket must be used and panel cannot flex more than 0.010". When a gasket is used, the gasket may be sealed to the case using an adhesive to maintain NEMA-4 rating.

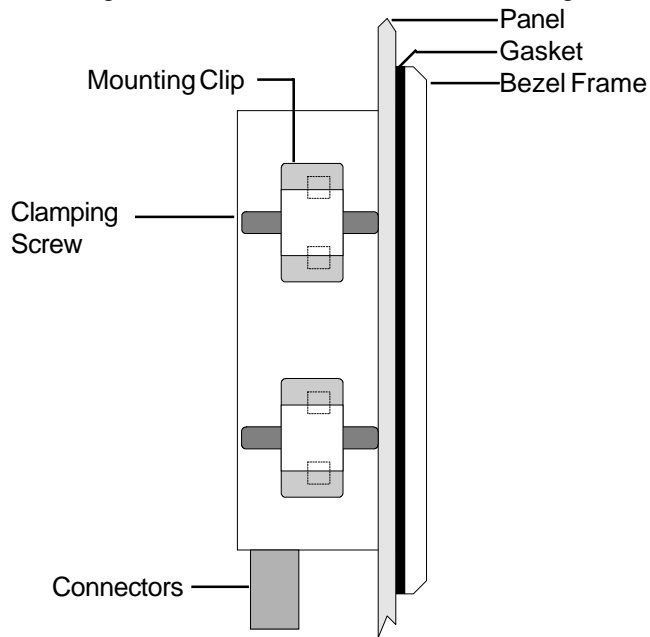

2.1.3 Environmental Considerations

- The MMI is to be used indoors as a built-in interface. Make sure that the unit is installed correctly and that the operating limits are followed (See Specifications).



- Do not operate the MMI in areas subject to explosion hazards due to flammable gases, vapors or dusts.

- The MMI should not be installed where fast temperature variations and/or high humidity are present. This will cause condensation of water in the device.

2.2 Power Connections

Make sure that all local and national electrical standards are met when installing the MMI. Contact your local authorities to determine which codes apply.

2.2.1 Power Requirements

Power

The MMI can be powered by AC or DC power, depending on the part number ordered. The MMI-2xx specified DC voltage range is +12 to 27 Volts DC. This insures compatibility with most DC systems. The MMI-2xxA can be powered by 115 VAC only. The MMI-2xxB can be powered by 230 VAC only. The power conditioning circuitry inside the unit is accomplished by a switching power supply. Due to the nature of switching power supplies, a wide range of over and under voltages may be used without adversely affecting the unit.

Fusing Requirements



The MMI-2XX series is fused internally with a self resetting 60V 400mA fuse. It is recommended that all input power lines be protected from product failure by a fuse or breaker. If the display does not come on within 2 seconds of power up, remove power. An internal diode will prevent damage if the polarity of the DC power is incorrect. Check wiring to insure proper connections and try to power up again.

Caution Strain Relief



Adequate strain relief must be provided for the power connector, to ensure that vibration or the disturbance of cables during maintenance does not cause the connector to pullout. Retention of the power cables by a tye-wrap onto the trunking, or an adhesive pad mounted tye-wrap point is normally suitable.

High Voltage Connecting high



Caution

voltages or AC power mains to the DC input will make the MMI unusable and may create an electrical shock hazard to personnel. Such a failure or shock could result in serious personal injury, loss of life and/or equipment damage.

DC voltage sources should provide proper isolation from main AC power and similar hazards.

Emergency Stop

A hard wired



Caution

EMERGENCY STOP should be fitted in any system using the MMI to comply with ICS Safety Recommendations.

**Caution
Supply Voltage
Condition**



Do not power the MMI and inductive DC loads, or input circuitry to the PLC, with the same power supply.

The 24 VDC output from some PLC's may not have enough current to power the DC powered MMI.

**Caution
Power Cycling**



Power supplies with large capacitive outputs may cause problems if power is cycled within a short time period. The power supply's capacitor will supply enough current to keep the microprocessor running for a few minutes but not enough to keep the display active. If full power is restored during that time, the microprocessor may not initialize the display module. The result is that the display will remain blank or show just the cursor in the upper left-hand corner and the rest of the unit will be fully functional.

To remedy this problem, run power to the unit through a "seal in" circuit or remove the capacitor (the MMI is not affected if power is unregulated) or wait sufficient time between power cycles.

**Caution
Wire Routing**



Wire lengths should be minimized (Maximum 1600' (500 m) shielded, 1000' (300 m) unshielded).

Wires should be run in pairs with a neutral or common paired with a hot or signal line.

If wiring is to be exposed to lightning or surges, use appropriate surge suppression devices.

Keep AC, high energy, and rapidly switching DC wiring separate from signal wires.

Equip ungrounded DC supplies with a resistor and capacitor in parallel to earth ground. This provides a path for static and high frequency dissipation. Typical values to use are 1M Ω and 4700pF.

**Terminal Block
Connections**

To make a connection, strip about 1/4" of insulation off the end of the wire, turn the connector screw counterclockwise until the gap is wide open, insert the wire all the way in, and turn the screw clockwise until it is tight.

For DC powered units, connect the positive DC line to terminal 3 and the DC ground to terminal 4. For AC powered units, connect the AC lines to terminals 3 and 4.

2.2.2 Grounding Requirements



Earth ground must be used. DC ground (Terminal 4) is not directly coupled to Earth ground internally. It is preferable not to ground DC negative return to earth ground, terminal 5, as poor site earths can introduce noise into a system, but if necessary an earth connection should be made, from the power supply return point to the central star earth point.

Ground conductors should be as short and as large in size as possible. The conductors must always be large enough to carry the maximum short circuit current of the path being considered. Ground conductors should be connected from a tree from a central star earth ground point. This ensures that no ground conductor carries current from any other branch.

2.2.3 CE Requirements (DC Powered MMI)

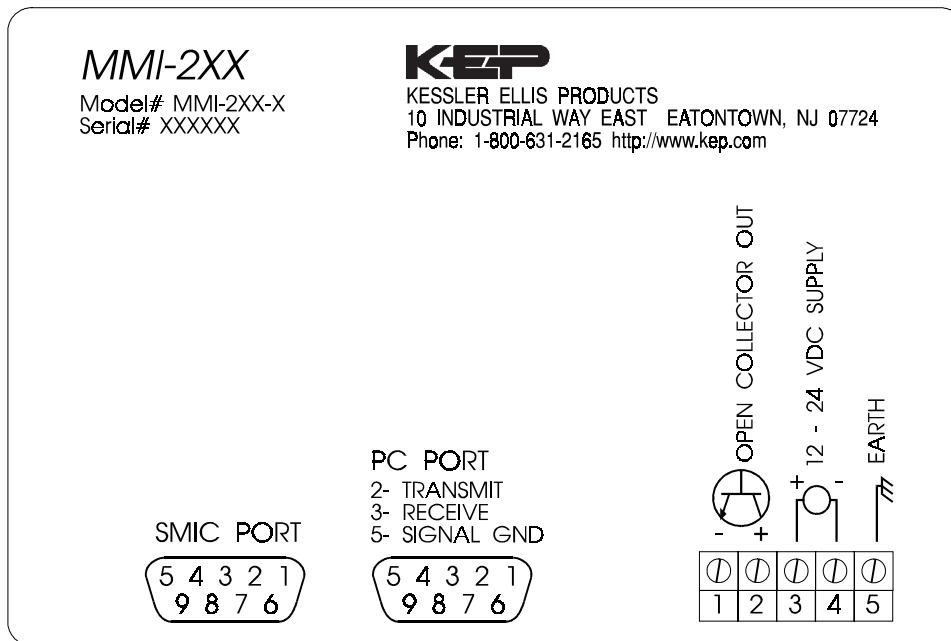

Typical Label on Rear of MMI-2XX Series unit showing connection points.

To make the DC powered MMI comply with EMC directives, and to reduce susceptibility to electrical interference, a separate #14 AWG ground wire should be taken to terminal 5 of the power connector. This ground connection should be run directly to the central star earth connection point (as recommended in most PLC Installation Instructions).

2.2.4 Safety Guidelines

This section presents recommended installation practices and procedures. Since no two applications are identical, these recommendations should be considered as guidelines.

Hardware Considerations
WARNING!



The system designer should be aware that control devices in Programmable Controller systems can fail and thereby create an unsafe condition. Furthermore, electrical interference in an operator interface, such as the MMI, can lead to equipment start-up, which could result in property damage and/or physical injury to the equipment operator.



If you, or your company, use any programmable control systems which require an operator or attendant, you should be aware that this potential safety hazard exists and take appropriate precautions. Although the specific design steps depend on your particular application, the following precautions generally apply to installation of solid-state programmable control devices. In addition, these precautions conform to the guidelines for installation of Programmable Controllers as recommended in the NEMA ICS 3-304 Programmable Control Standards.

Programming Considerations
To conform with ICS



Programming
Safety Recommendations, checks should be placed in the PLC program to ensure that all writable registers that control critical parts of plant or machinery should have upper and lower limit checks built into the program, with an out-of-limit safe shut down procedure to ensure safety of personnel.

ICS3-304.81 Safety Recommendations:

Consideration should be given to the use of an emergency stop function which is independent of the programmable controller.

Where the operator is exposed to the machinery, such as in loading or unloading a machine tool, or where the machine cycles automatically, consideration should be given to the use of an electromechanical override or other redundant means, independent of the programmable controller, for starting and interrupting the cycle.

If provision is required for changing programs while the equipment is in operation, consideration should be given to the use of locks or other means of assuring that such changes can be made only by authorized personnel.

These recommendations are intended as safeguards against the failure of critical components and the effects of such failures or the inadvertent errors that might be introduced if programs are changed while the equipment is in operation.*

* The ICS 3-304.81 Safety Recommendations are reproduced by permission of the National Electrical Manufacturers Association from NEMA ICS 3-304, Programmable Controller Standard.

2.3 Communications Connections

2.3.1 Connection to an External Device

The DB9 port farthest from the power connector as you look at the back of the case (labeled SMIC PORT) is the port for connecting to a PLC or external device using KEP's SMIC adaptor cables.

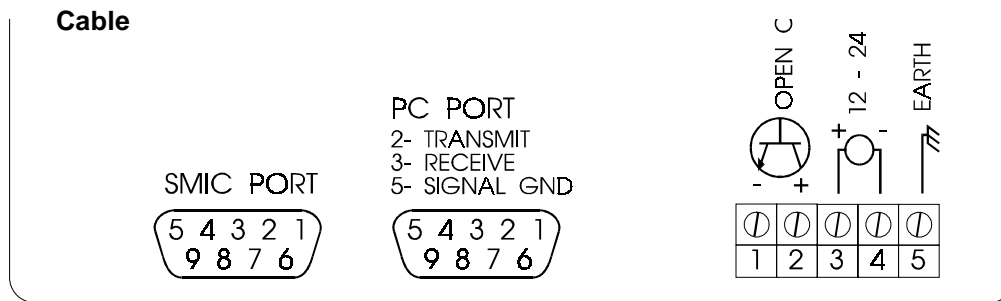

Requirements required for various devices. The KEP part numbers have the Different cables are SMIC prefix. Refer to a KEP catalog or datasheet for a complete listing of MMI-2XX compatible devices.

These cables can be obtained from the same distributor where you purchased the MMI-2XX.

Caution

Restrict cable length to less than 500' (150m) for RS485/422 devices and 50' (15m) for RS232 devices to avoid communications problems. Communications problems cause the MMI display to hold until communications can be established.



Shielded cable must be used for long lengths or cables run in an electrically noisy environment.

Do not run cables next to AC power lines or near sources of electrical noise.

Be sure that the cable ends have been inserted all of the way into mating connectors and are secure.

SMIC Port

Pin Designations the 9 pole SUB-D RS232 to external device port
 Pin assignment of

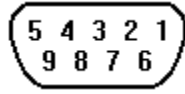

Pin#	Symbol	Function
1	Not used	
2	TxD	Transmitted Data
3	RxD	Received Data
4	Not used	
5	GND	Signal Ground
6	Vcc	DO NOT GROUND THIS PIN
7	Not used	
8	CTRL	Flow Control Line for RS485
9	RSV	DO NOT USE Reserved for MMI use

2.3.2 Connection to a Personal Computer

The 9 Pin Female connector closest to the power connector as you look at the back of the unit is the programming port (labeled PC PORT).

Connection

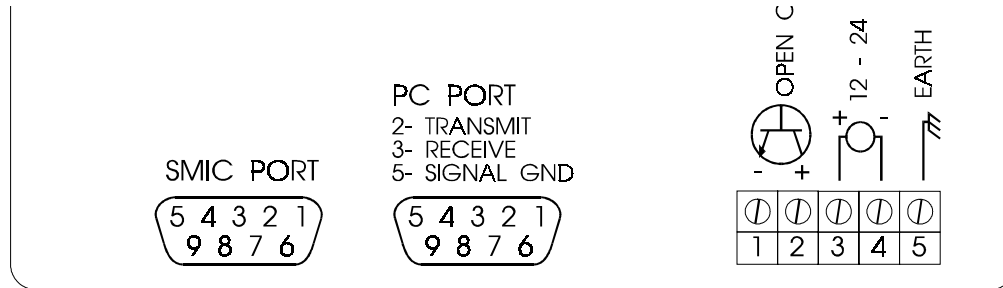

This port can be attached to a Computer via a DB9 Male to DB9 Female straight through cable. Make sure 2 and 3 are not reversed.

Port Activation

This port is always active. When Uploading and Downloading information to the PC, PLC operations are suspended.

Note: The PC Port is not a pass thru port to the PLC.

Print Out

The MMI-220 and 240 have print out capabilities. When a message is assigned to be sent out the serial port, the transmit line of the computer port becomes active momentarily.

PC Port

Pin Designations

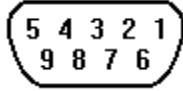

Pin assignment of the 9 pole SUB-D RS232 to Computer port

Pin#	Symbol	Function
1	Not used	
2	TxD	Transmitted Data
3	RxD	Received Data
4	Not used	
5	GND	Signal Ground
6	Not used	
7	Not used	
8	Not used	
9	Not used	

2.4 CE Requirements

2.4.1 EU directives that apply to the MMI-2XX (DC) Series:

- EMC Directive (89/336/EEC, 91/263/EEC, 92/31/EEC, 93/68/EEC) electromagnetic emissions and immunity

DC powered MMI products will be CE-marked to indicate compliance with the EMC Directive. Declarations of Conformity that specify the directive(s) and the catalog numbers of the products covered are available from Kessler Ellis Products.

Although the DC powered MMI-2XX products are CE compliant, it is the responsibility of the person who finally implements the system, that the machine (including other electrical and electronic devices) will meet the EMC requirements.

The DC powered MMI has been designed to operate satisfactorily in electromagnetic noise (immunity) and without emitting high levels of electrical noise into the environment (emission). The DC powered MMI was designed to meet European Community standards when installed per the wiring instructions in this manual.

Compatibility Standards

The DC powered MMI has been designed to meet

electromagnetic compatibility for industrial environments.

- CISPR (EN 55011) Group 1, Class A Radiated Emissions levels
- EN50081-2 Generic emission standard, industrial environment (Also US FCC Class A)
- EN50082-2 Generic immunity standard, industrial environment

2.4.2 General Installation Guide Lines for EU Installations.

- Be aware that wiring leaving the cabinet where the MMI is installed may be exposed to interference sources.
- The installation practices in the individual product installation manuals of other components in the system must also be followed.
- Locally applicable grounding safety regulations and machinery directives should be followed for providing a protective ground to earth. The EMC ground must be a low impedance, low inductance path to the machine chassis ground.
- The MMI power supply must be through an IEC-rated isolation transformer.
- The Power supply to the PLC must be controlled to ensure that it does not exceed overvoltage category II per EN60204-1 (IEC 240).
- Other requirements of the Machinery Directive involving displays, languages, instructions, Emergency Stop functions, machine operation, protective guards and interlocks are the responsibility of the machine manufacturer.

2.4.3 General Safety Guide Lines for EU Installations.

- Only qualified personnel should be allowed to specify, apply, install, operate, maintain or perform any other function related to MMI products. Qualified persons are defined as follows:
 - System application and design engineers who are familiar with the safety concepts of automation equipment. Installation, start-up, and service personnel who are trained to install and maintain automation equipment. Operating personnel trained to operate automation equipment and trained on the specific safety issues and requirements of the particular equipment.
- Before switching on the equipment, make sure that the voltage range for the equipment is correct.
- Emergency tripping devices in accordance with EN60204/IEC204 must be effective in all operating modes of the automation equipment. Resetting the emergency off device must not result in any uncontrolled or undefined restart of the equipment.
- Automation equipment and its operating elements must be installed so that unintentional operation is prevented.
- Make sure that operating sequences interrupted by a voltage dip or power supply failure resume proper operation when the power supply is restored. If necessary, the equipment must be forced into the “emergency off” state.
- Install the power supply and signal cables so that inductive and capacitive interference voltages do not affect automation functions.

3.0 MMI Operations

Once the MMI is programmed and connected to the PLC, normal operation begins. The MMI establishes communications with the PLC. It then requests the number in the Message Triggering Register (MTR), if used, and displays the corresponding message. It then requests the bit pattern in the LED Control Register and lights the corresponding LED's.

3.1 The Message Queue **MMI-220, 240**

Occasionally, messages are called up faster than they can be displayed. When this happens messages are held in a Queue and wait their turn to be displayed. The message Queue holds up to 3 message numbers.

3.1.1 Queue Activation

Messages are stored in the Queue when:

1. A series of Chained messages are being displayed.
2. A message with a long minimum display time is displayed.
3. A message with a long scrolling time is displayed.

3.1.2 Queue Action

The Queue is emptied on a first in, first out basis. If the Queue is full, additional messages will be lost.

Warning Function keys that have displayable message text assigned to them clear the Queue.

3.1.3 The Interrupt Message

Message number **65535** is the Interrupt message. When message 65535 is called, the Queue is immediately cleared. The next message number that appears in the message triggering register is then displayed.

An example of Queue operations:

Message 23 is being displayed with a minimum time of 10 seconds.

Display	Queue
23	—

During that period message numbers 34, 15 and then 211 are called for by the MTR.

Display	Queue
23	34
	15
	211

The MMI will put message 34, 15 and 211 in the Queue. When message 23 has timed out, message 34 will be called up and displayed.

Display	Queue
34	15
	211

When 34 is done, message 15 will be displayed.

Display	Queue
15	211

When 15 is done, message 211 will be displayed.

Display	Queue
211	EMPTY

Message 211 will continue to be displayed until a new message number is put in the MTR or a function key is pressed.

3.2 Using the Function Keys

Simply press a Function key to initiate their programmed action and/or call up their associated messages.

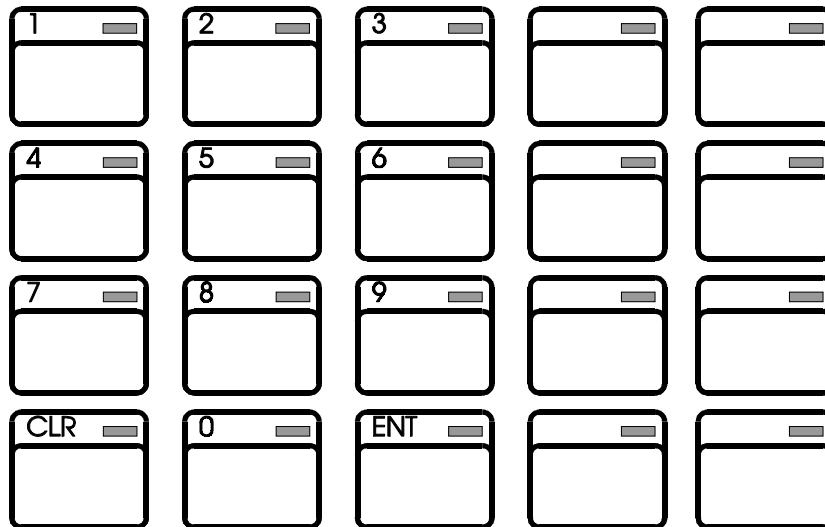

SHIFT KEY



The SHIFT key is used to activate shifted functions. Press the SHIFT key and the LOCK LED will light. This indicates that the function keys will perform their shifted function when pressed. To deactivate the SHIFT, press it again. The LOCK LED will go out indicating that the function keys are back to non-shifted functions. This feature is not available on the MMI-200.

When a function key is pressed, one of the following conditions will apply.

3.2.1 The Function key may have message text assigned to it, request the operator to edit a value or chain to another message.

1. The Function key message will interrupt the active display.

Note: Function keys with message text assigned to them clear the message Queue and interrupt minimum display times, chained and scrolling messages.

2. The message assigned to the Function key will be displayed.

3. At the end of a Function call and after all data entry and message chaining is done, the display does one of the 3 options listed in priority below.

A. Chains, if programmed, to the next message.

B. Displays the message whose number is next in the message Queue.

C. Displays the message whose number is in the MTR.

3.2.2 No message text is assigned to the Function key and no messages are chained to or from the Function key. The function key is assigned to download a constant or change a bit status only.

Press the Function key. The Queue is not cleared and the display is not interrupted but the function is carried out.

3.2.3 No message or action is assigned to the Function key.

When the Function key is pressed, nothing happens.

3.3 Entering Numerical Values

MMI-210

The MMI-210 displays synonyms with register values or bit status' which may be changed. The operator may change these values by the following procedure:



- Press the **NUM** key. The LOCK LED above the key will light. This indicates that the appropriate function keys will now act as a numeric keypad for data entry.
- If a password is required, enter it and press the **ENT** key.
- Key in the new data value, or use the 0 and 1 keys to change bit status.
- Press the **ENT** key. Only after the **ENT** key is pressed will the new value be written to the PLC.

To escape from entering a value, wait ten seconds. The MMI will time out and display the value that is in the register in the PLC. To return the function keys to function status, press the **NUM** key again. The LOCK LED will go out indicating the function keys are active once again.

MMI-220, 240



The MMI-220 and 240 may have data or bit status embedded in a message for the purpose of editing. Such data is usually machine status, setpoints or other setup parameters that may need to be changed from time to time. When a Special or Function key message with an embedded register Action Field is displayed, the value will flash, prompting the operator to input data.

The operator may change these values by using the same procedure as for the MMI-210 (see p.18), except the **NUM** key will already be active and the LOCK LED will be set ON.

Alternatively, the MMI-220 or 240 may be programmed to have the **NUM** key permanently active. If it has, the LOCK LED above the key will always be ON. This feature cannot be changed from the front panel. The operator may change data values by the following procedure:

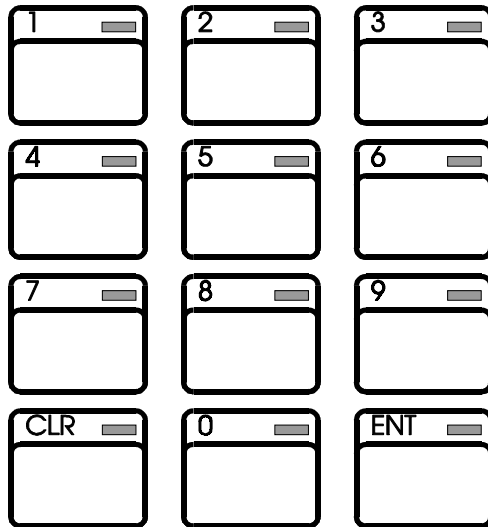

- The LOCK LED above the key will always be lit. This indicates that the appropriate function keys act as a numeric keypad for data entry only.
- Enter a password, if one has been assigned, and press the **ENT** key.
- Key in the new data value, or use the 0 and 1 keys to change bit status.
- Press the **ENT** key. Only after the **ENT** key is pressed will the new value be written to the PLC.

To escape from entering a value, wait ten seconds. The MMI will time out and display the value that is in the register in the PLC.

To program the **NUM** key to be permanently active, select the Lock Status in the Edit|Setup menu in **MMISoft** as NUM LOCK always active. This setting will turn on the LOCK LED above the **NUM** key and permanently activate the numeric keypad (0 to 9, CLR and ENT) for data entry. Function keys F1 to F12 (and corresponding shifted keys F21 to F32) will not be active and will be unavailable for function key use. They may only be used for numeric data entry.

MMI-200

The MMI-200 has no direct facility to allow the operator to enter operational parameters outside of function key download capabilities.

3.4 Using the PREV and NEXT keys

MMI-220, 240



The PREV and NEXT keys on the MMI-220 and 240 are used to step up or down through a pre-programmed list of messages called a **Link**. The list may be called up by putting the link message number in the MTR or by pressing a Function key. Once the link is active, the unit will display only messages from the link until a new message number or list is called by the MTR, or a Function Key is pressed.

When the last message of the link is displayed, the NEXT key brings you back to the beginning of the list. When the first message of the link is reached, the PREV key brings you back to the end of the list.

MMI-210

The PREV and NEXT keys on the MMI-210 are used to step up or down through a pre-programmed list of labeled registers or bits called synonyms. The list may be called up by pressing a Function key. Once the list is active, the unit will display only registers and bits from the list until a new list is called by a Function Key.

When the last synonym of the list is displayed, the NEXT key brings you back to the beginning of the list. When the first synonym of the list is reached, the PREV key brings you back to the end of the list.

3.5 Activating the Beeper

The MMI-2xx series contains a small internal beeper. To activate the beeper, a constant must be sent to a defined register in the PLC. Depending on the LED register chosen, the Beeper is controlled by the register directly after the LED register. This register is referred to as the LED Register+1, as described in the Specifications in Section 5.0.

For example, if the beeper needs to be sounded when an alarm condition occurs, a constant that turns on Bit 9 and Bit 10 should be sent to the LED Register+1. That means in Binary, a constant of 0000001100000000 may be used. This is equivalent to 300 in Hexadecimal or 768 in Decimal. To shut off the beeper, those bits should be turned off.

The beeper may also be set up to sound every time a key is depressed, giving user feedback of key presses. This is done in the Windows® based **MMISoft** setup software in the Edit|Setup menu. Clicking on the check box next to Beep Enable adds a check mark that enables the beeper and causes the beeper to sound every time a key is pressed. Clicking on the box again removes the check mark and disables the beeper. Note that the beeper may still be activated by using its control bits as described in the previous paragraph.

3.6 Activating the Open Collector Output

In addition to the beeper, the MMI-2xx series also contains an Open Collector Output. To use the Open Collector Output (O.C.), a constant must be sent to a defined register in the PLC. The Open Collector Output is a small transistor device that can be turned on to trip an external relay that could sound an external sounding device, etc. Please observe the current limits on the Open Collector Output, as described in the Specifications in Section 5.0.

For example, to turn on the O.C. Output, a constant that turns on Bit 11 and Bit 12 should be sent to the LED Register+1. That means in Binary, a constant of 0000110000000000 may be used. This is equivalent to C00 in Hex or 3072 in Decimal. To shut off the O.C. Output, those bits should be turned off.

The O.C. Output may also be set up to activate every time a key is depressed. This allows for user feedback of key presses in a noisy environment, if the O.C. Output is hooked to a local alarm. This is done in the Windows® based **MMISoft** setup software in the Edit|Setup menu. Clicking on the check box next to Open Collector adds a check mark that enables the O.C. Output and causes it to activate every time a key is pressed. Clicking on the box again removes the check mark and disables the O.C. Output. Note that the O.C. Output may still be activated by using its control bits as described in the previous paragraph.

3.7 Using the Keypad Download

The MMI-2xx series also allows the keypad to turn on a bit in a specific register in the PLC when a key is depressed. When keypad downloading is enabled and a key is pressed, the key's corresponding bit is turned ON in the PLC. When the key is released, the bit is restored to the OFF state.

Depending on the LED register chosen, the keypad status is downloaded to the second and third registers directly after the LED register. These registers are referred to as the LED Register+2 and LED Register+3 under Keypad Download in the Specifications in Section 5.0. See that section for the key to bit relationship.

To enable keypad download, use the Windows® based **MMISoft** setup software and select the Edit|Setup menu. Clicking on the check box next to Download Keypad adds a check mark that enables the keypad to be downloaded and causes it to turn a bit ON in the PLC every time a key is pressed. Clicking on the box again removes the check mark and disables the keypad download.

3.8 MMI Response

The MMI is limited in its response to key presses and information update by the serial communications to the PLC. The MMI has been optimized to provide reasonable response times to events.

3.8.1 Response Time to Message Calls, LED, Beeper and O.C. Output Activation

A message number must be in the MTR or bit sequence change in the LED register for at least 300 milliseconds to be recognized by the MMI.

3.8.2 Response Time to Function Key Presses

Function keys are handled on an interrupt basis. As soon as a key is pressed, a communication is sent to the PLC. Response to a key press by the PLC depends on the PLC's scan time and communications handling. Typically, response times are less than 1 second. We do not recommend using the function keys for JOGGING applications.

3.8.3 Response Time to Serial Port Transmissions

MMI-220, 240 When a called message has the attribute to be sent to the serial port, the MMI-2XX will send the message to the port before displaying it. Response time is determined by the number of registers/bits embedded in the message. The serial port baudrate also determines how long it will be before the message is displayed. A 200 character scrolling message with several embedded registers and bits sent out at 300 baud may take up to 10 seconds to appear on the display.

4.0 Trouble Shooting

4.1 Power Problems

Problems on power up

Unit does not light or unit lights but does not display any messages.

1. The MMI has a switching power converter in it. If the Power Supply voltage rises too slowly the converter does not get the “kick” it needs to start switching properly. If the power supply has a large capacitor, it may cause this problem. Remove the capacitor and try again. The MMI does not require strict power regulation.

2. Most electrical noise is present at start up when solenoids and motor starters activate. This may also cause a momentary brown out in power. To eliminate the effects of this on the MMI, use a delay relay (3 seconds) on the DC line providing power to the MMI. This will also prevent the problem of the power supply capacitor as well.

Problems during operation

Faulty operation of the MMI may be due to problems with power quality. The MMI has been designed to work in environments where electrical noise is present. However, extreme electrical noise will still cause problems. Make sure that the system is properly earth grounded.

4.2 Communications Problems

Sometimes communications fail. There are various reasons why this happens; electrical noise, loose cables, time outs, and power loss. When communications fail, the MMI tries to re-establish the communications link. During the time the MMI is establishing communications, the keypad of the MMI will not respond. Function key operations will be interrupted. The implication is that the MMI should not be used for Emergency Stop applications. A loss of communications can happen at any time. Using the function keys on the MMI for critical operations can lead to a potential disaster. It is good programming practice to allow for safe operation in the event of failure of the interface.

The use of proper grounding techniques will insure reliable communications. Make sure the PLC and the MMI are connected to good earth ground sites. This allows EMI (Electro-Magnetic Interference, commonly called electrical noise) to be channeled to ground where it can no longer disrupt electrical operations. Be sure to route communications cables in separate bundles and locations from AC power and control wiring. Do not run communications cables near solenoid and relay coils or AC and DC drive controllers. Care should also be taken to locate the MMI itself away from sources of EMI.

4.3 Commonly Asked Questions

Q. Can I have multiple MMI's connected to one Controller?

A. The ability to connect more than one MMI to a PLC depends on the type of serial interface the PLC has. PLCs with RS232 communications cannot be networked due to the nature of RS232 signal requirements. PLCs with RS485 or RS422 can be networked, but, not all of these PLCs support networking. The MMI supports networking on a limited number of PLCs.

Q. Can I download a recipe?

A. Yes. To do this chain Special messages together with the recipe values as constants. Do not assign any message text to these messages. The recipe download can then be activated by Function key or MTR.

Q. Can I Have My PC and MMI connected to the PLC at the same time?

A. No, there will be a conflict with communications. Note: The PC port is NOT a pass through port to the PLC.

Q. Do I need to change any jumpers to go from one PLC type to another?

A. No. The PLC type is determined by the driver that is downloaded into the MMI at programming time. Make sure the PLC Type matches the SMIC adaptor cable type.

Q. Is there any way to completely erase the MMI memory?

A. Yes. The MMI memory can be initialized by the following procedure.



Caution!

**All Message and Driver programming will be erased!
Make sure you want to do this!!!**

1. Remove power from the MMI.
2. Hold the lower most right and left-hand keys (the CLR and NUM keys for MMI-210, 220 and 240) down.
3. While holding the two keys down, apply power to the MMI.
4. When the MMI displays "INITIALIZING ALL MEMORY", you can release the keys. (The MMI-200 will begin to flash its LED's in sequence.)

The MMI must now be reprogrammed using the PC software.

Q. How do I change the Battery?

A. There is none! The MMI requires no routine maintenance.

Q. I have created a project for one type of PLC. Can I convert this project for use with another PLC type?

A. Yes! Simply start a New project and use the utility "PLC2PLC" in **MMISoft** setup software under the **Options|Launch Utilities** menu to reassign your tags to the new PLC registers.

4.4 Repair and Return Policies

The MMI is designed to provide years of trouble free service. The MMI is burned in for at least 24 hours and undergoes a full functional test before it is released by Quality Assurance for shipment.

The MMI is warranted for 12 months under normal use.

The MMI does not require any "Routine Maintenance" by the user. If a problem should occur, and all troubleshooting procedures have been exhausted, contact your local representative or distributor.



Use our Toll Free number to contact KEP if persistent problems are encountered.

Phone: 1-800-631-2165

If the product must be returned for any reason, be sure to call KEP and get a Return Material Authorization (RMA) number from Customer Service first.

5.0 Specifications

Power	MMI-2xx: 12 (320 mA) to 24 (160 mA) VDC (3.8 W) unregulated, Maximum voltage limits 8 to 30 VDC. MMI-2xxA: 115 VAC +10% 50/60Hz (36 mA) MMI-2xxB: 230 VAC +10% 50/60Hz (17 mA)
Open Collector Output	250 mA maximum at 3 to 36 VDC non-inductive load
Memory	MMI-200, 210, 220 (std): 8 K Byte EEPROM MMI-210(opt.), 220(opt.): 32 K Byte EEPROM MMI-240 (std.): 32 K Byte EEPROM
Temperature	VFD Type: 32 to 140 °F (0 to 60 °C) LCD Type: 32 to 122 °F (0 to 50 °C)
Display	MMI-200 - None MMI-210, 220 - Vacuum Fluorescent or backlit LCD; 2 Lines of 20 characters each; Character height is 0.2" MMI-240 - Vacuum Fluorescent or backlit LCD; 4 Lines of 20 characters each; Character height is 0.2"
PC Port Communications	Serial RS232 output during operation Selectable 7 or 8 bit; Odd, Even or No Parity; 1 Start; 1 Stop bit; No handshake; 300, 600, 1200, 2400, 4800, 9600 or 19200 Baud. Default PC Port Communications: 9600 Baud, 8 bits, Parity = None. Note: Serial PC Port communication specifications apply to MMI printer setup and do not affect PC to MMI or Controller to MMI communications.
SMIC Port Communications	RS232; SMIC Adapter cable required. Communications parameters are Controller dependent and use factory default settings of the specific PLC in use.
Bezel	Membrane Keypad with tactile feedback; Rated NEMA 4X (water tight) provided it is installed with gasket provided as per installation instructions.
Dimensions	Bezel: 6" H x 8" W Panel Cutout: 7.1"(180mm) W X 5.1"(129mm) H x 3.0"(76mm) D Clearance depth required below unit: approximately 3.0"(76mm) depending on cable connectors.

Bit Map for MMI LED, Beeper and Open Collector Output Control

LED Register	LED Register+1
Bit 1 - LED 1	Bit 1 - LED 17
Bit 2 - LED 2	Bit 2 - LED 18
Bit 3 - LED 3	Bit 3 - LED 19
Bit 4 - LED 4	Bit 4 - LED 20
Bit 5 - LED 5	Bit 5 - LED 21
Bit 6 - LED 6	Bit 6 - LED 22
Bit 7 - LED 7	Bit 7 - LED 23
Bit 8 - LED 8	Bit 8 - LED 24
Bit 9 - LED 9	Bit 9 - Beeper Enable
Bit 10 - LED 10	Bit 10 - Beeper Activate
Bit 11 - LED 11	Bit 11 - O.C. Enable
Bit 12 - LED 12	Bit 12 - O.C. Activate
Bit 13 - LED 13	Bit 13 - Not used
Bit 14 - LED 14	Bit 14 - Not used
Bit 15 - LED 15	Bit 15 - Not used
Bit 16 - LED 16	Bit 16 - Not used

MMI-200
only

Bit Map for MMI Keypad Download

LED Register+2	LED Register+3
Bit 1 - Key 1	Bit 1 - Key 17
Bit 2 - Key 2	Bit 2 - Key 18
Bit 3 - Key 3	Bit 3 - Key 19
Bit 4 - Key 4	Bit 4 - Key 20
Bit 5 - Key 5	Bit 5 - Key 21
Bit 6 - Key 6	Bit 6 - Key 22
Bit 7 - Key 7	Bit 7 - Key 23
Bit 8 - Key 8	Bit 8 - Key 24
Bit 9 - Key 9	Bit 9 - Not used
Bit 10 - Key 10	Bit 10 - Not used
Bit 11 - Key 11	Bit 11 - Not used
Bit 12 - Key 12	Bit 12 - Not used
Bit 13 - Key 13	Bit 13 - Not used
Bit 14 - Key 14	Bit 14 - Not used
Bit 15 - Key 15	Bit 15 - Not used
Bit 16 - Key 16	Bit 16 - Not used

MMI-200
only

Function Key and LED Assignments

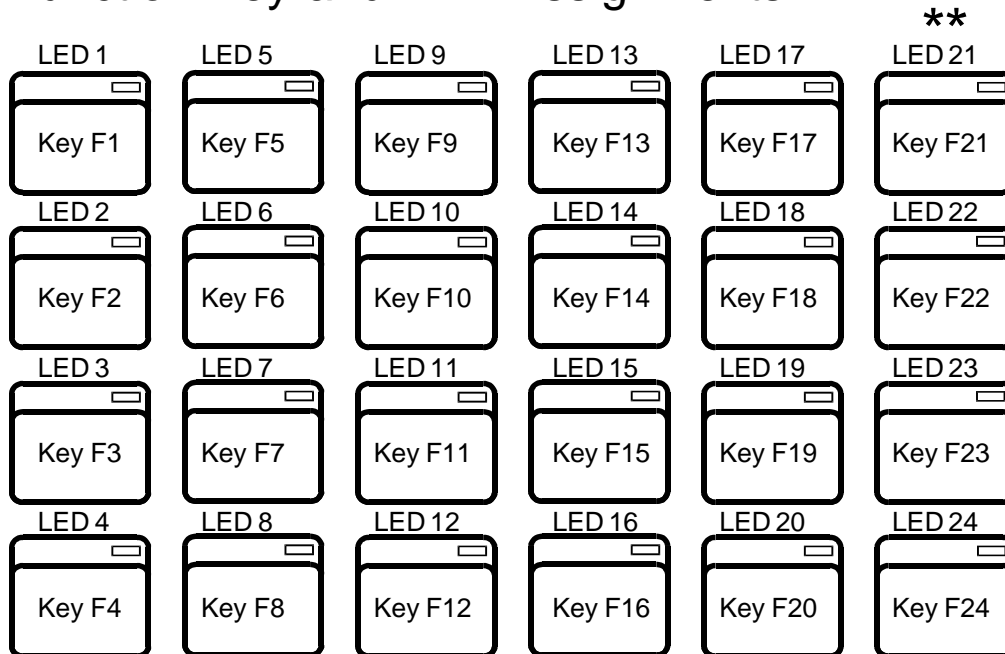

** Note: This column available on MMI-200 only.

MMI-200, 210, 220, 240 Function Key Insert

Drawing

Make copies onto 67 lb. card stock before using.

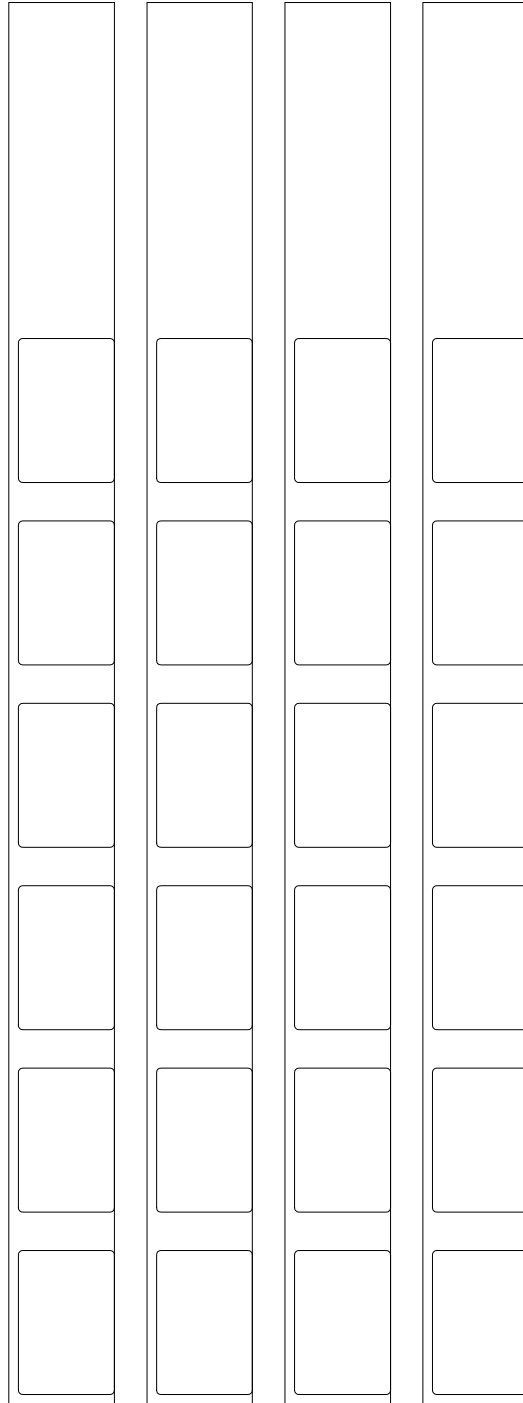

MMI-200, 210, 220, 240 Panel Cutout Template (1:1)

Make copies before using.

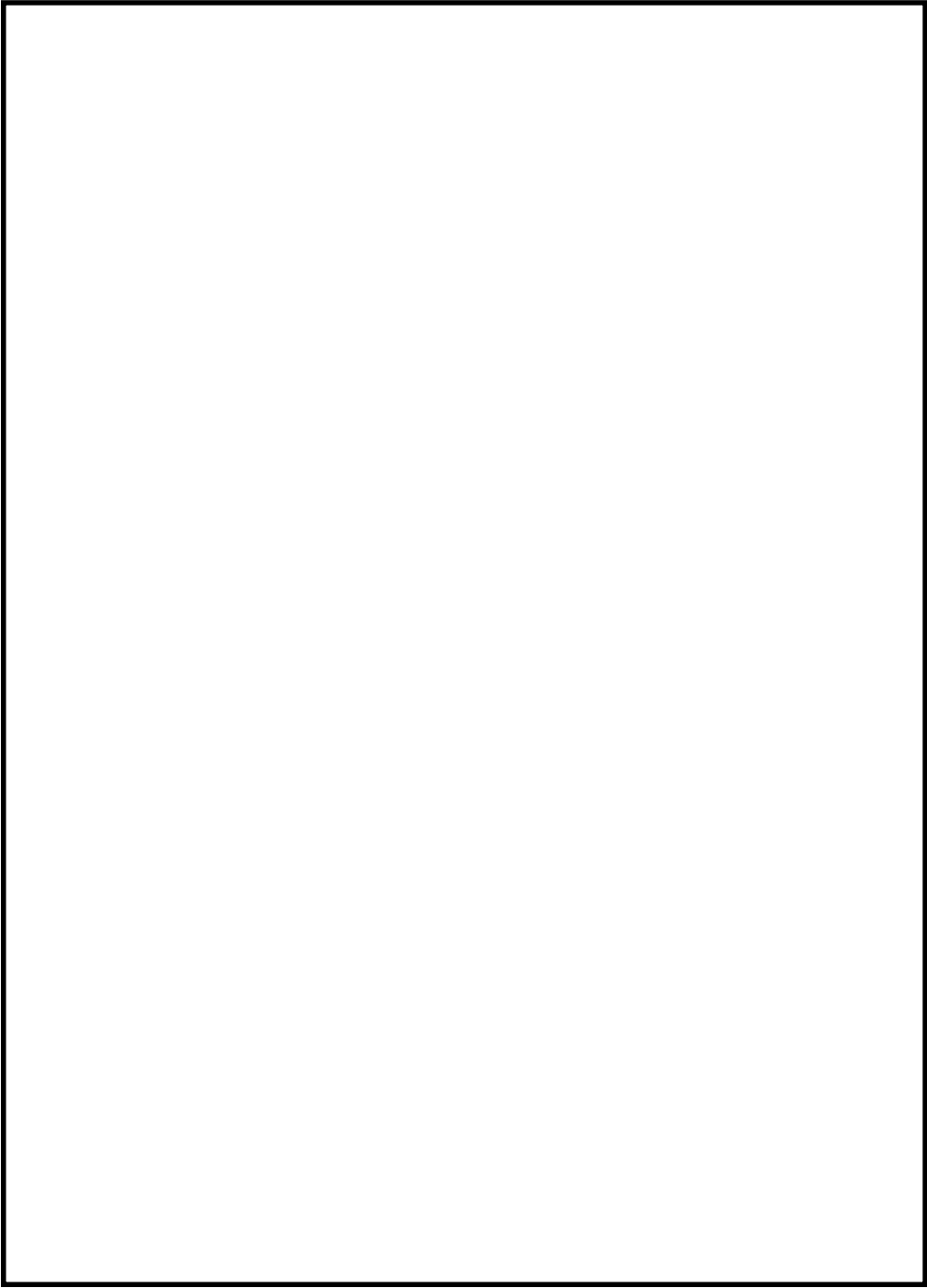



Artisan Technology Group is your source for quality new and certified-used/pre-owned equipment

- FAST SHIPPING AND DELIVERY
- TENS OF THOUSANDS OF IN-STOCK ITEMS
- EQUIPMENT DEMOS
- HUNDREDS OF MANUFACTURERS SUPPORTED
- LEASING/MONTHLY RENTALS
- ITAR CERTIFIED SECURE ASSET SOLUTIONS

SERVICE CENTER REPAIRS

Experienced engineers and technicians on staff at our full-service, in-house repair center

*InstraView*SM REMOTE INSPECTION

Remotely inspect equipment before purchasing with our interactive website at www.instraview.com ↗

WE BUY USED EQUIPMENT

Sell your excess, underutilized, and idle used equipment. We also offer credit for buy-backs and trade-ins. www.artisanng.com/WeBuyEquipment ↗

LOOKING FOR MORE INFORMATION?

Visit us on the web at www.artisanng.com ↗ for more information on price quotations, drivers, technical specifications, manuals, and documentation

Contact us: (888) 88-SOURCE | sales@artisanng.com | www.artisanng.com