



Artisan Technology Group is your source for quality new and certified-used/pre-owned equipment

- FAST SHIPPING AND DELIVERY
- TENS OF THOUSANDS OF IN-STOCK ITEMS
- EQUIPMENT DEMOS
- HUNDREDS OF MANUFACTURERS SUPPORTED
- LEASING/MONTHLY RENTALS
- ITAR CERTIFIED SECURE ASSET SOLUTIONS

SERVICE CENTER REPAIRS

Experienced engineers and technicians on staff at our full-service, in-house repair center

*InstraView*SM REMOTE INSPECTION

Remotely inspect equipment before purchasing with our interactive website at www.instraview.com ↗

WE BUY USED EQUIPMENT

Sell your excess, underutilized, and idle used equipment. We also offer credit for buy-backs and trade-ins. www.artisanng.com/WeBuyEquipment ↗

LOOKING FOR MORE INFORMATION?

Visit us on the web at www.artisanng.com ↗ for more information on price quotations, drivers, technical specifications, manuals, and documentation

Contact us: (888) 88-SOURCE | sales@artisanng.com | www.artisanng.com

Model 3150

High Power Temperature Controller

User's Manual



Certificate No.: FM 27207

Newport Corporation, Irvine, California, has been certified compliant with ISO 9002 by the British Standards Institution.



Corporate Headquarters Newport Corporation 1791 Deere Avenue Irvine, CA 92714 Telephone: 949-863-3144 Facsimile: 949-253-1800 Belgium Telephone: 016-402927 Facsimile: 016-402227	Canada Telephone: 905-567-0390 Facsimile: 905-567-0392 France Telephone: 1-60 91 68 68 Facsimile: 1-60 91 68 69 Germany Telephone: 06151-36 21-0 Facsimile: 06151-36 21-52	Italy Telephone: 02-924-5518 Facsimile: 02-923-2448 Japan Telephone: 03-5379-0261 Facsimile: 03-5379-0155	Netherlands Telephone: 030-6592111 Facsimile: 030-6570242 Switzerland Telephone: 01-740-2283 Facsimile: 01-740-2503	Taiwan R.O.C. Telephone: 2-2769-9796 Facsimile: 2-2769-9638 United Kingdom Telephone: 01635-521757 Facsimile: 01635-521348
---	---	--	--	---

Limited Warranty

Newport warrants that this product will be free from defects in materials and workmanship for a period of two years from the date of shipment. If any such product proves defective during the applicable warranty period, Newport, at its option, either will repair the defective product without charge for parts and labor or will provide a replacement in exchange for the defective product.

In order to obtain service under this warranty, the customer must notify Newport of the defect before the expiration of the warranty period and make suitable arrangements for the performance of service. In all cases the customer will be responsible for packaging and shipping the defective product back to the service center specified by Newport, with shipping charges prepaid. Newport shall pay for the return of the product to the customer if the shipment is within the continental United States, otherwise the customer shall be responsible for all shipping charges, insurance, duties and taxes, if the product is returned to any other location.

This warranty shall not apply to any defect, failure or damage caused by improper use or failure to observe proper operating procedures per the product specification or operators manual or improper or inadequate maintenance and care. Newport shall not be obligated to furnish service under this warranty 1) to repair damage resulting from attempts by personnel other than Newport's representatives to repair or service the product; 2) to repair damage resulting from improper use or connection to incompatible equipment; 3) to repair damage resulting from operation outside of the operating or environmental specifications of the product.

THIS PRODUCT IS NOT DESIGNED FOR USE IN MEDICAL INSTRUMENTS WHERE MALFUNCTION OF SUCH PRODUCTS CAN REASONABLY BE EXPECTED TO RESULT IN PERSONAL INJURY OR DEATH.

NEWPORT'S LIABILITY FOR THE MERCHANTABILITY AND USE OF THE PRODUCT IS EXPRESSLY LIMITED TO ITS WARRANTY SET OUT ABOVE. THIS DISCLAIMER AND LIMITED WARRANTY IS EXPRESSLY IN LIEU OF ANY AND ALL REPRESENTATIONS AND WARRANTIES EXPRESS OR IMPLIED, INCLUDING BUT NOT LIMITED TO, ANY IMPLIED WARRANTY OF MERCHANTABILITY OR OF FITNESS FOR PARTICULAR PURPOSE, WHETHER ARISING FROM STATUTE, COMMON LAW, CUSTOM OR OTHERWISE. THE REMEDY SET FORTH IN THIS DISCLAIMER AND LIMITED WARRANTY SHALL BE THE EXCLUSIVE REMEDIES AVAILABLE TO ANY PERSON. NEWPORT SHALL NOT BE LIABLE FOR ANY SPECIAL, DIRECT, INDIRECT, INCIDENTAL OR CONSEQUENTIAL DAMAGES RESULTING FROM THE USE OF THIS PRODUCT OR CAUSED BY THE DEFECT, FAILURE OR MALFUNCTION OF THIS PRODUCT, NOR ANY OTHER LOSSES OR INJURIES, WHETHER A CLAIM FOR SUCH DAMAGES, LOSSES OR INJURIES IS BASED UPON WARRANTY, CONTRACT, NEGLIGENCE, OR OTHERWISE. BY ACCEPTING DELIVERY OF THIS PRODUCT, THE PURCHASER EXPRESSLY WAIVES ALL OTHER SUCH POSSIBLE WARRANTIES, LIABILITIES AND REMEDIES. NEWPORT AND PURCHASER EXPRESSLY AGREE THAT THE SALE HEREUNDER IS FOR COMMERCIAL OR INDUSTRIAL USE ONLY AND NOT FOR CONSUMER USES AS DEFINED BY THE MAGNUSON-MOSS WARRANTY ACT OR SIMILAR STATE CONSUMER WARRANTY STATUTE.

©1996, Newport Corporation
Irvine, California, USA
Part No. 24594-01
IN-08972
Rev. C
Printed 11-Apr-00

EC DECLARATION OF CONFORMITY

Model 3150 High Power Temperature Controller

We declare that the accompanying product, identified with the “**CE**” mark, meets all relevant requirements of Directive 89/336/EEC and Low Voltage Directive 73/23/EEC.

Compliance was demonstrated to the following specifications:

EN50081-1 EMISSIONS:

Radiated and conducted emissions per EN55011, Group 1, Class A

EN50082-1 IMMUNITY:

Electrostatic Discharge per IEC 1000-4-2, severity level 3

Rated Emission Immunity per IEC 1000-4-3, severity level 2

Fast Burst Transients per IEC 1000-4-4, severity level 3

Surge Immunity per IEC 1000-4-5, severity level 3

IEC SAFETY:

Safety requirements for electrical equipment specified in IEC 1010-1.

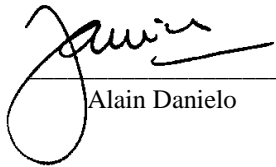

Alain Daniello

VP European Operations
Zone Industrielle
45340 Beaune-la-Rolande, France

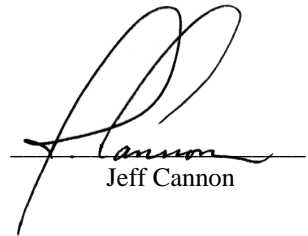

Jeff Cannon

General Manager-Precision Systems
1791 Deere Avenue
Irvine, Ca. USA

Table of Contents

1	General Information	1
1.1	Introduction	1
1.2	Product Overview	1
1.3	Available Options and Accessories	2
1.4	Safety Terms and Symbols	2
1.4.1	Terms	2
1.4.2	Symbols	3
1.5	General Warnings and Cautions	3
2	System Operation	5
2.1	Introduction	5
2.2	Installation	5
2.2.1	AC Power Considerations	5
2.2.2	Tilt-Foot Adjustment	5
2.2.3	Rack Mounting	6
2.2.4	Ventilation Requirements	6
2.2.5	Power-Up Sequence	6
2.2.6	Quick Start	6
2.3	Introduction to the 3150 Front Panel	7
2.3.1	Model 3150	7
2.4	General Operation	8
2.4.1	Display Elements	8
2.4.1.1	Static Fields	8
2.4.1.2	Non-Editable Data Fields	8
2.4.1.3	Editable Data Fields	8
2.4.1.3.1	Changing Data Fields	8
2.4.1.4	Soft Keys	9
2.4.2	Function Keys	9
2.4.3	Menu Structure	10
2.4.4	Master Display	11
2.4.5	Main Menu	11
2.4.6	Configure Menu	12
2.4.7	System Configure Screen	12
2.4.8	Save/Recall Screen	14
2.4.9	Calibration Screen	14
2.4.10	Configure Communications Screen	14
2.4.10.1	Error Message Control	15
2.5	Rear Panel Familiarization	15
2.5.1	GPIB Connector	15

2.5.2	RS-232 Connector	15
2.5.3	Input Power Connector	15
2.5.4	Ground Post	16
2.6	Warm Up and Environmental Consideration	16
3	Temperature Controller Operation	17
3.1	General Features	17
3.2	TEC Safety Features	17
3.2.1	Conditions Which Will Automatically Shut Off the TEC Output	17
3.3	The TEC Connectors	18
3.3.1	TEC Interlock	18
3.3.2	TEC Grounding Consideration	18
3.4	TEC Operation	18
3.4.1	TEC Main Screen	18
3.4.2	TEC Setup Screen	19
3.4.2.1	The ▲ and ▼ Soft Keys	20
3.4.2.2	Sensor (Sens)	20
3.4.2.3	Mode	21
3.4.2.3.1	Constant Temperature Mode (Const T)	21
3.4.2.3.2	Constant Resistance/Reference Mode (Const R)	21
3.4.2.3.3	Constant Current Mode (Const Ite)	21
3.4.2.3.4	Effects of Calibration on TEC modes	21
3.4.2.4	Gain	22
3.4.2.5	Limits	22
3.4.2.5.1	TE Current Limit (Lim Ite)	22
3.4.2.5.2	Temperature Limits (Lim Th and Lim Tl)	23
3.4.2.5.3	Resistance/Reference Limits (Lim Rh/vhI/ih and Lim Rl/vlO/il)	23
3.4.2.6	Tolerances (Tol Time and Tol Temp)	23
3.4.2.7	Vpow, Ths, and Tamb	23
3.4.2.8	C1, C2, C3, and Ro	23
3.4.3	Thermistor and Thermistor Current Selection	24
3.4.3.1	Introduction	24
3.4.3.2	Thermistor Range	24
3.4.3.3	Temperature Resolution	25
3.4.3.4	Selecting Thermistor Current	26
3.4.3.5	Selecting Thermistors	26
3.4.3.6	The Steinhart-Hart Equation	27
3.4.3.7	Table of Constants	29
3.4.4	AD590 and LM335	29
3.4.4.1	General	29
3.4.4.2	AD590 Sensor	29
3.4.4.3	LM335 Sensor	30
3.4.4.4	Determining C1 and C2 for the AD590 and LM335	31
3.4.4.4.1	One Point Calibration Method	31
3.4.4.4.2	Two Point Calibration Method	32

3.4.5	RTD Sensors	33
3.4.5.1	RTD Constants	33
4	<i>Principles of Operation</i>	35
4.1	Introduction	35
4.2	TEC Controller Theory of Operation	36
4.2.1	TEC Interface	36
4.2.2	Limit DAC	36
4.2.3	Set Point DAC	37
4.2.4	A/D Converter	37
4.2.5	Sensor Select	37
4.2.6	Difference Amplifier	37
4.2.7	Proportional Amplifier	37
4.2.8	Integrator	37
4.2.9	Bipolar Output Stage	38
4.2.9.1	Current Limiting	38
4.2.9.2	Current Limit Condition Sensing	38
4.2.9.3	Voltage Controlled Current Source	38
4.2.9.4	Voltage Limit Condition Sensing	38
4.2.10	TEC Control Modes	38
4.2.10.1	T Mode	38
4.2.10.2	R Mode	39
4.2.10.3	I _{TE} Mode	39
4.3	Microprocessor Board	40
4.3.1	Microprocessor	40
4.3.2	Memory	41
4.3.3	Serial Interface	41
4.3.4	Front Panel Interface	41
4.3.5	GPIB Interface	41
4.4	Power Supplies	41
4.4.1	TEC Power Supplies	41
4.4.2	Main Supply	42
5	<i>Tips and Techniques</i>	43
5.1	Introduction	43
5.2	TEC Limits	43
6	<i>Maintenance</i>	45
6.1	Introduction	45
6.2	Fuse Replacement	45
6.3	Cleaning	45
7	<i>Calibration</i>	47

7.1	Calibration Overview	47
7.1.1	Environmental Conditions	47
7.1.2	Warm-Up	47
7.2	TEC Calibration	47
7.2.1	Recommended Equipment	47
7.2.2	Local Operation Thermistor Calibration	48
7.2.3	Remote Operation Thermistor Calibration	48
7.2.4	Local Operation AD590 Sensor Calibration	49
7.2.5	Remote Operation AD590 Sensor Calibration	49
7.2.6	Local Operation LM335 Sensor Calibration	50
7.2.7	Remote Operation LM335 Sensor Calibration	50
7.2.8	Local Operation RTD Calibration	51
7.2.9	Remote Operation RTD Calibration	51
7.2.10	RTD Lead Resistance Calibration (Offset Null)	51
7.2.11	Local Operation ITE Current Calibration	52
7.2.12	Remote Operation ITE Current Calibration	52
8	Factory Service	55
8.1	Introduction	55
8.2	Obtaining Service	55
9	Error Messages	59
9.1	Introduction	59
10	Specifications	61
10.1	Temperature Controller Specifications	61
10.2	General Specifications	62

Tables

<i>Table 1 - TEC Connector Pinout</i>	<i>18</i>
<i>Table 2 - Comparison of Curve Fitting Equations</i>	<i>28</i>
<i>Table 3 - Thermistor Constants</i>	<i>29</i>
<i>Table 4 - RTD Constants</i>	<i>33</i>
<i>Table 5 - Recommended Test Equipment</i>	<i>48</i>
<i>Table 6 - Error Codes</i>	<i>59</i>

Figures

<i>Figure 1 - Model 3150 Front Panel</i>	<i>7</i>
<i>Figure 2 - A Sample Screen with Various Data Fields</i>	<i>9</i>
<i>Figure 3 - Model 3150 Menu Structure</i>	<i>10</i>
<i>Figure 4 - Master Display</i>	<i>11</i>
<i>Figure 5 - Main Menu</i>	<i>12</i>
<i>Figure 6 - Configure Menu</i>	<i>12</i>

<i>Figure 7 - Save/Recall Screen</i>	14
<i>Figure 8 - Communications Screen</i>	14
<i>Figure 9 - Rear Panel</i>	15
<i>Figure 10 - TEC Main Screen</i>	19
<i>Figure 11 - TEC Setup Screens</i>	20
<i>Figure 12 - Thermistor Temperature Range</i>	25
<i>Figure 13 - Thermistor Resistance versus Temperature</i>	28
<i>Figure 14 - AD590 Nonlinearity</i>	30
<i>Figure 15 - 3150 Block Diagram</i>	35
<i>Figure 16 - TEC Board Diagram</i>	36
<i>Figure 17 - Microprocessor Board Block Diagram</i>	40
<i>Figure 18 - Power Supply Block Diagram</i>	41

1 General Information

1.1 Introduction

This chapter describes the features, options, accessories, and specifications of the Model 3150.

1.2 Product Overview

PRODUCT FEATURES

- GPIB/IEEE 488.2 and RS-232C Interfaces
- Temperature Controller
 - 350 Watt (up to 15A, and up to 28V, but not more than 350 Watts)
 - Ultra stable bipolar output
 - Thermistor, AD590, LM335, and Pt RTD sensors

The Model 3150 Temperature Controller is a result of Newport's continuing commitment to provide advanced instrumentation at affordable prices.

High Power Temperature Controller Fulfills All Your Thermo Electric (TE) Cooling Needs

The 350 Watt Temperature Controller is offered to meet your most demanding TE cooling needs. It may be operated in one of three modes:

- Constant Temperature
- Constant Resistance
- Constant TE Current

Short term stability is better than 0.0005°C while long term stability is better than 0.001°C. Four sensor types are compatible with this TEC:

- Thermistors
- AD590 series
- LM335 series
- 100Ω Platinum RTDs

With the sensor's calibration constants, the actual temperature is displayed in °C on the front panel.

Intuitive Controls and LCD Display Simplify Control and Test Procedures

Improved data presentation and system control are achieved using a LCD display. A MASTER display shows the entire system configuration as well as TEC status. “Soft Keys” guide you through initial system setup routines and operation. Real-time control of an output is accomplished either by entering the set point via the cursor keys or control knob. MENU and FUNC keys access saved system configurations and repetitive procedures. All controls are clearly marked and instructions easily understood for simple operation.

GPIB/IEEE-488.2 and RS232 Interfaces Gives Power to Remotely Control and Collect Data.

For ultimate control a GPIB/IEEE-488.2 interface is available. All control and measurement functions are accessible via the GPIB interface. In addition, a standard serial RS-232C port allows simpler interfacing to a PC. As your instrumentation needs change the Model 3150 Temperature Controller will adapt to all your new applications giving you the ultimate in flexible laboratory equipment.

1.3 Available Options and Accessories

Accessories

3150-02	Temperature Controller Cable
3150-04	Temperature Controller/Mount Cable
300-16	10.0 k Ω thermistor ($\pm 0.2^{\circ}\text{C}$)
300-22	AD592CN IC Sensor
3150-RACK	Rack Mount Kit

Newport Corporation also supplies temperature controlled mounts and other accessories. Please consult with your representative for additional information.

1.4 Safety Terms and Symbols

1.4.1 Terms

The following safety terms are used in this manual:

The **WARNING** heading in this manual explains dangers that could result in personal injury or death.

The **CAUTION** heading in this manual explains hazards that could damage the instrument.

In addition, a **NOTE** heading gives information to the user that may be beneficial in the use of this instrument.

1.4.2 Symbols

The following symbols are used in this manual and on the instrument:



Power Off



Power On



Refer to the documentation.



Earth Ground

1.5 General Warnings and Cautions

The following general warning and cautions are applicable to this instrument:

WARNING

This instrument is intended for use by qualified personnel who recognize shock hazards or laser hazards and are familiar with safety precautions required to avoid possible injury. Read the instruction manual thoroughly before using, to become familiar with the instrument's operations and capabilities.

WARNING

The American National Standards Institute (ANSI) states that a shock hazard exists when probes or sensors are exposed to voltage levels greater than 42 VDC or 42V peak AC. Do not exceed 42V between any portion of the Model 3150 (or any attached detector or probe) and earth ground or a shock hazard will result.

CAUTION

There are no serviceable parts inside the Model 3150. Work performed by persons not authorized by Newport Corporation may void the warranty. For instructions on obtaining warranty repair or service please refer to Chapter 8 of this manual.

2 System Operation

2.1 Introduction

This chapter describes how to operate the Model 3150. Unless otherwise noted, “3150” refers to the Model 3150.

2.2 Installation

CAUTION

Although ESD protection is designed into the 3150, operation in a static-free work area is recommended.

2.2.1 AC Power Considerations

The 3150 can be configured to operate at a nominal line voltage of 100, 120, 220, or 240 VAC. Normally, this is done at the factory and need not be changed before operating the instrument. However, be sure that the voltage setting is correct on the power input module and correct fuses are installed per section 6.2 before connecting to an AC source. The 3150 is shipped set for 120 VAC and a caution sticker is placed on the input power connector.

CAUTION

Do not exceed 250VAC on the line input.

Do not operate with a line voltage that is not within $\pm 10\%$ of the line setting. Too low of an input voltage may cause excessive ripple on the DC supplies. Too high of an input voltage will cause excessive heating.

WARNING

To avoid electrical shock hazard, connect the instrument to properly earth-grounded, 3-prong receptacles only. Failure to observe this precaution can result in severe injury or death.

2.2.2 Tilt-Foot Adjustment

The 3150 has front legs that extend to make it easier to view the LCD display. To use them, place the 3150 on a stable base and rotate the legs downward until they lock into position.

2.2.3 Rack Mounting

The 3150 may be rack mounted by using a 3150 rack mount kit. All rack mount accessory kits contain detailed mounting instructions.

2.2.4 Ventilation Requirements

Rear panel area needs 2 to 4 inches of clearance for air circulation.

2.2.5 Power-Up Sequence

With the 3150 connected to an AC power source, set the power switch to “**I**” to supply power to the instrument and start the power-up sequence.

During the power-up sequence, the following takes place. For about 5 seconds an initialization screen is displayed. The software version is displayed in the lower left corner of the screen. During this time a self-test is performed to ensure that the 3150 hardware and software are communicating. If the 3150 cannot successfully complete this test, an error message will be displayed.

NOTE

In the even the 3150 is powered off, it must remain off for a **minimum of 60 seconds** before reapplying power. Not doing so may result in the internal power supply failing to start, and an error message will be reported. There is no risk of damage to the unit if such a condition occurs.

After this test, the 3150 is configured to the state it was in when the power was last shut off and displays the master display.

2.2.6 Quick Start

After the power-on sequence is complete, the 3150 goes to the Master screen. To set up the TEC, press the **SETUP** softkey button. The up and down cursor keys will allow the selection of all the TEC parameters, using the cursor keys and the dial set the parameter values. When finished, return the TEC to the Master screen by pressing the **MASTER** button.

Enter the desired set point value using the cursor keys or the dial. Press the **TEC On** key to operate the TEC. The LED illuminates to indicate TEC operation. To turn the TEC off, press the **TEC On** key again.

2.3 Introduction to the 3150 Front Panel

2.3.1 Model 3150

Described below are the functions of each area of the Model 3150 front panel, as shown in Figure 1.

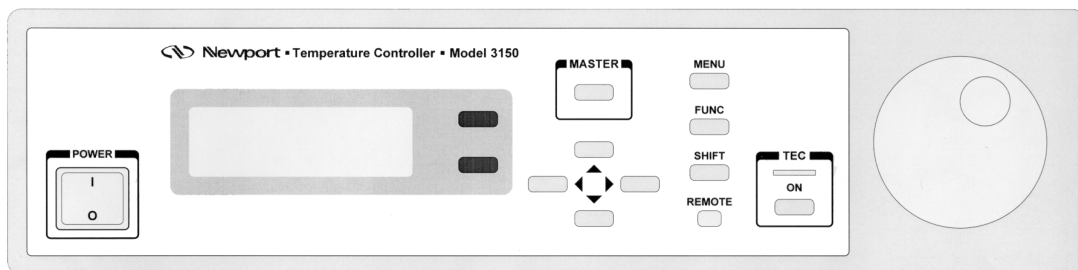

Figure 1 - Model 3150 Front Panel

1. **Power On/Off Switch** - Switches on/off the AC power to the unit.
2. **TEC On LED** - Indicates TEC output is on.
3. **TEC On Button** - Turns the TEC output on/off.
4. **Display Soft Keys** - These are the two dark keys located to the right of the display. The function of these keys varies depending on what menu is displayed. See section 2.4.1.4 for a complete description of soft keys.
5. **MASTER Key** - switches to the master display from any screen in the system (see section 2.4.4).
6. **Cursor Control Keys** - Moves cursor up or down between editable data fields. The left arrow decrements values in numerical entry fields, or as a previous choice in a multi-choice entry field. The right arrow increments values in numerical entry fields, or as a next choice in multi-choice entry fields. See section 2.4.1.3 for a description of data fields.
7. **MENU Key** - Switches to the main menu from any screen in the system (see section 2.4.5).
8. **FUNCTION Key** - Used to execute user macros and special functions (see section 2.4.2).
9. **SHIFT Key** - Toggles between the outer and inner set of soft keys (see section 2.4.1.4).
10. **Remote LED** - Indicates 3150 is in remote mode.
11. **Knob** - Used to continuously vary certain parameters. The knob has an acceleration factor that causes the rate of change to increase as the knob is turned faster. Turning slowly allows for a fine adjustment at the smallest displayed decimal place.

2.4 General Operation

2.4.1 Display Elements

The Model 3150 uses a character display to depict information about the current state of the system. The display can be broken down into four basic elements: static fields, non-editable data fields, editable data fields, and soft key labels (see Figure 2).

2.4.1.1 Static Fields

Static fields are elements on the display which do not change from moment to moment. These can include screen titles and error messages.

2.4.1.2 Non-Editable Data Fields

Non-editable data fields are used mainly to display read back information, such as temperature, TEC current, etc. These fields can have a prefix or suffix label, such as “T=” or “I=”, and are periodically updated by the system.

2.4.1.3 Editable Data Fields

Editable data fields are used for TEC and system settings such as I_{TE} set point, temperature set point, display contrast, etc. An editable field has three distinct display states: focused, non-focused, and read-only.

The focused state indicates that the field has the input “focus.” When a field has the focus, a right pointing arrow (\rightarrow) is placed to the left of the field. Any keyboard entry or knob adjustment will be applied to the field, and only one field at a time on the display can have focus. Move between fields using the up and down arrow keys.

The non-focused state indicates that the field is editable, but does not currently have the focus. These fields are indicated with a right pointing triangle (\blacktriangleright) to the left of the field. Using the up and down arrows, focus can be moved to these fields.

When the editable data field is in the read-only state, it looks and acts exactly like a non-editable data field. Like the non-editable data field, it cannot have focus, and the up or down arrow keys will skip over the field. This state is used primarily to lockout specific data elements from front panel change when the Model 3150 is in remote mode. Any IEEE-488 or RS-232 communication will place the unit in remote mode, and editable fields that are protected during remote operations change to the read only state.

2.4.1.3.1 Changing Data Fields

A data field can only be changed from the front panel when the field is the focus. Some fields are numeric-based, such as current set point or temperature limits. Other fields are multi-choice fields, such as Yes/No fields. Both types are changed with the left and right arrows or the knob.

2.4.1.4 Soft Keys

Soft key labels are labels for the two gray buttons located to the immediate right of the display. Each label either indicates the action that is performed when the corresponding key is pressed (such as changing screens), or the state of a data element in the system (such as on/off toggle switch). In the first case, pressing the corresponding soft key will cause the action to happen, such as changing to the setup screen when the **Setup** soft key is pressed from a TEC's main screen. In the second case, pressing the soft key will change the state of the associated data value.

Like the editable data fields above, certain soft keys are programmed to enter a "display-only" mode when the unit enters remote mode. Display-only soft keys are displayed in lower case, and will not function until the unit returns to local mode.

On some screens, such as the configure menu (see Figure 6), there are more than two soft key selections. In this case, the active soft keys have a left pointing arrow (←) to the right of the soft key label. Pressing the **SHIFT** key will toggle between the outer and inner two soft keys.

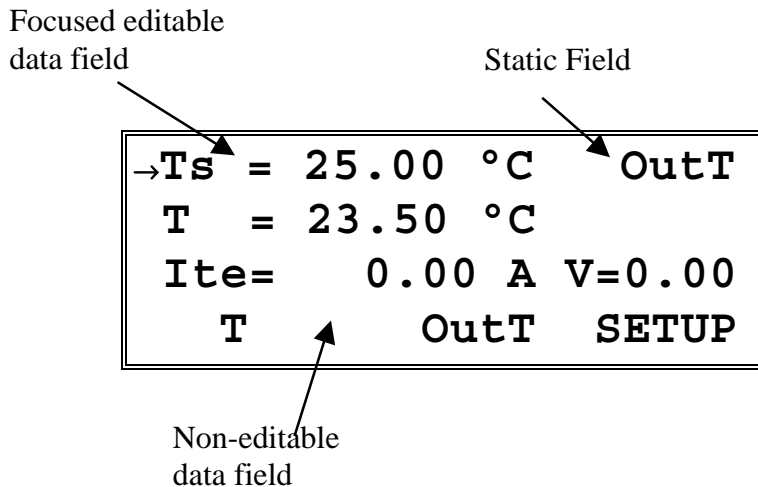

Figure 2 - A Sample Screen with Various Data Fields

2.4.2 Function Keys

For macros and special functions, the **FUNC** key is used both to execute and to enter the setup screen on the particular function. For example, if the 3150 supported a special function assigned to the up arrow key, to enter the setup screen of this function, press *and hold* the **FUNC** key, then press the up arrow key, then release both. This would enter the setup screen for this function. To execute this function, press *and release* the **FUNC** key, then press and release the up arrow key. If functions are not setup/supported for a particular key, the 3150 will beep. The 3150

supports assignment of macros to the arrow keys, the **MASTER** key, the **MENU** key, and the **TEC** key.

2.4.3 Menu Structure

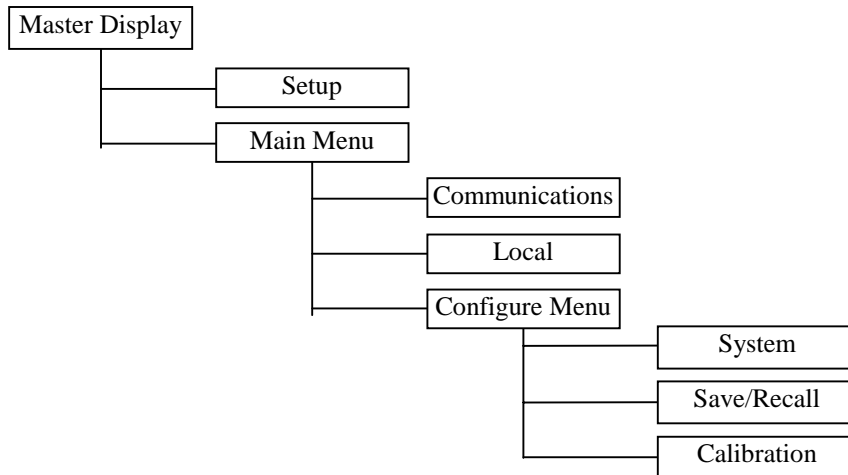

Figure 3 - Model 3150 Menu Structure

2.4.4 Master Display

The Master Display is shown in Figure 4. This is the highest level display and indicates the status of the temperature controller.

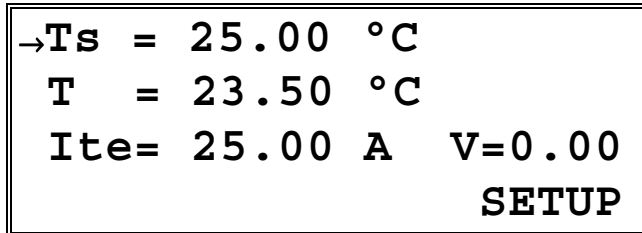

Figure 4 - Master Display

The Master Display can be accessed from any screen in the system by pressing **MASTER**.

2.4.5 Main Menu

The Main Menu is shown in Figure 5. This is the second highest menu and is used to access four general system functions:

1. **COMM**- Pressing the adjacent soft key gives access to the GPIB and RS232 parameters.
2. **LOCAL** - When the unit is in remote mode, either through GPIB or RS-232C communications, the **Local** soft key will be available. Pressing it returns the 3150 to a local state. When in local mode, this key does *not* appear on the display. The 3150 is placed in remote mode through GPIB or RS232 communication, or during the execution of a macro or special function.
3. **CONFIG** - Pressing the adjacent soft key gives access to the general configuration menu, with soft keys to access system configure, save/recall, and calibration screens.

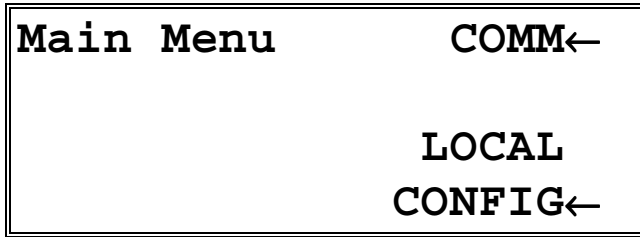

Figure 5 - Main Menu

2.4.6 Configure Menu

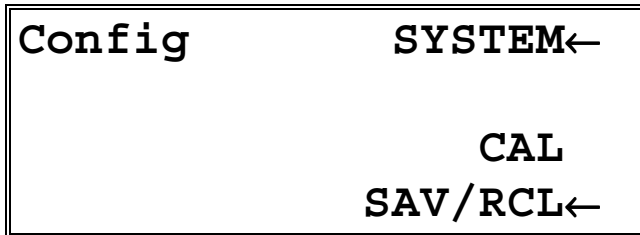
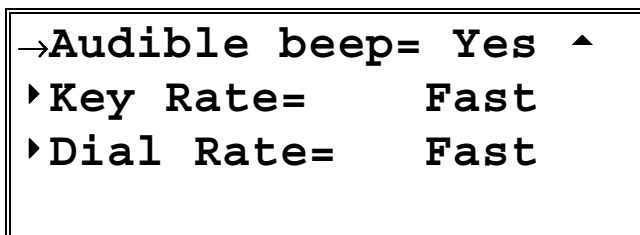
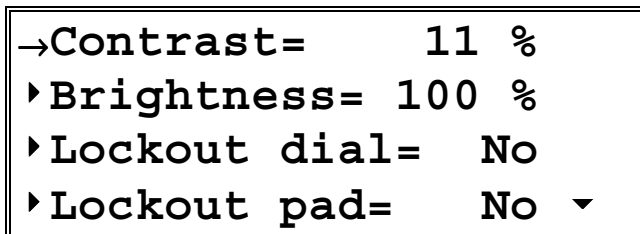

Figure 6 - Configure Menu

The configure menu provides access to the system configuration, calibration, and save and recall screens.

2.4.7 System Configure Screen



The system configure screen controls basic operation of the 3150 system. **Brightness** varies the backlighting intensity. **Contrast** is used to optimize the viewing angle.

Lockout dial disables the dial to avoid accidental changes in active data fields if the dial is bumped.

Lockout pad locks out the left and right arrow keys, the data entry portion on the keypad. Navigation keys, such as up and down, **MENU**, **MASTER**, and **FUNC** continue to work.

Note that both the Lockout dial and Lockout pad settings are temporarily suspended while in the Configure System Screen, allowing the dial and keypad lockout settings to be changed while in this screen..

Audible Beep controls the system's audible beeper. The beeper indicates errors, invalid data entry, and other situations where the 3150 needs to alert the user.

Key Rate - this controls the speed at which, when a key is held down, it repeats. Settings are **Slow**, **Medium**, and **Fast**.

Dial Rate - like the **Key Rate** setting, this controls the acceleration of the dial as it is turned. Settings are **Slow**, **Medium**, and **Fast**.

2.4.8 Save/Recall Screen

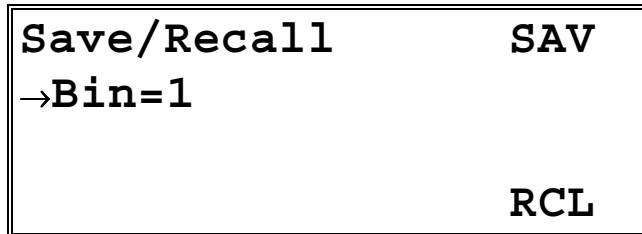

Figure 7 - Save/Recall Screen

The Save and Recall functions are used to store and retrieve 3150 setup configurations for future use. For example, a specific test setup may be saved for later use, and then another setup may be used presently. Then, when the user desires to perform the specific test, its setup is simply recalled.

Non-volatile memory is used for saving the instrument parameters. When a save operation is performed, all of the parameters which are currently in effect on the 3150 are stored. The user selects a “bin” number for saving the parameters, up to the maximum available in the instrument. Then, when that “bin” number is recalled, the 3150 is restarted and the parameters are reconfigured to the previously stored values. A special “bin 0” is reserved for the reset state. Recalling bin 0 will reset the unit to factory defaults.

2.4.9 Calibration Screen

Pressing the **Cal** soft key displays the TEC calibration screen. See section 7.2 for TEC calibration.

2.4.10 Configure Communications Screen

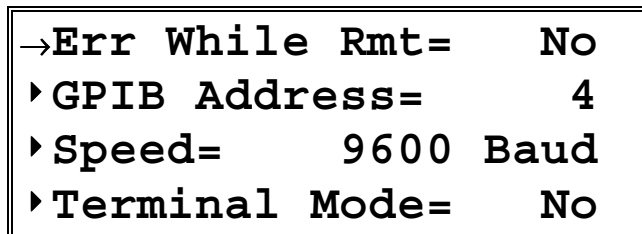

Figure 8 - Communications Screen

The **GPIB Address** is the IEEE-488 device address assigned to the 3150. Valid addresses are 1 to 31. See the *Computer Interfacing Manual* for a description of the **Terminal Mode** and **Speed**.

2.4.10.1 Error Message Control

Error messages may appear on the display when error conditions occur which force the output off or reflect hardware errors in the 3150. Chapter 9 contains an explanation of the error message which may be reported by the 3150. Display of error messages on the 3150 screen may be disabled while in remote mode by setting **Err While Rmt** to **No**, or by using the GPIB command **REMERR** to set this value remotely. Errors will continue to accumulate in the error queue, but will not be displayed on-screen.

Each press of the **MASTER** button will clear one error.

2.5 Rear Panel Familiarization

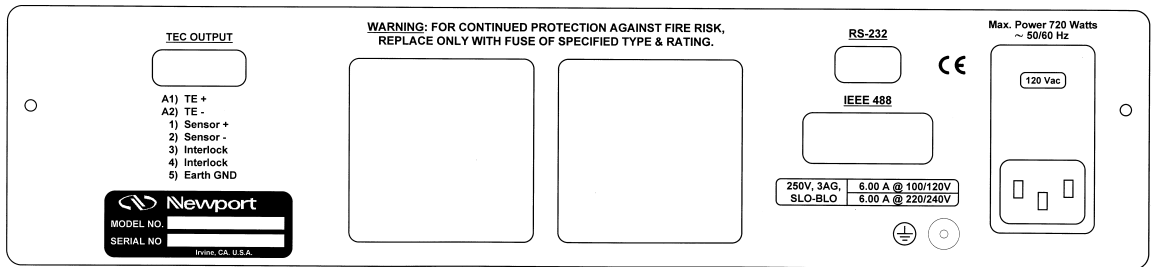

Figure 9 - Rear Panel

2.5.1 GPIB Connector

The GPIB connector, located on the back panel, allows full remote control as described in the *Computer Interfacing Manual*. It accepts a standard IEEE-488 cable for remote control, and uses Metric lock screws.

2.5.2 RS-232 Connector

The 3150 has an RS-232 connector located on the back panel. See the *Computer Interfacing Manual* for a more complete description of the RS-232 interface.

2.5.3 Input Power Connector

Accepts a standard line cord for AC input. Also selects one of four AC input settings: 100V, 120V, 220V, and 240V. The cord must be removed to change the setting. A small screwdriver will open the top of the module and expose the rotary switch. Select the range that is closest to your expected nominal RMS line voltage. The voltage selection is set for 120 VAC prior to shipping. A caution sticker is then placed over the input power connector to help insure the customer checks for proper voltage.

CAUTION

Do not exceed 250 VAC on the line input.

Do not operate with a line voltage that is not within $\pm 10\%$ of the line setting. Too low of an input voltage may cause excessive ripple on the DC supplies. Too high of an input voltage will cause excessive heating.

2.5.4**Ground Post** 

Provides access to chassis ground, which is also an earth ground as long as a standard 3-wire line cord is used. This is a protective conductor terminal to be used to achieve chassis grounding requirements when the main connectors don't provide an earth ground terminal. Use a minimum of 18 gauge wire to connect to this terminal.

2.6**Warm Up and Environmental Consideration**

Operate the 3150 at an ambient temperature in the range of 0 to +40°C. Storage temperatures should be in the range of -20 to +60°C. To achieve rated accuracy, let the 3150 warm up for 1 hour. For greatest accuracy, recalibrate when ambient temperature changes more than a few degrees.

CAUTION

Operating above +40°C can cause excessive heating and possible component failures.

3 Temperature Controller Operation

3.1 General Features

The 3150 Temperature Controller is a precision thermoelectric cooler controller. Features include:

- Closed-case calibration
- Operational with most thermistors, IC and RTD temperature sensors
- Flexible setup with Save/Recall front panel functions
- High temperature stability
- Current Limit

3.2 TEC Safety Features

3.2.1 Conditions Which Will Automatically Shut Off the TEC Output

- High Temperature Limit
- Low Temperature Limit
- R Limit
- TEC Open
- Sensor Open
- Sensor Select changed
- Sensor Shorted
- Mode Change

Clearing the appropriate bits in the TEC OUTOFF register can disable each of these conditions. See the *Computer Interfacing Manual* for additional information.

3.3 The TEC Connectors

A high power 7W2 female D-connector is used for input and output connections, as shown by the pin out diagram below.

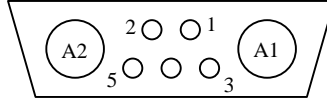

Pin	Description	3150-02 Cable Color Code
A1	TE+	Red
A2	TE-	Black
1	Sensor+	Green
2	Sensor-	White
3	Interlock	
4	Interlock	
5	Ground	

Table 1 - TEC Connector Pinout

3.3.1 TEC Interlock

On the TEC input/output connector pins 3 and 4 form the interlock path. The TEC interlock functions in a normally open condition, where the output will be shutdown only when pins 3 and 4 are shorted together.

3.3.2 TEC Grounding Consideration

The TEC output is isolated from chassis ground, allowing either output terminal to be grounded at the user's option.

3.4 TEC Operation

3.4.1 TEC Main Screen

The TEC main screen is shown Figure 10 and described below.

```

→Ts= 25.00 °C
  T=  25.00 °C
  Ite= 0.00 A
I V T R C InT SETUP←

```

Figure 10 - TEC Main Screen

Is=, Ts=, Rs=, is=, vs= - Indicates the set point value of current, temperature, resistance, AD590 sensor current, or LM335 sensor voltage, respectively. In the screen shown above, the **Ts** is shown. **Is, Rs, is,** and **vs** would be seen when operating in those modes.

I=, T=, R=, i=, v= - Indicates the measured value of current, temperature, resistance, AD590 sensor current, or LM335 sensor voltage, respectively. An **err** indicates a sensor error, usually caused by the sensor not hooked up or the wrong sensor selected. In the screen shown above, the **T** is shown. **I, R, i,** and **v** would be seen when operating in those modes.

SETUP - Pushing the adjacent soft key activates the setup screen.

The bottom line on the display has 6 “LED” elements, each indicating a particular state of the TEC. They are defined as:

I	When illuminated, indicates the TEC module is in current limit.
V	When illuminated, indicates the TEC module has reached it's voltage limit.
T	When illuminated, indicates the TEC module is outside the temperature limits defined by THI and TLO in the setup screen.
R	When illuminated, indicates the TEC module is outside the reference limits defined by RHI/vHI/iHI and RLO/vLO/iLO in the setup screen.
C/H	When illuminated, indicates that the TEC is cooling or heating.
OutT/InT	When illuminated, indicates that the TEC is out of tolerance or in tolerance as defined by Tol Time and Tol Temp in the setup screen.

3.4.2 TEC Setup Screen

The TEC Setup screen is shown in Figure 11. Each section is described below in detail.

```

→Sens=          RTD  ▲
▸Mode=          Const T
▸Gain=          30
▸Lim Ite=       2.0 A ▼

```

```

→Tol Time= 5.000 S  ▲
▸Tol Temp= 0.20 °C
▸Lim Tl= 10.00 °C
▸Lim Th= 50.00 °C ▼

```

```

Vpow=          10.00 V  ▲
Ths=           24.9 °C
Tamb=          23.4 °C

```

```

→C1= 3.9080 x 10-3  ▲
▸C2=-0.5802 x 10-6
▸C3=-4.272 x 10-12
▸R0=           100.00 Ω

```

Figure 11 - TEC Setup Screens

3.4.2.1 The ▲ and ▼ Soft Keys

Pushing the ▲ (previous) soft key returns to the previous screen, while pressing the ▼ (next) soft key advances to the next screen.

3.4.2.2 Sensor (Sens)

Selects the temperature sensor type used in your TEC mount. If the **None** is selected, only the ITE mode is allowed. This type is intended for applications running without a temperature sensor. See the following sections for discussions of the various sensor

types. The TEC supports the thermistor sensors (10 μ A and 100 μ A range), AD590, LM335, and RTD sensors.

3.4.2.3 Mode

3.4.2.3.1 Constant Temperature Mode (Const T)

This mode holds the TEC at a constant temperature based on feedback from the sensor in the TEC mount, using “Ts=” and “T=” variables. In this mode, the 3150 uses a control loop comparing the sensor input to the temperature set point, driving the ITE current positive or negative to reach and maintain that set point. The sensor’s input is converted to temperature for display of actual TEC temperature. The ITE current is also displayed in this mode.

3.4.2.3.2 Constant Resistance/Reference Mode (Const R)

This mode operates identically to the Const T mode, but the sensor input is not converted to temperature, and is displayed in unconverted form. Likewise, the set point is used directly, not converted from temperature. Thermistor and RTD sensors use resistance (“Rs=” and “R=” variables), LM335 sensors use millivolts (“vs=” and “v=” variables), and AD590 sensors use microamps (“is=” and “i=” variables). Const R is primarily intended for users who know a sensor set point in “sensor” units, not in °C. ITE current is also displayed in these modes.

3.4.2.3.3 Constant Current Mode (Const Ite)

Unlike the modes above, the Const ITE mode allows the operator to explicitly set the amount and direction of current flow through the TEC, using “Is=” and “Ite=” variables. If a sensor has been selected, the TEC temperature will be displayed. Although temperature is not a factor in the amount or direction of current flow, the high and low temperature limits are observed, and will shutdown the output if exceeded in Const ITE mode, if a sensor is selected. For no temperature limits, set the sensor type to “None.” Use caution when limits are not active, as the temperature may exceed your TEC’s thermal limits.

3.4.2.3.4 Effects of Calibration on TEC modes

On startup, the TEC performs an auto-calibration to eliminate most of the error in ADC and DAC values. After this auto-calibration, each sensor type supported by the TEC has an offset calibration, while the ITE set point and read back has a two point calibration. These calibration constants are then used to calibrate a set point or read back value. This includes “cross-mode” values, such as displaying actual current while in constant temperature mode. While the current *set point* calibration has no effect in Const T mode, the *read back* calibration is used to more accurately display the actual current.

3.4.2.4 Gain

The Gain function controls two parameters of the hybrid PI control loop; proportional gain and integration time.

When the actual temperature and the set point are different, an error voltage is generated. This error voltage is directly related to the difference in the actual and set point temperatures. The error voltage is then amplified by the proportional gain. This amplified error voltage controls the amount of current driven through the TEC. The higher the gain, the more current will be driven for any given temperature difference, with the maximum current being determined by the current limit.

The error voltage also drives an integrator. The integrator's output also controls the amount of current being driven through the TEC. The integrator is an amplifier whose gain is proportional to time. The longer a given error voltage is present, the more current will be driven through the TEC, with the maximum current being determined by the current limit. The speed at which the integrator's output increases is the integration time, which can be "Slow" or "Fast".

The allowed Gain values are: 0.2 Slow, 0.6 Slow, 1 Slow, 1 Fast, 2 Slow, 3 Fast, 5 Fast, 6 Slow, 10 Slow, 10 Fast, 20 Slow, 30 Fast, 50 Fast, 60 Slow, 100 Fast or 300 Fast. The number actually defines the proportional loop gain. The slow/fast suffix indicates the speed at which the integrator's output increases. The slow setting allows for larger masses or greater distance between the sensor and the thermoelectric cooler by slowing the speed of the integrator.

Both the proportional gain and the integration time must be matched to the thermal characteristics of the TE cooler and sensor. If the settings are incorrect, the temperature set point will take an excessive amount of time to settle, or it will oscillate around the set point and never settle.

The Gain setting depends on the type of TE cooler that you are using, but we can suggest guidelines for selecting the proper gain. Set the gain to 1 fast and increase it until the actual temperature oscillates around the set temperature. Then reduce the gain to the next lower value, without changing the suffix.

To read the Gain setting, go to the setup. The display will show the value of the Gain setting. In Constant I_{TE} mode the Gain setting has no effect.

3.4.2.5 Limits

3.4.2.5.1 TE Current Limit (Lim Ite)

This sets the maximum drive current the TEC will allow. This maximum applies to all modes (constant $I_{TE}/R/T$).

3.4.2.5.2 Temperature Limits (Lim Th and Lim TI)

The TEC supports both a low and high temperature limit, and can be programmed to turn the TEC output off in the event those limits are exceeded (default state). The temperature limits are monitored regardless of the mode of the TEC. This has the added safety feature of shutting down the TEC in Const ITE or Const R mode when the temperature limit is exceeded (see TEC:OUTOFF command in *Computer Interfacing Manual* for additional details).

Caution: these limits do not apply if the sensor type is set to “None.”

3.4.2.5.3 Resistance/Reference Limits (Lim Rh/vh/ih and Lim RI/vlo/il)

Like the temperature limits, the TEC also supports both a low and high resistance/reference limit, and can be programmed to turn the TEC output off in the event those limits are exceeded, although by default this is disabled. These limits are monitored only while in Const R/v/i mode.

3.4.2.6 Tolerances (Tol Time and Tol Temp)

The **Tol Time** and **Tol Temp** elements are used for determining when the TEC is “in tolerance,” where the actual temperature has stayed within **Tol Temp** of the set point for at least **Tol Time** seconds. The **Tol Time** value is expressed in seconds, and can range from 0.001 seconds to 50 seconds. The **Tol Temp** value is displayed in °C (the most common usage), and can range from 0.01 to 10.00. If at any time it goes outside the tolerance range, the time restarts at zero.

As an example, if the **Tol Time** is set to 5 seconds, the **Tol Temp** is set to 0.2°C, and the temperature set point was 25.0°C, the TEC would have to stay within 24.8°C and 25.2°C to be within tolerance. Out of tolerance is indicated by a **OutT** status field on the bottom of the TEC Main Screen.

3.4.2.7 Vpow, Ths, and Tamb

The three values monitor the operation of the TE drive section. **Vpow** is the supply voltage, and can range from approximately 10V to 32V, depending on the TE load. **Ths** is the heatsink temperature, and will shutdown the unit if it exceeds 85°C. **Tamb** is the internal ambient temperature of the unit.

3.4.2.8 C1, C2, C3, and Ro

See the section of each of the sensors for a description of how C1, C2, C3, and Ro are used.

3.4.3 Thermistor and Thermistor Current Selection

3.4.3.1 Introduction

Choosing the right sensing current depends on the range of temperature you want to measure and the resolution you require at the highest measured temperature. To correctly set the thermistor current you must understand how the thermistor and the 3150 interact.

3.4.3.2 Thermistor Range

Thermistors can span a wide temperature range, but their practical range is limited by their non-linear resistance properties. As the sensed temperature increases, the resistance of the thermistor decreases significantly and the thermistor resistance changes less for an equivalent temperature change. Consider the temperature and sensitivity figures below.

<u>Temperature</u>	<u>Sensitivity</u>
-20°C	5600 ohms/°C
25°C	439 ohms/°C
50°C	137 ohms/°C

In the 3150 the practical upper temperature limit is the temperature at which the thermistor becomes insensitive to temperature changes. The maximum ADC input voltage of the 3150 limits the lower end of the temperature range. Thermistor resistance and voltage are related through Ohm's Law ($V = I \times R$). The 3150 supplies current to the thermistor, either 10 μA or 100 μA , and as the resistance changes a changing voltage signal is available to the thermistor inputs of the 3150. The 3150 will over-range when the input voltage exceeds about 5 Volts. Figure 12 graphically shows the lower temperature and upper voltage limits for a typical 10 k Ohm thermistor. The practical temperature ranges for a typical 10 K thermistor (a 10 K thermistor has a resistance of 10 k Ohms at 25°C) are given in the table below.

<u>Sensing Current</u>	<u>Temperature Range</u>
10 μA	-51 to 40°C
100 μA	-10 to 100°C

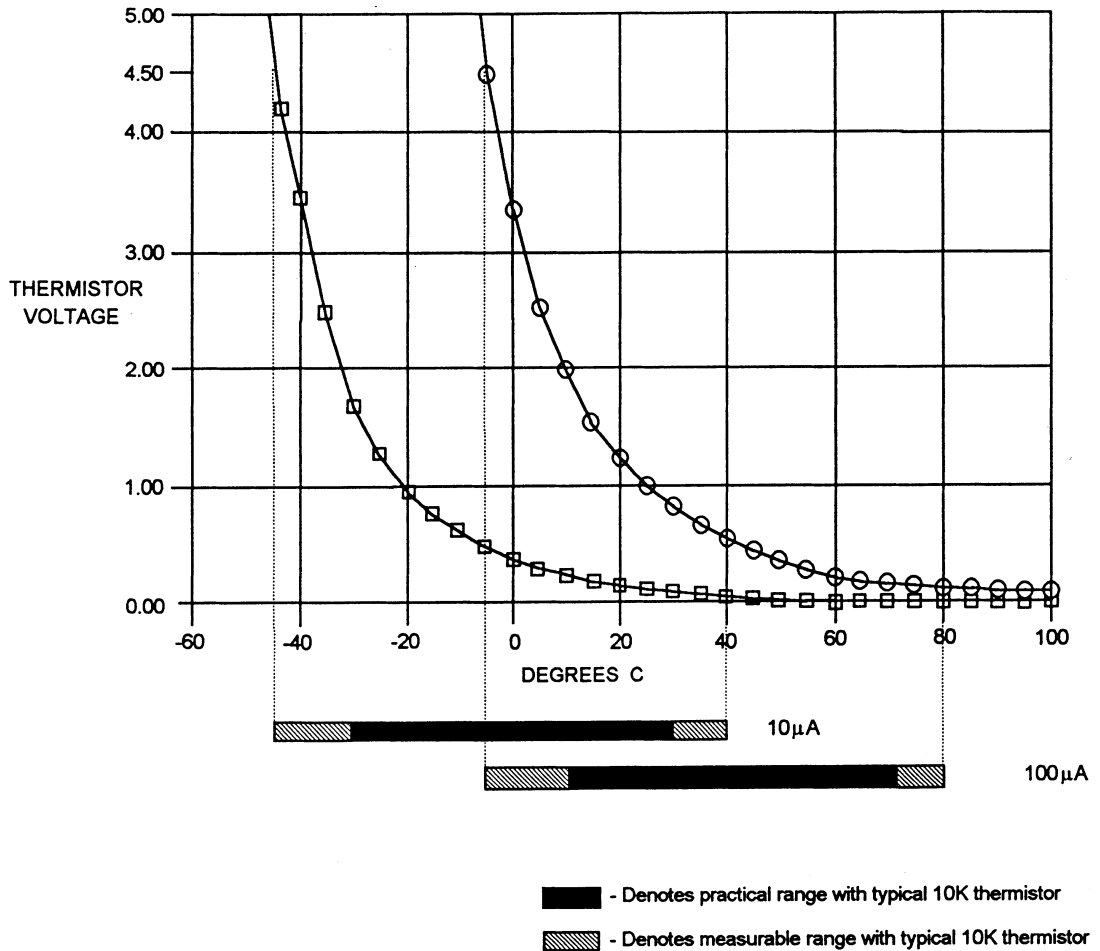

Figure 12 - Thermistor Temperature Range

3.4.3.3 Temperature Resolution

You must also consider measurement resolution since the resolution decreases as the thermistor temperature increases. The 3150 uses an A/D converter that has a maximum resolution of about 0.763Ω in $10\mu\text{A}$ range. The microprocessor converts this digital number to resistance, stores this resistance, then converts it to a temperature using the Steinhart-Hart equation, and stores this temperature. A temperature change of one degree centigrade will be represented by a greater resistance increase (and therefore more ADC counts) at lower temperatures because of the non-linear resistance of the thermistor. Resolution figures for a typical $10\text{ k}\Omega$ thermistor are given below.

<u>Temperature</u>	<u>Voltage at 10 μA</u>	<u>Resolution</u>
-20 °C	56.0 mV/°C	0.018 °C/mV
25 °C	4.4 mV/°C	0.230 °C/mV
50 °C	1.4 mV/°C	0.700 °C/mV

For this thermistor, a temperature change from -20°C to -19°C will be represented by 737 ADC counts (if supplied with 10 μ A). The same thermistor will only change about 18 ADC counts from 49°C to 50°C.

3.4.3.4 Selecting Thermistor Current

To select the current setting for a typical 10 K Ω thermistor, determine the lowest temperature you will need to sample and select the current according to the range limits given above. If the temperature you want to sample is below -10°C you should use the 10 μ A setting.

With the current set to 10 μ A the best resolution you will see will be a 1.0°C temperature change. If, for example, the lower limit is 0°C you can choose either setting, but there is a tradeoff in terms of resolution. If you need better than 0.1°C measurement resolution you will have to change to 100 μ A.

If you need high resolution over a narrow range, for a very accurate measurement, you can set the current setting for the maximum resolution. For example, at a high temperature of 15°C, you require a measurement resolution of at least 0.05°C. This resolution is within the range of either setting, but at the 10 μ A setting the resolution is only 0.2°C while at the 100 μ A setting the resolution is better than .05 °C.

Generally, it is best to use the 100 μ A setting for all measurements of -10°C or greater with a 10 K thermistor.

3.4.3.5 Selecting Thermistors

The type of thermistor you choose will depend primarily on the operating temperature range. These guidelines for selecting the range and resolution will apply to any thermistor. 10 K thermistors are generally a good choice for most laser diode applications where high stability is required near room temperatures. Similarly, 10 K thermistors are often a good choice for cooling applications where you want to operate at temperatures from -40°C to room temperature.

If you require a different temperature range or the accuracy you need can't be achieved with either current setting, select another thermistor. Thermistor temperature curves, supplied by the manufacturer, show the resistance versus temperature range for many other thermistors. Contact a Newport application engineer with your specific application.

3.4.3.6 The Steinhart-Hart Equation

The Steinhart-Hart equation is used to derive temperature from the non-linear resistance of an NTC (Negative Temperature Coefficient) thermistor.

The following section contains an explanation of the Steinhart-Hart equation and the values of these constants for some common thermistors.

Two terminal thermistors have a non-linear relationship between temperature and resistance. The resistance versus temperature characteristics for a family of similar thermistors is shown in Figure 13. It has been found empirically that the resistance versus temperature relationship for most common negative temperature coefficient (NTC) thermistors can be accurately modeled by a polynomial expansion relating the logarithm of resistance to inverse temperature. The Steinhart-Hart equation is one such expression and is given as follows:

$$1/T = C1 + C2 (\text{Ln } R) + C3 (\text{Ln } R)^3 \quad (\text{Eq. 1})$$

Where T is in KELVIN. To convert T to °C, subtract 273.15.

Once the three constants C1, C2, and C3 are accurately determined, only small errors in the calculation of temperature over wide temperature ranges exist. Table 2 shows the results of using the equation to fit the resistance versus temperature characteristic of a common 10 kΩ thermistor. The equation will produce temperature calculation errors of less than 0.01°C over the range -20 °C to 50 °C.

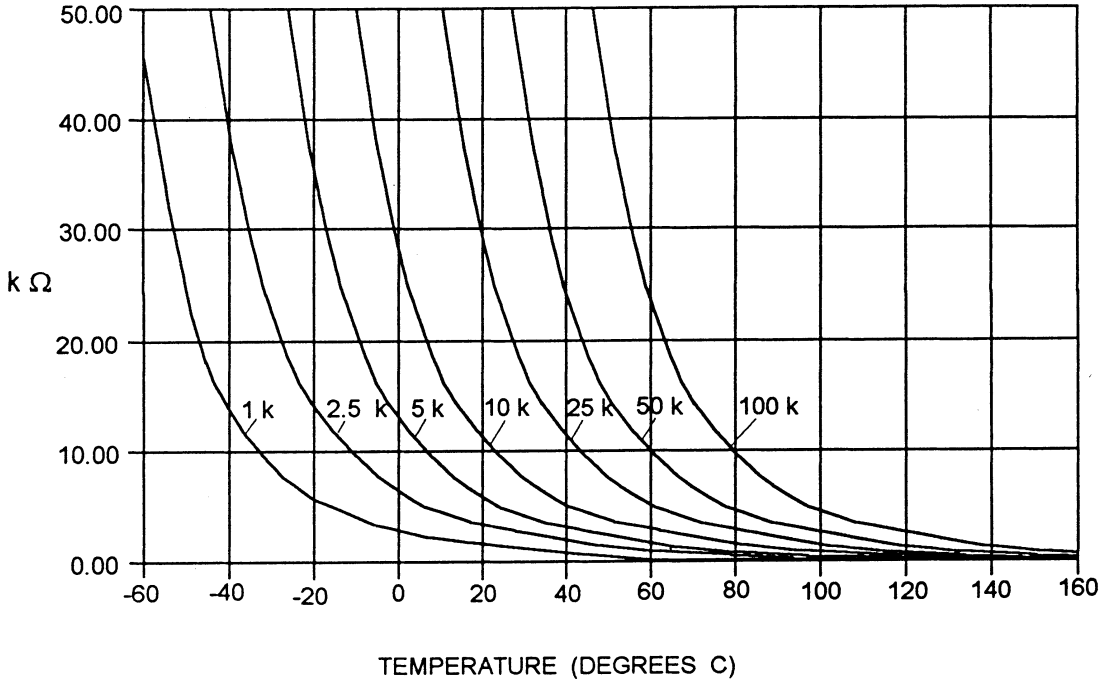

Figure 13 - Thermistor Resistance versus Temperature

R^1	-----Error T (°C)----- T Actual	Third Order Fit. Eq. 1 ²
96974	-20.00	-0.00
55298	-10.00	0.00
32651	0.00	-0.00
19904	10.00	-0.00
12494	20.00	-0.00
10000	25.00	0.00
8056	30.00	0.00
5325	40.00	0.00
3601	50.00	-0.00

Table 2 - Comparison of Curve Fitting Equations

The constants C1, C2, and C3 are expressed in the form n.nnnn, simplifying entry into the 3150.

¹ Resistance of a BetaTHERM 10K3 thermistor.

² Constants C1 = 1.1292×10^{-3} , C2 = 2.3411×10^{-4} , C3 = 0.8775×10^{-7}

3.4.3.7 Table of Constants

We have listed some common thermistors and included the appropriate calibration constants for the temperature range -20 °C to 50 °C in Table 3. The Model 3150, by default, uses the BetaTHERM 10K3 thermistor values.

<i>Manufacturer</i>	<i>C1 * 10⁻³</i>	<i>C2 * 10⁻⁴</i>	<i>C2 * 10⁻⁷</i>
BetaTHERM 10K3	1.129241	2.341077	0.877547
BetaTHERM 0.1K1	1.942952	2.989769	3.504383
BetaTHERM 0.3K1	1.627660	2.933316	2.870016
BetaTHERM 1K2	1.373419	2.771785	1.999768
BetaTHERM 1K7	1.446659	2.682454	1.649916
BetaTHERM 2K3	1.498872	2.379047	1.066953
BetaTHERM 2.2K3	1.471388	2.376138	1.051058
BetaTHERM 3K3	1.405027	2.369386	1.012660
BetaTHERM 5K3	1.287450	2.357394	0.950520
BetaTHERM 10K3	1.129241	2.341077	0.877547
BetaTHERM 10K4	1.028444	2.392435	1.562216
BetaTHERM 30K5	0.933175	2.213978	1.263817
BetaTHERM 30K6	1.068981	2.120700	0.901954
BetaTHERM 50K6	0.965715	2.106840	0.858548
BetaTHERM 100K6	0.827111	2.088020	0.805620

Table 3 - Thermistor Constants

3.4.4 AD590 and LM335

3.4.4.1 General

The 3150 uses two constants (C1 and C2) for calibrating the two linear thermal sensing devices, the AD590 and the LM335. C1 is used as the zero offset value, and C2 is used as the slope or gain adjustment. Therefore, C1 has a nominal value of 0, and C2 has a nominal value of 1 when using the AD590 or LM335. In order to calibrate a linear sensor device, the sensor must be operated at an accurately known, stable temperature. For example, the sensor may be calibrated at 0 °C if the sensor is placed in ice water until its temperature is stable. A highly accurate temperature probe, thermometer, environmental chamber, etc., may also be used to determine the known temperature for calibration.

3.4.4.2 AD590 Sensor

The AD590 is a linear thermal sensor that acts as a current source. It produces a current, i , which is directly proportional to absolute temperature, over its useful range (-50 °C to + 150 °C). This nominal value can be expressed as:

$$i = 1 \mu\text{A} / \text{K}$$

where i is the nominal current produced by the AD590, and K is in Kelvin.

The 3150 uses i to determine the nominal temperature, T_n , by the formula:

$$T_n = (i / (1 \mu\text{A} / \text{K})) - 273.15$$

where T_n is in °C.

The displayed temperature, $T_d = C1 + (C2 * T_n)$, is then computed, where $C1$ and $C2$ are the constants stored in the 3150 for the AD590. The AD590 grades of tolerance vary, but typically without adjusting $C1$ and $C2$, the temperature accuracy is $\pm 1^\circ\text{C}$ over its rated operating range. However, the AD590 is not perfectly linear, and even with $C1$ accurately known there is a non-linear absolute temperature error associated with the device. This non-linearity is shown in Figure 14, reprinted from Analog Devices specifications, where the error associated with $C1$ is assumed to be zero.

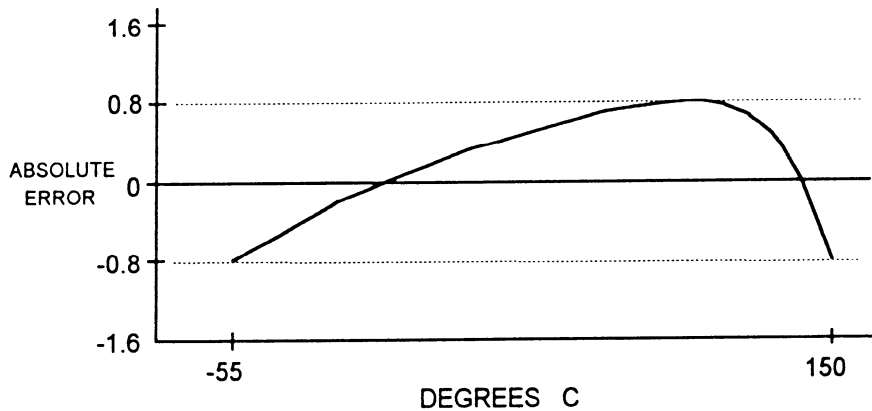

Figure 14 - AD590 Nonlinearity

If a maximum absolute error of 0.8°C is tolerable, the one point calibration of $C1$ should be used. If a greater accuracy is desired, the two point method of determining $C1$ and $C2$ should be used. Note however, the absolute error curve is non-linear, therefore the constant $C2$ will vary for different measurement points.

3.4.4.3

LM335 Sensor

The LM335 is a linear thermal sensor that acts as a voltage source. It produces a voltage, v , which is directly proportional to absolute temperature, over its useful range (-40°C to $+100^\circ\text{C}$). This nominal value can be expressed as:

$$v = 10\text{mV} / \text{K}$$

where v is the voltage produced by the LM335 and K is Kelvin.

The 3150 uses v to determine the nominal temperature, T_n , by the formula:

$$T_n = (v / (10\text{mV} / \text{K})) - 273.15$$

where T_n is in °C.

The temperature, T_d , which is displayed by the 3150 is calculated as follows:

$$T_d = C1 + (C2 * T_n)$$

where C1 and C2 are the constants stored in the 3150 for the LM335.

When the LM335 is calibrated to 25°C, C1 = 0 and C2 = 1, and the temperature accuracy is typically $\pm 0.5^\circ\text{C}$ over the rated operating range. However, the LM335 is not perfectly linear, and even with C1 accurately known there is a non-linear absolute temperature error associated with the device. This non-linearity caused error is typically $\pm 0.3^\circ\text{C}$, with the error associated with C1 assumed to be zero.

If a maximum absolute error of $\pm 0.3^\circ\text{C}$ can be tolerated, the one point calibration of C1 should be used. If a greater accuracy is desired, the two point method of determining C1 and C2 should be used. Note however, the absolute error associated with the constant C2 may vary over different temperature ranges.

3.4.4.4 Determining C1 and C2 for the AD590 and LM335

The nominal values of C1 and C2 are 0 and 1, respectively, for both types of devices. These values should be used initially for determining C1 and C2 in the methods described below.

The One Point method is easiest, but it ignores the non-linearity of the device. It is most useful when a high degree of temperature accuracy is not required.

The Two Point method can achieve a high degree of accuracy over a narrower operating temperature range, but requires two accurate temperature measurements.

3.4.4.4.1 One Point Calibration Method

The calibration described in this section is independent of the calibration procedure described in sections 7.2.4 and 7.2.6. Those sections deal with the internal calibration of the TEC, while the following calibration procedure is for calibrating the external AD590 or LM335 sensor. For the most accurate possible results, both calibration procedures should be performed.

The accuracy of this procedure depends on the accuracy of the externally measured temperature. It is used to determine the zero offset of the device, and it assumes that the gain (slope) is known.

1. Allow the 3150 to warm up for at least one hour. Select the desired sensor type in the setup menu.

2. Set the C1 parameter to zero. Set the C2 parameter to 1.
3. Place the sensor at an accurately known and stable temperature, T_a . Connect the sensor to the 3150 for normal Constant temperature operation. Allow the 3150 to stabilize at the known temperature, T_a and read the displayed temperature, T_d .
4. Determine the new value of C1 from the formula:

$$C1 = T_a - T_d$$

and enter the new C1 value.

3.4.4.4.2 Two Point Calibration Method

The calibration described in this section is independent of the calibration procedure described in sections 7.2.4 and 7.2.6. Those sections deal with the internal calibration of the TEC, while the following calibration procedure is for calibrating the external AD590 or LM335 sensor. For the most accurate possible results, both calibration procedures should be performed.

The accuracy of this procedure depends on the accuracy of the externally measured temperature. It is used to determine the zero offset of the device and the gain (slope).

1. Allow the 3150 to warm up for at least one hour. Select the desired sensor type in the setup menu.
2. Set the C1 parameter to zero. Set the C2 parameter to 1.
3. Place the sensor at an accurately known and stable temperature, T_{a1} . Connect the sensor to the 3150 for normal Constant temperature operation. Allow the 3150 to stabilize at the known temperature, T_{a1} and read the displayed temperature, T_{d1} . Record these values.
4. Repeat Step 3 for another known temperature, T_{a2} , and the corresponding displayed temperature, T_{d2} . The two known temperatures should be at the bounds of the intended operating range. For best results, make the range between T_{a1} and T_{a2} as narrow as possible.
5. Determine the new value of C1 and C2 from the following calculations.

$$C2 = (T_{a1} - T_{a2}) / (T_{d1} - T_{d2}), \text{ and}$$

$$C1 = T_{a1} - (T_{d1} * C2)$$

6. Enter the new C1 and C2 values.

3.4.5 RTD Sensors

The following equation is used in temperature to resistance conversions:

$$R_T = R_0 [1 + C1 \times T - C2 \times T^2 - C3 \times (T-100) \times T^3] \quad \text{for } T < 0^\circ\text{C}$$

$$R_T = R_0 [1 + C1 \times T - C2 \times T^2] \quad \text{for } T \geq 0^\circ\text{C}$$

where: R_T is the resistance in Ω at temperature T .
 T is the temperature in $^\circ\text{C}$.

3.4.5.1 RTD Constants

The constants entered for an RTD depend on the type of curve it has. Table 4 shows three standard types.

Curve	TCR ($\Omega/\Omega/^\circ\text{C}$)	C1	C2	C3	R0
Laboratory	.003926	3.9848×10^{-3}	-0.58700×10^{-6}	4.0000×10^{-12}	100.00
US	.003910	3.9692×10^{-3}	-0.58495×10^{-6}	-4.2325×10^{-12}	100.00
European	.003850	3.9080×10^{-3}	-0.58019×10^{-6}	-4.2735×10^{-12}	100.00

Table 4 - RTD Constants

The R_0 constant also applies for RTD sensors. It is nominally 100.00 Ω , but can be varied from 95.00 Ω to 105.00 Ω .

4 Principles of Operation

4.1 Introduction

A functional block diagram of the 3150 is shown in Figure 15. In each of the following sections there are functional block diagrams for the various circuit boards of the 3150.

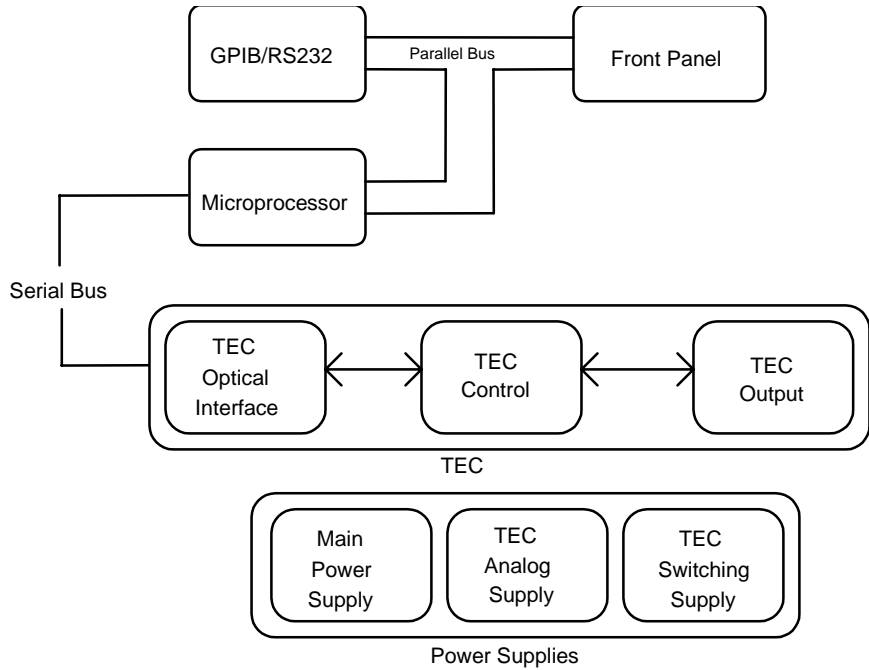

Figure 15 - 3150 Block Diagram

4.2 TEC Controller Theory of Operation

Figure 16 shows the functionality of the TEC. The following sections detail the theory of operation for each of the blocks in Figure 16.

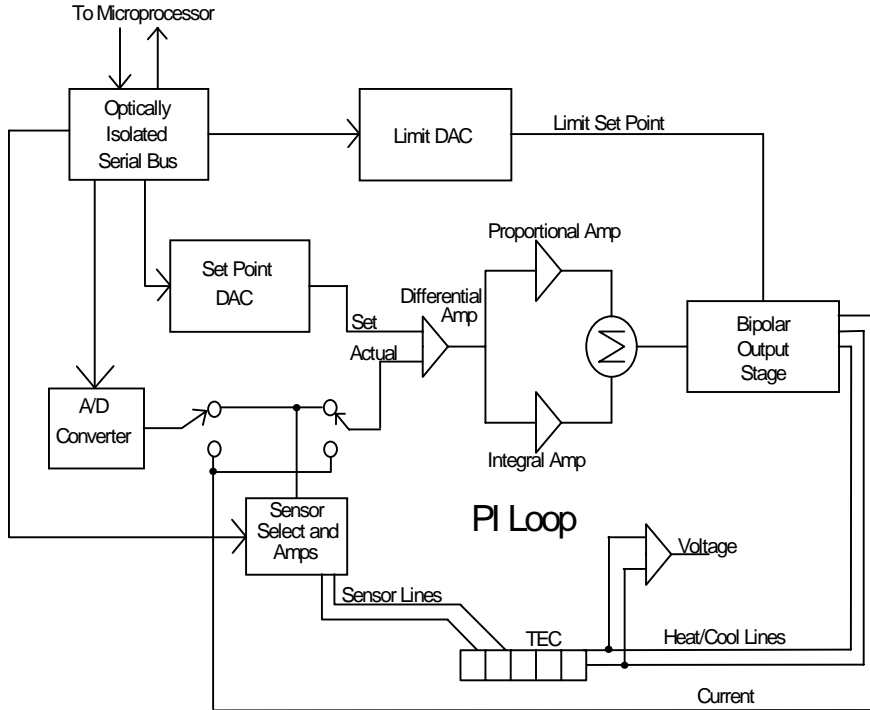

Figure 16 - TEC Board Diagram

4.2.1 TEC Interface

The TEC interface provides optically isolated serial communications between the TEC board and the microprocessor. Control signals are passed to the TEC board to set the TEC board status, current limit, and temperature set points. Instructions and data are sent over the serial interface to the optical barrier. Status and data are serially passed back to the microprocessor.

4.2.2 Limit DAC

The microprocessor loads the digitally stored current limit value into the current limit 12-bit DAC. The Limit DAC converts the digital limit signal from the microprocessor to a voltage which becomes the limit voltage for the Bipolar Output Stage. The current limit value is updated at power-up, at a "bin" recall, and whenever the LIM I_{TE} value is changed.

4.2.3 Set Point DAC

The microprocessor loads the digitally stored temperature or current set point value into the set point 16-bit DAC. The Set Point DAC converts a digital set point signal from the microprocessor to a voltage which becomes the set point input to the PI control loop. The TEC set point value is updated at power-up, at a "bin" recall, and whenever a TEC set point value is changed.

4.2.4 A/D Converter

The 16-bit A/D converter measures the sensor voltage, TE current, and TE voltage. The sensor measurement is used by the microprocessor in the calculation of temperature or thermistor resistance. The current measurement is used for the I_{TE} value and the voltage measurement is needed for V_{TE} .

4.2.5 Sensor Select

Sensor selection is accomplished in the Sensor Select block of the TEC board. Precision 100 μ A and 10 μ A current sources may be selected for thermistor control. RTD, LM335 and AD590 IC temperature sensors may also be selected. The AD590 has a +5 VDC bias voltage, the LM335 has a 1 mA bias current, and the RTD has a precision 1 mA current source.

The output of the Sensor Select block of the TEC board is a voltage which is proportional to the actual temperature. This voltage is fed to the A/D converter which provides a digital measurement to the microprocessor, and to the PI control loop to close the feedback loop when temperature is being controlled.

4.2.6 Difference Amplifier

A differential amp provides a difference signal to the PI control. This signal is the difference between set temperature and actual temperature voltage.

4.2.7 Proportional Amplifier

The Proportional amplifier is part of a digitally controlled gain stage consisting of the analog switches and their associated resistors. The analog switches vary the ratio of resistance in the feedback circuit to change the gain. The gain setting determines how fast the TEC reaches the set point temperature and how quickly it settles to this temperature.

4.2.8 Integrator

The signal from the difference amplifier is sent to an integrator which reduces the difference between the set point temperature and the actual temperature to zero, regardless of the gain setting. An analog switch discharges the integrating capacitor whenever integration is not required to prevent unnecessary difference signal integration.

4.2.9 Bipolar Output Stage

The Bipolar Output Stage consists of circuits which limit the TEC output, sense the TEC output polarity, sense voltage and current limit conditions, as well as supply the bipolar TEC output. The following sections discuss these functions of the Bipolar Output Stage.

4.2.9.1 Current Limiting

The output of the proportional amplifier and integrator together form the control signal. Output current limiting is effected by bounding the control signal so that it is always less than the limit current. The limit current is set with the front panel controls or through the GPIB. The bipolar current limit levels are established by the output of the current Limit DAC.

4.2.9.2 Current Limit Condition Sensing

Comparators sense the output to determine when output current limiting is occurring. When this condition occurs, the I Limit signal is sent to the microprocessor.

4.2.9.3 Voltage Controlled Current Source

The bounded output control signal is applied to an amplifier. This amplifier and the current sensing amplifier form the output voltage controlled current source. The output of this stage directly drives the externally connected TE cooler.

4.2.9.4 Voltage Limit Condition Sensing

Comparators sense the output to determine when the TEC output compliance voltage limiting is occurring. This condition occurs whenever the TEC output is open or connected to a high resistance. If this condition occurs, the V Limit error signal is passed to the microprocessor.

4.2.10 TEC Control Modes

The 3150 provides three control modes for operation, constant T (temperature), constant R (resistance, voltage, or current), and constant I_{TE} (current) modes. Each of these modes is discussed in the following sections.

4.2.10.1 T Mode

In constant T mode the TEC is driven to the set point temperature. This temperature is monitored by the sensor in the TEC. In the case of a thermistor sensor, the thermistor's resistance is used to determine TEC's temperature by using the Steinhart-Hart conversion equation. The resistance is determined by measuring the voltage across the thermistor (with a known current of $10\mu A$ or $100\mu A$). The I_{TE} current is also measured and saved. The TEC's output current is sensed across a resistor and the voltage is converted to an I_{TE} current value. V_{TE} is also measured.

When an LM335 sensor is used, a two-point conversion equation is used to determine the temperature. Its voltage is measured as well as the I_{TE} current and V_{TE} voltage.

When an AD590 sensor is used, another two-point conversion equation is used to determine the temperature. Its reference current is sensed across a resistor, and this voltage is measured. I_{TE} and V_{TE} are also measured.

4.2.10.2 R Mode

In constant R mode, the TEC is driven to the set point resistance, voltage, or current. This resistance, voltage, or current is measured. I_{TE} and V_{TE} are also measured.

4.2.10.3 I_{TE} Mode

In constant I_{TE} mode, the TEC is driven with a constant current, at the I_{TE} set point value. The I_{TE} current is sensed across a resistor and the voltage is converted to I_{TE} current.

4.3 Microprocessor Board

The Microprocessor Board contains the microprocessor, memory, the serial interface to the TEC, front panel interface, and circuitry that saves the state of the 3150 at power down. The block diagram of the Microprocessor Board is shown in Figure 17.

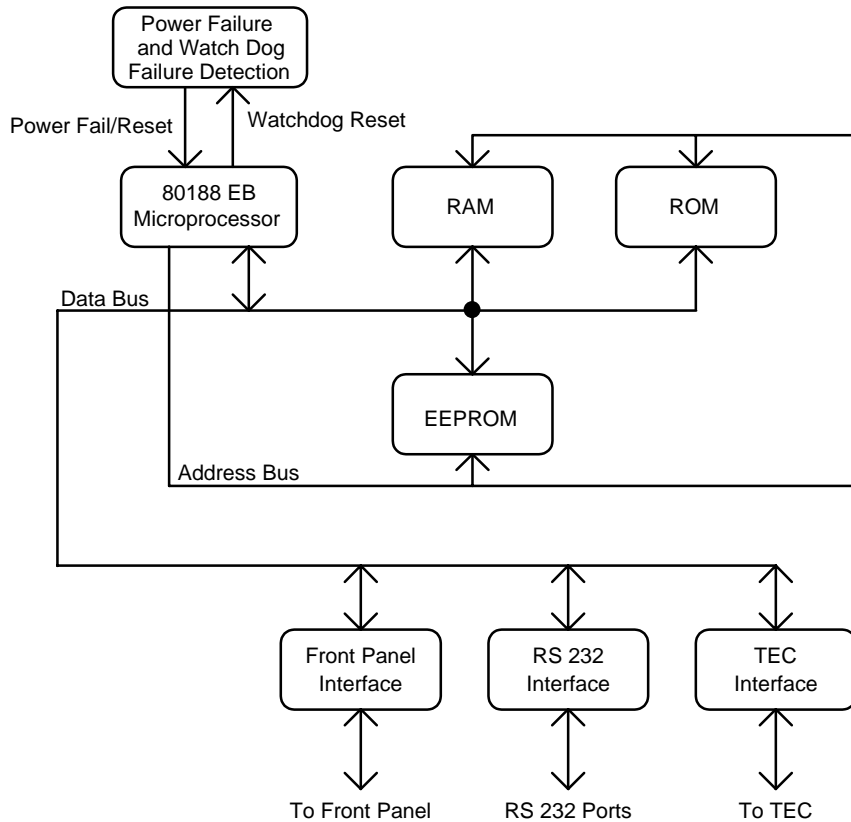

Figure 17 - Microprocessor Board Block Diagram

4.3.1 Microprocessor

The 3150 uses a CMOS 80188EB microprocessor to control its internal operations. The 3150 provides a fail-safe timer which generates a reset in the event of a malfunction. A 1 Hz watch-dog pulse is normally present. If for any reason this clock pulse fails to appear it will reset the 3150.

4.3.2 Memory

The 3150 uses three types of memory. RAM memory is retained only while power is applied to the unit. ROM memory contains the firmware. The third type of memory is electrically erasable programmable memory: EEPROM.

EEPROM stores calibration constants and other data which must be retained even when power is removed from the unit, and does not require battery backup. Examples of data stored in this memory include the TEC parameters and calibration constants.

4.3.3 Serial Interface

The 80188 communicates with the TEC controller via a serial bus. Parallel data from the microprocessor is converted to bi-directional serial data. Also provided is the RS-232 communication.

4.3.4 Front Panel Interface

Provides parallel communication with the front panel.

4.3.5 GPIB Interface

Provides parallel communication with the GPIB port.

4.4 Power Supplies

AC power is supplied through the rear panel input power connector which provides in-line transient protection and RF filtering. The input power connector contains the fuses and the switch to select series or parallel connection of the transformer primaries for operation at 100 VAC, 120 VAC, 220 VAC, or 240 VAC.

4.4.1 TEC Power Supplies

There are two separate power supplies for the TEC. The linear supply provides analog and digital circuit power. The OEM switching supply provides the power to drive the TEC.

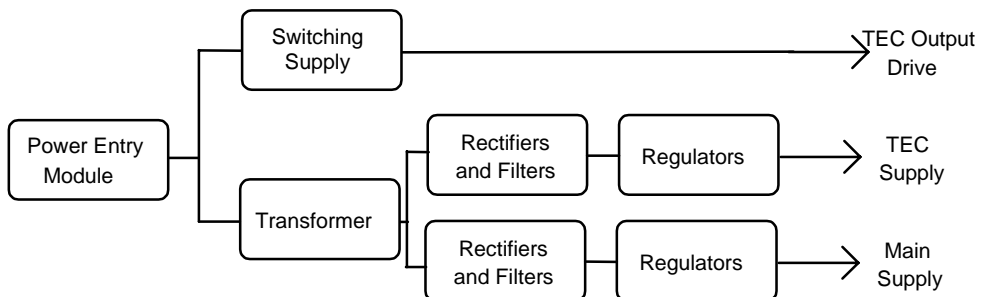

Figure 18 - Power Supply Block Diagram

4.4.2 Main Supply

This supply provides digital circuit power for all functions except the TEC. It also provides fan power.

5 Tips and Techniques

5.1 Introduction

This chapter is intended to further explain specific operational details of the Model 3150, as well as provide application examples.

5.2 TEC Limits

The TEC maintains several limits that control the operation of the unit. There are a total of five limits: I_{TE} current limit, high temperature limit, low temperature limit, high resistance/LM335 voltage/AD590 current limit (R/v/i), and low resistance/LM335 voltage/AD590 current limit.

Through the rest of this section, the resistance/LM335 voltage/AD590 current mode is collectively referred to as R mode, while the resistance/LM335 voltage/AD590 current limits are collectively referred to as the R limits.

I_{TE} Limit

The I_{TE} limit controls the maximum amount of current the TEC will drive while in any mode. The limit applies to both the positive and negative current drive. In temperature and R modes, it limits the amount of current that can be driven when controlling to the set point. In I_{TE} mode, it limits the set point to less than or equal to the limit. Unlike the temperature and R limits, the I_{TE} limit is controlled by hardware for immediate response.

Temperature Limits

The high and low temperature limits define the operating temperature range of the TEC, and are monitored while in any mode. The only case where temperature is not monitored is when a sensor type of “None” is selected. Temperature checking for high and low limits is done once per second, and when the system detects that a high or low temperature limit has been exceeded, it will shutdown the TEC output. Note, however, that clearing the appropriate bits in the TEC OUTOFF register through the GPIB or RS-232 interface can disable this automatic shutdown. The factory default is to shutdown the TEC on a temperature limit.

Resistance, LM335 Voltage, and AD590 Current Limits (R Limits)

In addition to temperature and current limits, the TEC also supports limits based on sensor values. R limits are monitored only when in the R mode, although as mentioned above, the T limits are monitored in any mode. R checking for high and low limits is done once per second. However, unlike a temperature limit, and when the system detects that a high or low R limit has been exceeded, by default it will *not* shutdown the TEC output. Note, however, that setting the appropriate bit in the TEC

OUTOFF register through the GPIB or RS-232 interface can enable this automatic shutdown. The factory default is to not shutdown the TEC on a R limit.

How a Sensor Change Affects R Values

Each time the sensor is changed, the old R limits and set point no longer apply to the new sensor. The 3150 calculates the new values for the upper and lower R limits and set point based on the temperature limits and set point. After the R values are initialized, changing the temperature limits or set point will not affect the corresponding R values until the next time the sensor type is changed.

6 Maintenance

6.1 Introduction

There are no user serviceable parts inside. Do not attempt to remove the cover.

6.2 Fuse Replacement

The fuses are accessible on the back panel of the 3150. Before replacing a fuse, turn power off and disconnect the line cord. Use only the fuses indicated below.

<u>Line Voltage</u>	<u>Fuse Replacement</u>
90-110 VAC	6 Amp, 3 AG, Slo-Blo, 250V
108-132 VAC	6 Amp, 3 AG, Slo-Blo, 250V
198-242 VAC	6 Amp, 3 AG, Slo-Blo, 250V
216-250 VAC	6 Amp, 3 AG, Slo-Blo, 250V

6.3 Cleaning

Use mild soap solution on a damp but not wet cloth. Disconnect AC power before cleaning.

7 Calibration

7.1 Calibration Overview

The 3150 performs an automatic calibration on power-up. This removes the majority of calibration error. However, if it is desired to completely calibrate the system, the following procedures will do so.

All calibrations are done with the case closed. The instrument is calibrated by changing the internally stored digital calibration constants.

All calibrations may be performed locally or remotely.

7.1.1 Environmental Conditions

Calibrate this instrument under laboratory conditions. We recommend calibration at $25^{\circ}\text{C} \pm 1.0^{\circ}\text{C}$. When necessary, however, the 3150 may be calibrated at its intended use temperature if this is within the specified operating temperature range of 0°C to 40°C .

7.1.2 Warm-Up

The 3150 should be allowed to warm up for at least 1 hour before calibration.

7.2 TEC Calibration

7.2.1 Recommended Equipment

Recommended test equipment for calibrating the TEC is listed in Table 5. Equipment other than that shown in the table may be used if the specifications meet or exceed those listed.

<u>Description</u>	<u>Mfg./Model</u>	<u>Specification</u>
DMM	HP34401A	DC Amps @ 1.0 A): $\pm 1\%$ Resistance (@ 10 ohms): 0.02%
Resistors	Metal Film	20 k Ω for 100 μ A calibration 200 k Ω for 10 μ A calibration 3 k Ω for LM335 sensor calibration 16 k Ω for AD590 sensor calibration 100 Ω for RTD sensor calibration
Resistor	High Power	1 Ω , 50 W, for current calibration
Connector	D-sub	15-pin male

Table 5 - Recommended Test Equipment

7.2.2

Local Operation Thermistor Calibration

- Measure and record the exact resistance of your metal film resistor. Use nominal values of 20 k Ω for the 100 μ A setting, and 200 k Ω for the 10 μ A setting. With the TEC output off, connect the metal film resistor to the sensor input of the TEC.
- Press the **Setup** soft key and select the appropriate thermistor (10 μ A or 100 μ A) as the sensor type.
- Go to the calibration display by first pressing the **MENU** button, then the **Config** soft key, then the **Cal** soft key. At the calibration screen, press the **Sensor** soft key. Follow the on-screen instructions to complete the calibration. The calibration can be terminated without affecting the stored constants if the **Term** soft key is pressed at any point prior to completing the calibration.

7.2.3

Remote Operation Thermistor Calibration

- Measure and record the exact resistance of your metal film resistor. Use nominal values of 20 k Ω for the 100 μ A setting, and 200 k Ω for the 10 μ A setting. With the TEC output off, connect the metal film resistor to the sensor input of the TEC Output connector.
- Send **TEC:SENS 1** 100 μ A thermistor, or **TEC:SENS 2** for the 10 μ A thermistor, followed by the **TEC:CAL:SEN** to enter sensor calibration mode.

The 3150 will be ready to receive the resistance when, after a **TEC:CAL:SEN?** query is sent, a “1” is returned.

- c. Input the actual resistance of the metal film resistor, in k Ω , (as an <nrf value>) via the **TEC:R <nrf value>** command.

If, at any time prior to **TEC:R**, a command other than **TEC:R** or **TEC:R?** is sent to the 3150, the 3150 will cancel the calibration mode and then process the command(s).

Once the **TEC:R** value is sent, the **OPC?** query may be used to determine when the calibration is completed. The operation complete flag (bit 0 of the Standard Event Status Register) may be used to trigger an interrupt. This type of interrupt is enabled by setting bit 0 of the Service Request Enable register and using the ***OPC** command.

7.2.4 Local Operation AD590 Sensor Calibration

- a. With the TEC output off, connect a precision 16 k Ω metal film resistor and a precision ammeter in series at the sensor input of the TEC Output connector.
- b. Press the **Setup** soft key and select the AD590 as the Sensor Type.
- c. Go to the calibration display by first pressing the **MENU** button, then the **Config** soft key, then the **Cal** soft key. At the calibration screen, press the **Sensor** soft key. Follow the on-screen instructions to complete the calibration. The calibration can be terminated without affecting the stored constants if the **Term** soft key is pressed at any point prior to completing the calibration.

7.2.5 Remote Operation AD590 Sensor Calibration

- a. With the TEC output off, connect a precision 16 k Ω metal film resistor and a precision ammeter in series at the sensor input of the TEC Output connector.
- b. Enter the **TEC:SEN 4** and **TEC:CAL:SEN** to select the AD590 sensor and enter sensor calibration mode.

The 3150 will be ready to receive the current value when, after a **TEC:CAL:SEN?** query is sent, the response from the 3150 is “1”.

- c. Input the actual current measured, in μ A, by the external ammeter (as an <nrf value>) via the **TEC:R <nrf value>** command.

If, at any time prior to **TEC:R**, a command other than **TEC:R** or **TEC:R?** is sent to the 3150, the 3150 will cancel the calibration mode and then process the command(s).

Once the **TEC:R** value is sent, the **OPC?** query may be used to determine when the calibration is completed. The operation complete flag (bit 0 of the Standard Event Status Register) may be used to trigger an interrupt. This type of interrupt is enabled by setting bit 0 of the Service Request Enable register and using the ***OPC** command.

7.2.6 Local Operation LM335 Sensor Calibration

- a. Use a 3 k Ω metal film resistor. With the TEC output off, connect the metal film resistor in parallel with a precision voltmeter to the sensor input of the TEC Output connector.
- b. Press the **Setup** soft key and select the LM335 as the Sensor Type.
- c. Go to the calibration display by first pressing the **MENU** button, then the **Config** soft key, then the **Cal** soft key. At the calibration screen, press the **Sensor** soft key. Follow the on-screen instructions to complete the calibration. The calibration can be terminated without affecting the stored constants if the **Term** soft key is pressed at any point prior to completing the calibration.

7.2.7 Remote Operation LM335 Sensor Calibration

- a. With the TEC output off, connect a 3 k Ω metal film resistor and a precision voltmeter in parallel at the sensor input of the TEC Output connector.
- b. Enter the **TEC:SEN 3** and **TEC:CAL:SEN** to select the LM335 sensor and enter sensor calibration mode.

The 3150 will be ready to receive the voltage value when, after a **TEC:CAL:SEN?** query is sent, the response from the 3150 is "1".

- c. Input the actual voltage, in mV, measured by the external voltmeter (as an <nrf value>) via the **TEC:R <nrf value>** command.

If, at any time prior to **TEC:R**, a command other than **TEC:R** or **TEC:R?** is sent to the 3150, the 3150 will cancel the calibration mode and then process the command(s).

Once the **TEC:R** value is sent, the **OPC?** query may be used to determine when the calibration is completed. The operation complete flag (bit 0 of the Standard Event Status Register) may be used to trigger

an interrupt. This type of interrupt is enabled by setting bit 0 of the Service Request Enable register and using the *OPC command.

7.2.8 Local Operation RTD Calibration

- a. Measure and record the exact resistance of your 100 Ω metal film resistor. With the TEC output off, connect the metal film resistor to the sensor input of the TEC Output connector.
- b. Press the **Setup** soft key and select the RTD as the Sensor Type.
- c. Go to the calibration display by first pressing the **MENU** button, then the **Config** soft key, then the **Cal** soft key. At the calibration screen, press the **Sensor** soft key. Follow the on-screen instructions to complete the calibration. The calibration can be terminated without affecting the stored constants if the **Term** soft key is pressed at any point prior to completing the calibration.

7.2.9 Remote Operation RTD Calibration

- a. Measure and record the exact resistance of your 100 Ω metal film resistor. With the TEC output off, connect the metal film resistor to the sensor input of the TEC Output connector.
- b. Send **TEC:SENS 5** to select the RTD sensor, followed by the **TEC:CAL:SEN** to enter sensor calibration mode.

The 3150 will be ready to receive the resistance when, after a **TEC:CAL:SEN?** query is sent, a "1" is returned.

- c. Input the actual resistance, in ohms, of the metal film resistor (as an <nrf value>) via the **TEC:R <nrf value>** command.

If, at any time prior to **TEC:R**, a command other than **TEC:R** or **TEC:R?** is sent to the 3150, the 3150 will cancel the calibration mode and then process the command(s).

Once the **TEC:R** value is sent, the **OPC?** query may be used to determine when the calibration is completed. The operation complete flag (bit 0 of the Standard Event Status Register) may be used to trigger an interrupt. This type of interrupt is enabled by setting bit 0 of the Service Request Enable register and using the *OPC command.

7.2.10 RTD Lead Resistance Calibration (Offset Null)

Because the RTD sensor reflects changes in temperature with small changes in resistance, even a small lead resistance (resistance caused by the wire running

between the TEC and the RTD sensor) can cause significant temperature offset. The lead resistance may be taken out of the RTD reading as follows:

- a. With the TEC output off, short the sensor wires as close to the RTD sensor as possible.
- b. Press the **Setup** soft key and select the RTD as the Sensor Type.
- c. Go to the calibration display by first pressing the **MENU** button, then the **Config** soft key, then the **Cal** soft key. At the calibration screen, press the **RTD Null** soft key. Follow the on-screen instructions to complete the calibration. The calibration can be terminated without affecting the stored constants if the **Term** soft key is pressed at any point prior to completing the calibration.

7.2.11 Local Operation I_{TE} Current Calibration

The following procedure is for calibrating the ITE constant current source for both polarities of current.

- a. With the output off, connect a 1Ω, 50W resistor and a calibrated ammeter in series across the output terminals. If an ammeter with the appropriate current ratings is unavailable, connect a 1Ω, 50W resistor across the output terminals and use a calibrated DMM to measure the voltage across the resistor. Calculate the current in the following steps by using Ohm's Law:

$$I = V / R$$

where V is the measured voltage across the resistor, and R is the measured load resistance.

- b. Go to the calibration display by first pressing the **MENU** button, then the **Config** soft key, then the **Cal** soft key. At the calibration screen, press the **ITE** soft key. Follow the on-screen instructions to complete the calibration. The calibration can be terminated without affecting the stored constants if the **Term** soft key is pressed at any point prior to completing the calibration.

7.2.12 Remote Operation I_{TE} Current Calibration

- a. With the output off, connect a 1Ω, 50W resistor and a calibrated ammeter in series across the output terminals. If an ammeter with the appropriate current ratings is unavailable, connect a 1Ω, 50W resistor across the output terminals and use a calibrated DMM to measure the voltage across the resistor. Calculate the current in the following steps by using Ohm's Law:

$$I = V / R$$

where V is the measured voltage across the resistor, and R is the measured load resistance.

- b. Send **TEC:CAL:ITE** to enter ITE calibration mode.

The TEC will be placed in ITE mode, limit set to 50% of full scale plus 100 mA, and the ITE set point set to 50% of full scale.

The 3150 will be ready to receive the first measured current value when, after a **TEC:CAL:ITE?** query is sent, a “1” is returned.

- c. Input the actual current (as an <nrf value>) via the **TEC:ITE <nrf value>** command. The 3150 will then drive the current to 25% of the initial set point.

The 3150 will be ready to receive the second measured current value when, after a **TEC:CAL:ITE?** query is sent, a “1” is returned.

- d. Input the second actual current (as an <nrf value>) via the **TEC:ITE <nrf value>** command. The 3150 will then drive the current to the negative current value of the initial set point.

The 3150 will be ready to receive the third measured current value when, after a **TEC:CAL:ITE?** query is sent, a “1” is returned.

- e. Input the third actual current (as an <nrf value>) via the **TEC:ITE <nrf value>** command. The 3150 will then drive the current to 25% of the negative current value of the initial set point.

The 3150 will be ready to receive the fourth measured current value when, after a **TEC:CAL:ITE?** query is sent, a “1” is returned.

- f. Input the fourth actual current (as an <nrf value>) via the **TEC:ITE <nrf value>** command.

If, at any time prior to the last **TEC:ITE**, a command other than **TEC:ITE** or **TEC:ITE?** is sent to the 3150, the 3150 will cancel the calibration mode and then process the command(s).

Once the **TEC:ITE** value is sent, the **OPC?** query may be used to determine when the calibration is completed. The operation complete flag (bit 0 of the Standard Event Status Register) may be used to trigger an interrupt. This type of interrupt is enabled by setting bit 0 of the Service Request Enable register and using the ***OPC** command.

8 **Factory Service**

8.1 **Introduction**

This section contains information regarding obtaining factory service for the Model 3150. The user should not attempt any maintenance or service of this instrument and/or accessories beyond the procedures given in chapters 6 and 7. Any problems which cannot be resolved using the guidelines listed in chapters 6 and 7 should be referred to Newport Corporation factory service personnel. Contact Newport Corporation or your Newport representative for assistance.

8.2 **Obtaining Service**

To obtain information concerning factory service, contact Newport Corporation or your Newport representative. Please have the following information available:

1. Instrument model number (On front panel)
2. Instrument serial number (On rear panel)
3. Description of the problem.

If the instrument is to be returned to Newport Corporation, you will be given a Return Materials Authorization (RMA) number, which you should reference in your shipping documents as well as clearly marked on the outside of the shipping container.

Please fill out the service form, located on the following page, and have the information ready when contacting Newport Corporation. Return the completed service form with the instrument.

Service Form

Newport Corporation
USA Office: 949/863-3144
FAX: 949/253-1800

Name _____

RETURN AUTHORIZATION # _____

Company _____

(Please obtain prior to return of item)

Address _____

Country _____

Date _____

P.O. Number _____

Phone Number _____

Item(s) being returned:

Model # _____

Serial # _____

Description _____

Reason for return of goods (please list any specific problems) _____

List all control settings and describe problem _____

_____ (Attach additional sheets as necessary)

Show a block diagram on the backside of this page of your measurement system including all instruments connected (whether power is turned on or not). Describe signal source. If source is laser, describe output mode, peak power, pulse width, and repetition rate.

Where is measurement being performed?

(factory, controlled laboratory, out-of-doors, etc.) _____

What power line voltage is used? _____ Variation? _____

Frequency? _____ Ambient Temperature? _____

Any additional information. (If special modifications have been made by the user, please describe below)

Error Messages

9.1 Introduction

Error messages may appear on the display when error conditions occur in the respective functions of the 3150. For example, a current limit error in the TEC will be displayed.

In remote operation, the current error list can be read by issuing the "ERR?" query. When this is done, a string will be returned containing all of the error messages which are currently in the error message queue.

The errors codes are numerically divided into areas of operation as shown below.

<u>Error Code Range</u>	<u>Area of Operation</u>
E-001 to E-099	Internal Program Errors
E-100 to E-199	Parser Errors
E-200 to E-299	Execution Control Errors
E-300 to E-399	GPIB/RS232 Errors
E-400 to E-499	TEC Control Errors

Table 6 contains all of the error messages which may be generated by the 3150. Not all of these messages may be displayed. Some refer to GPIB activities only, for example.

Table 6 - Error Codes

<u>Error Code</u>	<u>Explanation</u>
E-001	Memory allocation failure.
E-002	Floating point error
E-104	Numeric type not defined.
E-106	Digit expected.
E-107	Digit not expected.
E-115	Identifier not valid.
E-116	Parser syntax error, character was not expected.
E-126	Too few or too many program data elements.
E-201	Value out of range.
E-214	Length exceeds maximum.
E-217	Attempted to recall a bin from a unsaved position.
E-218	Additional link could not be added to the link table because the link table is already full.
E-301	A response message was ready, but controller failed to read it.
E-302	3150 is talker, but controller didn't read entire message.

<u>Error Code</u>	<u>Explanation</u>
E-303	Input buffer overflow
E-304	Output buffer overflow
E-305	Parser buffer overflow
E-402	Sensor open disabled output.
E-403	TEC open disabled output.
E-404	TEC Current limit disabled output.
E-405	TEC Voltage limit disabled output.
E-406	TEC resistance/reference limit disabled output
E-407	TEC high temperature limit disabled output.
E-409	Sensor change disabled output.
E-410	TEC out of tolerance disabled output.
E-415	Sensor short disabled output.
E-416	Incorrect Configuration for Calibration Sequence to start.
E-417	TEC output must be on to begin calibration.
E-418	TEC C1, C2, or C3 constants are bad, all set to default values.
E-419	Mode change disabled output.
E-431	TEC link condition forced output on
E-432	TEC link condition forced output off
E-900	Calculation Error shutdown output
E-901	System over temperature shutdown all outputs
E-903	Loading of a saved bin shutdown TEC output

10 Specifications

10.1 Temperature Controller Specifications

<u>Specifications</u>	<u>3150</u>
TEC Output	
Maximum Current / Voltage	15 Amps at 23 Volts <i>or</i> 12.5 Amps at 28 Volts
Maximum Power	350 Watts
TE Current Resolution (mA)	0.458
TE Current Accuracy (mA)	± (3 % set point + 50 mA)
Current Limit	
Range	0 to 15 Amps
Accuracy	± 150 mA
Ripple/Noise (rms)	< 10 mA
Short Term Stability (1 hour)	< 0.0005 °C
Long Term Stability (24 hour)	< 0.001 °C
Temperature Coefficient (°C/°C)	< 0.05
Display	
Range	
Temperature	-100.00°C to +240.00°C
Resistance (10 µA)	0.01 kΩ to 495.000 kΩ
Resistance (100 µA)	0.001 kΩ to 49.500 kΩ
Resistance (RTD)	20 Ω to 192 Ω
LM335 Voltage	2331 mV to 3731 mV
AD590 Current	248.15 µA to 378.15 µA
TE Current	± 15.00 Amps
TE Voltage	0.0 to 30.0 Volts
Resolution	
Temperature	0.01 °C
Resistance (10 µA)	10 Ω
Resistance (100 µA)	1 Ω
Resistance (RTD)	0.01 Ω
LM335 Voltage	0.1 mV
AD590 Current	0.01 µA
TE Current	10 mA
TE Voltage	0.1 Volts
Accuracy³	
Temperature	± 0.1 °C
Resistance (10 µA)	± (0.04% + 16 Ω)
Resistance (100 µA)	± (0.05% + 8 Ω)
Resistance (RTD)	± (0.03% + 50 mΩ)
LM335 Voltage	± (0.09% + 1 mV)
AD590 Current	± (0.005% + 0.5 uA)
TE Current	± (0.25% + 30 mA)
TE Voltage	± (0.005% + 100 mV)

³ ± (% of reading + fixed error)

Temperature Sensors	Thermistors	AD590	LM335	RTD (100Ω)
Temp Control Resolution	0.01 °C	0.01 °C	0.01 °C	0.01 °C
Temp Control Accuracy	± 0.05 °C	± 0.05 °C	± 0.05 °C	± 0.05 °C ⁴
Sensor Bias Current or Voltage	10 μA/100 μA	+5 Volts	1 mA	1 mA

Temperature Calibration

Thermistor	$1/T = (C1 \times 10^{-3}) + (C2 \times 10^{-4})(\ln R) + (C3 \times 10^{-7})(\ln R)^3$
AD590	$T = C1 + C2 \times (I_{AD590}/1\mu A/K - 273.15)$
LM335	$T = C1 + C2 \times (V_{LM335}/10mV/K - 273.15)$
Pt RTD	$R_T = R_o [1 + C1 * T + C2 * T^2] ; T \geq 0 \text{ } ^\circ\text{C},$ $R_T = R_o [1 + C1 * T + C2 * T^2 + C3 * T^3 * (T - 100)] ; T < 0 \text{ } ^\circ\text{C}$ Ro = resistance at 0 °C where, Ro=100Ω for a 100Ω Pt RTD.

10.2 General Specifications

Display	
Type	LCD character display, 4 lines by 20 characters
Back Lighting	Green LED
Controls	Brightness and Contrast (contrast optimizes viewing angle)
Channel Active	Green LDD LED indicates that temperature controller output is on.
Output Connectors	
Temperature Controller (TEC)	High Power 7W2 female D-sub
Chassis Ground	4 mm Banana Jack
GPIB Connector	24 pin IEEE-488
RS232 Connector	9-pin male D-sub
Power Requirements	90 to 132V, 6A Max.; 198 to 250V, 3A Max. (user selectable), 50 to 60 Hz
Size (H x W x D)	86 mm x 356 mm x 356 mm (3.5 " x 14" x 14")
Mainframe Weight	5.9 kg (14 lbs.)
Operating Temperature	0 to 40°C, < 80% relative humidity non-condensing
Storage Temperature	-20°C to 60°C, < 90% relative humidity non-condensing
Isolation	TEC electrically isolated with respect to earth ground.

In accordance with ongoing efforts to continuously improve our products, Newport Corporation reserves the right to modify product specifications without notice and without liability for such changes.

⁴ Accuracy is with lead wire resistance calibrated out.



Artisan Technology Group is your source for quality new and certified-used/pre-owned equipment

- FAST SHIPPING AND DELIVERY
- TENS OF THOUSANDS OF IN-STOCK ITEMS
- EQUIPMENT DEMOS
- HUNDREDS OF MANUFACTURERS SUPPORTED
- LEASING/MONTHLY RENTALS
- ITAR CERTIFIED SECURE ASSET SOLUTIONS

SERVICE CENTER REPAIRS

Experienced engineers and technicians on staff at our full-service, in-house repair center

*InstraView*SM REMOTE INSPECTION

Remotely inspect equipment before purchasing with our interactive website at www.instraview.com ↗

WE BUY USED EQUIPMENT

Sell your excess, underutilized, and idle used equipment. We also offer credit for buy-backs and trade-ins. www.artisanng.com/WeBuyEquipment ↗

LOOKING FOR MORE INFORMATION?

Visit us on the web at www.artisanng.com ↗ for more information on price quotations, drivers, technical specifications, manuals, and documentation

Contact us: (888) 88-SOURCE | sales@artisanng.com | www.artisanng.com