



## Artisan Technology Group is your source for quality new and certified-used/pre-owned equipment

- FAST SHIPPING AND DELIVERY
- TENS OF THOUSANDS OF IN-STOCK ITEMS
- EQUIPMENT DEMOS
- HUNDREDS OF MANUFACTURERS SUPPORTED
- LEASING/MONTHLY RENTALS
- ITAR CERTIFIED SECURE ASSET SOLUTIONS

### SERVICE CENTER REPAIRS

Experienced engineers and technicians on staff at our full-service, in-house repair center

### *InstraView*<sup>SM</sup> REMOTE INSPECTION

Remotely inspect equipment before purchasing with our interactive website at [www.instraview.com](http://www.instraview.com) ↗

### WE BUY USED EQUIPMENT

Sell your excess, underutilized, and idle used equipment. We also offer credit for buy-backs and trade-ins. [www.artisanng.com/WeBuyEquipment](http://www.artisanng.com/WeBuyEquipment) ↗

### LOOKING FOR MORE INFORMATION?

Visit us on the web at [www.artisanng.com](http://www.artisanng.com) ↗ for more information on price quotations, drivers, technical specifications, manuals, and documentation

**Contact us:** (888) 88-SOURCE | [sales@artisanng.com](mailto:sales@artisanng.com) | [www.artisanng.com](http://www.artisanng.com)

Last Revised: 2011-04-14 16:59:41.0

## Real-Time Controller with 256 MB DRAM, 2 GB Storage

### NI cRIO-9022



- Small and rugged real-time embedded controller
- Execution target for LabVIEW Real-Time applications
- Reliable and deterministic operation for stand-alone control, monitoring, and logging
- 533 MHz Freescale MPC8347 real-time processor
- Dual Ethernet ports for deterministic expansion I/O
- -20 to 55 °C operating temperature range
- RS232 serial port for connection to peripherals; dual 9 to 35 VDC supply inputs
- Hi-Speed USB host port for connection to USB flash and memory devices

### Overview

The NI cRIO-9022 embedded real-time controller is part of the high-performance CompactRIO programmable automation controller (PAC) platform. It features an industrial 533 MHz Freescale MPC8347 real-time processor for deterministic, reliable real-time applications and contains 256 MB of DDR2 RAM and 2 GB of nonvolatile storage for holding programs and logging data.

[Back to Top](#)

### Requirements and Compatibility

#### OS Information

- VxWorks

#### Driver Information

- NI-RIO

#### Software Compatibility

- LabVIEW
- LabVIEW FPGA Module
- LabVIEW Professional Development System
- LabVIEW Real-Time Module

[Back to Top](#)

### Application and Technology

#### System Configuration

The NI cRIO-9022 controller features an industrial 533 MHz Freescale MPC8347 real-time processor for deterministic and reliable real-time applications. This embedded controller is designed for extreme ruggedness, reliability, and low power consumption with dual 9 to 35 VDC supply inputs that deliver isolated power to the CompactRIO chassis and a -20 to 55 °C operating temperature range. The cRIO-9022 accepts 9 to 35 VDC power supply inputs on power-up and 6 to 35 VDC power supply inputs during operation, so it can function for long periods of time in remote applications using a battery or solar power. With the 10/100 Mbps and 10/100/1000 Mbps Ethernet and serial ports, you can communicate via TCP/IP, UDP, Modbus/TCP, and serial protocols. The cRIO-9022 also features built-in Web (HTTP) and file (FTP) servers and a Hi-Speed USB host port to which you can connect external USB-based storage media (flash drives and hard drives) for embedded logging applications requiring more data storage. In addition, the cRIO-9022 incorporates a fault-tolerant file system that provides increased reliability for data logging. CompactRIO real-time controllers connect to any four- or eight-slot NI cRIO-911x reconfigurable chassis. The embedded field-programmable gate array (FPGA) in the chassis controls each I/O module and passes data to the controller through a local PCI bus using built-in communications functions.

The CompactRIO real-time controller connects to any four- or eight-slot CompactRIO reconfigurable chassis. The user-defined FPGA circuitry in the chassis controls each I/O module and passes data to the controller through a local PCI bus, using built-in communication functions.

## Embedded Software

The cRIO-9022 runs NI LabVIEW Real-Time Module software on the Wind River VxWorks real-time operating system (RTOS) for extreme reliability and determinism. You can now use leading VxWorks RTOS technology and LabVIEW graphical programming tools to quickly design, prototype, and deploy a customizable, commercial off-the-shelf embedded system.

You can synchronize embedded code execution to an FPGA-generated interrupt request (IRQ) or an internal millisecond real-time clock source. The LabVIEW Real-Time ETS OS provides reliability and simplifies the development of complete embedded applications that include time-critical control and acquisition loops in addition to lower-priority loops for postprocessing, data logging, and Ethernet/serial communication. Built-in elemental I/O functions such as the FPGA Read/Write function provide a communication interface to the highly optimized reconfigurable FPGA circuitry. Data values are read from the FPGA in integer format and then converted to scaled engineering units in the controller.

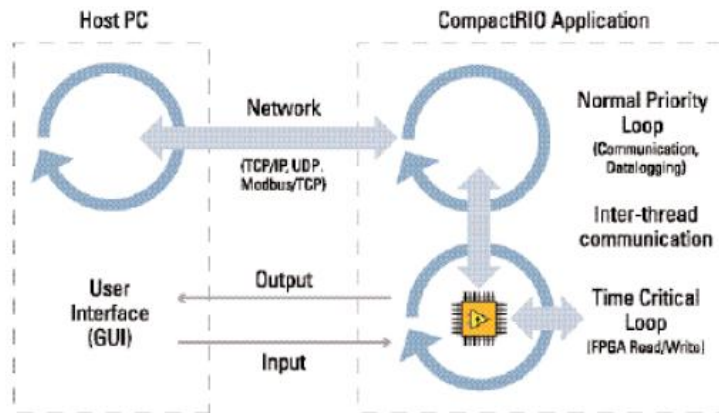

Figure 1. CompactRIO Software Architecture

## Built-In Servers

In addition to programmatic communication via TCP/IP, UDP, Modbus/TCP, IrDA, and serial protocols, the CompactRIO controllers include built-in servers for Virtual Instrument Software Architecture (VISA), HTTP, and FTP. The VISA server provides remote download and communication access to the reconfigurable I/O (RIO) FPGA over Ethernet. The HTTP server provides a Web browser user interface to HTML pages, files, and the user interface of embedded LabVIEW applications through a Web browser plug-in. The FTP server provides access to logged data or configuration files.

[Back to Top](#)

## Ordering Information

For a complete list of accessories, visit the product page on ni.com.

Products	Part Number	Recommended Accessories	Part Number
<b>NI cRIO-9022</b>			
cRIO-9022, Real-Time PowerPC Controller for cRIO, 533 MHz	780718-01	Connector Block: Not Applicable - NI 9978 4-pos screw terminal power supply plugs (quantity 5)	196938-01
Requires:		Connector Block: Not Applicable - NI 9979 Strain relief kit for 4-pos power connector	196939-01

[Back to Top](#)

## Software Recommendations

### LabVIEW Professional Development System for Windows

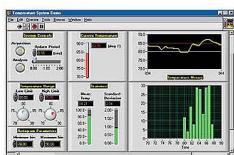

- Advanced software tools for large project development
- Automatic code generation using DAQ Assistant and Instrument I/O Assistant
- Tight integration with a wide range of hardware
- Advanced measurement analysis and digital signal processing
- Open connectivity with DLLs, ActiveX, and .NET objects
- Capability to build DLLs, executables, and MSI installers

### NI LabVIEW FPGA Module

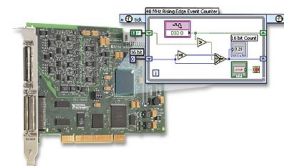

- Create your own I/O hardware without VHDL coding or board design
- Graphically configure FPGAs on NI reconfigurable I/O (RIO) hardware targets
- Define your own control algorithms with loop rates up to 200 MHz
- Execute multiple tasks simultaneously and deterministically
- Implement custom timing and triggering logic, digital protocols, and DSP algorithms
- Incorporate existing HDL code and third-party IP including Xilinx CORE Generator functions

## NI LabVIEW Real-Time Module

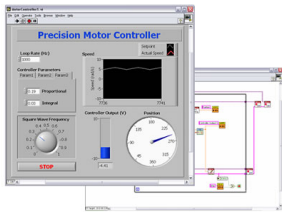

- Design deterministic real-time applications with LabVIEW graphical programming
- Download to dedicated NI or third-party hardware for reliable execution and a wide selection of I/O
- Take advantage of built-in PID control, signal processing, and analysis functions
- Automatically take advantage of multicore CPUs or set processor affinity manually
- Includes real-time operating system (RTOS), development and debugging support, and board support
- Purchase individually or as part of an NI Developer Suite bundle

[Back to Top](#)

## Support and Services

### System Assurance Programs

NI system assurance programs are designed to make it even easier for you to own an NI system. These programs include configuration and deployment services for your NI PXI, CompactRIO, or Compact FieldPoint system. The NI Basic System Assurance Program provides a simple integration test and ensures that your system is delivered completely assembled in one box. When you configure your system with the NI Standard System Assurance Program, you can select from available NI system driver sets and application development environments to create customized, reorderable software configurations. Your system arrives fully assembled and tested in one box with your software preinstalled. When you order your system with the standard program, you also receive system-specific documentation including a bill of materials, an integration test report, a recommended maintenance plan, and frequently asked question documents. Finally, the standard program reduces the total cost of owning an NI system by providing three years of warranty coverage and calibration service. Use the online product advisors at [ni.com/advisor](http://ni.com/advisor) to find a system assurance program to meet your needs.

### Calibration

NI measurement hardware is calibrated to ensure measurement accuracy and verify that the device meets its published specifications. NI offers a number of calibration services to help maintain the ongoing accuracy of your measurement hardware. These services allow you to be completely confident in your measurements, and help you maintain compliance to standards like ISO 9001, ANSI/NCSL Z540-1 and ISO/IEC 17025. To learn more about NI calibration services or to locate a qualified service center near you, contact your local sales office or visit [ni.com/calibration](http://ni.com/calibration).

### Technical Support

Get answers to your technical questions using the following National Instruments resources.

- **Support** - Visit [ni.com/support](http://ni.com/support) to access the NI KnowledgeBase, example programs, and tutorials or to contact our applications engineers who are located in NI sales offices around the world and speak the local language.
- **Discussion Forums** - Visit [forums.ni.com](http://forums.ni.com) for a diverse set of discussion boards on topics you care about.
- **Online Community** - Visit [community.ni.com](http://community.ni.com) to find, contribute, or collaborate on customer-contributed technical content with users like you.

### Repair

While you may never need your hardware repaired, NI understands that unexpected events may lead to necessary repairs. NI offers repair services performed by highly trained technicians who quickly return your device with the guarantee that it will perform to factory specifications. For more information, visit [ni.com/repair](http://ni.com/repair).

### Training and Certifications

The NI training and certification program delivers the fastest, most certain route to increased proficiency and productivity using NI software and hardware. Training builds the skills to more efficiently develop robust, maintainable applications, while certification validates your knowledge and ability.

- **Classroom training in cities worldwide** - the most comprehensive hands-on training taught by engineers.
- **On-site training at your facility** - an excellent option to train multiple employees at the same time.
- **Online instructor-led training** - lower-cost, remote training if classroom or on-site courses are not possible.
- **Course kits** - lowest-cost, self-paced training that you can use as reference guides.
- **Training memberships** and training credits - to buy now and schedule training later.

Visit [ni.com/training](http://ni.com/training) for more information.

### Extended Warranty

NI offers options for extending the standard product warranty to meet the life-cycle requirements of your project. In addition, because NI understands that your requirements may change, the extended warranty is flexible in length and easily renewed. For more information, visit [ni.com/warranty](http://ni.com/warranty).

### OEM

NI offers design-in consulting and product integration assistance if you need NI products for OEM applications. For information about special pricing and services for OEM customers, visit [ni.com/oem](http://ni.com/oem).

### Alliance

Our Professional Services Team is comprised of NI applications engineers, NI Consulting Services, and a worldwide National Instruments Alliance Partner program of more than 600 independent consultants and integrators. Services range from start-up assistance to turnkey system integration. Visit [ni.com/alliance](http://ni.com/alliance).

## Detailed Specifications

The following specifications are typical for the entire operating temperature range, – 20 to 55 °C, unless otherwise noted.

### Network

Network interface	
Ethernet port 1	10BaseT, 100BaseTX, and 1000BaseTX Ethernet
Ethernet port 2	10BaseT and 100BaseTX Ethernet
Compatibility	IEEE 802.3
Communication rates	
Ethernet port 1	10 Mbps, 100 Mbps, and 1000 Mbps, auto-negotiated
Ethernet port 2	10 Mbps, 100 Mbps, auto-negotiated
Maximum cabling distance	100 m/segment

### RS-232 DTE Serial Port

Baud rate	300–230,400 bps
Data bits	5, 6, 7, 8
Stop bits	1, 1.5, 2
Parity	Odd, even, mark, space, none
Flow control	RTS/CTS, XON/XOFF, DTR/DSR, none

### USB Port

Maximum data rate	480 Mb/s
Maximum current	500 mA

### Memory

Nonvolatile	2 GB
-------------	------

For information about the life span of the nonvolatile memory and about best practices for using nonvolatile memory, go to [ni.com/info](http://ni.com/info) and enter the info code SSDBP.

DRAM	256 MB
------	--------

### Internal Real-Time Clock

Accuracy	200 ppm; 35 ppm at 25 °C
----------	--------------------------

### Integrated Voltage Input Monitor

The integrated voltage input monitor underreports the voltage at the power connector by up to 400 mV because of voltage drops across internal circuits.

### Power Requirements

 **Caution** You must use a National Electric Code (NEC) UL Listed Class 2 power supply with the cRIO-9022.

Recommended power supply	55 W secondary, 35 VDC max
Power consumption with controller supplying power to eight CompactRIO modules	35 W
Voltage requirement	
On powerup	9 to 35 V
After powerup	6 to 35 V

 **Note** The cRIO-9022 is guaranteed to power up when 9 V is applied to V and C. After powerup, it can operate on as little as 6 V.

### Physical Characteristics

If you need to clean the controller, wipe it with a dry towel.	
Screw-terminal wiring	12–18 AWG copper conductor wire with 10 mm (0.39 in.) of insulation stripped from the end
Torque for screw terminals	0.5 to 0.6 N · m (4.4 to 5.3 lb · in.)

Weight Approx. 609 g (21.5 oz)

## Environmental

The cRIO-9022 is intended for indoor use only. For outdoor use, mount the CompactRIO system in a suitably rated enclosure.

Operating temperature (IEC 60068-2-1, IEC 60068-2-2) – 20 to 55 °C

 **Caution** For information about how mounting configuration can affect the accuracy of C Series modules, go to [ni.com/info](http://ni.com/info) and enter the info code rdcriotemp.

Storage temperature (IEC 60068-2-1, IEC 60068-2-2) – 40 to 85 °C

Ingress protection IP 40

Operating humidity (IEC 60068-2-56) 10 to 90% RH, noncondensing

Storage humidity (IEC 60068-2-56) 5 to 95% RH, noncondensing

Maximum altitude 2,000 m

Pollution Degree (IEC 60664) 2

## Shock and Vibration

To meet these specifications for shock and vibration, you must panel mount or wall mount the CompactRIO system, affix ferrules to the ends of all terminal wires, install a strain relief on the power cable, and install tie wraps on the Ethernet and power cables. You can order the NI 9979, a strain-relief kit for the power cable, from National Instruments. The kit is NI part number 196939-01. For information about using the USB port in high shock and vibration environments, contact National Instruments.

Operating vibration

Random (IEC 60068-2-64) 5 g<sub>rms</sub>, 10 to 500 Hz

Sinusoidal (IEC 60068-2-6) 5 g, 10 to 500 Hz

Operating shock (IEC 60068-2-27) 30 g, 11 ms half sine, 50 g, 3 ms half sine, 18 shocks at 6 orientations

## Safety

### Safety Voltages

Connect only voltages that are within these limits.

V-to-C 35 V max, Measurement Category I

Measurement Category I is for measurements performed on circuits not directly connected to the electrical distribution system referred to as MAINS voltage. MAINS is a hazardous live electrical supply system that powers equipment. This category is for measurements of voltages from specially protected secondary circuits. Such voltage measurements include signal levels, special equipment, limited-energy parts of equipment, circuits powered by regulated low-voltage sources, and electronics.

 **Caution** Do not connect to signals or use for measurements within Measurement Categories II, III, or IV.

### Safety Standards

This product is designed to meet the requirements of the following standards of safety for electrical equipment for measurement, control, and laboratory use:

- IEC 61010-1, EN 61010-1
- UL 61010-1, CSA 61010-1

 **Note** For UL and other safety certifications, refer to the product label or the *Online Product Certification* section.

### Hazardous Locations

U.S. (UL) Class I, Division 2, Groups A, B, C, D, T4; Class I, Zone 2, AEx nA IIC T4

Canada (C-UL) Class I, Division 2, Groups A, B, C, D, T4; Class I, Zone 2, Ex nA IIC T4

Europe (DEMKO) Ex nA IIC T4

## Electromagnetic Compatibility

This product meets the requirements of the following EMC standards for electrical equipment for measurement, control, and laboratory use:

- EN 61326 (IEC 61326): Class A emissions; Industrial Immunity
- EN 55011 (CISPR 11): Group 1, Class A emissions
- AS/NZS CISPR 11: Group 1, Class A emissions
- FCC 47 CFR Part 15B: Class A emissions
- ICES-001: Class A emissions

 **Note** For the standards applied to assess the EMC of this product, refer to the *Online Product Certification* section.

 **Note** For EMC compliance, operate this product according to the documentation.

## CE Compliance

This product meets the essential requirements of applicable European Directives, as amended for CE marking, as follows:

- 2006/95/EC; Low-Voltage Directive (safety)
- 2004/108/EC; Electromagnetic Compatibility Directive (EMC)

## Online Product Certification

Refer to the product Declaration of Conformity (DoC) for additional regulatory compliance information. To obtain product certifications and the DoC for this product, visit [ni.com/certification](http://ni.com/certification), search by module number or product line, and click the appropriate link in the Certification column.

## Environmental Management

National Instruments is committed to designing and manufacturing products in an environmentally responsible manner. NI recognizes that eliminating certain hazardous substances from our products is beneficial not only to the environment but also to NI customers.

For additional environmental information, refer to the *NI and the Environment* Web page at [ni.com/environment](http://ni.com/environment). This page contains the environmental regulations and directives with which NI complies, as well as other environmental information not included in this document.

## Waste Electrical and Electronic Equipment (WEEE)



**EU Customers** At the end of the product life cycle, all products *must* be sent to a WEEE recycling center. For more information about WEEE recycling centers, National Instruments WEEE initiatives, and compliance with WEEE Directive 2002/96/EC on Waste Electrical and Electronic Equipment, visit [ni.com/environment/weee.htm](http://ni.com/environment/weee.htm).

### 电子信息产品污染控制管理办法（中国 RoHS）



**中国客户** National Instruments 符合中国电子信息产品中限制使用某些有害物质指令 (RoHS)。关于 National Instruments 中国 RoHS 合规性信息，请登录 [ni.com/environment/rohs\\_china](http://ni.com/environment/rohs_china)。(For information about China RoHS compliance, go to [ni.com/environment/rohs\\_china](http://ni.com/environment/rohs_china).)

## Cabling

The following table shows the standard Ethernet cable wiring connections.

Ethernet Cable Wiring Connections		
Pin	Connector 1	Connector 2
1	white/orange	white/orange
2	orange	orange
3	white/green	white/green
4	blue	blue
5	white/blue	white/blue
6	green	green
7	white/brown	white/brown
8	brown	brown

[Back to Top](#)

## Pinouts/Front Panel Connections

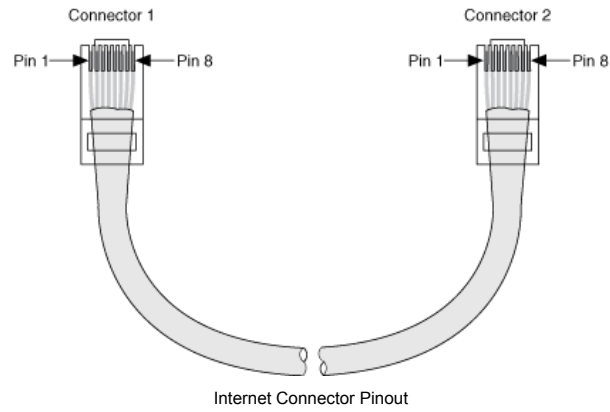

[Back to Top](#)

---

©2010 National Instruments. All rights reserved. CompactRIO, FieldPoint, LabVIEW, National Instruments, National Instruments Alliance Partner, NI, and ni.com are trademarks of National Instruments. Other product and company names listed are trademarks or trade names of their respective companies. A National Instruments Alliance Partner is a business entity independent from National Instruments and has no agency, partnership, or joint-venture relationship with National Instruments.

[My Profile](#) | [RSS](#) | [Privacy](#) | [Legal](#) | [Contact NI](#) © 2012 National Instruments Corporation. All rights reserved.





## Artisan Technology Group is your source for quality new and certified-used/pre-owned equipment

- FAST SHIPPING AND DELIVERY
- TENS OF THOUSANDS OF IN-STOCK ITEMS
- EQUIPMENT DEMOS
- HUNDREDS OF MANUFACTURERS SUPPORTED
- LEASING/MONTHLY RENTALS
- ITAR CERTIFIED SECURE ASSET SOLUTIONS

### SERVICE CENTER REPAIRS

Experienced engineers and technicians on staff at our full-service, in-house repair center

### *InstraView*<sup>SM</sup> REMOTE INSPECTION

Remotely inspect equipment before purchasing with our interactive website at [www.instraview.com](http://www.instraview.com) ↗

### WE BUY USED EQUIPMENT

Sell your excess, underutilized, and idle used equipment. We also offer credit for buy-backs and trade-ins. [www.artisanng.com/WeBuyEquipment](http://www.artisanng.com/WeBuyEquipment) ↗

### LOOKING FOR MORE INFORMATION?

Visit us on the web at [www.artisanng.com](http://www.artisanng.com) ↗ for more information on price quotations, drivers, technical specifications, manuals, and documentation

**Contact us:** (888) 88-SOURCE | [sales@artisanng.com](mailto:sales@artisanng.com) | [www.artisanng.com](http://www.artisanng.com)