

# FieldPoint™ Operating Instructions

## FP-DI-300 and cFP-DI-300

### Eight-Channel, 24 V Digital Input Module

These operating instructions describe how to install and use the National Instruments FP-DI-300 and cFP-DI-300 digital input modules (referred to inclusively as the [c]FP-DI-300). For information about configuring and accessing the [c]FP-DI-300 over a network, refer to the user manual for the FieldPoint network module you are using.

## Features

---

The [c]FP-DI-300 is a FieldPoint digital input module with the following features:

- Eight digital input channels
- Sinking inputs compatible with 24 VDC sourcing outputs
- On/Off LED indicators
- 250 V<sub>rms</sub> CAT II continuous channel-to-ground isolation, verified by 2,300 V<sub>rms</sub>, 5 s dielectric withstand test
- -40 to 70 °C operation
- Hot swappable

## Installing the FP-DI-300

---

The FP-DI-300 mounts on a FieldPoint terminal base (FP-TB-*x*), which provides operating power to the module. Installing the FP-DI-300 onto a powered terminal base does not disrupt the operation of the FieldPoint bank.

To install the FP-DI-300, refer to Figure 1 and complete the following steps:

1. Slide the terminal base key to either position X (used for any module) or position 5 (used for the FP-DI-300 module).
2. Align the FP-DI-300 alignment slots with the guide rails on the terminal base.

3. Press firmly to seat the FP-DI-300 on the terminal base. When the module is firmly seated, the terminal base latch locks it into place.

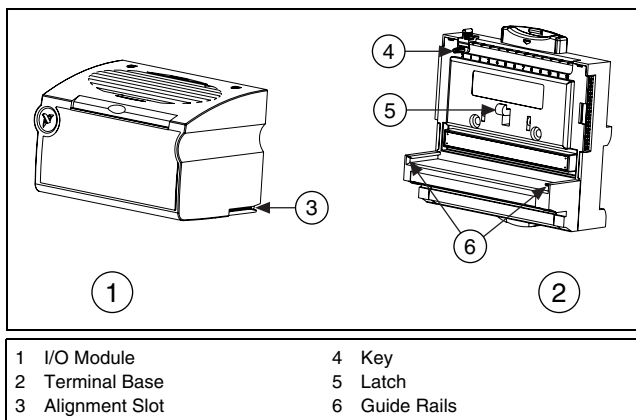

**Figure 1.** Installing the FP-DI-300

## Installing the cFP-DI-300

The cFP-DI-300 mounts on a Compact FieldPoint backplane (cFP-BP-*x* or cFP-180*x*), which provides operating power to the module. Installing the cFP-DI-300 onto a powered backplane does not disrupt the operation of the FieldPoint bank.

To install the cFP-DI-300, refer to Figure 2 and complete the following steps:

1. Align the captive screws on the cFP-DI-300 with the holes on the backplane. The alignment keys on the cFP-DI-300 prevent backward insertion.
2. Press firmly to seat the cFP-DI-300 on the backplane.
3. Using a number 2 Phillips screwdriver with a shank of at least 64 mm (2.5 in.) length, tighten the captive screws to 1.1 N · m (10 lb · in.) of torque. The nylon coating on the screws prevents them from loosening.

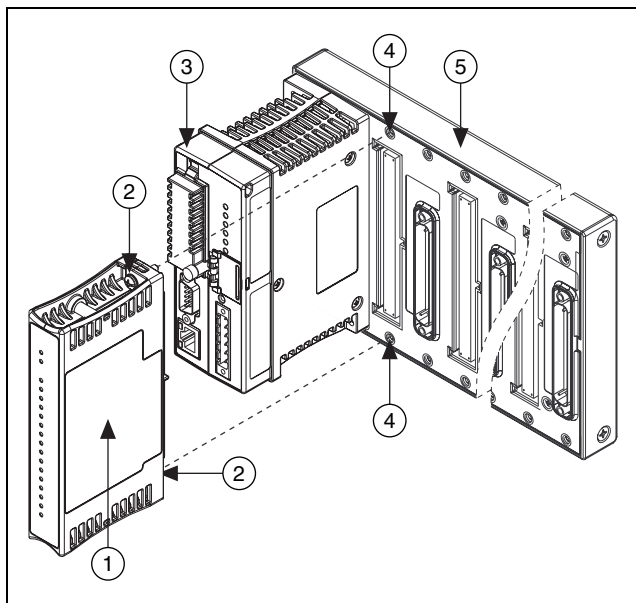

- |                         |                 |
|-------------------------|-----------------|
| 1 I/O Module            | 4 Screw Holes   |
| 2 Captive Screws        | 5 cFP Backplane |
| 3 cFP Controller Module |                 |

**Figure 2.** Installing the cFP-DI-300

## Wiring the [c]FP-DI-300

The FP-TB-*x* terminal base has connections for each of the eight input channels of the FP-DI-300 and for an external power supply to power field devices. The cFP-CB-*x* connector block provides the same connections for the cFP-DI-300. Each channel has one input terminal,  $V_{IN}$ . All eight inputs are referenced to the COM terminals, which are internally connected to each other and to the C terminals. All eight  $V_{SUP}$  terminals are internally connected to each other and to the V terminals.

Use a 15–30 VDC external power supply to power field devices. Connect the external power supply to multiple V and  $V_{SUP}$  terminals so that the maximum current through any V terminal is 2 A or less and the maximum current through any  $V_{SUP}$  terminal is 1 A or less.

Install a 2 A maximum, fast-acting fuse between the external power supply and the V terminal on each channel. The wiring diagrams in this document show fuses where appropriate.

Table 1 lists the terminal assignments for the signals associated with each channel. The terminal assignments are the same for the FP-TB-*x* terminal bases and the cFP-CB-*x* connector blocks.

**Table 1.** Terminal Assignments

Channel	Terminal Numbers		
	V <sub>IN</sub>	V <sub>SUP</sub> <sup>1</sup>	COM
0	1	17	18
1	3	19	20
2	5	21	22
3	7	23	24
4	9	25	26
5	11	27	28
6	13	29	30
7	15	31	32

<sup>1</sup> Install a 1 A maximum, fast-acting fuse on each connected V<sub>SUP</sub> terminal. Install a 2 A maximum, fast-acting fuse on each connected V terminal.



**Caution** Cascading power between two modules defeats isolation between those modules. Cascading power from the network module defeats all isolation between modules in the FieldPoint bank.

You can wire each channel for use with a *sourcing-output* device. A sourcing-output device provides a path to a voltage source.

Figure 3 shows how to connect a three-wire sourcing-output device to one channel of the [c]FP-DI-300. In this wiring configuration, the external power supply is connected to the V and C terminals. The output device sources power to the  $V_{IN}$  terminal.

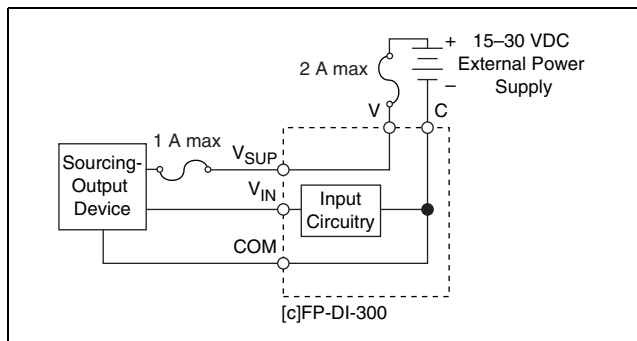

**Figure 3.** Connection to Sourcing-Output Device

Figure 4 shows how to connect a limit switch to one channel of the [c]FP-DI-300.

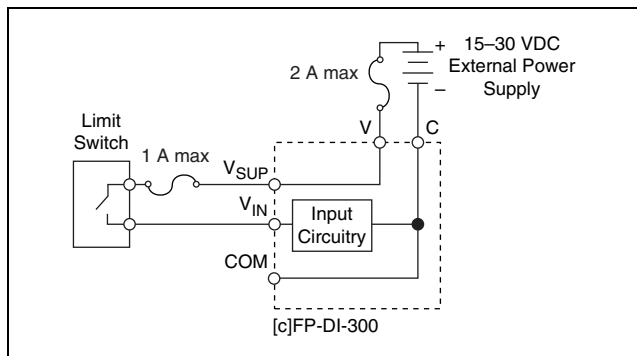

**Figure 4.** Connection to Limit Switch

Alternatively, you can connect an external power supply as shown in Figure 5.

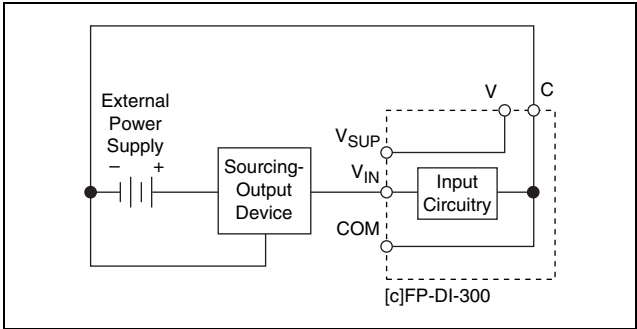

**Figure 5.** Connection to Externally Powered Sourcing-Output Device



**Note** You *must* use the same ground for all of the channels on the [c]FP-DI-300.

## Digital Input Circuit

The [c]FP-DI-300 has eight current-limited input channels. You can connect a voltage signal to each channel. All eight input channels share a common ground reference that is isolated from other modules in the FieldPoint system.

When you apply a voltage above 15 V to a  $V_{IN}$  terminal, current flows through that terminal and turns on the optical isolator, registering as an ON condition for the channel. When you apply a voltage below 5 V to a  $V_{IN}$  terminal, the channel registers an OFF condition. When you apply a voltage between 5 and 15 V, the channel may or may not register an ON condition.

The [c]FP-DI-300 has *sinking* inputs, which means that current flows through the  $V_{IN}$  terminal to the COM terminal. The inputs are compatible with sourcing-output devices capable of sourcing or driving current from a positive supply voltage to common. A sensor is an example of a sourcing-output device.

Figure 3 shows how to connect to sourcing-output devices. These devices should have OFF-state leakage currents of less than 1 mA to ensure that they do not provide false ON state readings to the [c]FP-DI-300.

# Status Indicators

---

The [c]FP-DI-300 has two green status LEDs, **POWER** and **READY**. After you install the [c]FP-DI-300 onto a terminal base or backplane and apply power to the connected network module, the green **POWER** indicator lights and the [c]FP-DI-300 informs the network module of its presence. When the network module recognizes the [c]FP-DI-300, it sends initial configuration information to the [c]FP-DI-300. After the [c]FP-DI-300 receives this initial information, the green **READY** indicator lights and the module is in normal operating mode.

In addition to the green **POWER** and **READY** indicators, each channel has a numbered green status indicator that lights when the channel is in the ON state.

## Isolation and Safety Guidelines

---



**Caution** Read the following information before attempting to connect the [c]FP-DI-300 to any circuits that may contain *hazardous voltages*.<sup>1</sup>

This section describes the isolation of the [c]FP-DI-300 and its compliance with international safety standards. The field wiring connections are isolated from the backplane and the inter-module communication bus. The isolation barriers in the module provide 250 V<sub>rms</sub> Measurement Category II continuous channel-to-backplane and channel-to-ground isolation, verified by a 2,300 V<sub>rms</sub>, 5 s dielectric withstand test.<sup>2</sup> The [c]FP-DI-300 provides *double insulation* compliant with IEC 61010-1 for working voltages of 250 V<sub>rms</sub>.<sup>3</sup> Safety standards (such as those published by UL and IEC) require the use of double insulation between hazardous voltages and any human-accessible parts or circuits.

---

<sup>1</sup> A hazardous voltage is a voltage greater than 42.4 V<sub>peak</sub> or 60 VDC. When a hazardous voltage is present on any channel, all of the channels must be considered to be carrying hazardous voltages. Ensure that all circuits connected to the module are inaccessible to human touch.

<sup>2</sup> Refer to the [Isolation Voltage](#) section for more information about isolation on the [c]FP-DI-300.

<sup>3</sup> *Working voltage* is defined as the signal voltage plus the common-mode voltage. *Common-mode voltage* is the voltage of the module with respect to ground.

*Never* try to use any isolation product between human-accessible parts (such as DIN rails or monitoring stations) and circuits that can be at hazardous potentials under normal conditions, unless the product is specifically designed for such an application, as is the [c]FP-DI-300.

Even though the [c]FP-DI-300 is designed to handle applications with hazardous potentials, follow these guidelines to ensure a safe total system:

- There is no isolation between channels on the [c]FP-DI-300. If a hazardous voltage is present on any channel, all channels are considered hazardous. Make sure that all other devices and circuits connected to the module are properly insulated from human contact.
- Do *not* share the external supply voltages (the V and C terminals) with other devices, including other FieldPoint devices, unless those devices are isolated from human contact.
- For Compact FieldPoint, you *must* connect the protective earth (PE) ground terminal on the cFP-BP-*x* backplane to the system safety ground. The backplane PE ground terminal has the following symbol stamped beside it:  $\oplus$ . Connect the backplane PE ground terminal to the system safety ground using 14 AWG (1.6 mm) wire with a ring lug. Use the 5/16 in. panhead screw shipped with the backplane to secure the ring lug to the backplane PE ground terminal.
- As with any hazardous voltage wiring, make sure that all wiring and connections meet applicable electrical codes and commonsense practices. Mount terminal bases and backplanes in an area, position, or cabinet that prevents accidental or unauthorized access to wiring that carries hazardous voltages.
- Do *not* use the [c]FP-DI-300 as the only isolating barrier between human contact and working voltages higher than  $250 V_{\text{rms}}$ .
- Operate the [c]FP-DI-300 only at or below Pollution Degree 2. Pollution Degree 2 means that only nonconductive pollution occurs in most cases. Occasionally, however, temporary conductivity caused by condensation must be expected.
- Operate the [c]FP-DI-300 at or below Measurement Category II. Measurement Category II is for measurements performed on circuits directly connected to the low-voltage installation. This category refers to local-level distribution, such as that provided by a standard wall outlet.



## Safety Guidelines for Hazardous Locations

The cFP-DI-300 is suitable for use in Class I, Division 2, Groups A, B, C, D, T4 hazardous locations; Class I, Zone 2, AEx nC IIC T4 and Ex nC IIC T4 hazardous locations; and nonhazardous locations only. Follow these guidelines if you are installing the cFP-DI-300 in a potentially explosive environment. Not following these guidelines may result in serious injury or death.



**Caution** Do *not* disconnect I/O-side wires or connectors unless power has been switched off or the area is known to be nonhazardous.



**Caution** Do *not* remove modules unless power has been switched off or the area is known to be nonhazardous.



**Caution** Substitution of components may impair suitability for Class I, Division 2.



**Caution** For Zone 2 applications, install the Compact FieldPoint system in an enclosure rated to at least IP 54 as defined by IEC 60529 and EN 60529.



**Caution** For Zone 2 applications, install a protection device across the external power supply and the COM terminal. The device must prevent the external power supply voltage from exceeding 42 V if there is a transient overvoltage condition.

## Special Conditions for Hazardous Locations Use in Europe

This equipment has been evaluated as EEx nC IIC T4 equipment under DEMKO Certificate No. 03 ATEX 0251502X. Each module is marked  $\text{Ex}$  II 3G and is suitable for use in Zone 2 hazardous locations.



**Caution** For Zone 2 applications, connected signals must be within the following limits:

Capacitance ..... 0.2  $\mu\text{F}$  max

## Specifications

---

These specifications are typical for the range  $-40$  to  $70$  °C unless otherwise noted. Specifications are subject to change without notice.

## Input Characteristics

Number of channels .....	8
Input type .....	24 VDC sinking inputs
Reverse voltage protection.....	-30 VDC
Input OFF range.....	<5 VDC
Input ON range .....	15 to 30 VDC
Input impedance.....	5 k $\Omega$
Current sink per channel	

Logic Level	Minimum	Maximum
ON state	3 mA	6 mA
OFF state	-6 mA	1 mA

## Physical Characteristics

Indicators .....	Green <b>POWER</b> and <b>READY</b> indicators, 8 green input state indicators
------------------	---

### Weight

FP-DI-300.....	140 g (4.93 oz)
cFP-DI-300.....	110 g (3.88 oz)

## Power Requirements

Power from network module .....	225 mW
---------------------------------	--------

## Isolation Voltage

Isolation voltage is verified by a dielectric withstand test.

### Channel-to-ground isolation

Continuous .....	250 V <sub>rms</sub> , Measurement Category II
------------------	---

Dielectric withstand.....	2,300 V <sub>rms</sub> , 5 s max
---------------------------	----------------------------------

Channel-to-channel isolation .....	None
------------------------------------	------

## Environmental

FieldPoint modules are intended for indoor use only. For outdoor use, they must be mounted inside a sealed enclosure.

Operating temperature .....	-40 to 70 °C
-----------------------------	--------------

Storage temperature .....	-55 to 85 °C
---------------------------	--------------

Humidity .....	10 to 90% RH, noncondensing
Maximum altitude.....	2,000 m
Pollution Degree .....	2

## Shock and Vibration

These specifications apply only to the cFP-DI-300. NI recommends Compact FieldPoint if your application is subject to shock and vibration.

Operating vibration, random (IEC 60068-2-64).....	10–500 Hz, 5 g <sub>rms</sub>
Operating vibration, sinusoidal (IEC 60068-2-6).....	10–500 Hz, 5 g
Operating shock (IEC 60068-2-27).....	50 g, 3 ms half sine, 18 shocks at 6 orientations; 30 g, 11 ms half sine, 18 shocks at 6 orientations

## Safety

This product is designed to meet the requirements of the following standards of safety for electrical equipment for measurement, control, and laboratory use:

- IEC 61010-1, EN-61010-1
- UL 61010-1, CSA 61010-1



**Note** For UL and other safety certifications, refer to the product label or visit [ni.com/certification](http://ni.com/certification), search by model number or product line, and click the appropriate link in the Certification column.

## Electromagnetic Compatibility

This product is designed to meet the requirements of the following standards of EMC for electrical equipment for measurement, control, and laboratory use:

- EN 61326 EMC requirements; Industrial Immunity
- EN 55011 Emissions; Group 1, Class A
- CE, C-Tick, ICES, and FCC Part 15 Emissions; Class A



**Note** For EMC compliance, operate this product with shielded cabling.

## CE Compliance

This product meets the essential requirements of applicable European Directives, as amended for CE marking, as follows:

- 73/23/EEC; Low-Voltage Directive (safety)
- 89/336/EEC; Electromagnetic Compatibility Directive (EMC)



**Note** Refer to the Declaration of Conformity (DoC) for this product for any additional regulatory compliance information. To obtain the DoC for this product, visit [ni.com/certification](http://ni.com/certification), search by model number or product line, and click the appropriate link in the Certification column.

## Waste Electrical and Electronic Equipment (WEEE)



**EU Customers** At the end of their life cycle, all products *must* be sent to a WEEE recycling center. For more information about WEEE recycling centers and National Instruments WEEE initiatives, visit [ni.com/environment/weee.htm](http://ni.com/environment/weee.htm).

## Mechanical Dimensions

Figure 6 shows the mechanical dimensions of the FP-DI-300 installed on a terminal base. If you are using the cFP-DI-300, refer to the Compact FieldPoint controller user manual for the dimensions and cabling clearance requirements of the Compact FieldPoint system.

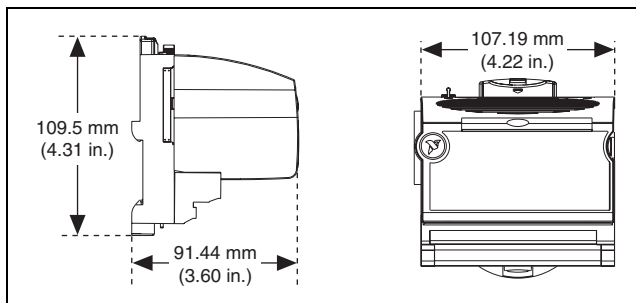

**Figure 6.** FP-DI-300 Mechanical Dimensions

# Where to Go for Support

---

For more information about setting up the FieldPoint system, refer to these National Instruments documents:

- FieldPoint network module user manual
- Other FieldPoint I/O module operating instructions
- FieldPoint terminal base and connector block operating instructions

Go to [ni.com/support](http://ni.com/support) for the most current manuals, examples, and troubleshooting information.

National Instruments corporate headquarters is located at 11500 North Mopac Expressway, Austin, Texas, 78759-3504. National Instruments also has offices located around the world to help address your support needs. For telephone support in the United States, create your service request at [ni.com/support](http://ni.com/support) and follow the calling instructions or dial 512 795 8248. For telephone support outside the United States, contact your local branch office:

Australia 1800 300 800, Austria 43 0 662 45 79 90 0,  
Belgium 32 0 2 757 00 20, Brazil 55 11 3262 3599,  
Canada 800 433 3488, China 86 21 6555 7838,  
Czech Republic 420 224 235 774, Denmark 45 45 76 26 00,  
Finland 385 0 9 725 725 11, France 33 0 1 48 14 24 24,  
Germany 49 0 89 741 31 30, India 91 80 41190000,  
Israel 972 0 3 6393737, Italy 39 02 413091,  
Japan 81 3 5472 2970, Korea 82 02 3451 3400,  
Lebanon 961 0 1 33 28 28, Malaysia 1800 887710,  
Mexico 01 800 010 0793, Netherlands 31 0 348 433 466,  
New Zealand 0800 553 322, Norway 47 0 66 90 76 60,  
Poland 48 22 3390150, Portugal 351 210 311 210,  
Russia 7 095 783 68 51, Singapore 1800 226 5886,  
Slovenia 386 3 425 4200, South Africa 27 0 11 805 8197,  
Spain 34 91 640 0085, Sweden 46 0 8 587 895 00,  
Switzerland 41 56 200 51 51, Taiwan 886 02 2377 2222,  
Thailand 662 278 6777, United Kingdom 44 0 1635 523545

National Instruments, NI, ni.com, and LabVIEW are trademarks of National Instruments Corporation. Refer to the *Terms of Use* section on [ni.com/legal](http://ni.com/legal) for more information about National Instruments trademarks. Other product and company names mentioned herein are trademarks or trade names of their respective companies. For patents covering National Instruments products, refer to the appropriate location: **Help»Patents** in your software, the `patents.txt` file on your CD, or [ni.com/patents](http://ni.com/patents).

© 2002–2006 National Instruments Corp. All rights reserved.