

# Operating Instructions

Industrial Color CCD Camera  
**GP-KS152**



**Panasonic®**

Before attempting to connect or operate this product, please read these instructions completely.

# CONTENTS

PREFACE .....	1
FEATURES .....	1
PRECAUTIONS .....	2
SYSTEM BLOCK DIAGRAM .....	3
MAJOR OPERATING CONTROLS AND THEIR FUNCTIONS .....	3
PREPARATIONS .....	5
CONNECTIONS .....	6
INSTALLATIONS .....	7
SETUP PROCEDURE .....	8
PREVENTION OF BLOOMING AND SMEAR .....	22
SPECIFICATIONS .....	22
STANDARD ACCESSORIES .....	23
OPTIONAL ACCESSORIES .....	23



**CAUTION**

RISK OF ELECTRIC SHOCK  
DO NOT OPEN



**CAUTION:**  
TO REDUCE THE RISK OF ELECTRIC SHOCK, DO NOT REMOVE COVER (OR BACK). NO USER SERVICEABLE PARTS INSIDE. REFER SERVICING TO QUALIFIED SERVICE PERSONNEL.



The lightning flash with arrowhead symbol, within an equilateral triangle, is intended to alert the user to the presence of uninsulated "dangerous voltage" within the product's enclosure that may be of sufficient magnitude to constitute a risk of electric shock to persons.



The exclamation point within an equilateral triangle is intended to alert the user to the presence of important operating and maintenance (servicing) instructions in the literature accompanying the appliance.

..... For U.S.A .....

**Warning:**  
This equipment generates and uses radio frequency energy and if not installed and used properly, i.e., in strict accordance with the instruction manual, may cause harmful interference to radio communications. It has been tested and found to comply with the limits for a Class A computing device pursuant to Subpart J of Part 15 of FCC Rules, which are designed to provide reasonable protection against such interference when operated in a commercial environment.

..... For CANADA .....

This digital apparatus does not exceed the Class A limits for radio noise emissions from digital apparatus set out in the Radio Interference Regulations of the Canadian Department of Communications.

The serial number of this product may be found on the bottom of the unit.  
You should note the serial number of this unit in the space provided and retain this book as a permanent record of your purchase to aid identification in the event of theft.

Model No. \_\_\_\_\_

Serial No. \_\_\_\_\_

**WARNING:**  
TO PREVENT FIRE OR SHOCK HAZARD, DO NOT EXPOSE THIS APPLIANCE TO RAIN OR MOISTURE.

## PREFACE

The Panasonic GP-KS152 Color Digital Micro-Camera overcomes space limitations that have complicated many video applications. Weighing only 0.04 lbs. (16g), this remarkably compact CCTV camera measures only two-thirds inches in diameter and two inches in length. It can easily be separated from its control unit using an optional cable (GP-CA56, GP-CA57).

So the exceptionally maneuverable GP-KS152 lets you obtain a whole new world of camera angles and shots that were once quite difficult to achieve. With the 330,000-element, 1/2-inch CCD pick-up device, horizontal resolution is more than 430 lines, and signal-to-noise ratio is 46 dB. An AGC Selection Button and Gain Selection Button, lets you obtain clear, high-quality color images in light as low as 0.5 footcandle at F1.6 (5 lux). In addition, this camera utilize various user setup menu using on-screen character display.

## FEATURES

1. 1/2 inch Interline CCD image sensor with 682 (H) x 492 (V) pixels.
2. 430 lines of horizontal resolution.
3. 0.5 footcandle at F1.6 (5 lux) of minimum scene illumination.
4. 46 dB of signal to noise ratio.
5. Selectable from Auto Tracing White balance (ATW), Auto White balance control (AWC) or manual white balance control.
6. Gen-lock capability.
7. Automatic gain control (AGC) ON/OFF and sensitivity up ON/OFF.
8. 12V DC operation.
9. Optional Wide-Angle Lens, Pinhole Lens or Telephoto-Lens can be used.
10. Optional C-mount lens can be used with optional C-mount adaptor.
11. Either GP-CA56 (6.7 ft) cable or GP-CA57 (33 ft) cable can be connected between the camera head and camera control unit.
12. S-VHS Video Output.
13. Character Generator Input.
14. Selectable of the function from the Direct Mode and the Setup Mode.

## PRECAUTIONS

- Do not attempt to disassemble the camera or camera control unit.  
To prevent electric shock, do not remove screws or cover. There are no user-serviceable parts inside. Refer servicing to qualified service personnel.
- Do not expose the camera or camera control unit to rain or moisture, or try to operate it in wet areas. Do take immediate action if ever the camera or camera control unit do become wet. Turn power off and refer servicing to qualified service personnel. Moisture can damage the camera and camera control unit and also create the danger of electric shock.
- Ambient Temperature range.  
Do not install the camera in the place which is beyond 14°F - 104°F (-10°C - +40°C).
- Do not drop anything inside the camera.  
Dropping metal for example inside the camera could permanently damage the unit.
- Never crush or pinch the camera cable.  
Do not bend the camera cable into a curve whose radius is too small.
- Never face the camera toward the sun.  
Whether the camera is in use or not, never face it toward the sun. Do use caution when operating the camera in the vicinity of spot lights or other bright lights and light reflecting objects.
- How to take care of this camera.  
After turning off the Power ON/OFF Switch, clean it with a dry cloth. If it is difficult to remove the dirt or dusts, clean it up with a cloth applied the neutral cleanser. Use the lens cleaning tissue paper (may be available at your local camera store) for lens cleaning.
- Connect this unit to a DC 12V, CLASS 2 Power Supply only.
- After using the camera, turn off the Power ON/OFF Switch and put the Lens cap on the camera head.
- Connect the camera head and camera control unit which are packed in the same box (a pair). Otherwise it would cause a improper operation.
- Every necessary procedures with regard to install this product should be made by qualified Service Personnel or System Installers.

### Cautions :

1. Connecting or disconnecting camera cable to/from the camera control unit must be done after turning OFF the Power ON/OFF Switch.
2. Use either GP-CA56 or GP-CA57 camera cable only to connect it between the camera head and camera control unit. Do not extend the cable.

# SYSTEM BLOCK DIAGRAM

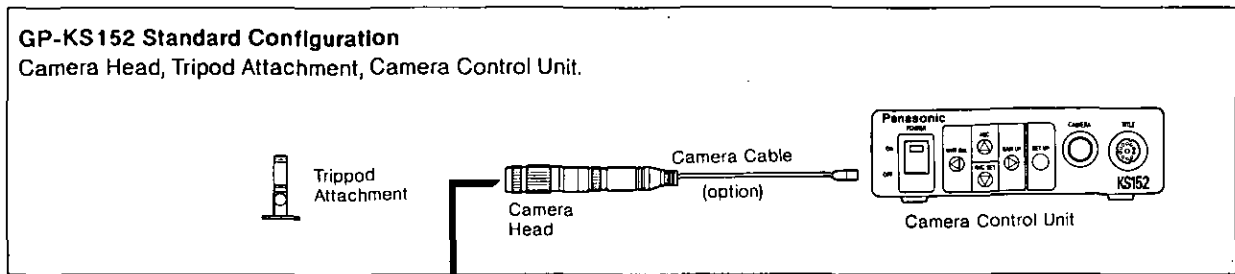

## Optional Accessories

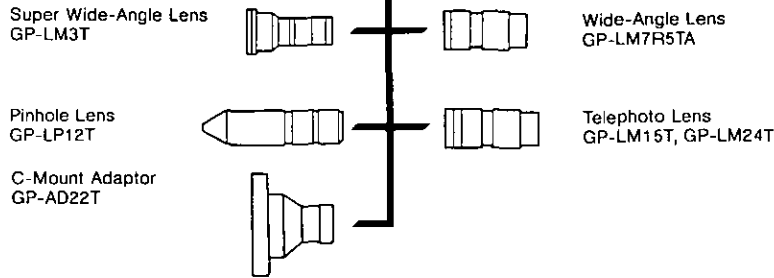

# MAJOR OPERATING CONTROLS AND THEIR FUNCTIONS

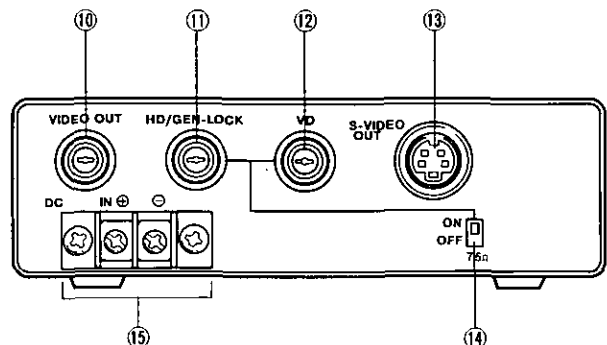
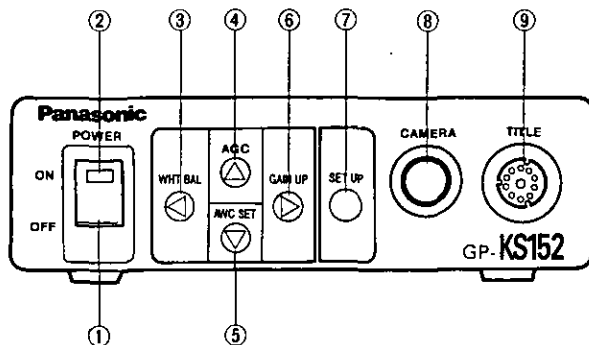

### 1. Power ON/OFF Switch (ON/OFF)

### 2. Power Indicator (POWER)

### 3. White Balance Mode Selection Button (WHT BAL)

This button is used to select the white balance mode as follows. (See page 8 for Direct Mode and page 9 for Setup Menu.)

#### ATW :

The Auto Tracing White Balance Control (ATW) mode is selected. The white balance is automatically and continuously set by detecting the characteristic/color temperature of light source through the lens and controlling the gain of red and blue signal even if the characteristic/color temperature varies.

### Notes :

- It is recommended to use the ATW position when the color temperature of light would vary during shooting.
- It is recommended to use the AWC or MANU position in the following conditions.
  - Under fluorescent lamp
  - Color temperature does not vary
  - More accurate white balance control is required.

### MANU :

Manual white balance control mode is selected. The white balance can be adjusted with the Red (R) and Blue (B) Gain Control under the Setup mode.

**AWC :**

Auto White Balance Control (AWC) mode is selected. Pressing the Auto White Balance Control Button (AWC SET) (5), the white balance can be set automatically while aiming the camera at a white object such as white paper or white wall etc.

**Note :**

It is recommended to use the MANU position in the following condition.

- Under low illumination
- Under colored illumination
- Under fluorescent lamp
- No white object is available

**4. AGC Selection Button (AGC)**

This button is used to select the gain of video amplifier as follows. (See page 8 for Direct Mode and page 9 for Setup Menu.)

**OFF :**

The automatic gain control (AGC) is disabled and the gain of video amplifier is set to the fixed value.

**LOW :**

The video gain increases approximately +6 dB.

**MID :**

The video gain increases approximately +9 dB.

**HI :**

The video gain increases approximately +12 dB.

**5. Auto White Balance Control Button (AWC SET)**

The white balance can be set by pressing this button. See page 8 for Direct Mode and page 9 Setup Menu.

**6. Gain Selection Button (GAIN UP)**

This button is used to select the gain of the video amplifier as follows. (See page 8 for Direct Mode and page 9 for Setup Menu.)

**OFF :**

The gain of the video amplifier is set to the fixed value.

**LOW :**

The video gain increases approximately +6 dB.

**MID :**

The video gain increases approximately +9 dB.

**HI :**

The video gain increases approximately +12 dB.

**7. Setup Mode Button (SET UP)**

The camera enters to the user setup-mode by pressing this button.

**8. Camera Cable Connector (CAMERA)**

This 12-pin connector is used for connection of the optional camera cable.

**Caution :**

Connecting or disconnecting the camera cable must be done after turning off the Power ON/OFF Switch.

**9. Title Input Connector (TITLE)**

This connector is used to connect the optional Character Generator WJ-KB12 or WJ-KB15.

**Note :**

The black & white characters are displayed on the video monitor. No color is available.

**10. Video Output Connector (VIDEO OUT)**

A 1.0 Vp-p/75 ohms composite video signal is provided at the connector.

**11. Horizontal Drive/Gen-Lock Input Connector (HD/GEN-LOCK) (Gen-Lock Mode)**

The color video signal of the camera is automatically synchronized to the gen-lock signal (composite or black burst) which is supplied to this connector. The gen-lock signal is used for system reference.

**Caution :**

If the gen-lock signal is jittery (when obtained from VTR playback), the camera can not be able to synchronize properly.

(External HD and VD Mode)

The horizontal and vertical phase of the color video signal is synchronized to the external HD fed to this connector and external VD fed to the Vertical Drive (VD) Input Connector (12).

**CAUTION :**

Camera functions improperly when only HD or only VD is fed to the camera control unit.

**12. Vertical Drive Input Connector (VD)**

Feed the external Vertical Drive pulse to this connector.

**13. S-VHS Video Output Connector (S-VIDEO OUT)**

The luminance (Y) and chroma (C) signals for S-VHS VTR or monitor are provided at this connector.

**14. Gen lock Termination Switches (G/L 75 ohms, ON/OFF)**

When looping through the gen-lock video input signal, set this switch to the OFF position and other cases, set this to the ON position.

**15. 12V DC Input Terminals (DC 12V IN)**

This terminal accept an external DC source supplying nominal power of 12V, 0.5A-0.7A.

**CAUTION :**

CONNECT THIS TO A DC 12V CLASS 2 POWER SUPPLY ONLY.

**Caution :**

To Prevent fire or shock hazard, the UL listed wire VW-1, style 1007 should be used for the cable for DC 12V Input Terminal.

## PREPARATIONS

### Caution :

Keep the Power ON/OFF Switch of the camera in the OFF position throughout the installation.

### GP-KS152 with GP-LM3T, GP-LM7R5TA, GP-LM15T, GP-LM24T or GP-LP12T

1. Remove the front cap of the camera head and confirm that the surface of the optical filter of the camera head is clean.

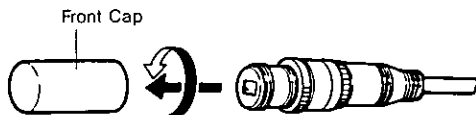

If the surface of the optical filter is dirty or dusts are on it, clean it up with a blower brush which is for film camera lenses (may be available at your local camera store) or supplied lens cleaning tissue paper.

2. Rotate the focus lock ring fully clockwise. Mount the Lens to the camera by rotating it clockwise slowly.

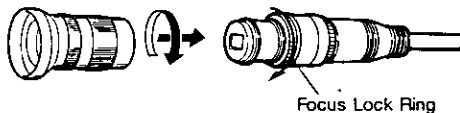

### GP-KS152 with GP-AD22T and Optional C-mount Lens

1. Remove the front cap of the camera head and confirm that the surface of the optical filter of the camera head is clean.

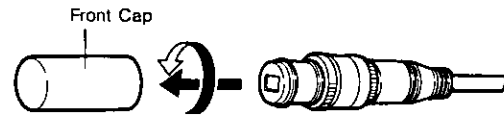

If the surface of the optical filter is dirty or dusts are on it, clean it up with a blower brush which is for film camera lenses (may be available at your local camera store) or supplied lens cleaning tissue paper.

2. Attach the optional C-mount lens to the C-mount adaptor GP-AD22T by rotating it clockwise.



3. Rotate the focus lock ring fully clockwise. Mount the lens and C-mount adaptor by rotating them clockwise slowly.

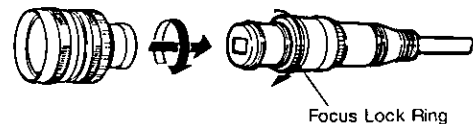

### Caution :

If the optional C-mount lens size exceeds 2" (50.8 mm) in diameter, 2-3/4" (70 mm) in length and 0.66 lbs (300 g) in weight, both the camera and lens should be secured.

# CONNECTIONS

## Cautions :

1. Keep the Power ON/OFF Switch in the OFF position until all connections have been properly made.
2. Connect the optional camera cable between the camera head and camera control unit which are packed in the same box (a pair) unless otherwise it would cause a improper operation.

## Internal Sync Operation

1. Connect the optional camera cable between the camera head and the camera control unit.
2. Connect the coaxial cable with BNC connectors between the Video Output Connector (10) of the camera control unit and the video monitor or VTR.

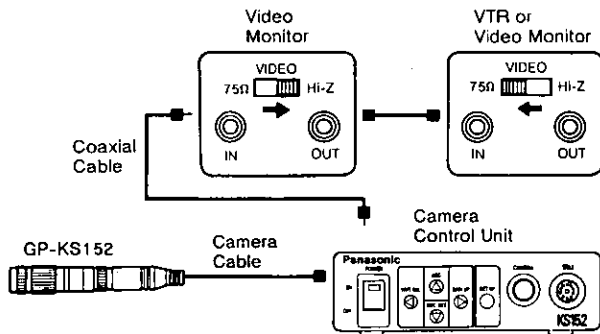

3. Connect the power cable between the 12V DC Input Terminals and the power supply of 12V DC (sold separately).
- Calculation method of maximum cable length between camera and power supply.

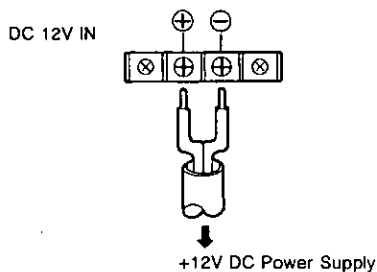

- Calculation method of maximum cable length between camera and power supply.

$$10.5V DC \leq V_A - (R \times 0.42 \times L) \leq 16V DC$$

L: Cable length (meter)

R: Resistance of copper wire (ohms/meter)

V<sub>A</sub>: DC output voltage of power supply

$$L_{\text{standard}} = \frac{V_A - 12}{0.42 \times R} \text{ (Meter)}$$

$$L_{\text{minimum}} = \frac{V_A - 16}{0.42 \times R} \text{ (Meter)}$$

$$L_{\text{maximum}} = \frac{V_A - 10.5}{0.42 \times R} \text{ (Meter)}$$

## CAUTION :

CONNECT THIS TO A 12V DC CLASS 2 POWER SUPPLY ONLY.

## Caution :

To Prevent fire or shock hazard, the UL listed wire VW-1, style 1007 should be used for the cable for 12V DC Input Terminal.

## Gen-lock Operation

1. Connect the optional camera cable between the camera head and the camera control unit.
2. Connect the coaxial cables with BNC connectors between the Video Output connector (10) of camera control unit and the Video Input of Special Effects Generator, and between the Black Burst Output connector of SEG and the Gen-Lock Input connector (11) of camera control unit.
3. Connect the power cable between the 12V DC Input Terminals and the Power Supply of 12V DC (sold separately).

## CAUTION :

CONNECT THIS TO A 12V DC CLASS 2 POWER SUPPLY ONLY.

## Caution :

To Prevent fire or shock hazard, the UL listed wire VW-1, style 1007 should be used for the cable for 12V DC Input Terminal.

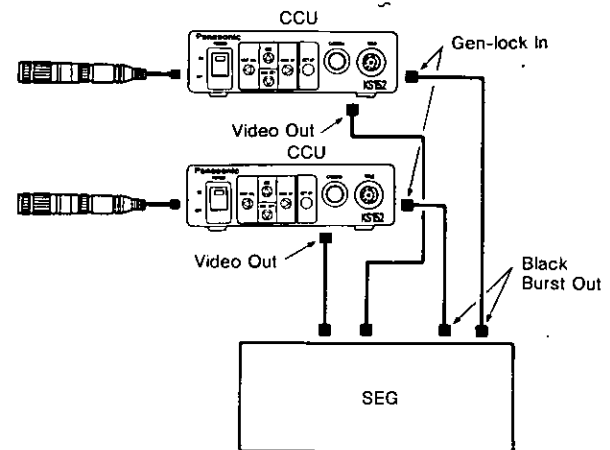



## INSTALLATIONS

- Camera Head

Camera head can be installed on the ceiling, wall etc. using the threaded 1/4" -20 UNC screw hole of the Tripod Attachment (Standard Accessory).

1. Loosen the screw of camera holding band until it is stopped and insert to the camera head.

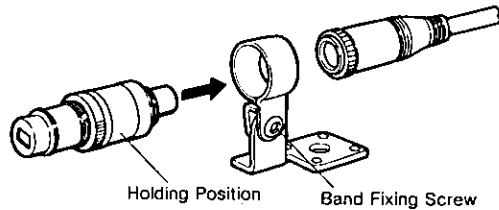

2. Loosen the screw of camera holding band.

**Note :**

Do not remove the screw from the band.

3. Adjust the tilt angle and rotation of camera head and secure the camera with holding band.

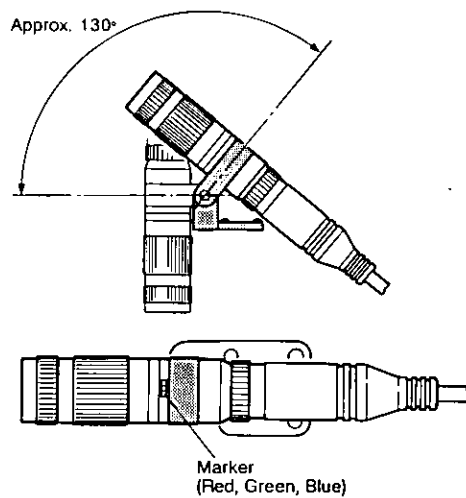

4. Mount the tripod attachment onto the tripod or other mounting bracket (sold separately).

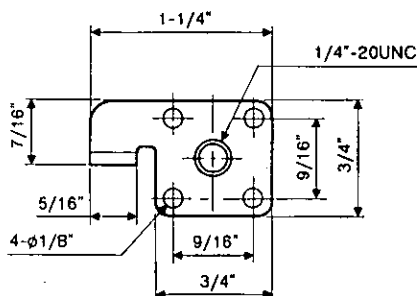

**Caution :**

If the optional C-mount lens size exceeds 2" (50.8 mm) in diameter, 2-3/4" (70 mm) in length and 0.66 lbs (300 g) in weight, both the camera and lens should be secured.

# SETUP PROCEDURE

This camera has two type of user setup procedures using on-screen character display. One is a Direct Mode and the other is Setup Menu Mode.

## 1. DIRECT MODE

Four kind of functions (AGC, GAIN UP, WHT BAL, and AWC SET) can be operated by simply pressing these buttons. The Direct Mode has a priority to the Setup Menu Mode in setting up the functions. The Direct Mode overrides the value of the Setup Menu Mode.

### 1-1. Auto Gain Control (AGC)

The current status of the AGC is displayed on the video monitor for 2 seconds by pressing the AGC Selection Button (4). The status changes by pressing this button.

→ AGC OFF → AGC LOW → AGC MID → AGC HI →

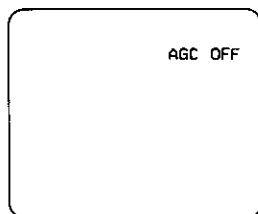

Fig. 1

**Note :**

When one of the AGC LOW/AGC MID/AGC HI is selected, the status of the GAIN should be off.

### 1-2. Gain Up (GAIN UP)

The current status of the GAIN UP is displayed on the video monitor for 2 seconds by pressing the Gain Selection Button (6). The status changes by pressing this button.

→ GAIN OFF → GAIN LOW → GAIN MID → GAIN HI →

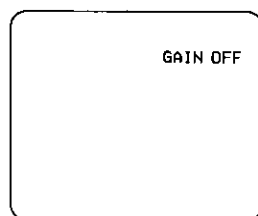

Fig. 2

**Notes :**

1. When one of the GAIN LOW/GAIN MID/GAIN HI is selected, the status of the AGC should be off.
2. The Gain Up Operation is disabled under ELC ON mode. See page 18 for ELC mode operation.

### 1-3. White Balance (WHT BAL)

The current status of the WHT BAL is displayed on the video monitor for 2 seconds by pressing the White Balance Mode Selection Button (3). The status changes by pressing this button.

→ AWC (PUSH SW) → ATW → MANU →

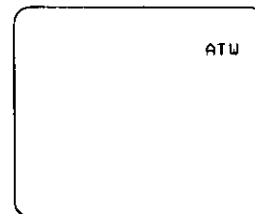

Fig. 3

**Notes :**

1. When the MANU is selected, the White Balance can be made in the Setup Menu Mode. See page 17 for White Balance Setting.
2. When the AWC (PUSH SW) is selected, press the Down Button (AWC SET) to setup the white balance. When the white balance is completed, AWC (PUSH SW) changes to AWC.

### 1-4. Auto White Balance Control (AWC SET)

The setting up of the white balance will be completed by pressing this button. If the white balance can not be completed, "AWC" blinks for 3 seconds and disappears.

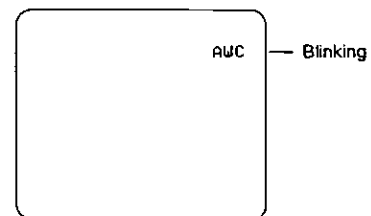

Fig. 4

**Note :**

If the camera has been set at ATW or MANU mode, ATW or MANU character will be displayed for 2 seconds when the AWC SET Button (5) is pressed. If some other button is selected during this 2 seconds, the camera proceed to the new function.

### 1-5. Setup Mode (SET UP)

When the Setup Mode Button (7) (SET UP) is pressed for more than one second, the Setup Menu is displayed on the video monitor and the camera enters to the Setup Menu Mode.

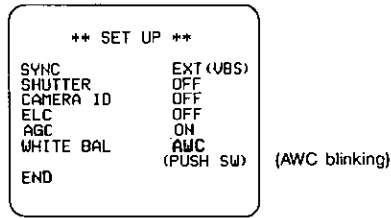

Fig. 5

## 2. SETUP MENU

This camera utilizes various user setup menu using on-screen character display.

This setup menu is structured as a tree-type menu as shown in Fig. 6.

This menu is described in the following section 4. "SETUP MENU DESCRIPTION" in detail.

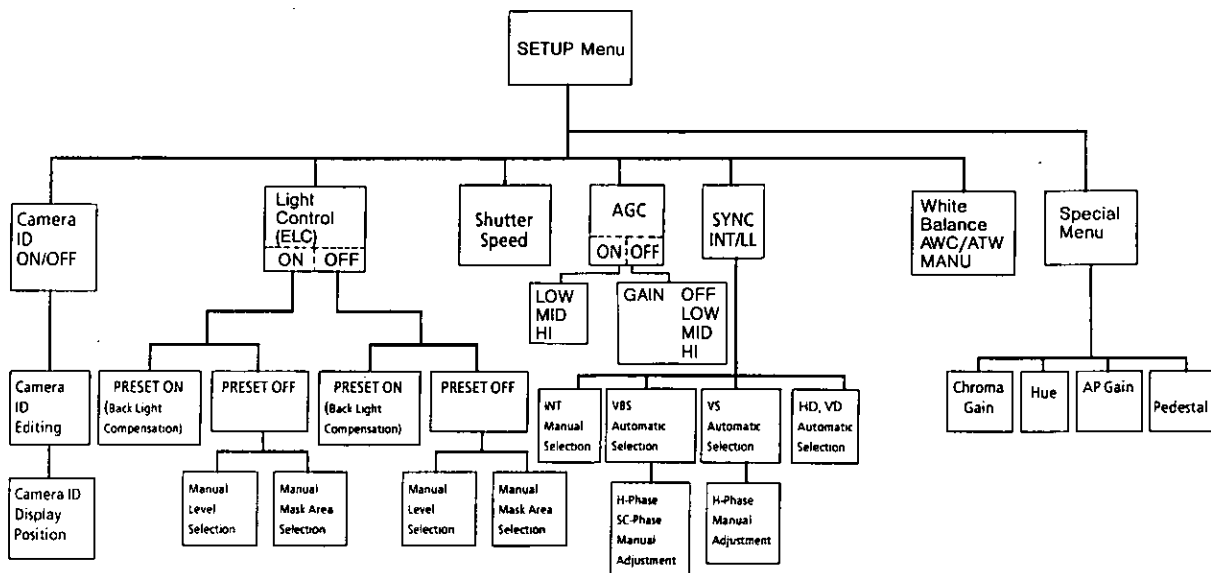

Fig. 6

All setup operations are performed by the following buttons on the front panel:

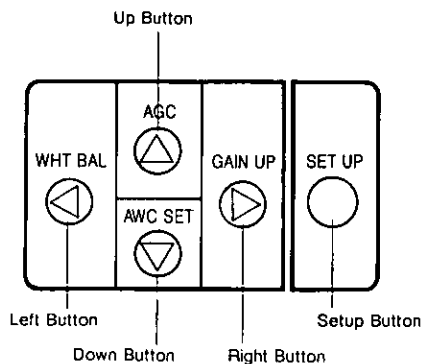

Fig. 7

Up Button (AGC):

The cursor moves upwards.

Down Button (AWC SET):

The cursor moves downwards.

Right Button (GAIN UP):

The cursor moves right. The mode is selected by this button. The adjustment of certain levels can be made by this button.

Left Button (WHT BAL):

The cursor moves left. The mode is selected by this button. The adjustment of certain levels can be made by this button.

Setup Mode Button (SET UP):

The mode is set by this button. The menu is changed by this button.

### 3. SETUP ORDER

When the camera setup is required, proceed it according to the following steps.

- (1) Display the "SETUP" menu. (See page 10 for description and page 12 for procedure.)
- (2) Camera Identification setting. (See page 10 for description and page 13 for procedure.)
- (3) Electronic Light Control setting. (See page 12 for description and page 14 for procedure.)
- (4) Shutter speed setting. (See page 11 for description and page 15 for procedure.)
- (5) Gain Control setting. (See page 11 for description and page 15 for procedure.)
- (6) Synchronization setting. (See page 11 for description and page 15 for procedure.)
- (7) White Balance setting. (See page 12 for description and page 17 for procedure.)
- (8) Backlight Compensation setting. (See page 10 for description and page 18 for procedure.)
- (9) Special Menu setting. (See page 12 for description and page 21 for procedure.)

### 4. SETUP MENU DESCRIPTION

#### 4-1. Camera Identification (CAMERA ID)

Up to 16 of alphabetic/numerical characters for camera identification characters can be displayed on the bottom line of the picture.

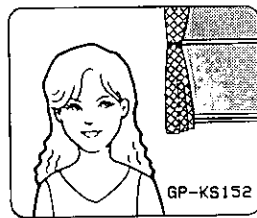

Fig. 8

The ID display ON or OFF can be chosen by the primary setup menu and the editing of displayed characters is made available in the secondly submenu.

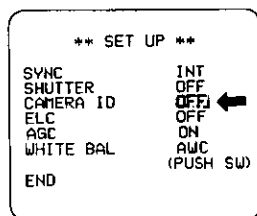

Fig. 9

**Note:**

Refer to the SETUP OPERATION section for detailed procedure.

#### 4-2. Backlight Compensation (BACKLIGHT COMP)

With conventional cameras, strong background lighting such as a spotlight, interferes with the clarity of important scene objects, making them appear dark. This camera is equipped with a backlight compensation mode to overcome this problem.

As shown in the Fig. 6 SETUP MENU TREE, the factory setup mode of backlight compensation (PRESET ON) and field (manual) masking area and video output level setup (PRESET OFF) (MANUAL SET) modes are available.

- **Factory Setup Mode (PRESET ON)**

In normal use the important object in a scene is placed in the center of the monitor's screen. In the factory setup mode, more photometric weight is given to the center of the screen (where the important object is located) than is given to the edge of the picture (where a bright backlight would most likely be located). In this mode, even though the backlight may vary, the object at the center of the screen can still be clearly seen.

**Notes:**

- The masking area and the video output level are factory setup in this mode.
- Refer to the SETUP OPERATION section for detailed procedure.

<Conventional Camera>

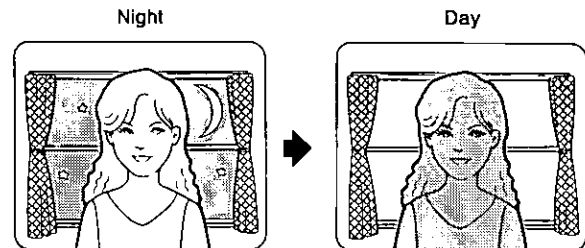

<GP-KS152 Preset ON>

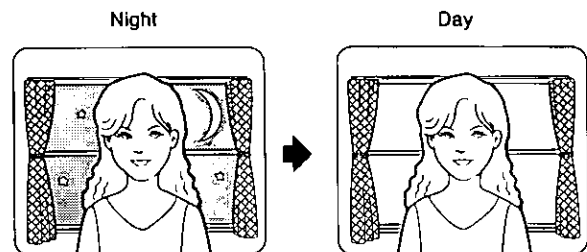

Fig. 10

- **Field Setup Mode (PRESET OFF)**

This mode is effective in conditions where the important object in the scene is not located in the center of the picture and when a bright light source is located near the center of the screen. A conventional camera cannot cope with these situations.

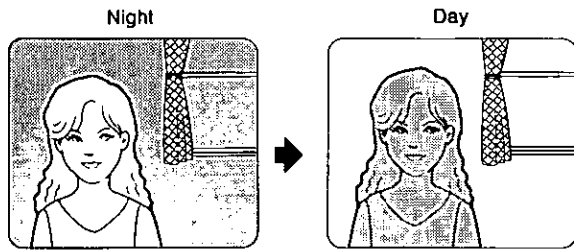

Fig. 11

However, by using the GP-KS152 in the preset "OFF" mode, it is possible to compensate for difficult lighting conditions. In this mode, the picture is divided into 25 zones for mask areas. It is possible to mask (or tell the camera to ignore) any bright light sources in those mask areas that might interfere with picture clarity.

For example, a strong spotlight in the background might cause the lens iris to close down so much that all other objects in the scene appear dark. With backlight compensation, it is possible to mask out the spotlight and increase the rest of the scene's brightness as shown below.

In addition to the field mask area setup, the overall video output level can be adjusted by using the level adjustment (LEVEL) in the preset "OFF" mode.

<GP-KS152 Masked>

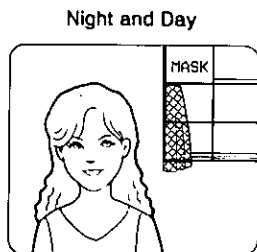

Fig. 12

**Notes:**

- The result of field setup of the mask area and level adjustment is fed back (effected) to the exposure time control of the CCD image sensor at the ELC mode.
- Refer to the SETUP OPERATION section for detailed procedure.

**4-3. Shutter Speed (SHUTTER)**

The electronic shutter speed can be select among the 1/60 second (OFF) and 1/100 - 1/10000 second.

**Note:**

Refer to the SETUP OPERATION section for detailed procedure.

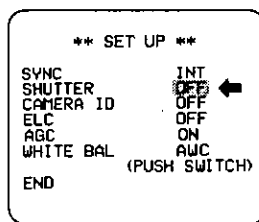
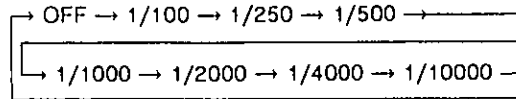

Fig. 13



**4-4. Gain Control (AGC)**

The gain control can be selected between the automatic gain control (AGC ON) and manual gain control (AGC OFF) by this menu.

**Note:**

Refer to the SETUP OPERATION section for detailed procedure.

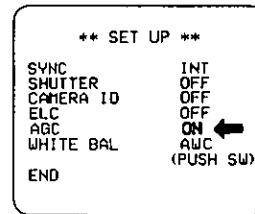

Fig. 14

**4-5. Synchronization (SYNC)**

The camera sync can be chosen between the internal sync (INT) and the external sync mode by this menu. This camera accepts a composite color video signal (VBS) or composite B/W (black and white) video signal (VS) for the Gen-lock input signal to be supplied to Gen-lock Input Connector (11). The sync mode selection in this case is performed automatically.

This camera also accepts the vertical drive (VD) signal and the horizontal drive (HD) signal as for the external synchronization.

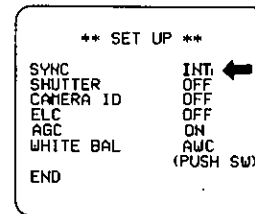

Fig. 15

**Important Notice:**

The priority of sync mode is as follows.

1. Color Composite Video Signal (VBS)
2. B/W Composite Video Sync Signal (VS)
3. HD/VD Signal
4. VD Signal
5. Internal Sync (INT)

**Note:**

The sync mode selection among above modes is made according to priority. Refer to the SETUP OPERATION section for detailed procedure.

#### 4-6. White Balance (WHITE BAL)

A color characteristic of illumination is called color temperature and it is measured in units of Kelvin (°K). The higher color temperature are considered bluish while the lower color temperatures are more reddish. A camera shooting a scene with high color temperature illumination produces a bluish picture. Likewise, it will produce a reddish picture with lower color temperature illumination. Therefore, in order for the camera to reproduce a scene accurately, it needs to be white balanced before shooting.

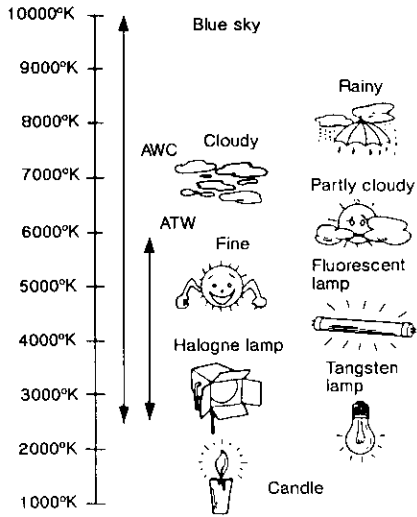

Fig. 16

The white balance control mode can be chosen among the auto-tracing white balance (ATW), the manual white balance control (MANU) and one-touch automatic white balance control (AWC) mode by this menu.

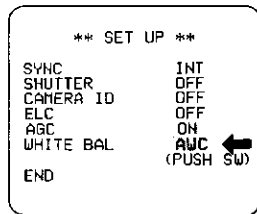

Fig. 17

##### 4-6-1. Auto-Tracing White Balance Mode (ATW)

In the ATW mode the color temperature of the illuminant is continuously monitored and the white balance of the camera is automatically set.

The ATW mode has a range of operation from approximately 2600°K - 6000°K. Beyond this range, use the Automatic White Balance (AWC) mode.

The ATW mode might not produce optimum color rendition in the following conditions.

1. When the scene consists mostly of strongly colored objects or illumination such as a blue sky or during sunset.
2. When the scene is dimly lit.  
In these cases, use the AWC mode.

##### 4-6-2. Automatic White Balance Control Mode (AWC)

In this mode, accurate white balance may be obtained within a range of operation from approximately 2300°K - 10000°K.

**Note:**

Refer to the SETUP OPERATION section for detailed procedure.

##### 4-6-3. Manual White Balance Control Mode (MANU)

In this mode, the white balance can be obtained manually by adjusting R-Gain and B-Gain on-screen menu.

#### 4-7. Special Menu (SPECIAL)

The chroma level, chroma phase (HUE), aperture level and pedestal level of this camera can be adjusted by using this special menu.

**Note:**

Refer to the SETUP OPERATION section for detailed procedure.

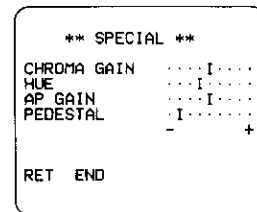

Fig. 18

- 4-8. In the ELC mode, a continuously variable electronic shutter is employed to automatically control the exposure times in the CCD image sensor, according to the incoming light level. With this mode selected, fixed or manual iris lens can be used.

#### 5. SETUP OPERATION

Before entering the Setup menu, remember the ALL RESET operation in order to escape from the confusion of setting up the each item to the factory setup condition as follows.

- (1) Confirm that the normal camera picture is displayed and no setup menu is displayed.
- (2) While pressing both the Left Button (WHT BAL) and Right Button (GAIN UP) together, press the Setup Mode Button (SET UP) for a while in order to reset all adjustments and selections to the factory setup condition.

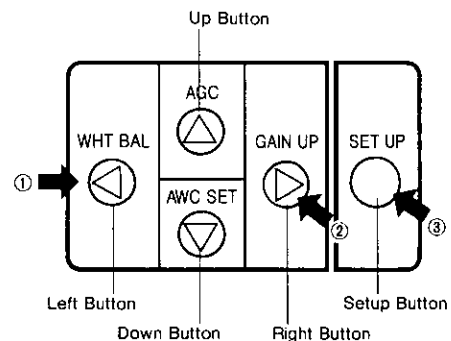

Fig. 19

**Note:**

While the ALL RESET mode is being processed, picture may be disturbed. This phenomenon is normal and indicating the sign of the all reset mode.

**5-1. Entering Setup Menu**

- By pressing the Setup Mode Button (SET UP) for more than 1 second, the "SET UP" menu is displayed on the monitor screen as shown in Fig. 20.

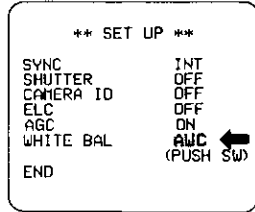

Fig. 20

- By observing this menu, you can check the current conditions. Refer to the following sections for details of each item.
- After confirming current conditions and further resetting of each item is not required, move the cursor to the "END" position on the left bottom line and press the Setup Mode Button (SET UP) to return to the normal camera picture mode.

**Notes:**

- Whenever completing the setup menu, move the cursor to the "END" position and press the Setup Mode Button (SET UP) and confirm that the "SETUP MENU" disappears from the screen in order to ensure the latest data to be stored in the memory. In addition, do not connect or disconnect the Gen-lock input signal during setting the "SETUP MENU" as this could cause a reset of set data.
- When no key is pressed for 5 minutes while any of SETUP MENU is being displayed, the SETUP MENU is automatically ended and returns to the normal picture.

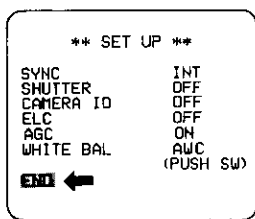

Fig. 21

- When the Special Menu is needed to be adjusted, move the cursor to the "END" position and press both the Left Button (WHT BAL) and Right Button (GAIN UP) together for approximately 2 seconds to display the Special Menu. (Refer to the 7. SPECIAL MENU on page 21.)

**Important Notice:**

When the cursor is moved to the next position (next item) after changing the data (ex. ON → OFF), the latest data is written on the memory (Electronic Erasable Programmable Read Only Memory (EEPROM)) and it remains until the further data write is made even if the camera power is switched off.

**5-2. Camera Identification (CAMERA ID) Setting**

- Move the cursor to the "CAMERA ID" mode position, and select either "ON" (Camera Identification character is displayed) or "OFF" mode by using either the Left Button (WHT BAL) or Right Button (GAIN UP).

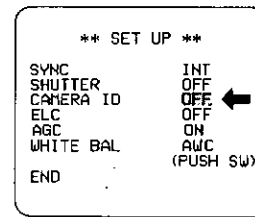

Fig. 22

- Move the cursor to the next item to write the new data into the memory.
- When the camera identification character needs editing, perform the following steps by using the submenu of Camera Identification.
- Move the cursor to the "CAMERA ID" mode position and press the Setup Mode Button (SET UP) to display the Character Editing menu as shown in Fig. 23.

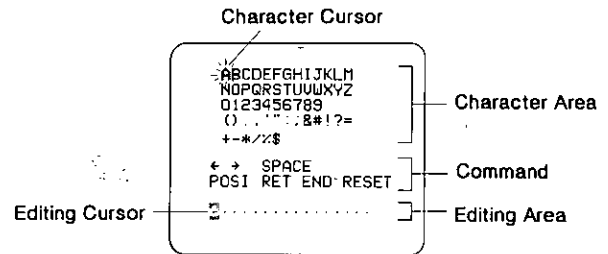

Fig. 23

- The character cursor on the letter "A" and the editing cursor on the left end of the editing area starts blinking.
- Move the character cursor to the desired letter by using the Up Button (AGC), Down Button (AWC SET), Left Button (WHT BAL) and Right Button (GAIN UP) and press the Setup Mode Button (SET UP). The selected letter is written on the editing cursor. (The blinking Editing Cursor moves to right automatically at this moment.)
- Repeat this procedure until the character editing has been completed.

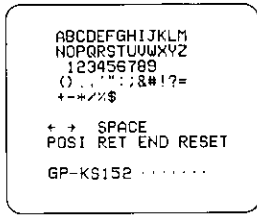

Fig. 24

- When the position of the editing cursor is to be shifted on the editing area, move the character cursor to the "←" or "→" and press the Setup Mode Button (SET UP). This function is used to move the editing position or correct an individual character.

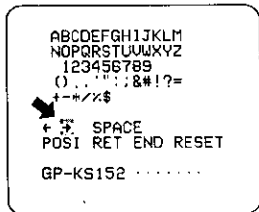

Fig. 25

- When a blank space is needed, move the character cursor to the "SPACE" position and press the Setup Mode Button (SET UP). The blank space is inserted into the cursor position on the editing area.

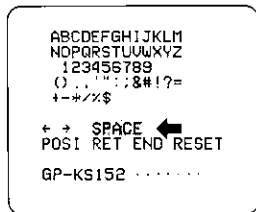

Fig. 26

- When the all characters in the editing area are to be erased, move the character cursor to the "RESET" position and press the Setup Mode Button (SET UP).

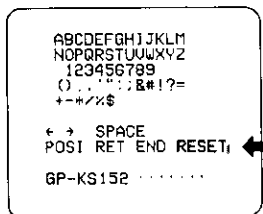

Fig. 27

- After completing the editing of the Camera Identification characters, the display position of the Camera Identification character on the monitor screen can be set as follows.
- Move the character cursor to the "POSI" position and press the Setup Mode Button (SET UP) to display the ID position menu as shown Fig. 28 and the characters of the camera ID starts blinking to identify the positioning menu for you.



Fig. 28

- The display position of the camera ID on the monitor screen can be changed anywhere on the entire screen by using the Up Button (AGC), Down Button (AWC SET), Left Button (WHT BAL) and Right Button (GAIN UP).

**Notes:**

- The position moving of the camera ID stops at the edges of the monitor screen.
- The camera ID moves faster when any of the Up Button (AGC), Down Button (AWC SET), Left Button (WHT BAL) and Right Button (GAIN UP) is kept pressed for more than 0.5 seconds.

- After completing the positioning of the camera ID, press the Setup Mode Button (SET UP) to return to the Character Editing menu as shown in Fig. 23.
- To return to the normal camera picture mode, move the character cursor to the "END" position and press the Setup Mode Button (SET UP).
- To return to the Setup menu for setting other items, move the character cursor to the "RET" position and press the Setup Mode Button (SET UP).

**5-3. Light Control Setting (ELC)**

- Display the Setup menu as shown in Fig. 20.
- Move the cursor to the "ELC" mode position and select either the "ON" or "OFF" mode by using the Left Button (WHT BAL) or Right Button (GAIN UP).

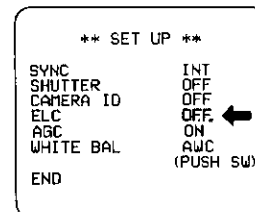

Fig. 29



**Caution :**

The backlight compensation setting allocated under this menu is described in the section 6 and this setting should be done after installing the camera to the site and observing the actual site picture.

**5-4. Shutter Speed Setting (SHUTTER)**

- Display the Setup menu as shown in Fig. 20.
- Move the cursor to the SHUTTER mode position and select the electronic shutter speed by pressing the Left Button (WHT BAL) and the Right Button (GAIN UP).

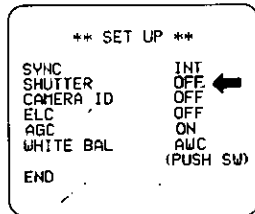

Fig. 30

The following electronic shutter speed is available.

```

  OFF (1/60) → 1/100 → 1/250 → 1/500 →
  1/1000 → 1/2000 → 1/4000 → 1/10000 →
  
```

**5-5. Gain Control Setting (AGC ON/OFF)**

- Display the Setup menu as shown in Fig. 20.
- Move the cursor to the AGC mode position and select either ON or OFF mode by using the Left Button (WHT BAL) and Right Button (GAIN UP).
- When the ON mode is selected and the Setup Mode Button (SET UP) is pressed, the "HI" is displayed as shown in Fig. 31.

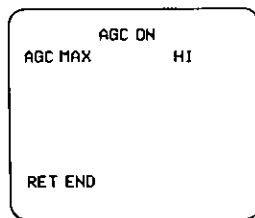

Fig. 31

- Press the Left Button (WHT BAL) or the Right Button (GAIN UP) to select the AGC level. The level changes as follows.

```

  → HI → LOW → MID →
  
```

**Notes :**

LOW is approximately +6 dB  
 MID is approximately +9 dB  
 HI is approximately +12 dB

- If you want to return to the normal picture mode, move the cursor to the END position. Then press the Setup Mode Button (SET UP). However, if you want to set up of the AGC OFF mode, proceed the following procedures.
- Move the cursor to RET position and press the Setup Mode Button (SET UP) to display the Setup Menu.
- AGC ON is blinking in the Setup Menu. Change the ON to OFF by pressing the Left Button (WHT BAL) or the Right Button (GAIN UP). Then press the Setup Mode Button (SET UP) to display AGC OFF menu as shown in Fig. 32.

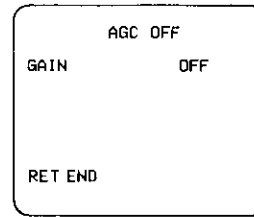

Fig. 32

- Press the Left Button (WHT BAL) or the Right Button (GAIN UP) to select the Gain. The Gain changes as follows.

```

  → OFF → LOW → MID → HI →
  
```

**5-6. Synchronization Setting (SYNC)**

- Display the Setup menu as shown in Fig. 20.
- Move the cursor to the SYNC mode position.

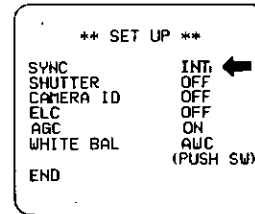

Fig. 33

**Important Notice :**

1. The priority of sync mode is as follows.
  1. Color Composite Video Signal (VBS)
  2. B/W Composite Video Sync Signal (VS)
  3. HD/VD Signal
  4. VD Signal
  5. Internal Sync (INT)
2. When the internal sync mode is to be used, select the INT position and no gen-lock input signal should be supplied to the Gen-lock Input Connector (11) on the rear panel.
3. When the VBS or VS gen-lock mode is to be used, and supply the gen-lock input signal to the Gen-lock Input Connector (11) on the rear panel.

4. The VBS gen-lock mode has a submenu of the horizontal and subcarrier phase adjustments as shown in the following section 5-6-1. When the cable length of video output signal or gen-lock input signal is changed, the horizontal and subcarrier phase must be readjusted.
5. The VS gen-lock mode has a submenu of the horizontal phase adjustment as shown in the following section 5-6-2. When the cable length of video output signal or gen-lock input signal is changed, the horizontal phase must be readjusted.
6. When the HD/VD or VD is to be used, supply them to the HD/GEN-LOCK connector and (or) VD connector on the rear panel.

#### 5-6-1. VBS Gen-lock Mode (EXT(VBS))

- Connect the coaxial cable of the blackburst or composite color video signal to the Gen-lock Input Connector (11) and confirm that the "INT" position has been changed into the "EXT(VBS)" indication.

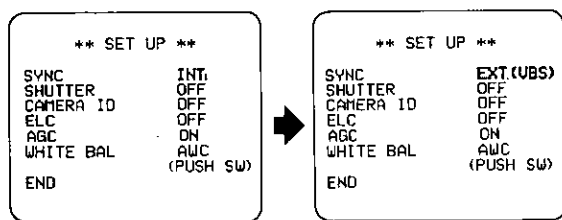

Fig. 34

#### CAUTION:

The gen-lock input signal should be met with the EIA RS-170A specification and should not contain jitter such as VTR playback signal as it could cause a synchronization error.

- After confirming that the cursor is on the "EXT(VBS)" position, press the Setup Mode Button (SET UP) on the front panel and following phase adjustment menu is then displayed on the monitor.

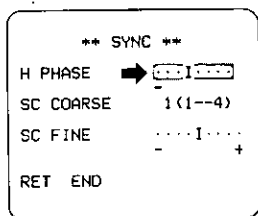

Fig. 35

- Move the cursor to the "H PHASE" mode position. The cursor "I" starts blinking.
- Connect the camera video output signal and the gen-lock input signal to a dual-trace oscilloscope.
- Set the oscilloscope to the horizontal rate and expand the horizontal sync portion on the oscilloscope.
- Adjust the horizontal phase by using the Left Button (WHT BAL) or Right Button (GAIN UP). The cursor "I" moves left or right. The adjustable range is 0 - 2.5  $\mu$ sec.

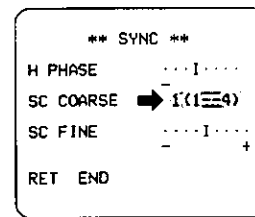

Fig. 36

- Move the cursor to the "SC COARSE" mode position for subcarrier phase adjustment. The cursor starts blinking.
- Press the Left Button (WHT BAL) or Right Button (GAIN UP) so that the color of the Effect Output video signal (Program Output video signal) of the Special Effects Generator (SEG) becomes the closest color of the original objects. (The SC coarse adjustment can be made for every 90 degrees (4 steps) by using the Left Button (WHT BAL) or Right Button (GAIN UP).)

#### Note:

After the fourth step, it returns to the first step.

- 1 (1 - - 4): 0 degree
- 2 (1 - - 4): 90 degrees
- 3 (1 - - 4): 180 degrees
- 4 (1 - - 4): 270 degrees

- Move the cursor to the "SC FINE" mode position. The cursor starts blinking.
- Press the Left Button (WHT BAL) or Right Button (GAIN UP) so that the color of the Effect Output video signal (Program Output video signal) of the Special Effects Generator (SEG) becomes the closest color of the original objects. (The fine adjustment can be made for up to 90 degrees by using the Left Button (WHT BAL) or Right Button (GAIN UP).)

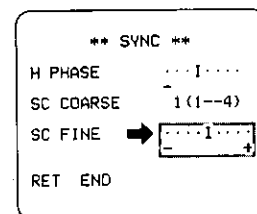

Fig. 37

#### Notes:

1. When the cursor "I" reaches to the end of "+" position, the cursor "I" jumps to the "-" position. At the same time, the step number of the SC COARSE mode increases one step to make enable a continuous adjustment. The reverse operation takes place when the cursor "I" reaches to the end of "-" position.

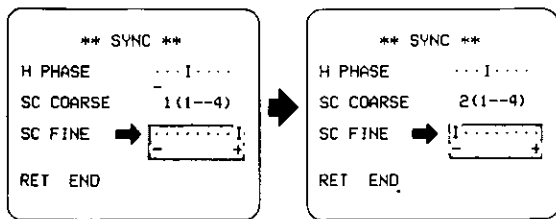

Fig. 38

- When the Left Button (WHT BAL) or Right Button (GAIN UP) is kept pressed for more than one second, the cursor "I" moves quickly.
- For more accurate adjustment, supply both the original camera video output signal and the Effect Output video signal (Program Output video signal) of the Special Effects Generator (SEG) to the vectorscope and compare the chroma phase for both signals.
- When both the Left Button (WHT BAL) and the Right Button (GAIN UP) are pressed simultaneously, the cursor "I" is reset to the factory setup position.

#### 5-6-2. VS Gen-lock Mode (EXT(VS))

- Connect the coaxial cable of the composite sync or composite black-and-white video signal to the Gen-lock Input Connector (11) and confirm that the "INT" position has been changed into the "EXT(VS)" indication.

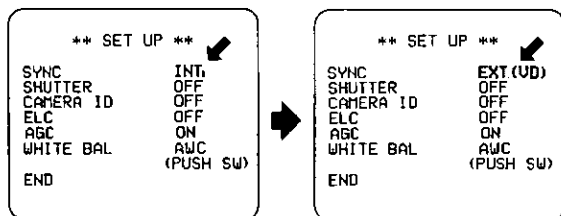

Fig. 39

#### CAUTION:

The gen-lock input signal should be met with the EIA RS-170 specification and should not contain jitter such as VTR playback signal as it could cause a synchronization error.

- After confirming that the cursor is on the "EXT(VS)" position, press the Setup Mode Button (SET UP) on the front panel and following phase adjustment menu is then displayed on the monitor.

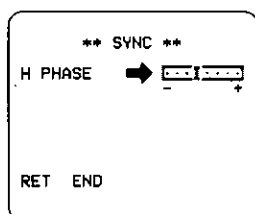

Fig. 40

- Connect the camera video output signal and the gen-lock input signal to a dual-trace oscilloscope.
- Set the oscilloscope to the horizontal rate and expand the horizontal sync portion on the oscilloscope.
- Adjust the horizontal phase by using the Left Button (WHT BAL) or Right Button (GAIN UP). The cursor "I" moves left or right. The adjustable range is 0 - 2.5  $\mu$ sec.

#### 5-6-3. External HD/VD Mode (HD/VD)

- Connect the coaxial cable of the external HD and VD signal to the HD/GEN-LOCK connector and VD connector respectively and confirm that the "INT" position changes to the EXT (H/V) indication.

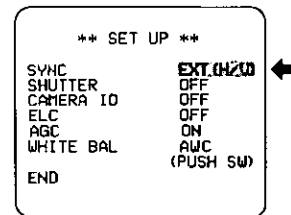

Fig. 41

No more setting up or adjustment is required.

#### 5-6-4. External VD Mode (VD)

- Connect the coaxial cable of the external VD signal to the VD connector and confirm that the "INT" position changes to the EXT (VD) indication.

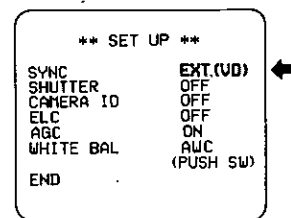

Fig. 42

No more setting up or adjustment is required.

#### 5-7. White Balance Setting (WHITE BAL)

##### 5-7-1. Auto-Tracing White Balance Mode (ATW)

- Display the Setup menu as shown in Fig. 20.
- Move the cursor to the "WHITE BAL" mode by pressing the Left Button (WHT BAL) and the Right Button (GAIN UP).

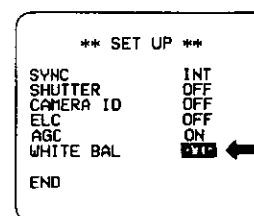

Fig. 43

No more setting up or adjustment is required.

### 5-7-2. Automatic White Balance Control Mode (AWC)

- Move the cursor to the "WHITE BAL" mode position and select the "AWC" mode by pressing the Left Button (WHT BAL) or Right Button (GAIN UP). "(PUSH SW)" is now displayed.

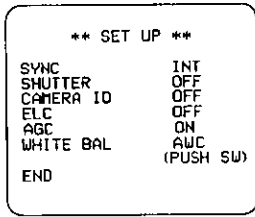

Fig. 44

- Press the Setup Mode Button (SET UP) to setup the white balance. The "(PUSH SW)" display starts blinking to indicate that the white balance is being set.

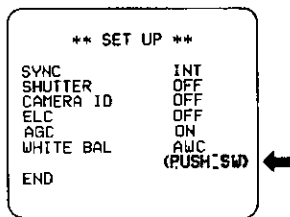

Fig. 45

- When the white balance setting is completed, the blinking "(PUSH SW)" stops.

### 5-7-3. Manual White Balance Mode (MANU)

- Move the cursor to the "WHITE BAL" mode position and select the "MANU" mode by pressing the Left Button (WHT BAL) or Right Button (GAIN UP). "MANU" is now displayed.

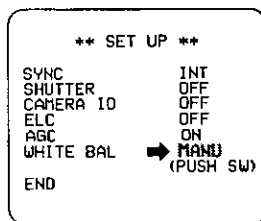

Fig. 46

- Press the Setup Button (SET UP) to display the following gain adjustment menu on the screen.

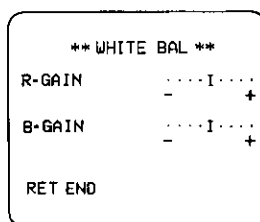

Fig. 47

- The cursor on the "R-GAIN" position is blinking.
- Keep pressing the Left Button (WHT BAL) or the Right Button (GAIN UP) to obtain an optimum Red gain. The cursor "I" moves to right or left.
- Move the cursor to the "B-GAIN" position.
- Keep pressing the Left Button (WHT BAL) or the Right Button (GAIN UP) to obtain an optimum Blue gain. The cursor "I" moves to right or left.

## 6. BACKLIGHT COMPENSATION (BACKLIGHT COMP)

### 6-1. ELC OFF Mode

- Confirm that the ELC mode is selected as follows.
- Display the Setup menu as shown in Fig. 20.
- Move the cursor to the "ELC" mode position and select the "OFF" mode by using the Left Button (WHT BAL) or Right Button (GAIN UP).

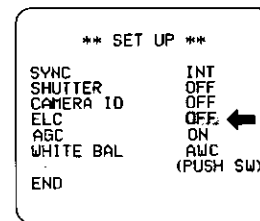

Fig. 48

- Press the Setup Mode Button (SET UP) to proceed to the Backlight compensation menu as shown in Fig. 49.

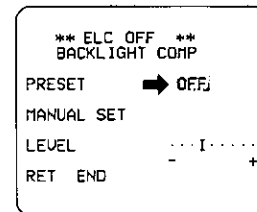

Fig. 49

### 6-1-1. ELC OFF Mode with Preset Mode (PRESET ON)

- Move the cursor to the "PRESET" mode position and select the "ON" mode by using the Left Button (WHT BAL) or Right Button (GAIN UP). The preset mode menu is displayed on the monitor screen as shown in Fig. 50.

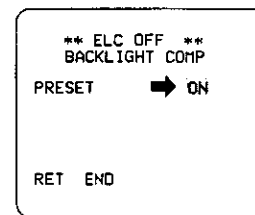

Fig. 50

- Move the cursor to "RET" position by using the Up Button (AGC) or Down Button (AWC SET) and press the Setup Mode Button (SET UP) to return to the Setup menu.

**Note:**

Move the cursor to the "END" position and press the Setup Mode Button (SET UP) to return to the normal camera picture mode.

**6-1-2. ELC OFF Mode with Field Setup Mode (PRESET OFF)**

- Move the cursor to the "PRESET" mode position and select the "OFF" mode by using the Left Button (WHT BAL) and Right Button (GAIN UP).
- The field setup menu is displayed on the monitor screen as shown in Fig. 51.

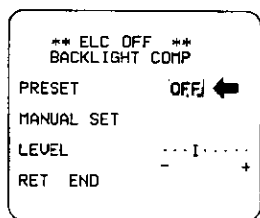

Fig. 51

- Move the cursor to the "MANUAL SET" mode position and press the Setup Mode Button (SET UP). The 25 Mask Areas appears on the monitor screen as shown in Fig. 52. The left top area starts blinking as a cursor.

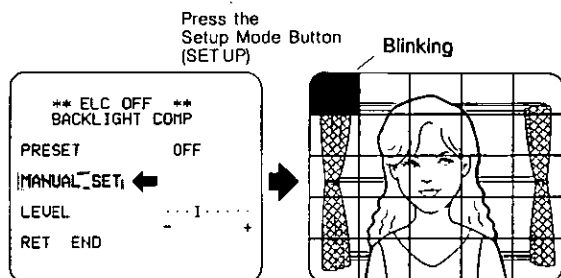

Fig. 52

- To mask this area, press the Setup Mode Button (SET UP). The word "MASK" appears in this area as shown in Fig. 53.

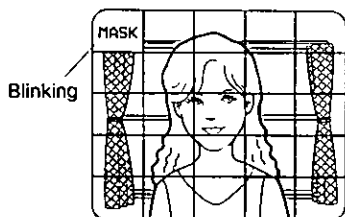

Fig. 53

- To mask other areas, move the cursor to the desired area by using the Up Button (AGC), Down Button (AWC SET), Left Button (WHT BAL) or Right Button (GAIN UP). The previous masked area then stops blinking and turns to white as shown in Fig. 54.

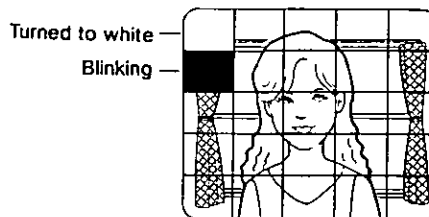

Fig. 54

- When the cursor is moved to the area where has already been masked before, the word "MASK" appears.
- Press the Setup Mode Button (SET UP) when this masking is to be canceled.
- After masking is completed, press the Setup Mode Button (SET UP) for more than 2 seconds and the 25 Mask Areas on the monitor screen disappears and the field setup menu shown in Fig. 51 is then displayed.
- When the video output level (picture contrast) is to be changed, move the cursor to the "LEVEL" mode position and press the Left Button (WHT BAL) and Right Button (GAIN UP). The cursor "I" moves right or left to change the video output level.

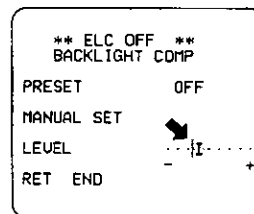

Fig. 55

- Move the cursor to "RET" position by using the Up Button (AGC) or Down Button (AWC SET) and press the Setup Mode Button (SET UP) to return to the Setup menu.

**Note:**

Move the cursor to the "END" position and press the Setup Mode Button (SET UP) to return to the normal camera picture mode.

**6-2. ELC ON Mode**

- Confirm that the ELC mode is selected as follows.
- Display the Setup menu as shown in Fig. 20.
- Move the cursor to the "ELC" mode position and select the "ON" mode by using the Left Button (WHT BAL) or Right Button (GAIN UP).

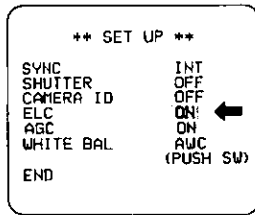

Fig. 56

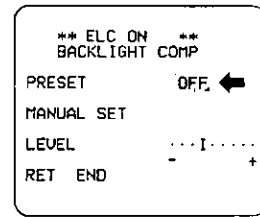

Fig. 59

**Note:**

The Gain Up operation under the Direct Mode is disabled when ELC is ON mode.

- Press the Setup Mode Button (SET UP) to proceed to the Backlight compensation menu as shown in Fig. 57.

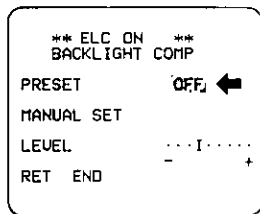

Fig. 57

- Move the cursor to the "MANUAL SET" mode position and press the Setup Mode Button (SET UP). The 25 Mask Areas appears on the monitor screen as shown in Fig. 60. The left top area starts blinking as a cursor.

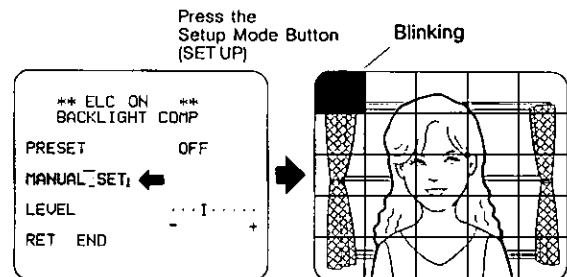

Fig. 60

**6-2-1. ELC ON Mode with Preset Mode (PRESET ON)**

- Move the cursor to the "PRESET" mode position and select the "ON" mode by using the Left Button (WHT BAL) or Right Button (GAIN UP). The preset mode menu is displayed on the monitor screen as shown in Fig. 58.

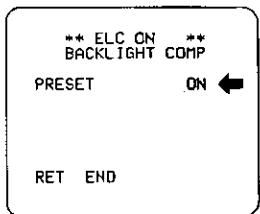

Fig. 58

- To mask this area, press the Setup Mode Button (SET UP). The word "MASK" appears in this area as shown in Fig. 61.

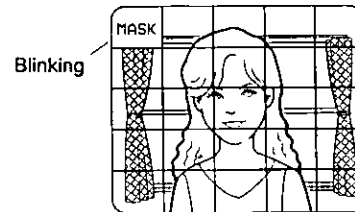

Fig. 61

- Move the cursor to "RET" position by using the Up Button (AGC) or Down Button (AWC SET) and press the Setup Mode Button (SET UP) to return to the Setup menu.

**Note:**

Move the cursor to the "END" position and press the Setup Mode Button (SET UP) to return to the normal camera picture mode.

**6-2-2. ELC ON Mode with Field Setup Mode (PRESET OFF)**

- Move the cursor to the "PRESET" mode position and select the "OFF" mode by using the Left Button (WHT BAL) and Right Button (GAIN UP).
- The field setup menu is displayed on the monitor screen as shown in Fig. 59.

- To mask other areas, move the cursor to the desired area by using the Up Button (AGC), Down Button (AWC SET), Left Button (WHT BAL) or Right Button (GAIN UP). The previous masked area then stops blinking and turns to white as shown in Fig. 62.

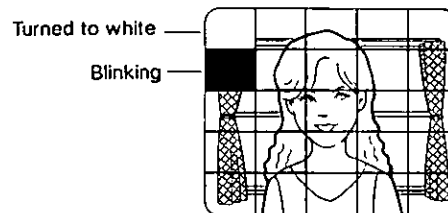

Fig. 62

- When the cursor is moved to the area where has already been masked before, the word "MASK" appears.
- Press the Setup Mode Button (SET UP) when this masking is to be canceled.

- After masking is completed, press the Setup Mode Button (SET UP) for more than 2 seconds and the 25 Mask Areas on the monitor screen disappears and the field setup menu shown in Fig. 59 is then displayed.
- When the video output level (picture contrast) is to be changed, move the cursor to the "LEVEL" mode position and press the Left Button (WHT BAL) and Right Button (GAIN UP) to adjust the exposure time of the CCD image sensor. The cursor "I" moves right (long) or left (short) corresponding to the video output level (exposure time).

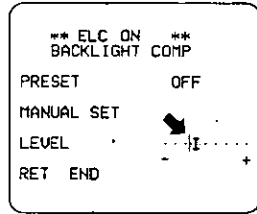

Fig. 63

- Move the cursor to "RET" position by using the Up Button (AGC) or Down Button (AWC SET) and press the Setup Mode Button (SET UP) to return to the Setup menu.

**Note:**

Move the cursor to the "END" position and press the Setup Mode Button (SET UP) to return to the normal camera picture mode.

When a manual iris lens is used with the ELC mode, set the lens iris fully opened in the low lighting condition or adjust the lens iris manually in the normal room lighting condition.

**Remark:**

When the ELC mode is selected, the shutter speed selection is not available.

**7: SPECIAL MENU**

This menu allows for the customer to adjust and set the video signal of the camera to meet the customer's requirement.

- Display the Setup menu as shown in Fig. 20.
- Move the cursor to the "END" position and press both the Left Button (WHT BAL) and the Right Button (GAIN UP) simultaneously for approximately 2 seconds. (The Left Button (WHT BAL) should be pressed first.) The special menu is displayed as shown below

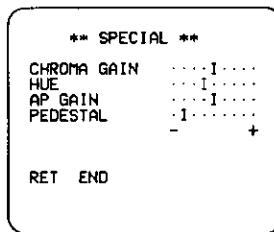

Fig. 64

**7-1. Chroma Level Setting (CHROMA GAIN)**

- Move the cursor to the "CHROMA GAIN" mode position. The cursor "I" starts blinking.

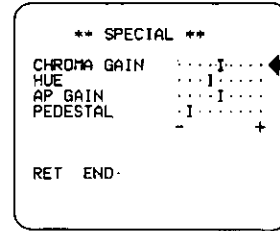

Fig. 65

- While observing the vectorscope or color video monitor, adjust the chroma level by using the Left Button (WHT BAL) and the Right Button (GAIN UP). The cursor "I" moves right or left.

**7-2. Chroma Phase (Hue) Setting (HUE)**

- Move the cursor to the "HUE" mode position. The cursor "I" starts blinking.

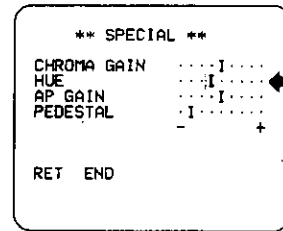

Fig. 66

- While observing the vectorscope or color video monitor, adjust the chroma phase (hue) by using the Left Button (WHT BAL) and the Right Button (GAIN UP). The cursor "I" moves right or left.

**7-3. Aperture Level Setting (AP GAIN)**

- Move the cursor to the "AP GAIN" mode position. The cursor "I" starts blinking.
- While observing the color video monitor, adjust the aperture level by using the Left Button (WHT BAL) and the Right Button (GAIN UP). The cursor "I" moves left (soft) or right (sharp).

**7-4. Pedestal Level Setting (PEDESTAL)**

- Move the cursor to the "PEDESTAL" mode position. The cursor "I" starts blinking.
- While observing the waveform monitor/oscilloscope or color video monitor, adjust the pedestal level (black level) by using the Left Button (WHT BAL) and the Right Button (GAIN UP). The cursor "I" moves left (low, dark) or right (high, bright).

#### Notes:

##### ■ How to reset to factory setup

Any of the above setting plus the ELC level control and phase adjustments can be reset to the factory setup by placing the cursor over the desired mode and then simultaneously pressing both the Left Button (WHT BAL) and the Right Button (GAIN UP) for more than 2 seconds.

## PREVENTION OF BLOOMING AND SMEAR

When the camera is aimed towards spotlights or other bright lights or light reflecting objects, smear or blooming may appear. Therefore the camera should be operated carefully in the vicinity of extremely bright objects to avoid smear or blooming.

If the camera is aimed at the sun or very bright light, such as laser beam, for a long period of time, the CCD image sensor may be burned in and blemishes (white or black dots) appears on the picture.

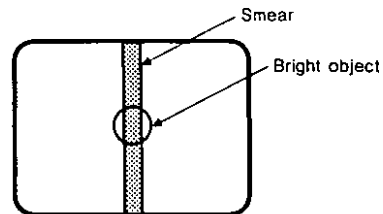

## SPECIFICATIONS

Pick-up Device:	682(H) × 492(V) pixels, 1/2" Interline Transfer CCD
Scanning System:	2 : 1 Interlace
Scanning:	525 Lines/60 Fields/30 Frames
Horizontal:	15.734 KHz
Vertical:	59.94 Hz
Horizontal Resolution:	430 lines
Video Output:	1.0 Vp-p NTSC composite, 75 ohms/BNC connector
Signal to Noise Ratio:	46 dB (AGC OFF)
Electronic Light Control:	Equivalent to continuous variable shutter speed between 1/60 sec. and 1/15,700 sec.
Minimum Illumination:	0.5 footcandle (5 lux) at F1.6 (AGC ON)
White Balance:	AWC/ATW MANU selectable
Back Light Compensation:	Preset On (Factory setup) Preset Off (Manual setup at field) Photometry area is selectable (25 blocks) Signal level is adjustable
Sync. System:	HD/VD/VBS/VS is selectable H-PHASE adjustment in the VBS, VS, Gen-lock SC-PHASE adjustment in VBS Gen-lock mode
Electronic Shutter Speed:	Selectable 1/60 (OFF), 1/100, 1/250, 1/500, 1/1000, 1/2000, 1/4000, 1/10000
AGC Control:	OFF/LOW/MID/HI selectable
Gain Control:	LOW/MID/HI selectable
Ambient Temperature:	14°F - +104°F (-10°C - +40°C)
Power Source:	12V DC, 500mA
Dimensions (Excluding lens):	
Camera Head:	φ2/3" × 2" [φ17 × 52.5mm]
Camera Control Unit:	4-3/4"(W) × 1-7/16"(H) × 6-3/16"(D) [120(W) × 36(H) × 151(D) mm]
Weight (Excluding lens):	
Camera Head:	0.04 lbs. (16g)
Camera Control Unit:	1.6 lbs. (730g)

Weights and dimensions shown are approximate.  
Specifications are subject to change without notice.



## STANDARD ACCESSORIES

Tripod attachment ..... 1pc.  
Lens cleaning tissue paper .....1 sheet

## OPTIONAL ACCESSORIES

Lense: GP-LM3T, GP-LM7R5TA, GP-LP12T,  
GP-LM15T, GP-LM24T

C-mount Adaptor: GP-AD22T

Cable: GP-CA56, GP-CA57

# Panasonic

Communications & Systems Company

Division of Matsushita Electric Corporation of America

## INDUSTRIAL CAMERA DIVISION

### HEADQUARTERS

50 Meadowland Parkway, Secaucus, New Jersey 07094 (201) 392-6674

### WESTERN REGIONAL OFFICE

6550 Katella Ave., Cypress, CA 90630 (714) 373-7270

### MATSUSHITA ELECTRIC OF CANADA LIMITED

5770 Ambler Drive, Mississauga, Ontario, Canada L4W 2T3 (416) 624-5010

### PANASONIC SALES COMPANY

DIVISION OF MATSUSHITA ELECTRIC OF PUERTO RICO, INC.

San Gabriel Industrial Park, 65th Infantry, Ave. KM. 9.5 Carolina, Puerto Rico 00630 (809) 750-4300