



## Artisan Technology Group is your source for quality new and certified-used/pre-owned equipment

- FAST SHIPPING AND DELIVERY
- TENS OF THOUSANDS OF IN-STOCK ITEMS
- EQUIPMENT DEMOS
- HUNDREDS OF MANUFACTURERS SUPPORTED
- LEASING/MONTHLY RENTALS
- ITAR CERTIFIED SECURE ASSET SOLUTIONS

### SERVICE CENTER REPAIRS

Experienced engineers and technicians on staff at our full-service, in-house repair center

### *InstraView*<sup>SM</sup> REMOTE INSPECTION

Remotely inspect equipment before purchasing with our interactive website at [www.instraview.com](http://www.instraview.com) ↗

### WE BUY USED EQUIPMENT

Sell your excess, underutilized, and idle used equipment. We also offer credit for buy-backs and trade-ins. [www.artisanng.com/WeBuyEquipment](http://www.artisanng.com/WeBuyEquipment) ↗

### LOOKING FOR MORE INFORMATION?

Visit us on the web at [www.artisanng.com](http://www.artisanng.com) ↗ for more information on price quotations, drivers, technical specifications, manuals, and documentation

**Contact us:** (888) 88-SOURCE | [sales@artisanng.com](mailto:sales@artisanng.com) | [www.artisanng.com](http://www.artisanng.com)

# Linear Step Motor Systems

## The Advantages of Linear Motor Systems

Linear stepping motors are an excellent solution for positioning applications that require rapid acceleration and high-speed moves with low mass payloads. Mechanical simplicity and precise open-loop operation are additional features of the Compumotor microstepping linear motor systems.

The linear stepping motor is not subject to the same linear velocity and acceleration limitations inherent in systems converting rotary to linear motion. For example, in a leadscrew system, the inertia of the leadscrew frequently exceeds the inertia of the load. Attempting a high-speed move with a low mass payload results in the majority of the motor torque applied to overcoming the leadscrew inertia. As the length of the screw increases, the inertia of the screw increases and the maximum critical speed is reduced. With linear motors, all the force generated by the motor is efficiently applied directly to the load, and length has no effect on system inertia.

### Additional benefits of linear stepping motors

- High Throughput – The motors are capable of speeds to 100 ips and the low mass forcer allows high acceleration.
- Mechanical Simplicity – The need for leadscrews or belts and pulleys is eliminated. The mechanical design is pre-engineered.
- High Reliability – Fewer moving parts and a friction-less air bearing design results in a longer, maintenance-free life.
- Long Travel – Length of travel is limited only by the length of the platen; increasing length causes no degradation in performance.
- Precise Open-Loop Operation – Unidirectional repeatability to 2.5 microns without the added expense of feedback devices.
- Small Work Envelope – A linear motor is usually smaller in all three dimensions than comparable systems where rotary motion is converted to linear.
- Easily-Achieved X-Y Motion – The assembly of X-Y gantry systems is readily accomplished.
- Multiple Motion – More than one forcer can operate on the same platen with overlapping trajectories.

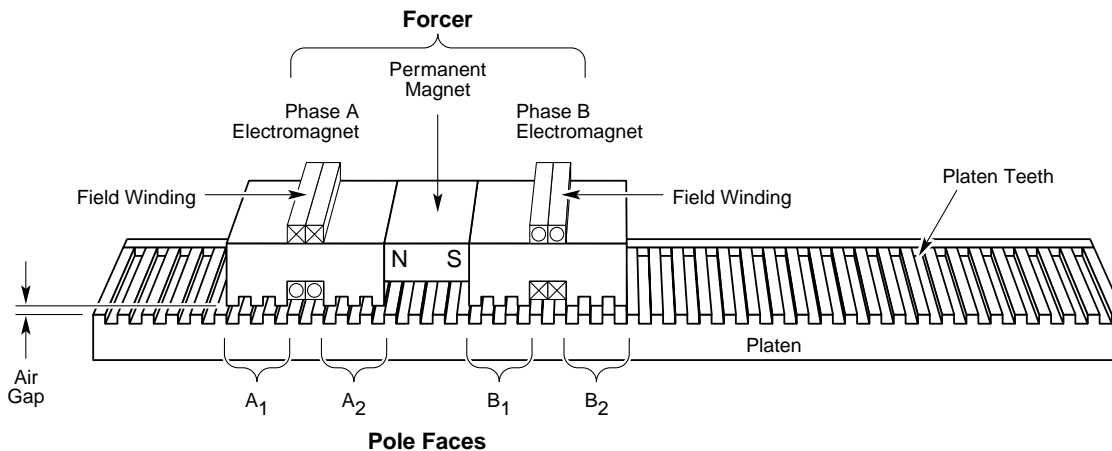

### Construction of a Linear Step Motor

A linear hybrid stepping motor operates on the same electromagnetic principles as a rotary hybrid stepping motor. The moving element is called a forcer. The stationary part is called the platen. The stator or platen is a passive toothed steel bar extending over the desired length of travel. All permanent magnets, electromagnets and bearings are incorporated into the armature or forcer. The forcer moves bi-directional along the platen, assuring discrete locations in response to the state of the currents in the field windings.

### Forcer/Platen Data

Characteristic	L20
Static force lbs (N)	20.0 (89)
Steps/inch	12,500
Repeatability in (mm)	0.0001 (0.0025)
Speed in/sec (m/s)	100 (2.5)
Bearing type	Air
Maximum bearing load lbs (kg)	50 (22.7)
Maximum standard platen lengths in inches (cm)	144 (366)

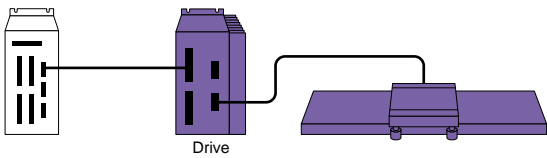

Linear motors offer solutions to a variety of applications and industries. In applications that require high-speed, low-mass moves, the linear-motor is an alternative to conventional rotary-to-linear conversion devices such as leadscrews, rack and pinion, belt drives, pneumatic and hydraulic actuators. Speed, distance, and acceleration are easily programmed in a highly repeatable fashion. Potential industrial and applications include:

- Printed circuit board assembly
- Industrial sewing machines
- Light assembly automation
- Automatic inspection
- Wire harness making
- Automotive manufacturing
- Gauging
- Packaging
- Medical uses
- Parts transfer
- Pick and place
- Laser cut and trim systems
- Flying cutters
- Semiconductor wafer processing
- Water jet cutting
- Print heads
- Fiber optics manufacture
- X-Y plotters

### Flying Cut-to-Length

Linear motors are being used to convert a stop/start process into a continuous flow process on a metal forming machine.

A rotary encoder is used to provide velocity information to an indexer. The indexer accelerates the linear motor to match the speed of the channel. This prevents bending of the channels and binding of the saw. At the same time, the indexer positions the linear motor (saw blade) at the precise spot on the channel to give the desired length. Two more linear motors are used to move the saw and the beam it rides on into and out of the cut.

Once the cut cycle is completed, the linear motor carrying the saw is decelerated and stopped. The direction is reversed and the saw is returned to the starting position at high speed.

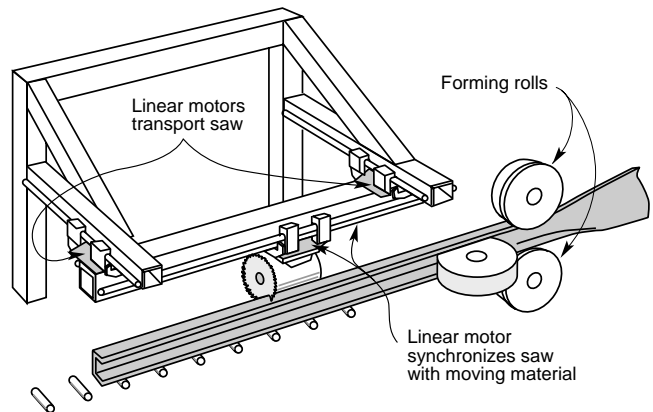

### Coil Winder

A Compumotor ZETA6104 and L20-P96 system act as the traverse element to guide the wire, while an APEX6151 Series servo motor rotates the spindle. Each axis is coordinated by its 6000 controller, preprogrammed to produce a number of different coil types. Precise position control and mechanical simplicity over a long length of travel are provided by the linear motor.

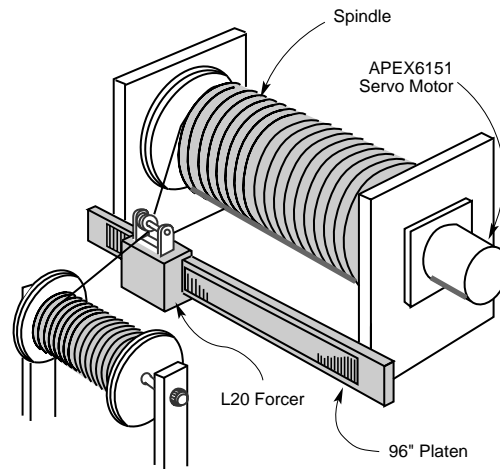

**Forcer only**

L20

**Platen only**

PO-L20-P18

PO-L20-P36

PO-L20-P54

PO-L20-P72

PO-L20-P96

PO-L20-P144

Shorter platen lengths are available for a nominal cutting charge.

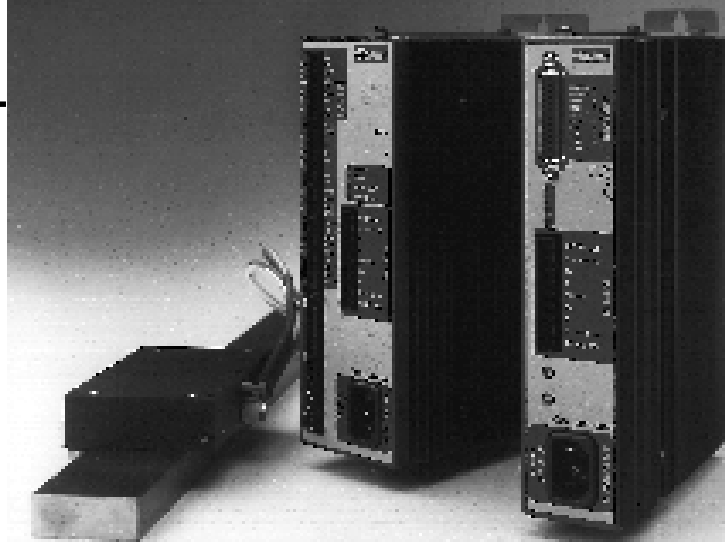

**Specifications**

Parameter	Value
<b>L20 Forcer and Platen</b>	
Static force	20.0 lbs (89 N)
Static normal force between forcer & platen	180.0 lbs (801 N)
Accuracy (worst case)*	±0.0035 in (90 microns)
Repeatability (uni-directional)	±0.0001 in (±2.5 microns)
Hysteresis	0.0005 in (12.5 microns)
Cyclic error (TIR/.01")	±0.0015 in (±37.5 microns)
Platen errors:	
-Cumulative	±0.0001 in/in (0.1 micron/mm)
-Non-cumulative random	±0.0015 in (±37.5 microns)
-Thermal expansion	±0.00000633 in/in/°F (11.4 microns/meter/°C)
Straightness of travel	0.0025 in TIR** (62.5 microns)
Yaw torque	Max: 90 oz-in (7.0 kg-cm)
Pitch torque	Max: 120 oz-in (9.0 kg-cm)
Roll torque	Max: 120 oz-in (9.0 kg-cm)
<b>L20 Forcer</b>	
Type	Two-phase, PM hybrid
Current per phase	2.7A
Operating temperature, force (Ta)	32°F to 104°F (0°C to 40°C)
Maximum forcer case temperature	167°F (75°C)
Operating temperature	32°F to 104°F (0°C to 40°C)
Bearing type	Tops: Air bearing, forced air @ 40 PSI, 20 SCFH. Side: Ball bearing (2), ABEC 3, 8 lb magnetic preload
Air gap (typical)	0.0005 in (12.5 microns)
Maximum forcer load***	Top: 50 lbs (22.7 kgs); Side: 5 lbs (2.27 kgs)
Forcer weight	2 lbs (0.8 kgs)
<b>L20 Platen</b>	
Flatness (assumes flat mounting)	0.010 in TIR free standing on granite base
Surface mounting flatness required for optimum performance	0.00025 in/5 in (6.35 microns/125mm)
Standard lengths	18, 36, 54, 72, 96 or 144 inches (457, 914, 1372, 1828, 2438, 3658 mm)
Weight	6.23 oz/in (67.5 gm/cm)
Platen material	1018 steel
Bottom and side surface plating	Nickel-plated (top is phosphate coated to prevent corrosion)
Tooth pitch	0.040 in (1.016 mm)

\* Platen heating error is not included. See the Technical Data (Section A) for a review of total system accuracy.

\*\* TIR=Total Indicated Reading of difference between maximum and minimum reading.

\*\*\* Top load refers to the vertical force on top of the forcer in the normal horizontal (flat) mounting configuration. Side load refers to the side force (perpendicular to the platen length, pressing on the forcer side bearings) on a forcer when the forcer/platen is mounted vertically.

**C Step Motor Systems**

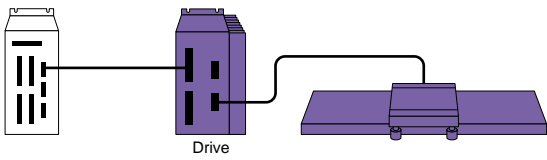

### Performance Curve

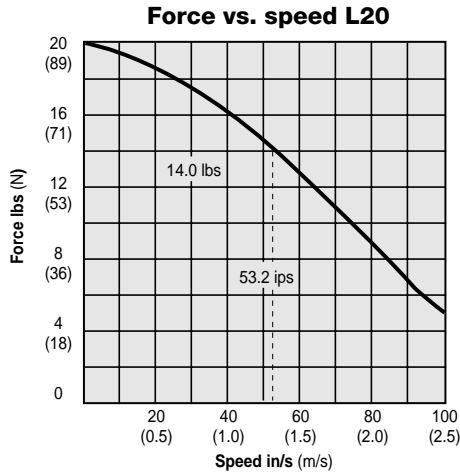

-RFKC Optional Regulator

Coalescing Air Regulator/ Filter Kit

Includes regulator/gauge/filter unit 1/4" quick disconnect coupler, fittings & 30' polyurethane tubing.

### L20 Dimensions (→) denotes millimeters

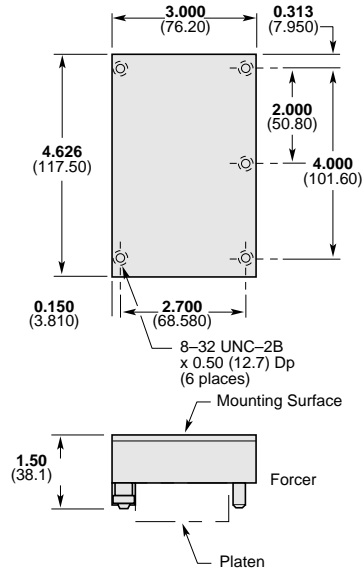
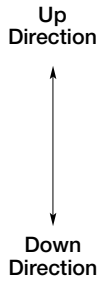

Forcer

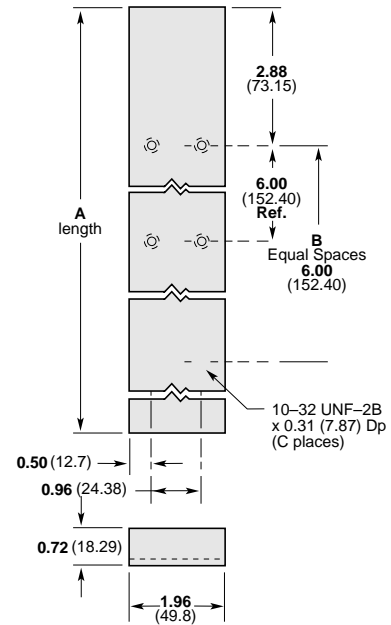
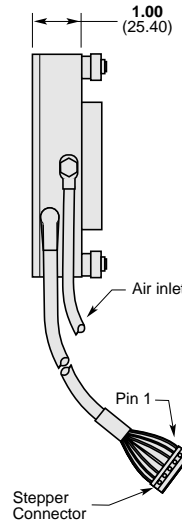

Platen

### Platen Dimensions

Model	A (mm) Length	B # Spaces	C # Holes
PO-L20-P18	17.75 (451)	2	6
PO-L20-P36	35.75 (908)	5	12
PO-L20-P54	53.75 (1,365)	8	18
PO-L20-P72	71.75 (1,822)	11	24
PO-L20-P96	95.75 (2,432)	15	32
PO-L20-P144	143.75 (3,651)	23	48



## Artisan Technology Group is your source for quality new and certified-used/pre-owned equipment

- FAST SHIPPING AND DELIVERY
- TENS OF THOUSANDS OF IN-STOCK ITEMS
- EQUIPMENT DEMOS
- HUNDREDS OF MANUFACTURERS SUPPORTED
- LEASING/MONTHLY RENTALS
- ITAR CERTIFIED SECURE ASSET SOLUTIONS

### SERVICE CENTER REPAIRS

Experienced engineers and technicians on staff at our full-service, in-house repair center

### *InstraView*<sup>SM</sup> REMOTE INSPECTION

Remotely inspect equipment before purchasing with our interactive website at [www.instraview.com](http://www.instraview.com) ↗

### WE BUY USED EQUIPMENT

Sell your excess, underutilized, and idle used equipment. We also offer credit for buy-backs and trade-ins. [www.artisanng.com/WeBuyEquipment](http://www.artisanng.com/WeBuyEquipment) ↗

### LOOKING FOR MORE INFORMATION?

Visit us on the web at [www.artisanng.com](http://www.artisanng.com) ↗ for more information on price quotations, drivers, technical specifications, manuals, and documentation

**Contact us:** (888) 88-SOURCE | [sales@artisanng.com](mailto:sales@artisanng.com) | [www.artisanng.com](http://www.artisanng.com)