



Artisan Technology Group is your source for quality new and certified-used/pre-owned equipment

- FAST SHIPPING AND DELIVERY
- TENS OF THOUSANDS OF IN-STOCK ITEMS
- EQUIPMENT DEMOS
- HUNDREDS OF MANUFACTURERS SUPPORTED
- LEASING/MONTHLY RENTALS
- ITAR CERTIFIED SECURE ASSET SOLUTIONS

SERVICE CENTER REPAIRS

Experienced engineers and technicians on staff at our full-service, in-house repair center

*InstraView*SM REMOTE INSPECTION

Remotely inspect equipment before purchasing with our interactive website at www.instraview.com ↗

WE BUY USED EQUIPMENT

Sell your excess, underutilized, and idle used equipment. We also offer credit for buy-backs and trade-ins. www.artisanng.com/WeBuyEquipment ↗

LOOKING FOR MORE INFORMATION?

Visit us on the web at www.artisanng.com ↗ for more information on price quotations, drivers, technical specifications, manuals, and documentation

Contact us: (888) 88-SOURCE | sales@artisanng.com | www.artisanng.com

Lamp Power Supply

OPERATION MANUAL

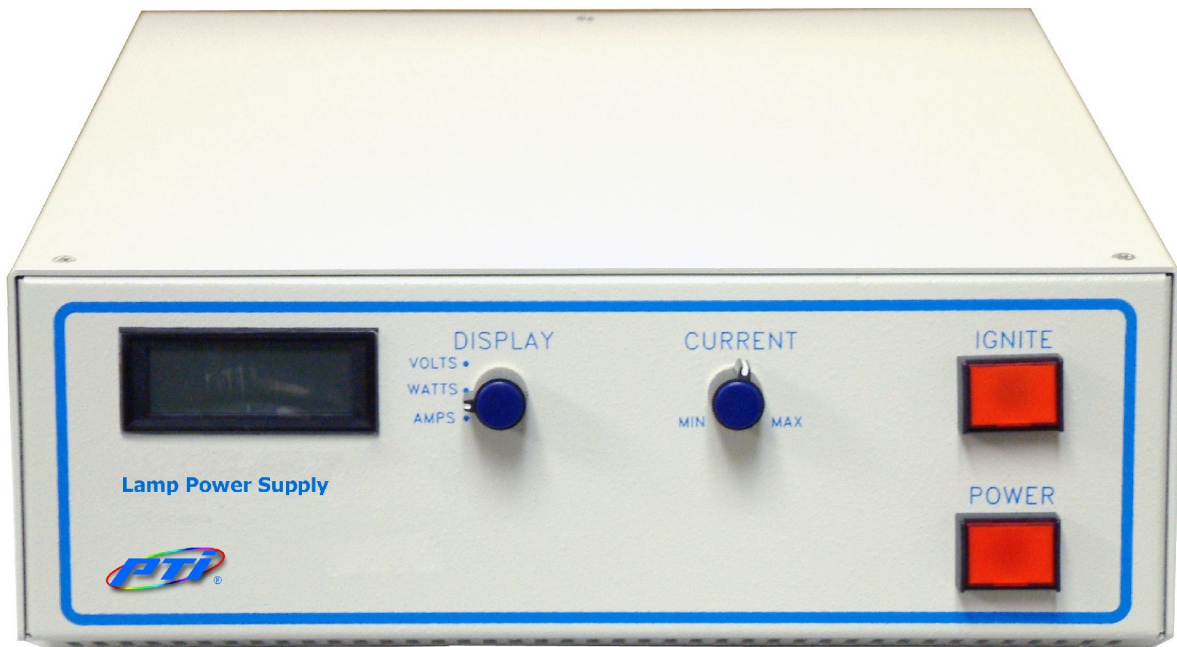

Photon Technology International

Trademark and Proprietary Information

All materials on this document, including but not limited to: text, images, and illustrations (collectively, the "Materials") are owned or controlled by PTI. Trademarks apply. The materials contained in this document are subject to change without notice. PTI makes no warranty of any kind with regard to this material and shall not be liable for errors contained herein or for incidental consequential damages in connection with the furnishings, performance, or use of this material.

You may not copy, reproduce, republish, upload, post, transmit or distribute the materials in any way whatsoever without prior written approval from authorized personnel of Photon Technology International.

PTI® and the PTI logo are registered trademarks of Photon Technology International, Inc. The following product names are all trademarks of PTI:

- DeltaScan™
- DeltaRAM™
- FeliX™
- ImageMaster™
- ImageMaster Pro™
- QuadraCentric™
- QuadraScopic™
- QuantaMaster™
- RatioMaster™
- TimeMaster™
- TimeMaster Pro™
- Oscar™
- Power Filter™
- Filter Scan™
- Felix32™
- Brytebox™

No trademark and no material from any PTI documentation may be used in any form without prior written permission from Photon Technology International, Inc. All other trademarks are the property of their owners.

Copyright © 2007 PTI. All Rights Reserved. PTI is a registered trademark of Photon Technology International, Inc., 300 Birmingham Road, P.O. Box 272, Birmingham, NJ 08011 Phone: (609) 894-4420 Fax: (609) 894-1579. Website: www.pti-nj.com Specifications and contents are subject to change without notice.

PTI Standard Instrument Warranty

Warranty Period and Extent

Photon Technology International (PTI) warrants that its instruments will be delivered in a functional state and free from defect, and will meet stated specifications for a period of one (1) year. The warranty period will start on the date of shipment by PTI. In case of systems that include installation by PTI, the warranty will start from the date of installation or thirty (30) days after the shipping date, whichever is earlier.

This warranty is in lieu of all other warranties, expressed or implied, including, without limitation, the implied warranties of merchantability and fitness for a particular purpose, nor will PTI provide training on its use free of charge. PTI shall not be responsible for any liability, loss or damages, caused or alleged to be caused, by the system, as a result of use or operation including, without limitation, consequential damages and loss of profit.

Specific Exclusions and Limitations

1. It is recognized that the performance of consumable items will diminish as a function of use, and that it may be necessary to replace such items to restore the stated specifications. Consumable items (arc lamps, filters, cuvettes, lenses, etc.) are not covered by the warranty.
2. The original manufacturer's warranty will be maintained for major system components not manufactured by PTI (e.g. computers, printers, microscopes, cameras and components thereof).
3. Fiber optic bundles are not covered by the warranty.
4. The use of arc lamps not supplied by PTI (or approved in writing by PTI) will void PTI's warranty on all illuminator subsystem components.
5. If there is any evidence of physical contact with coated optics (e.g. fingerprints), the warranty on that item will be voided.
6. If the optical components are realigned by the customer without specific permission from PTI, the warranty will be voided. Please note that the customer is responsible for changing lamps and aligning the lamp after installation. Aligning the lamp will not void the warranty unless other exclusions are applicable (nos. 4 and 5).
7. Instrument systems that are not authorized to be installed by anyone other than PTI service personnel will not be warranted.
8. In case of systems that include installation as part of the original purchase, unpacking the instrument by anyone other than PTI personnel will void the warranty.
9. Moving systems to another site within a facility or to another location, without specific permission from PTI, will void the warranty.
10. Damage or loss caused by shipping is not covered by the warranty.
11. Damage caused by improper operation of the instrument will void the warranty.
12. Damage caused by equipment not purchased from PTI that is attached to the instrument is not covered by the warranty.
13. Warranty is valid only in the state, province or country of the original purchase.
14. Warranty is valid only on systems having a computer supplied by PTI.
15. Software upgrades performed on the PTI computer workstation (e.g., adding word processors, image editors, etc.) not authorized by PTI will void the warranty.
16. Hardware upgrades performed on the PTI computer workstation (e.g., adding network boards, sound cards, etc.) not authorized by PTI will void the warranty.

Warranty Returns

A Return Material Authorization (RMA) Number must be obtained from the PTI Service Department before any items can be shipped to the factory. Returned goods will not be accepted without an RMA Number. Customer will bear all shipping charges for warranty repairs. All goods returned to the factory for warranty repair should be properly packed to avoid damage and clearly marked with the RMA Number.

Warranty Repairs

Warranty repairs will be done either at the customer's site or at the PTI plant, at our option. All service rendered by PTI will be performed in a professional manner by qualified personnel.

Software

PTI makes no warranties regarding either the satisfactory performance of the software or the fitness of the software for any specific purpose. PTI shall not be responsible for any liability, loss or damages caused or alleged to be caused by our software as a result of its use, including, without limitation, consequential damages and loss of profit, nor will PTI provide training on its use free of charge.

Safety Symbols Used In This Manual

(NOTE: Not all may be present in this manual)



(DANGER)

This symbol indicates the potential for serious bodily harm. Extreme care should be taken when performing the task and all warnings should be strictly adhered to. All possible steps should be taken to ensure safety.



(WARNING)

This symbol represents the potential for electrical shock and/or other bodily harm. Care should be taken when performing the task. There is also the potential for damage to equipment if warnings are not taken seriously.



(CAUTION)

This symbol represents the potential for equipment damage. The user is expected to use care when performing the task.



(RADIATION)

This symbol represents the risk of UV radiation. User must take all appropriate steps to protect eyes and exposed areas of the skin.

Main Safety Precautions

UV PRECAUTIONS

- Never look directly at an operating lamp; severe eye injury will result. Wear UV protective lenses, such as a welder's helmet, when working around operating lamps. Care should also be taken to ensure that exposed areas of the skin are protected.

HANDLING OF LAMPS

- Compact arc lamps contain a highly pressurized gas, and present an explosion hazard *even when cold*. Wear face protection, such as a welder's helmet, whenever handling lamps.
- Some lamps can only be mounted one way in the lamp housing since the anode (+) and cathode (-) have different diameters. However, some lamps have the same diameter anode and cathode that could lead to an orientation error. **OBSERVE POLARITY!**
- The anode adapter should not put any mechanical stress on the lamp. It may be necessary to bend the electrical wire connected to the adapter slightly in order to relieve any stress on the lamp.
- Never touch the quartz envelope with bare hands; such handling may lead to deterioration and premature failure of the arc lamp, and consequentially, a potential for the lamp to explode. Soft cotton gloves should be worn when removing and installing lamps.
- For 150 watt lamps, failure to check for leaks could result in flooding of the lamp housing, and presents explosion and electrocution hazards.
- Failure to maintain proper cooling may result in lamp damage and possibly lamp explosion.
- Pressurized lamps operate at **VERY HIGH TEMPERATURES** and therefore care must be taken when handling the lamps.

IGNITER PRECAUTIONS

- The igniter produces very high voltage levels that can be fatal. **EXTREME CARE** should be taken when operating the igniter.
- Never operate an igniter without a lamp attached. Otherwise the voltage rises to a lethal level, and may cause damage to the igniter and power supply.
- Do not open the power supply or igniter cases. High voltage is present, and there are no user-serviceable parts inside.
- It is strongly recommended that the lamp power supply be connected to an isolated line supply to minimize electrical interference with other devices such as computers, photomultiplier detectors, etc. Also, physically position the power supply and igniter as far away as possible from computers, signal cables and other electrically sensitive items.

Contents

Trademark and Proprietary Information	1
PTI Standard Instrument Warranty	2
Safety Symbols Used In This Manual	3
Main Safety Precautions.....	4
Contents	5
List of Figures.....	5
1 Description.....	6
1.1 Introduction	6
1.2 Specifications	7
2 Installation	8
2.1 Arc Lamps	8
2.2 Tungsten-Halogen Lamps	9
3 Operation	11
3.1 Arc Lamps:	11
3.2 Tungsten-Halogen Lamps	12
4 Service	13
4.1 Troubleshooting	13
4.1.1 If the lamp fails to ignite:.....	13
4.1.2 If the front panel LCD display is blank while power is on:.....	13
4.2 Replacing the fuses.....	14
4.2.1 Line (Mains) Fuse:.....	14
4.2.2 Overload Protection Fuse:.....	14
4.3 Interfacing an Optical Feedback System	16
5 Service Calls to PTI.....	18

List of Figures

Figure 1 - Connections for Arc Lamps	<u>89</u>
Figure 2 - Connections for Tungsten Lamps	<u>104</u>
Figure 3 - Front Panel Settings	<u>114</u>
Figure 4 - Fuse Replacement	<u>154</u>
Figure 5 - Accessory Connector	<u>164</u>
Figure 6 - Optical Feedback System Layout.....	<u>174</u>

1 Description

1.1 Introduction



When operating an arc lamp, this Lamp Power Supply may only be used in conjunction with an Igniter that mounts on top of the Arc Lamp Housing.

Do NOT use this this Lamp Power Supply with a PTI model LPS-221 Igniter (connected to the Arc Lamp Housing by two cables). Attempting to interchange components of different versions (unless specified by qualified PTI personnel) WILL result in permanent damage to the equipment and WILL void the warranty.

The Lamp Power Supply is a highly regulated DC power supply that provides very stable power for Xenon, Mercury, and Mercury/ Xenon compact arc lamps as well as Tungsten-Halogen lamps from 75 to 150 watts. An external lamp igniter is provided for arc lamps.

When the power supply is initially turned on and before the lamp is ignited, approximately +100 V appears across the output terminals. Pressing the IGNITE button applies +100 V to the igniter, which triggers the igniter to send a 30 kV pulse to the lamp, thereby creating an arc between the lamp's electrodes.

The output current is set using the CURRENT control. The output voltage is automatically adjusted to maintain the desired current. Since the current is very accurately regulated, the resulting lamp power is highly stable for Xenon lamps, following a five-minute warm-up period. A digital meter displays lamp volts, watts or amps according to the setting of the DISPLAY selector.

The unit is air cooled with an internal fan that vents through the heat sink on the rear panel. Proper ventilation is required for reliable operation; the unit should not be placed directly against a wall or another device.

1.2 Specifications

Electrical:

Input (user selectable):	105-132 V/60 Hz or 210-264 V/50 Hz
Fuses	
Line (Mains) Fuse (105-132 V):	4 Amp, 250 V slow blow
Line (Mains) Fuse (210-264 V):	2 Amp, 250 V slow blow
Overload protection fuse:	10 Amp, 250 V fast blow
Power Rating:	0 to 150 W
Operating Voltage:	12 to 24 V
Operating Current:	0 to 8 A
Pre-Ignition Voltage:	> 85 V
Ripple at Maximum Current:	< 10 mV
Stability After Warm-up:	0.2 %
Line Voltage Regulation:	0.1 % Current Variation for 5 volts Line Change
Load Regulation:	0.1 % Current Variation for 50 % Change in Load Impedance

Physical:

Dimensions:	4.5 H x 10.75 W x 12.5 D inches 115 H x 273 W x 318 D mm
-------------	---

Add a minimum of 2 inches (50 mm) at the back when attaching the igniter cable and power (mains) cord.

Weight:	12 pounds 5.4 kg
---------	---------------------

2 Installation

2.1 Arc Lamps

1. Connect the lamp power supply to the igniter using the gray igniter cable supplied. Verify the proper polarity of the connector by looking at the connectors at each end of the cable and the mating connectors on the components. The male end of the cable must plug into the female connector on the lamp power supply (see **Figure 1**). The female end of the cable must plug into the male connector on the igniter.
2. Verify the proper fuse selection for the lamp power supply. The fuse selection is determined by the small circuit card located in the Line (Mains) Module on the rear of the lamp power supply. (see [Replacing The Fuses](#)).
3. With the proper fuse and circuit card selection in place, plug the Line (Mains) cord supplied from the lamp power supply into the appropriate Line (Mains) outlet.
4. Verify the appropriate selection of the Auto/Manual Ignite switch located on the rear of the lamp power supply. If MANUAL is selected, the IGNITE button on the front of the lamp power supply will be used to ignite the lamp. It will take approximately 15 seconds to ignite the lamp. If AUTO is selected, the lamp power supply will automatically ignite the lamp approximately 15 seconds after the power is switched on. In the event of a power out condition (if AUTO is selected), the lamp power supply will automatically re-ignite the lamp.



Automatic re-ignition after a power failure and return of power may cause damage to other electrical equipment if they turn on before the lamp has re-ignited.

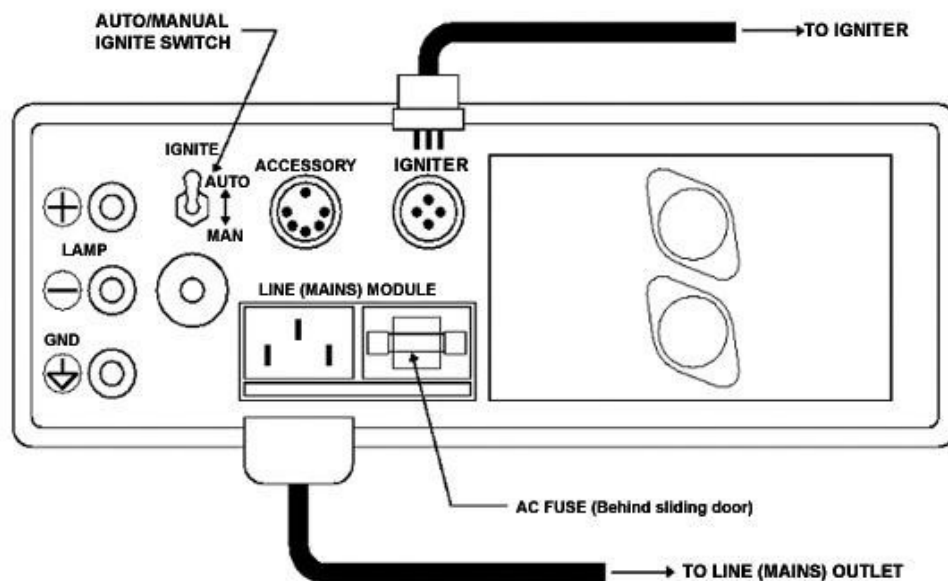

Figure 1 - Connections for Arc Lamps

2.2 Tungsten-Halogen Lamps

1. The lamp power supply connects directly to the lamp housing using the separate red and black cables supplied (see **Figure 2**). I.e., the igniter and igniter cable are not used.
 - a. Connect the red wire from the red (+) connector on the lamp power supply to the red (+) connector on the lamp housing.
 - b. Connect the black wire from the black (-) connector on the lamp power supply to the black (-) connector on the lamp housing.
 - c. The green (GND) connector on the lamp power supply is not used.



Improper connection can result in damage to the lamp and the power supply.



Never use the igniter when powering a Tungsten- Halogen lamp. If the system has been previously connected for arc lamp use, disconnect the igniter and igniter cable from the lamp power supply and the lamp Housing.

2. Verify the proper fuse selection for the lamp power supply. The fuse selection is determined by the small circuit card located in the Line (Mains) Module on the rear of the lamp power supply (see [Replacing the Fuses](#)).
3. With the proper fuse and circuit card selection in place, plug the Line (Mains) cord supplied from the lamp power supply into the appropriate Line (Mains) outlet.
4. The Auto/Manual Ignite switch is not used for Tungsten-Halogen lamps, and may be set in either position.

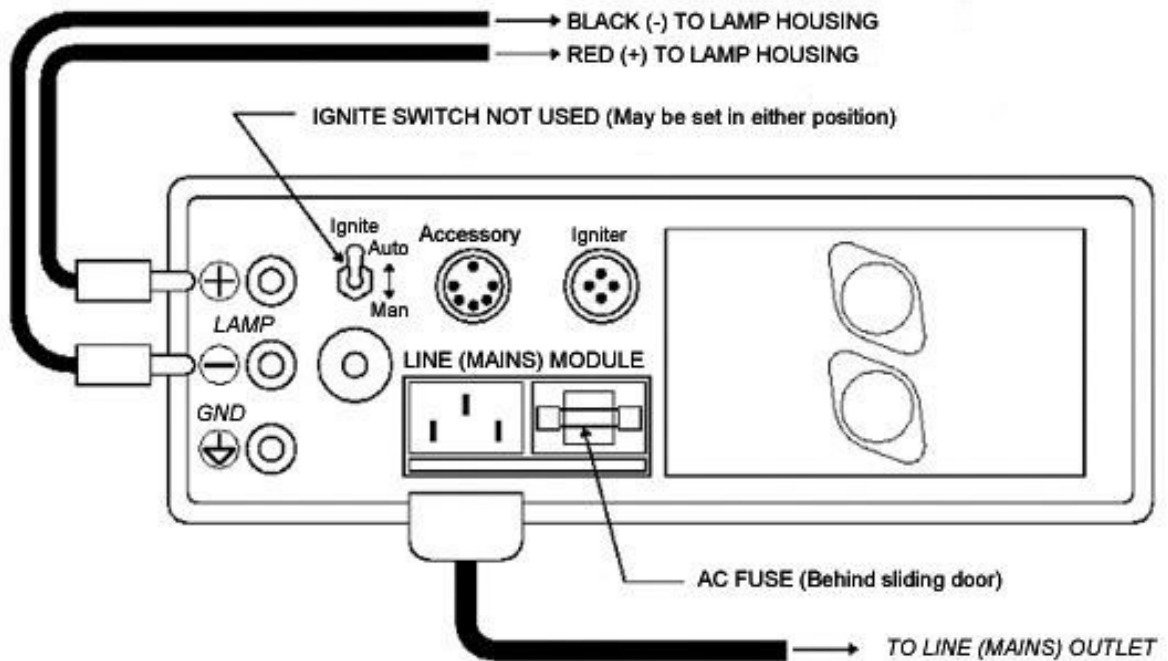

Figure 2 - Connections for Tungsten Lamps

3 Operation

3.1 Arc Lamps:



Never operate the lamp power supply without a lamp attached, otherwise the voltage will rise to a lethal level, and may cause damage to the components.



It is strongly recommended that the Auto/Manual Ignite switch on the rear panel be set in the “manual” position when first igniting a new lamp. This way, the user can determine that the current is set properly without the lamp power supply automatically igniting the lamp. After the user has determined that the current has been set properly for the new lamp (see [Table 1](#)), and after the lamp has been ignited successfully at least once, the Auto/Manual Ignite switch may then be changed to “AUTO” for normal operation. **NOTE:** In the event of a power out condition (if AUTO is selected), the lamp power supply will automatically re-ignite the lamp. This may cause damage to other electrical equipment if they turn on before the lamp has re-ignited.

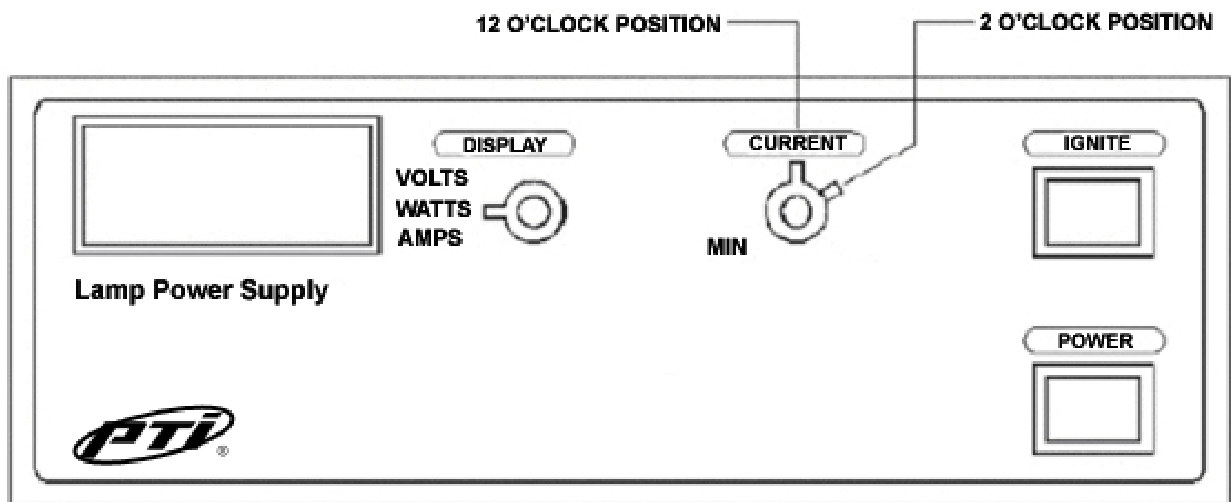

Figure 3 - Front Panel Settings

1. Set the DISPLAY selector to WATTS.
2. Pre-set the Current Control Switch to approximately:
 - 12 o'clock position** for 75 or 100 watt lamps
 - 2 o'clock position** for 150 watt lamps

3. Turn on the lamp power supply by pressing the button labeled POWER.
4. If the Auto/Manual Ignite Switch is set to the “AUTO” position, skip to step 6.
5. Press and hold the IGNITE button until the lamp ignites, then release button.
6. After the lamp is ignited, wait approximately 5 minutes for warm-up, then adjust the CURRENT control as necessary to provide the lamp with its rated wattage (see **Table 1. Lamp Specifications**).
7. The lamp is extinguished by turning the power supply off.

NOTE:

*As the lamp becomes less efficient due to age and wear, the current setting must be periodically increased to compensate and maintain the desired power level(wattage). Xenon lamps with greater than 600 hours usage, or Mercury lamps with greater than 200 hours usage, or any lamp which requires a voltage setting higher than the maximum specified in the following table (**Table 1. Lamp Specifications**) should be replaced. The voltage setting can be checked by switching the Display Selector to VOLTS while the lamp is ignited.*

Lamp Type and Rated Wattage	Nominal Operating Voltage	Maximum Operating Voltage
75 W Xenon	12 – 14 volts	15 volts
100 W Mercury	12 – 14 volts	15 volts
150 W Xenon	17.5 – 20 volts	20.5 volts

Table 1 - Lamp Specifications

3.2 Tungsten-Halogen Lamps



Never operate the lamp power supply without a lamp attached, otherwise the voltage will rise to a lethal level, and may cause damage to the components.

1. Set the DISPLAY selector to WATTS.
2. Set the CURRENT to 0 (MIN).
3. Turn on the lamp power supply by pressing the button labeled POWER.
4. Slowly turn the current up, making sure not to exceed the rated wattage of the lamp (see **Table 1. Lamp Specifications**).
5. The lamp is extinguished by turning the power supply off.

4 Service

4.1 Troubleshooting

4.1.1 If the lamp fails to ignite:

1. **Turn off the power** switch on front panel.
2. Remove the lamp power supply AC cord from both the wall plug and the rear panel.
3. Check all electrical connections as specified in the *Installation* section.
4. Check the Line (Mains) Fuse for visual defects and/or test with an ohm meter. Replace as necessary (see [Replacing The Fuses](#))
5. Check the condition of the lamp and replace as necessary.
6. Reconnect the lamp power supply AC cord to both the wall plug and the rear panel.
7. Turn on power switch on front panel.
8. Check the volts/watts/amps settings as specified in the *Operation* section.
9. If the lamp still fails to ignite, call PTI for assistance.

4.1.2 If the front panel LCD display is blank while power is on:

1. **Turn off the power** switch on front panel.
2. Remove the lamp power supply AC cord from both the wall plug and the rear panel.
3. Check the Overload Protection Fuse for visual defects and/or test with an ohm meter. Replace as necessary (see [Replacing The Fuses](#)).
4. Reconnect the lamp power supply AC cord to both the wall plug and the rear panel.
5. Turn on power switch on front panel.
6. If the LCD display remains blank, call PTI for assistance.



Do not open the power supply or igniter cases. High voltage is present, and there are no user-serviceable parts inside.

4.2 Replacing the fuses

4.2.1 Line (Mains) Fuse:



Any fuse that fails repeatedly is potentially indicating a problem of a serious nature. In the event that a fuse fails shortly after, or upon replacement, contact PTI for assistance.

1. **Turn off the power** switch on front panel.
Remove the lamp power supply AC cord from both the wall plug and the rear panel.
2. Slide the plastic fuse cover to the left to expose the fuse and its removal lever.
3. Pull the lever labeled “FUSE PULL” outward and to the left and remove the fuse.
4. The fuse selection is determined by the small circuit card located under the fuse in the Line (Mains) Module on the rear of the lamp power supply. The current AC Voltage selection can be read on the top of the card while it is in place. If it is incorrect, use a pair of needle nose pliers to pull the card straight out and orient it so either 120 or 240 can be read when the card is in place (120 is for the range 105 – 132 VAC and 240 is for the range 210 – 264 VAC. The 110 or 220 V selections are not needed and are not wired).
5. Move the fuse lever back into place before replacing the fuse.
6. Replace with the appropriate fuse from the following table:

AC Voltage	Fuse Specification
105 - 132 VAC	3AB, 4 Amp, 250 V slow blow
210 - 264 VAC	3AB, 2 Amp, 250 V slow blow

Table 2 - Lamp Power Supply Replacing Mains Fuse

7. Slide the plastic fuse cover to the right and reconnect the AC cord.

4.2.2 Overload Protection Fuse:

1. **Turn off the power** switch on front panel.
Remove the lamp power supply AC cord from both the wall plug and the rear panel.
2. Gently push the black fuse holder in, while turning it counter-clockwise.
3. Remove the fuse.
4. Replace with a 10 A, fast blow, 250 V fuse.
5. Push the fuse holder in and rotate it clockwise until seated.

6. Reconnect the AC cord.

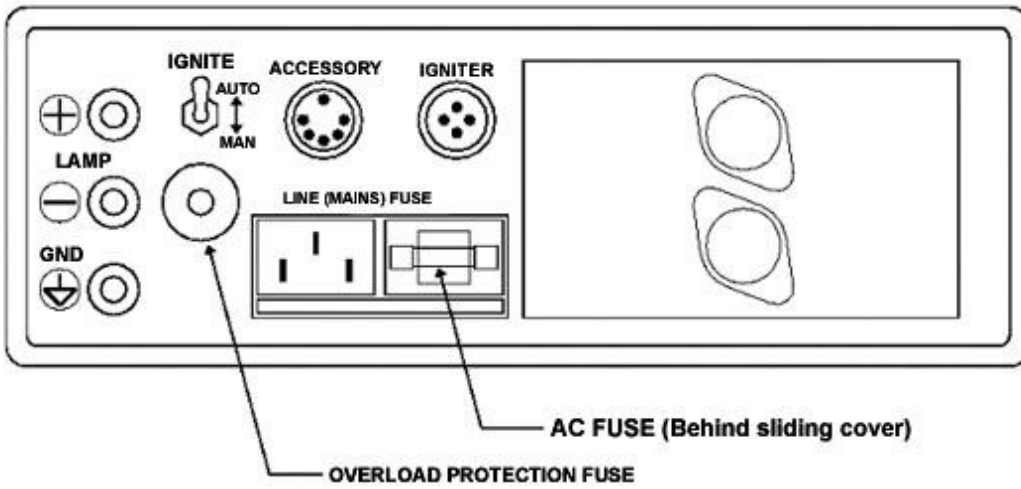

Figure 4 - Fuse Replacement

4.3 Interfacing an Optical Feedback System

The lamp power supply can accommodate various optical feedback systems if appropriate measures are taken concerning signal level and polarity. Although the lamp power supply has a current stability specification of better than 0.1 %, this stability may not necessarily translate into optical stability of the same magnitude. Due to inherent instabilities and fluctuations, and depending on the manufacturer and type of lamp, the actual optical output can vary as much as 2 % to 3 % over a period of a few hours.

Provision has been made in the lamp power supply for external feedback control, which may be used to implement an optical feedback system. The accessory connector on the rear panel of the power supply (see **Figure 5**) provides the feedback control input, as well as +15 and -15 volts DC, which may be used for powering external devices. The feedback connection accepts a positive DC signal in the range of 0 to +5 volts, with the current supplied to the lamp being proportional to the signal voltage. This connection is DC coupled, and in conjunction with the front panel control, provides complete control of the lamp current supply.

- 0** Ground
- 1** -15 VDC
- 2** Ground
- 3** Feedback Input (0-5 VDC)
- 4** N.C.
- 5** +15 VDC

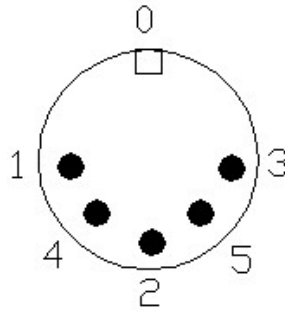

Figure 5 - Accessory Connector

In a normal optical feedback control system, the detector and amplifier are used in a negative feedback control loop such that any change in the optical input is compensated for by a change in the lamp current. If, for example, the optical output decreases for any reason, the detector/amplifier signal would increase, and the lamp power supply would increase the lamp current to compensate.

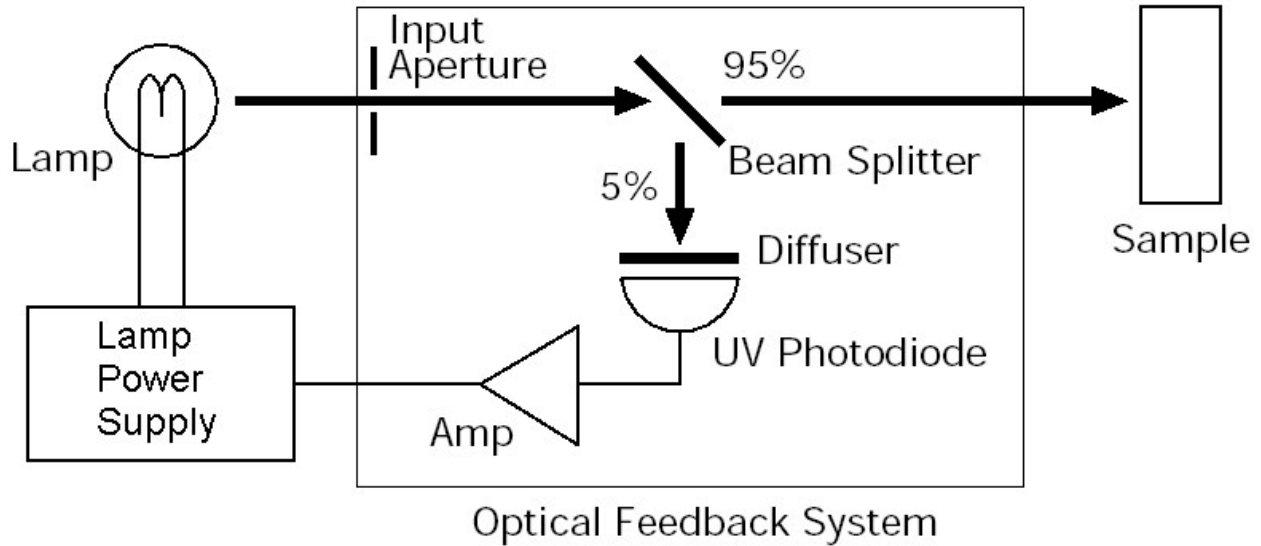

Figure 6 - Optical Feedback System Layout

Referring to figure 6, notice that a portion of the optical beam to be controlled is sampled with the use of an input aperture and a beam splitter. The beam sample is reflected by the beam splitter onto an optical diffuser. Located behind the diffuser is a stable UV photodiode that is coupled to a variable gain amplifier. The amplifier output must be inverted in order to provide negative feedback, so that an increase of detected optical output will result in a lower DC signal to the power supply.

The amplifier should have an adjustable offset control such that the DC output can be shifted into the range of 0 to +5 volts. It should also have adjustable upper and lower limit controls so that the lamp current cannot be varied by more than 20 % around the normal lamp current. This is necessary in order to prevent accidental lamp destruction due to unusual optical conditions, such as during adjustment and testing.

The amplifier should be a very stable device with a variable DC offset. It may be AC coupled, in which case only the variations in intensity above a certain frequency (the low frequency cutoff point) will be compensated for. This arrangement is easier to implement and less prone to trouble during adjustment and alignment. If very stable performance down to DC is required, the amplifier must, of course, be DC coupled, and great care must be taken during initial alignment and testing.

5 Service Calls to PTI

Before calling for service, please review the [Troubleshooting](#) section. To aid our Service Department in discussing your questions, as well as to aid in the timely solution of any problems, please assemble as much as possible of the following information before calling PTI:

- Your system serial number, or as many other component serial numbers as possible
- Your instrument type and hardware configuration (and software version, if applicable)
- The date on which your instrument was installed
- As much detail as possible on the particular chain of events or circumstances that led to the problem. This information should include the complete instrument status and data gathering protocol.

Contact PTI Service at
Toll Free: 877-784-4349 US/Canada
Phone: 609 894-4420 Ext 115
Fax: 609 894-1579
Email: service@pti-nj.com

VISIT OUR WEBSITE AT
www.pti-nj.com



Artisan Technology Group is your source for quality new and certified-used/pre-owned equipment

- FAST SHIPPING AND DELIVERY
- TENS OF THOUSANDS OF IN-STOCK ITEMS
- EQUIPMENT DEMOS
- HUNDREDS OF MANUFACTURERS SUPPORTED
- LEASING/MONTHLY RENTALS
- ITAR CERTIFIED SECURE ASSET SOLUTIONS

SERVICE CENTER REPAIRS

Experienced engineers and technicians on staff at our full-service, in-house repair center

*InstraView*SM REMOTE INSPECTION

Remotely inspect equipment before purchasing with our interactive website at www.instraview.com ↗

WE BUY USED EQUIPMENT

Sell your excess, underutilized, and idle used equipment. We also offer credit for buy-backs and trade-ins. www.artisanng.com/WeBuyEquipment ↗

LOOKING FOR MORE INFORMATION?

Visit us on the web at www.artisanng.com ↗ for more information on price quotations, drivers, technical specifications, manuals, and documentation

Contact us: (888) 88-SOURCE | sales@artisanng.com | www.artisanng.com