



## Artisan Technology Group is your source for quality new and certified-used/pre-owned equipment

- FAST SHIPPING AND DELIVERY
- TENS OF THOUSANDS OF IN-STOCK ITEMS
- EQUIPMENT DEMOS
- HUNDREDS OF MANUFACTURERS SUPPORTED
- LEASING/MONTHLY RENTALS
- ITAR CERTIFIED SECURE ASSET SOLUTIONS

### SERVICE CENTER REPAIRS

Experienced engineers and technicians on staff at our full-service, in-house repair center

### *InstraView*<sup>SM</sup> REMOTE INSPECTION

Remotely inspect equipment before purchasing with our interactive website at [www.instraview.com](http://www.instraview.com) ↗

### WE BUY USED EQUIPMENT

Sell your excess, underutilized, and idle used equipment. We also offer credit for buy-backs and trade-ins. [www.artisanng.com/WeBuyEquipment](http://www.artisanng.com/WeBuyEquipment) ↗

### LOOKING FOR MORE INFORMATION?

Visit us on the web at [www.artisanng.com](http://www.artisanng.com) ↗ for more information on price quotations, drivers, technical specifications, manuals, and documentation

**Contact us:** (888) 88-SOURCE | [sales@artisanng.com](mailto:sales@artisanng.com) | [www.artisanng.com](http://www.artisanng.com)



---

Instruction Manual J-3631-1

---

**4 Channel**  
**Analog Output Module**  
M/N 57C410

The information in this user's manual is subject to change without notice.

**WARNING**  
THIS UNIT AND ITS ASSOCIATED EQUIPMENT MUST BE INSTALLED, ADJUSTED AND MAINTAINED BY QUALIFIED PERSONNEL WHO ARE FAMILIAR WITH THE CONSTRUCTION AND OPERATION OF ALL EQUIPMENT IN THE SYSTEM AND THE POTENTIAL HAZARDS INVOLVED. FAILURE TO OBSERVE THESE PRECAUTIONS COULD RESULT IN BODILY INJURY.

**WARNING**  
INSERTING OR REMOVING THIS MODULE OR ITS CONNECTING CABLES MAY RESULT IN UNEXPECTED MACHINE MOTION. POWER TO THE MACHINE SHOULD BE TURNED OFF BEFORE INSERTING OR REMOVING THE MODULE OR ITS CONNECTING CABLES. FAILURE TO OBSERVE THESE PRECAUTIONS COULD RESULT IN BODILY INJURY.

**CAUTION**  
THIS MODULE CONTAINS STATIC-SENSITIVE COMPONENTS. CARELESS HANDLING CAN CAUSE SEVERE DAMAGE.  
DO NOT TOUCH THE CONNECTORS ON THE BACK OF THE MODULE. WHEN NOT IN USE, THE MODULE SHOULD BE STORED IN AN ANTI-STATIC BAG. THE PLASTIC COVER SHOULD NOT BE REMOVED. FAILURE TO OBSERVE THIS PRECAUTION COULD RESULT IN DAMAGE TO OR DESTRUCTION OF THE MATERIAL.

Reliance® is a registered trademark of Reliance Electric Company or its subsidiaries.

# Table of Contents

1.0	Introduction .....	1-1
2.0	Mechanical/Electrical Description .....	2-1
	2.1 Mechanical Description .....	2-1
	2.2 Electrical Description .....	2-1
3.0	Installation .....	3-1
	3.1 Wiring .....	3-1
	3.2 Initial Installation .....	3-1
	3.3 Module Replacement .....	3-4
4.0	Programming .....	4-1
	4.1 Register Organization .....	4-1
	4.2 Configuration .....	4-1
	4.3 Reading And Writing Data In Application Tasks .....	4-2
	4.3.1 BASIC Task Example .....	4-2
	4.3.2 Control Block Task Example .....	4-2
	4.4 Restrictions .....	4-2
	4.4.1 Data Limitations .....	4-2
5.0	Diagnostics And Troubleshooting .....	5-1
	5.1 Incorrect Data .....	5-1
	5.2 Bus Error .....	5-3

# Appendices

- Appendix A Technical Specifications ..... A-1
- Appendix B Module Block Diagram ..... B-1
- Appendix C Field Connections ..... C-1
- Appendix D Related Components ..... D-1
- Appendix E Defining Variables in the Configuration Task ..... E-1

## List of Figures

Figure 2.1 - Typical Output Circuit .....	2-2
Figure 2.2 - Module Faceplate .....	2-3
Figure 3.1 - Typical Field Connections for Voltage Output .....	3-2
Figure 3.2 - Typical Field Connections for 4-20 ma Current Output .....	3-2
Figure 3.3 - Rack Slot Numbers .....	3-3
Figure 4.1 - Organization of Register Bits .....	4-1



# 1.0 INTRODUCTION

The products described in this instruction manual are manufactured or distributed by Reliance Electric Company or its subsidiaries. This 4 Channel Analog Output Module contains four 12-bit D/A converter channels. Each channel can provide  $\pm 5$  volts,  $\pm 8$  volts,  $\pm 10$  volts, or a 4-20 ma current output. Output signals have 2500 volt isolation to logic common. Each channel has its own independent isolated common. The voltage outputs are current limited to protect the device in the event of a short circuit. Typically, this module is used to output voltage or current signals to devices such as drive and process controllers.

This manual describes the functions and specifications of the module. It also includes a detailed overview of installation and servicing procedures, as well as examples of programming methods. Related publications that may be of interest:

- J-2611 DCS 5000 PRODUCT SUMMARY
- J-3675 DCS 5000 ENHANCED BASIC LANGUAGE INSTRUCTION MANUAL
- J-3600 DCS 5000 CONTROL BLOCK LANGUAGE INSTRUCTION MANUAL
- J-3602 DCS 5000 LADDER LOGIC LANGUAGE INSTRUCTION MANUAL
- J-3629 DCS 5000 REMOTE I/O INSTRUCTION MANUAL
- J-3630 Resource AutoMax PROGRAMMING EXECUTIVE INSTRUCTION MANUAL VERSION 1.0
- J-3635 DCS 5000 PROCESSOR MODULE INSTRUCTION MANUAL
- J-3649 AutoMax CONFIGURATION TASK MANUAL
- J-3650 AutoMax PROCESSOR MODULE INSTRUCTION MANUAL
- J-3675 AutoMax ENHANCED BASIC LANGUAGE INSTRUCTION MANUAL
- J-3676 AutoMax CONTROL BLOCK LANGUAGE INSTRUCTION MANUAL
- J-3677 AutoMax LADDER LOGIC LANGUAGE INSTRUCTION MANUAL
- J-3684 Resource AutoMax PROGRAMMING EXECUTIVE INSTRUCTION MANUAL VERSION 2.0
- J-3750 Resource AutoMax PROGRAMMING EXECUTIVE INSTRUCTION MANUAL VERSION 3.0
- IEEE 518 GUIDE FOR THE INSTALLATION OF ELECTRICAL EQUIPMENT TO MINIMIZE ELECTRICAL NOISE INPUTS TO CONTROLLERS FROM EXTERNAL SOURCES





# 2.0 MECHANICAL/ELECTRICAL DESCRIPTION

The following is a description of the faceplate LEDs, field termination connectors, and electrical characteristics of the field connections.

## 2.1 Mechanical Description

The output module is a printed circuit board assembly that plugs into the backplane of the DCS 5000/AutoMax rack. It consists of a printed circuit board, a faceplate, and a protective enclosure. The faceplate contains tabs at the top and bottom to simplify removing the module from the rack. Module dimensions are listed in Appendix A.

The faceplate of the module contains a female connector socket and 4 LED indicators that show the status of the on-board isolated power supplies. Output signals leave the module via a multi-conductor cable (M/N 57C374; see Appendix D). One end of this cable attaches to the faceplate connector, while the other end of the cable has stake-on connectors that attach to a terminal strip for easy field wiring. The faceplate connector socket and cable plug are keyed to prevent the cable from being plugged into the wrong module. On the back of the module are two edge connectors that attach to the system backplane.

## 2.2

### Electrical Description

The output module contains 4 D/A converters that provide 12-bit resolution for  $\pm 5$  volts,  $\pm 8$  volts, and  $\pm 10$  volts, and 1-bit resolution for 4-20 ma current outputs. Each D/A converter has its own isolated common. Output signals have 2500 volt isolation to logic common. Refer to the block diagram in Appendix B. Each output circuit consists of three operational amplifiers. The first amplifier provides the voltage output. Jumpers are provided on the terminal strip to select an output range of 5, 8, or 10 volts. Current limiting is provided to protect the device against short circuits. A capacitor in the feedback path of this amplifier serves as a first order low pass output filter where the break frequency is approximately 100 Hz. The other two amplifiers are used to generate the 4-20 ma current output. A circuit diagram is shown in figure 2.1.

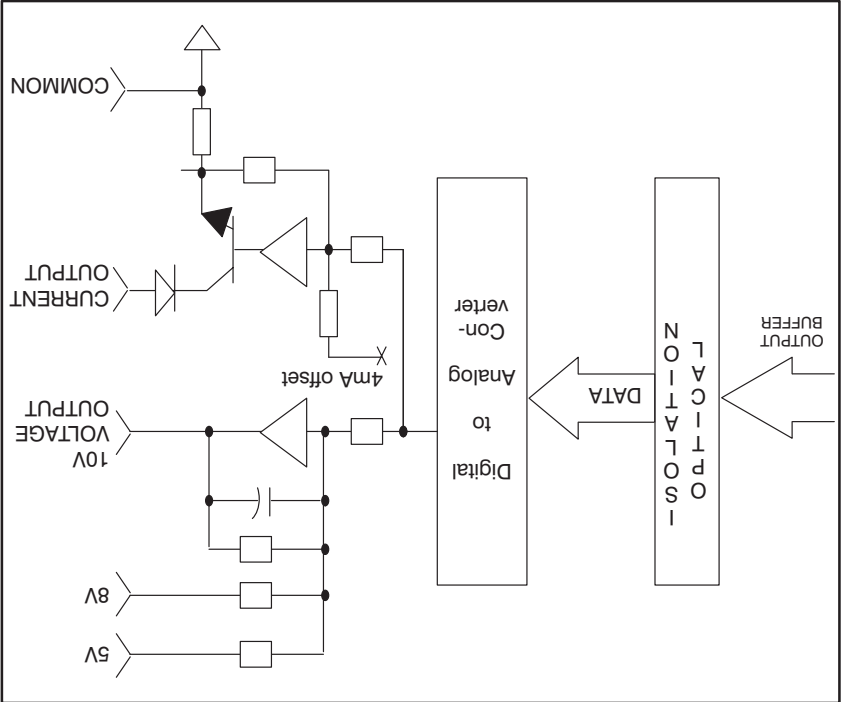
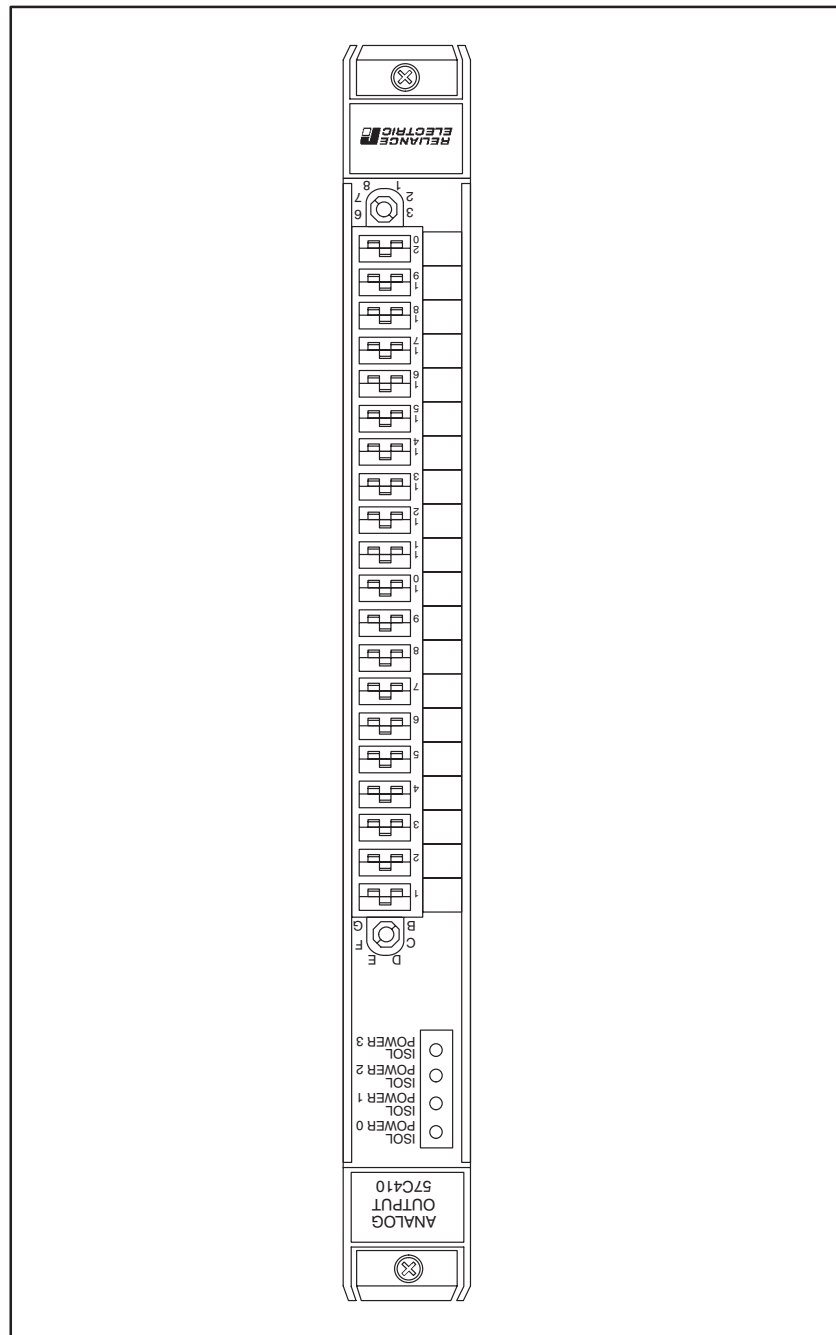

Figure 2.1 - Typical Output Circuit

There are 4 LED indicators on the faceplate of the module. The LEDs are arranged in the same order as the output terminals on the faceplate. They are numbered sequentially from zero through three, corresponding to the D/A converter channels. The LED indicators display the status of the four isolated power supplies on the module. A lit LED indicates that the power supply for that channel is operational. See figure 2.2.

Figure 2.2 - Module Faceplate





## 3.0 INSTALLATION

This section describes how to install and remove the module and its cable assembly.

### 3.1 Wiring

The installation of wiring should conform to all applicable codes. To reduce the possibility of electrical noise interfering with the proper operation of the control system, exercise care when installing the wiring from the system to the external devices. For detailed recommendations refer to IEEE 518.

### 3.2

#### Initial Installation

Use the following procedure to install the module:

Step 1. Turn off power to the system. All power to the rack as well as all power to the wiring leading to the module should be off.

Step 2. Mount the terminal strip (M/N 57C374) on a panel. The terminal strip should be mounted to permit easy access to the screw terminals. Make certain that the terminal strip is close enough to the rack so that the cable will reach between the terminal strip and the module.

Step 3. Fasten field wires to the terminal strip. Typical field connections for voltage output and for 4-20 ma current output are shown in figures 3.1 and 3.2, respectively. Refer to Appendix C for the arrangement of terminal strip connections. Note that for each channel there is only one common, regardless of whether voltage or current output is desired. If you require either 5 volt or 8 volt outputs, you must connect a jumper between the desired voltage and the voltage output on the terminal strip. Make certain that all field wires are securely fastened.

- Step 4. Take the module out of its shipping container. Take it out of the anti-static bag, being careful not to touch the connectors on the back of the module.
- Step 5. Insert the module into the desired slot in the rack. Refer to figure 3.3. Use a screwdriver to secure the module into the slot.

Figure 3.2 - Typical Field Connections for 4-20 ma Current Output

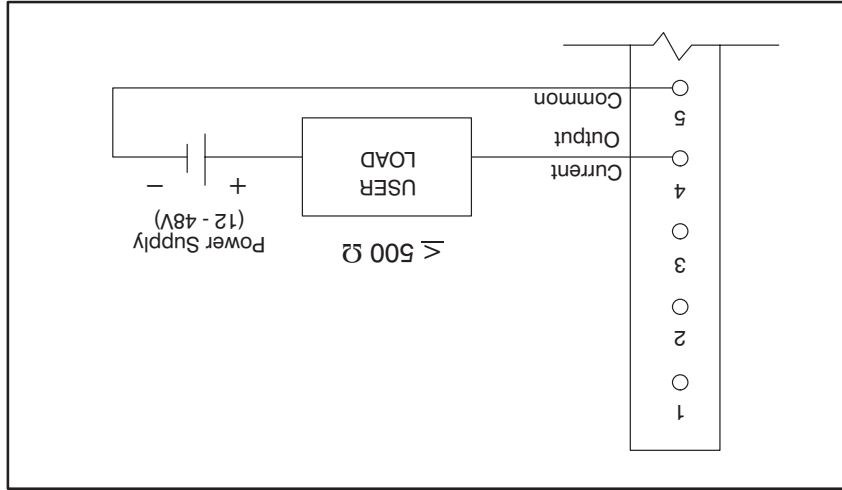
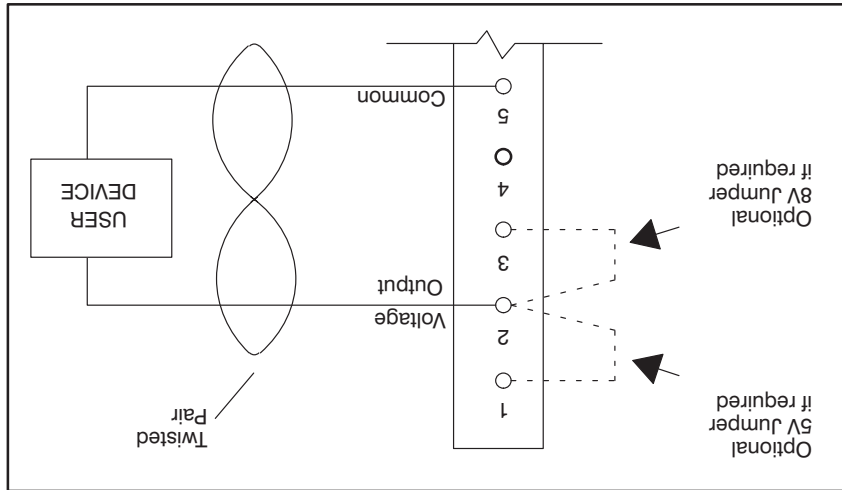

Figure 3.1 - Typical Field Connections for Voltage Output



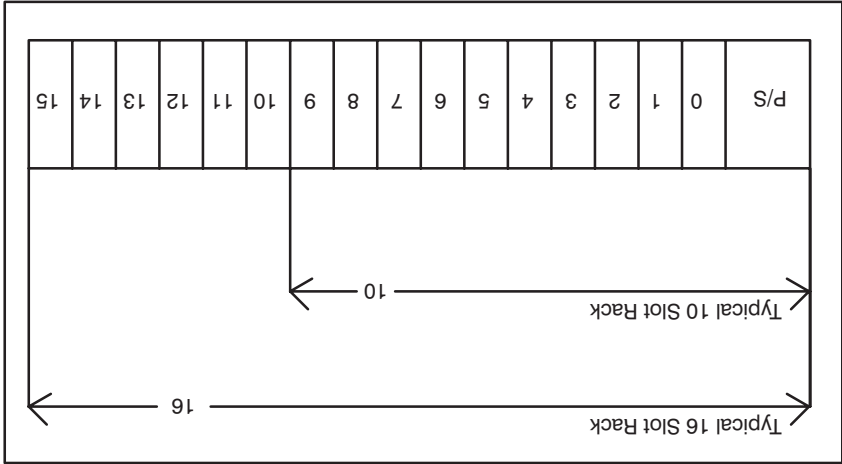

Figure 3.3 - Rack Slot Numbers

- Step 6. Attach the terminal strip connector (M/N 57C374) to the connector is the proper one for this module. Use a screwdriver to secure the connector to the module.
- Note that both the module and the terminal strip connector have "keys" that should be used to prevent the wrong cable from being connected to the module.
- Rotate the keys on the module and the connector so that they can be connected together securely. It is recommended that, for modules so equipped, the keys on each successive module in the rack be rotated one position to the right of the keys on the preceding module. Since the keys on the connectors must match their particular modules for the connector to fit, this method will eliminate the possibility of the wrong connector being plugged into a module.
- Step 7. Turn on power to the system. Verify that the four LEDs indicating each isolated power status are lit.
- Step 8. Verify the installation by connecting the programming terminal to the system and running the Resource Software.
- Stop all programs that may be running.
- Use the I/O MONITOR function. If the module is in the local rack, enter the module slot number and register (0-3, corresponding to the four D/A converter channels).
- If the module is in a remote rack, enter the module slot number of the master remote I/O module, remote I/O drop number (also called the remote rack number), output module slot number, and register (0-3).
- Write a series of values to each of the channels and verify the analog voltage with a voltmeter. Refer to table 1 for the approximate voltages or currents that should be read.



### 3.3 Module Replacement

Use the following procedure to replace a module:

- Step 1. Turn off power to the rack and all connections.
- Step 2. Use a screwdriver to loosen the screws holding the connector to the module. Remove the connector.
- Step 3. Loosen the screws that hold the module to the rack. Remove the module from the slot in the rack.
- Step 4. Place the module in the anti-static bag it came in, being careful not to touch the connectors on the back of the module. Place the module in the cardboard shipping container.
- Step 5. Take the new module out of the anti-static bag, being careful not to touch the connectors on the back of the module.
- Step 6. Insert the module into the desired slot in the rack. Use a screwdriver to secure the module into the slot.
- Step 7. Attach the field terminal connector (M/N 57C374) to the mating half on the module. Make certain that the connector keys are oriented correctly and that the connector is the proper one for this module (see step 6 in 3.2 Initial Installation). Use a screwdriver to secure the connector to the module.
- Step 8. Turn on power to the rack.

value	±5V	±8V	±10V	4-20 ma
4095	+5.0V	+8.0V	+10.0V	20 ma
2047	+2.5V	+4.0V	+5.0V	12 ma
0	0.0V	0.0V	0.0V	4 ma
-2047	-2.5V	-4.0V	-5.0V	0 ma
-4095	-5.0V	-8.0V	-10.0V	0 ma

Table 1

**WARNING**

BE CAREFUL WHEN WRITING TO THE OUTPUTS TO INSURE THAT NO UNEXPECTED MACHINE MOTION WILL RESULT. FAILURE TO OBSERVE THIS PRECAUTION COULD RESULT IN BODILY INJURY OR DAMAGE TO EQUIPMENT.

# 4.0 PROGRAMMING

This section describes how the data is organized in the module and provides examples of how the module is accessed by the application software. For more detailed information, refer to DCS 5000 Enhanced BASIC Language Instruction Manual (J-3600) or AutoMax Enhanced Basic Language Instruction Manual (J-3675).

## 4.1 Register Organization

The data in the module is organized as four 16-bit registers, one for each D/A converter channel. The data in each register is treated as a single precision integer limited to values in the range of +4095 through -4095. Bit 15 is the sign bit and bits 1-14 are the 2's complement data value. Refer to figure 4.1.

15	14	13	12	11	10	9	8	7	6	5	4	3	2	1	0
register 0	S	S	S												-
register 1	S	S	S	S											-
register 2	S	S	S	S	S										-
register 3	S	S	S	S	S	S									-

S = sign bit  
- = not used

Figure 4.1 - Organization of Register Bits

## 4.2 Configuration

Before any application programs can be written, it is necessary to configure, or set, the definitions of system-wide variables, i.e. those that must be globally accessible to all tasks. For DCS 5000 and AutoMax Version 2.1 and earlier, you define system-wide variables by writing a Configuration task. For AutoMax Version 3.0 and later, you define system-wide variables using the AutoMax Programming Executive. After these variables are defined, you can generate the configuration file automatically, which eliminates the requirement to write a configuration task for the rack. If you are using AutoMax Version 2.1 or earlier, refer to Appendix E for examples that show how to define variables in the configuration task. If you are using AutoMax Version 3.0 or later, see the AutoMax Programming Executive (J-3750) for information about configuring variables.

## 4.3 Reading And Writing Data In Application Tasks

In order for an output module to be referenced by application software, it is first necessary to assign symbolic names to the physical hardware. In AutoMax Version 2.1 and earlier, this is accomplished by either IODEF or RIODDF statements in the configuration task. In AutoMax Version 3.0 and later, you assign symbolic names using the Programming Executive.

Each application program that references the symbolic names assigned to the module must declare those names COMMON. The frequency with which tasks, or application programs, read their inputs and write their outputs depends on the language being used. Ladder logic and control block tasks read inputs once at the beginning of each scan and write outputs once at the end of scan. BASIC tasks read an input and write an output for each reference throughout the scan.

### 4.3.1

#### BASIC Task Example

```
2000 COMMON DISPLAY%
3500 i
5000 DISPLAY% = -2048
5500 i
6000 END

The symbolic name DISPLAY% references the analog output
channel.
```

### 4.3.2

#### Control Block Task Example

```
2400 COMMON DISPLAY%
3500 i
5000 CALL INVERTER( INPUT=2048, &
      OUTPUT=DISPLAY%)
5500 i
6000 END

The symbolic name DISPLAY% references the analog output
channel.
```

## 4.4

### Restrictions

#### 4.4.1

##### Data Limitations

Register bit 0 is not connected to the D/A converter. Writing to it will have no effect on the analog output value. When the data is read back, bit 0 will always return 0.

Register bits 12, 13, and 14 are also not connected to the D/A converter. If you expect that the digital value to be written to an output will exceed the range  $\pm 4095$ , place a software limit on the value before writing it to the analog output. Otherwise, if a value greater than  $\pm 4095$  is written to the analog output, the output will be the analog value proportional to the value of bits 1-11 and the sign bit 15.

## 5.0

# DIAGNOSTICS AND TROUBLESHOOTING

This section explains how to troubleshoot the module and field connections.

### 5.1

#### Incorrect Data

**Problem:** The output is either always off, always on, or different than expected. The possible causes of this are a module in the wrong slot, a malfunctioning module, or a programming error. It is also possible that the output is either not wired or wired to the wrong device. Use the following procedure to isolate the problem:

**Step 1.** Verify that the output module is in the correct slot and that the I/O definitions are correct.

Refer to figure 3.3. Verify that the slot number being referenced agrees with the slot number defined in the configuration task. For this module, the register number is always zero. Verify that the register number of the output module agrees with the D/A channel number (0-3).

For remote I/O installations, also verify that the master slot and drop number are defined correctly.

**Step 2.** Verify that the isolated power supplies are working.

Make certain that the four LEDs on the module faceplate are lit. If any of them are not lit, the module is malfunctioning.

**Step 3.** Verify that the terminal board is wired correctly.

Confirm that all connections at the terminal strip are tight. Verify that each of the analog output channels is wired to the correct device and that the jumpers on the terminal strip (if required) are connected. Refer to figures 3.1 and 3.2.

**Step 4.** Verify that the module can be accessed.

Connect the programming terminal to the system and run the Resource Software.

Stop all programs that may be running.

Connect a voltmeter to the voltage output of each channel being checked. Use the I/O MONITOR function and write the values in table 1 to the channel being investigated.

The voltmeter should read the voltages listed in table 1. If it does, the problem lies in the user application program (proceed to step 7).

If the values exceed the accuracy limit, the offset and gain adjustment are not correct and the module is malfunctioning.

**WARNING**  
**BE CAREFUL WHEN WRITING TO THE OUTPUTS TO INSURE THAT NO UNEXPECTED MACHINE MOTION WILL RESULT. FAILURE TO OBSERVE THIS PRECAUTION COULD RESULT IN BODILY INJURY OR DAMAGE TO EQUIPMENT.**

Step 5. Verify that the external field device(s) meet module specifications.

To test voltage outputs, remove the wires for the field devices from the terminal strip and repeat the test in step 4. If the voltmeter now reads the correct values, either the module is malfunctioning or the output device impedance is too low and the current limit feature is preventing the channel from outputting the proper voltage.

Verify the hardware functionality by systematically swapping out modules. After each swap, if the problem is not corrected, replace the original module before swapping out the next module.

To test 4-20 ma current outputs, remove the connector from the face of the module. Connect a voltmeter across the terminal strip connections that are wired to the load and verify that the voltage is within specifications.

Next, connect a current meter across the terminal strip connections and verify that the current is approximately 20 ma. If these tests are not successful, the problem lies in the field wiring or the external device.

Check the cable for continuity between the faceplate connector and the terminal strip. Remember to replace any wires or connectors that have to be removed. Verify that the hardware is working correctly.

Step 6.

Verify the hardware functionality by systematically swapping out modules. After each swap, if the problem is not corrected, replace the original module before swapping out the next module.

- To test local I/O, first replace the output module. Next, replace the processor module (s). If the problem persists, take all of the modules out of the backplane except one processor module and the output module. If the problem is now corrected, one of the other modules in the rack is malfunctioning. Reconnect the other modules one at a time until the problem reappears. If none of these tests reveals the problem, replace the backplane.
- To test remote I/O, first verify that the remote I/O system is communicating with the drop that contains the output module being tested. Next, determine whether the output module is the only module in the rack that is not working. If more than one module is not working correctly, the problem most likely lies in the remote I/O system. If the problem does not lie in the system, it probably involves the remote rack.

## 5.2

### Bus Error

- To test the remote rack, first replace the output module. Next, replace the slave remote I/O module. If the problem persists, take all of the modules out of the remote backplane except the slave remote I/O module and the output module. If the problem is now corrected, one of the other modules in the rack is malfunctioning. Reconnect the other modules one at a time until the problem reappears. If the problem proves to be neither in the remote I/O system nor in the remote rack, try replacing the backplane.
- Step 7. Verify that the user application program is correct. If none of the above steps has corrected the problem, verify that the application program that uses the symbolic names assigned to the module has defined those names as COMMON. Verify that the symbolic name in question is being referenced in the application program. This can be done indirectly by monitoring the name with the VARIABLE MONITOR function in the Resource software.
- Problem: A "31" or "51" through "58" appears on the processor module's LED. This error message indicates that there was a bus error when the system attempted to access the module. The possible causes of this error are a missing module, a module in the wrong slot, or a malfunctioning module. Refer to the DCS Processor Module Instruction Manual (J-3635) or AutoMax Processor Module Instruction Manual (J-3650) for more information. Use the following procedure to isolate a bus error:
  - Step 1. Verify that the output module is in the correct slot and that the I/O definitions are correct.
  - Refer to figure 3.3. Verify that the slot number being referenced agrees with the slot number defined in the configuration task. Verify that the register number of the output module agrees with the D/A channel number (0-3).
  - For remote I/O installations, also verify that the master slot and remote drop number are defined correctly.
  - Step 2. Verify that the module can be accessed. Connect the programming terminal to the system and run the Resource Software. Stop all programs that may be running. Use the I/O MONITOR function to display each of the channels. If the programmer is able to monitor the outputs, then try to write zeros to the outputs.

**WARNING**  
**BE CAREFUL WHEN WRITING TO THE OUTPUTS TO INSURE THAT NO UNEXPECTED MACHINE MOTION WILL RESULT. FAILURE TO OBSERVE THIS PRECAUTION COULD RESULT IN BODILY INJURY OR DAMAGE TO EQUIPMENT.**

Step 3. If the programmer is able to read and write to the output module, the problem lies in the application software and you need to refer to step 1 again.  
If the programmer cannot read and write the outputs, the problem lies in the hardware (proceed to step 3).  
Verify that the hardware is working correctly.  
Verify the hardware functionality by systematically swapping out the output module, the processor module(s), and the backplane. After each swap, if the problem is not corrected, replace the original item before swapping out the next item.  
For remote I/O installations, systematically swap out the output module, the slave remote module, and the backplane. After each swap, if the problem is not corrected, replace the original item before swapping out the next item.

# Appendix A

## Technical Specifications

### Ambient Conditions

- Storage temperature: -40° C - 85° C
- Operating temperature: 0° C - 60° C
- Humidity: 5-90% non-condensing

### Maximum Module Power Dissipation

- 13.7 Watts

### Dimensions

- Height: 11.75 inches
- Width: 1.25 inches
- Depth: 7.375 inches

### System Power Requirements

- +5 volts: 2750 ma
- +12 volts: 55 ma
- -12 volts: 5 ma

### Output Circuit

- Number of channels: 4
- Output ranges:  $\pm 5$  volts, 10 ma max  
 $\pm 8$  volts, 10 ma max  
 $\pm 10$  volts, 10 ma max  
4-20 ma, external power
- Resolution: voltage outputs – 12 bits including sign  
4-20 ma – 11 bits (sign bit always 0)
- Accuracy:  $\pm 0.10\%$  of full scale (voltage output)  
 $\pm 0.15\%$  of full scale (current output)
- Output Filter:  $\pm 5$  Volts - first order 200 Hz low pass  
 $\pm 8$  Volts - first order 125 Hz low pass  
 $\pm 10$  Volts - first order 100 Hz low pass  
4-20 ma - none
- Voltage outputs short-circuit protected
- Each channel individually isolated
- 2500 volt isolation between logic common and outputs





# Appendix B

## Module Block Diagram

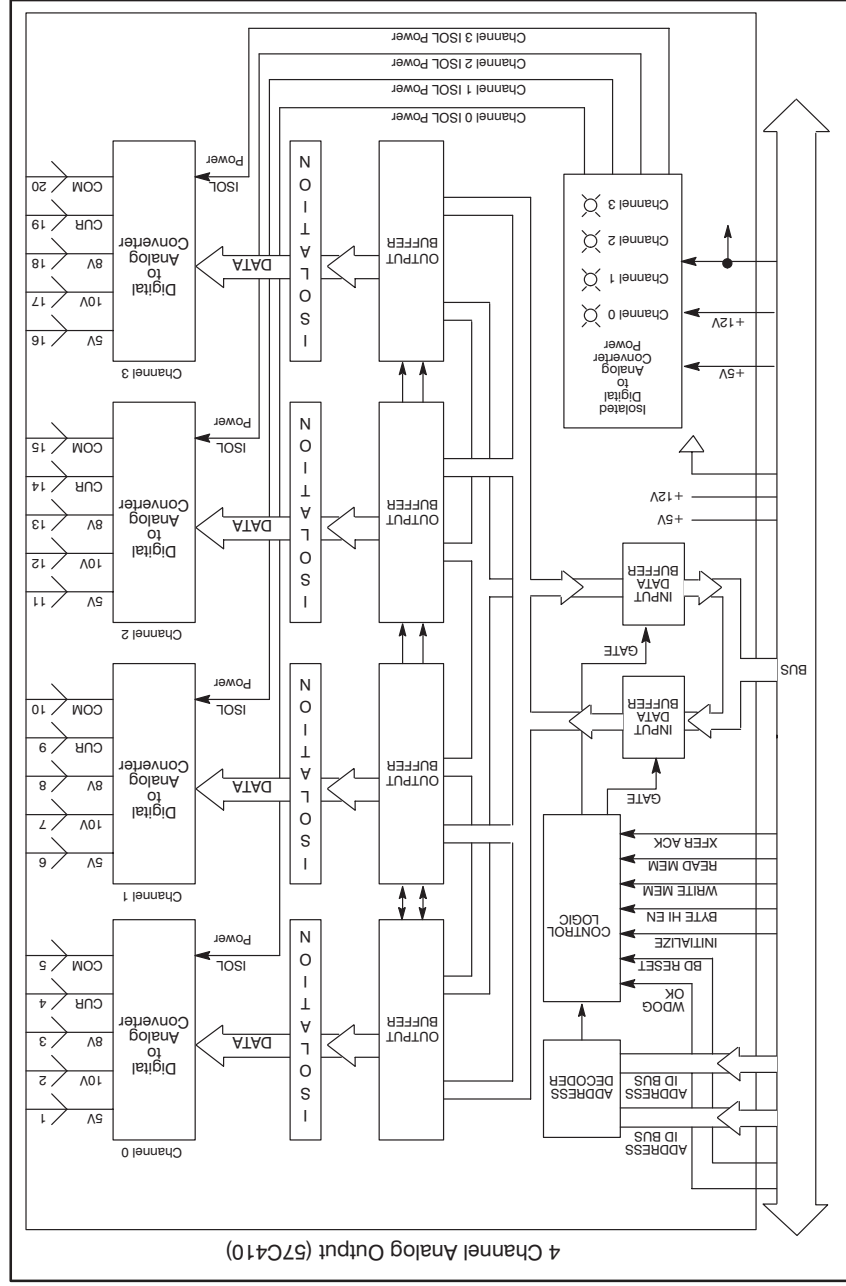



# Appendix C

## Field Connections

Channel	Pin No.	Function
0	1	5 volt jumper
	2	voltage output
	3	8 volt jumper
	4	current output
	5	common
1	6	5 volt jumper
	7	voltage output
	8	8 volt jumper
	9	current output
	10	common
2	11	5 volt jumper
	12	voltage output
	13	8 volt jumper
	14	current output
	15	common
3	16	5 volt jumper
	17	voltage output
	18	8 volt jumper
	19	current output
	20	common



## Appendix D

### Related Components

57C374 – Terminal Strip/Cable Assembly

This assembly consists of a terminal strip, cable, and mating connector. It is used to connect field signals to the faceplate of the output module.

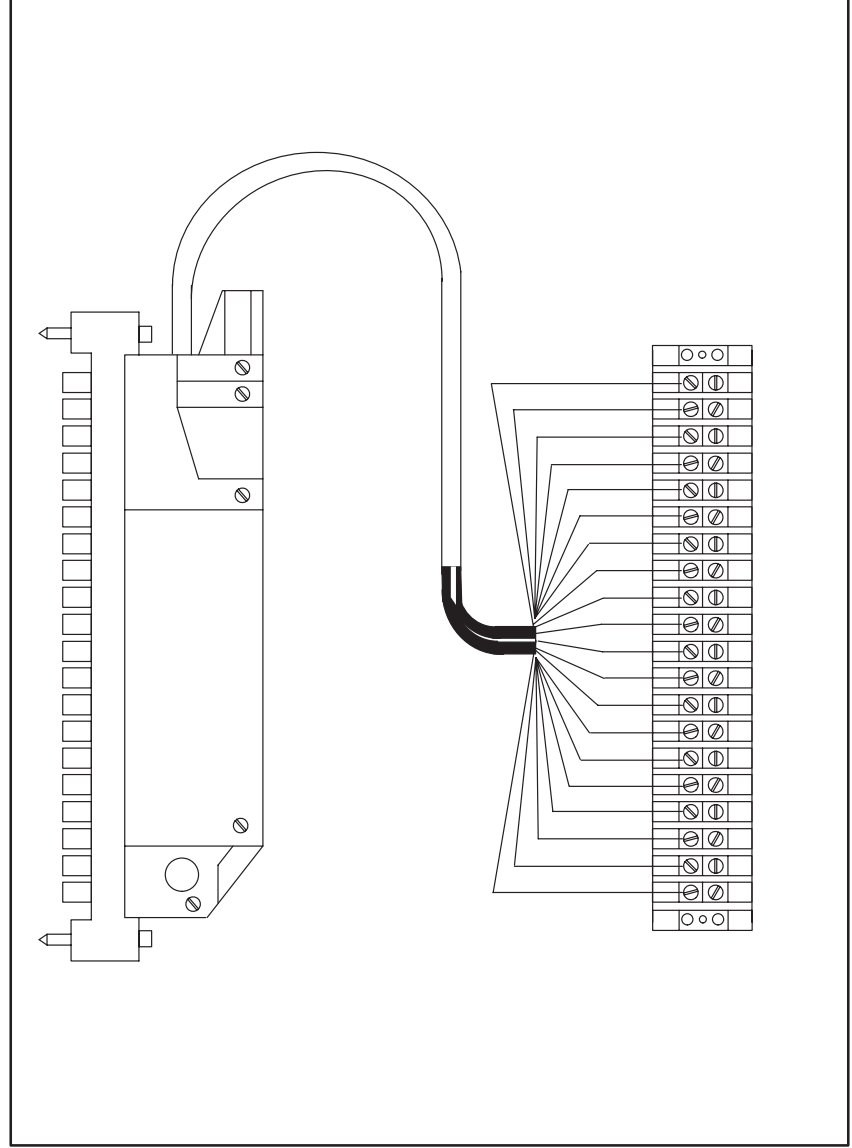



# Appendix E

## Defining Variables in the Configuration Task

### Local I/O Definition

This section describes how to configure the output module when it is located in the same rack as the processor module that is referencing it (i.e., the local rack). Refer to the figure below. Note that this procedure is used only if you are using the AutoMax Programming Executive software version 2.1 or earlier.

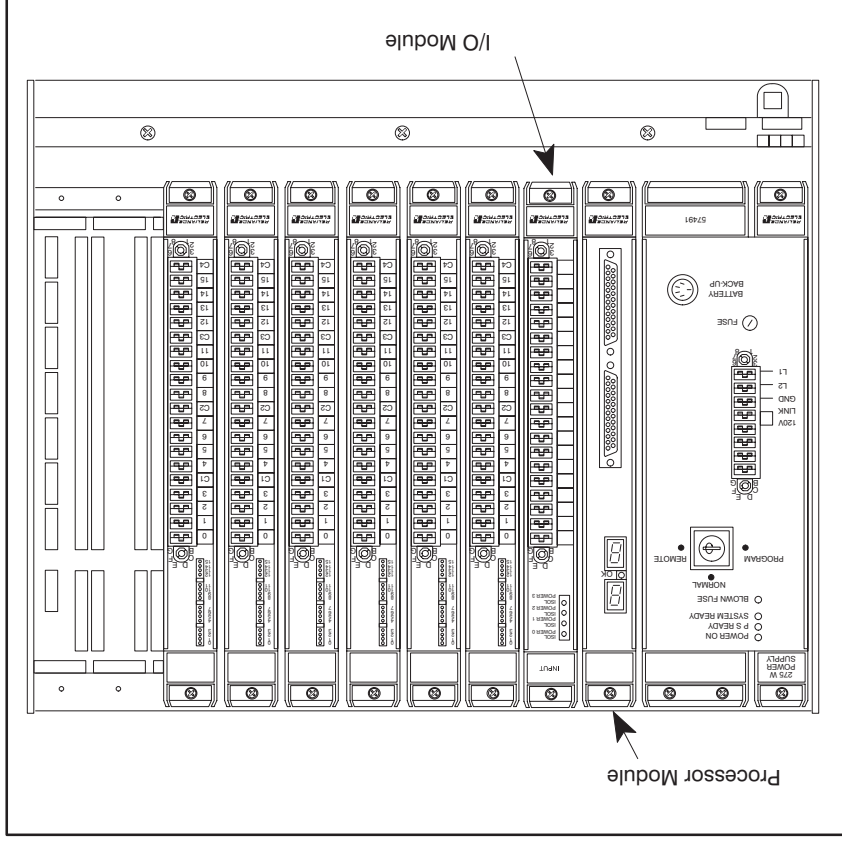

Module in a Local Rack



## Register Reference

One statement is required in the configuration task for each channel that will be used. The symbolic name of each register should be as meaningful as possible:

```
nnnn IODEF SYMBOLIC_NAME% [ SLOT=s, REGISTER=r]
```

where:

nnnnn - BASIC statement number. This number may range from 1-32767.

SYMBOLIC\_NAME% - A symbolic name chosen by the user and ending with (%). This indicates an integer data type.

SLOT - Slot number that the module is plugged into. This number may range

from 0-15.

REGISTER - The register number corresponding to the analog output channel

(0-3).

### Example Of Local I/O Definition

The following statement assigns the symbolic name DISPLAY% to analog output channel number 2 on the output module located in slot 4:

```
1020 IODEF POSITION% [ SLOT=4, REGISTER=2]
```

### Remote I/O Definition

This section describes how to configure the module when it is located in a rack that is remote from the processor module referencing it. Refer to the figure below.

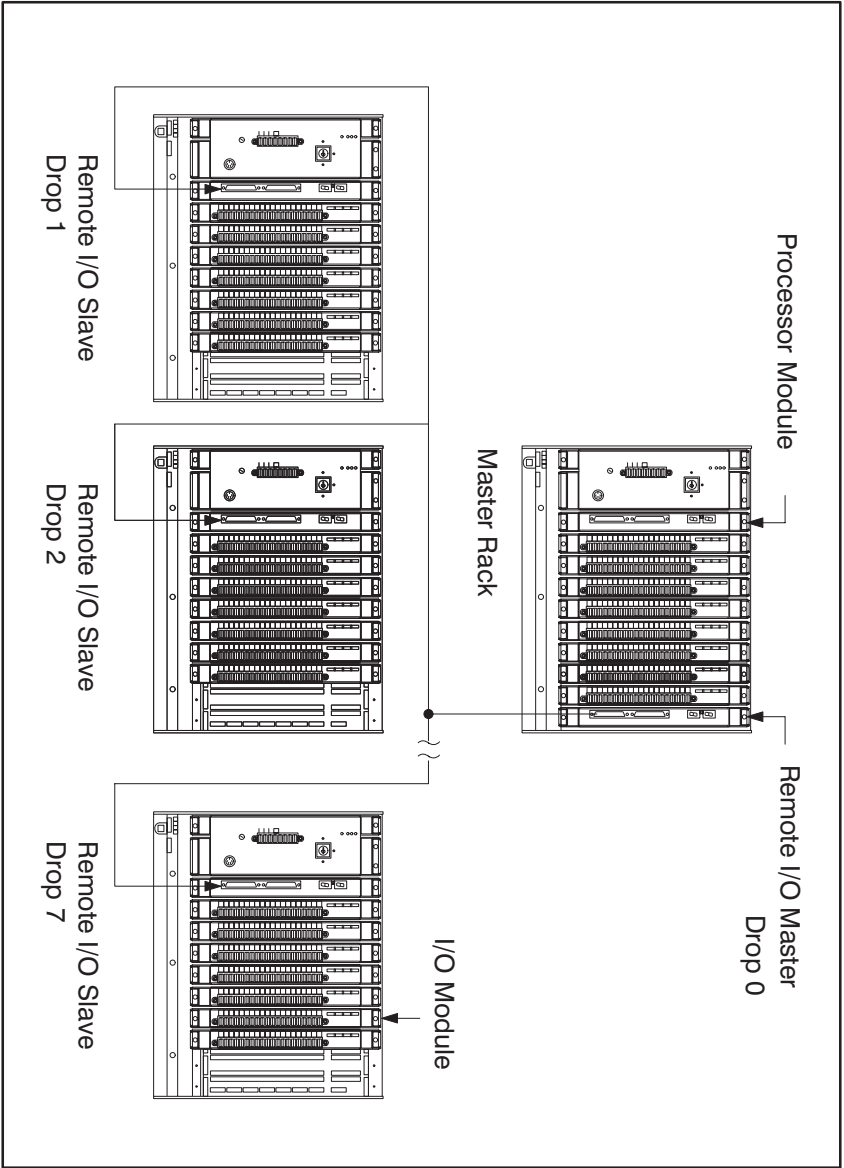

Module in a Remote Rack

## Register Reference

One statement is required in the configuration task for each channel that will be used. The symbolic name of each channel should be as meaningful as possible:

```
nnnn RIODEF SYMBOLIC_NAME% [ MASTER_SLOT=m,
DROP=d, SLOT=s, REGISTER=r ]
```

where:

nnnn - BASIC statement number. This number may range from 1-32767.

SYMBOLIC\_NAME% - A symbolic name chosen by the user and ending with (%). This indicates an integer data type.

MASTER\_SLOT - Slot number that the master remote I/O module is plugged into. This number may range from 0-15.

REGISTER - The register number corresponding to the analog output channel (0-3).

DROP - Drop number of the slave remote I/O module that is in the same rack as the output module. This number may range from 0-7.

SLOT - Slot number that the module is plugged into. This number may range from 0-15.

REGISTER - The register number corresponding to the analog output channel (0-3).

## Example of Remote I/O Definition

The following statement assigns the symbolic name LEVEL% to analog output channel number 1 on the output module located in slot 4 of remote I/O drop 3. This remote drop is connected to the remote I/O system whose master is located in slot 15 in the master rack:

```
1020 RIODEF LEVEL% [ MASTER_SLOT=15, DROP=3,
SLOT=4, REGISTER=1 ]
```



**For additional information**

1 Allen-Bradley Drive  
Mayfield Heights, Ohio 44124 USA  
Tel: (800) 241-2886 or (440) 646-3599  
<http://www.reliance.com/automax>

**[www.rockwellautomation.com](http://www.rockwellautomation.com)**

**Corporate Headquarters**

Rockwell Automation, 777 East Wisconsin Avenue, Suite 1400, Milwaukee, WI, 53202-5302 USA, Tel: (1) 414.212.5200, Fax: (1) 414.212.5201

**Headquarters for Allen-Bradley Products, Rockwell Software Products and Global Manufacturing Solutions**

Americas: Rockwell Automation, 1201 South Second Street, Milwaukee, WI 53204-2496 USA, Tel: (1) 414.382.2000, Fax: (1) 414.382.4444  
Europe/Middle East/Africa: Rockwell Automation SA/NV, Vorstlaan/Boulevard du Souverain 36, 1170 Brussels, Belgium, Tel: (32) 2 663 0600, Fax: (32) 2 663 0640  
Asia Pacific: Rockwell Automation, 27/F Citicorp Centre, 18 Whitfield Road, Causeway Bay, Hong Kong, Tel: (852) 2887 4788, Fax: (852) 2508 1846

**Headquarters for Dodge and Reliance Electric Products**

Americas: Rockwell Automation, 6040 Ponders Court, Greenville, SC 29615-4617 USA, Tel: (1) 864.297.4800, Fax: (1) 864.281.2433  
Europe/Middle East/Africa: Rockwell Automation, Brihlstraße 22, D-74834 Ertal-Dallau, Germany, Tel: (49) 6261 9410, Fax: (49) 6261 17741  
Asia Pacific: Rockwell Automation, 55 Newton Road, #11-01/02 Revenue House, Singapore 307987, Tel: (65) 6356-9077, Fax: (65) 6356-9011

Publication J-3631-1 - June 1991

Copyright © 2002 Rockwell Automation, Inc.. All rights reserved. Printed in U.S.A.



## Artisan Technology Group is your source for quality new and certified-used/pre-owned equipment

- FAST SHIPPING AND DELIVERY
- TENS OF THOUSANDS OF IN-STOCK ITEMS
- EQUIPMENT DEMOS
- HUNDREDS OF MANUFACTURERS SUPPORTED
- LEASING/MONTHLY RENTALS
- ITAR CERTIFIED SECURE ASSET SOLUTIONS

### SERVICE CENTER REPAIRS

Experienced engineers and technicians on staff at our full-service, in-house repair center

### *InstraView*<sup>SM</sup> REMOTE INSPECTION

Remotely inspect equipment before purchasing with our interactive website at [www.instraview.com](http://www.instraview.com) ↗

### WE BUY USED EQUIPMENT

Sell your excess, underutilized, and idle used equipment. We also offer credit for buy-backs and trade-ins. [www.artisanng.com/WeBuyEquipment](http://www.artisanng.com/WeBuyEquipment) ↗

### LOOKING FOR MORE INFORMATION?

Visit us on the web at [www.artisanng.com](http://www.artisanng.com) ↗ for more information on price quotations, drivers, technical specifications, manuals, and documentation

**Contact us:** (888) 88-SOURCE | [sales@artisanng.com](mailto:sales@artisanng.com) | [www.artisanng.com](http://www.artisanng.com)