



Artisan Technology Group is your source for quality new and certified-used/pre-owned equipment

- FAST SHIPPING AND DELIVERY
- TENS OF THOUSANDS OF IN-STOCK ITEMS
- EQUIPMENT DEMOS
- HUNDREDS OF MANUFACTURERS SUPPORTED
- LEASING/MONTHLY RENTALS
- ITAR CERTIFIED SECURE ASSET SOLUTIONS

SERVICE CENTER REPAIRS

Experienced engineers and technicians on staff at our full-service, in-house repair center

*InstraView*SM REMOTE INSPECTION

Remotely inspect equipment before purchasing with our interactive website at www.instraview.com ↗

WE BUY USED EQUIPMENT

Sell your excess, underutilized, and idle used equipment. We also offer credit for buy-backs and trade-ins. www.artisanng.com/WeBuyEquipment ↗

LOOKING FOR MORE INFORMATION?

Visit us on the web at www.artisanng.com ↗ for more information on price quotations, drivers, technical specifications, manuals, and documentation

Contact us: (888) 88-SOURCE | sales@artisanng.com | www.artisanng.com



32-Bit Expansion

Complete Expansion Units and Components

Features

- Easy installation and configuration
- Plug-n-go operation – no software required
- 7 or 13 slots on a separate backplane
- Supports full length PCI cards
- Ample cooling to keep your PCI cards running cool
- Independent operation of host bus and expansion buses
- Stand-alone mini-tower and rackmount chassis available
- Low latency and high throughput for maximum performance

Limited by the number of PCI slots in your computer?

GE Intelligent Platforms makes it easy and cost effective to add PCI slots so you can expand your computer's functionality by adding more PCI cards. Because our expansion products conform to the PCI to PCI Bridge Architecture Specification, no additional software drivers are required for cards installed in the expansion unit. Complete expansion systems, in a variety of configurations, and expansion components are available.

For applications requiring 64-bit expansion or chassis separation greater than 4 feet.

Omnispan™ PCI 64-bit expansion systems and components are available for applications requiring 64-bit PCI or CompactPCI expansion or chassis separation greater than 4 feet. Omnispan 64-bit/33 MHz PCI expansion kits provide 7 additional PCI slots to PCI system. Omnispan components provide additional slots for CompactPCI host systems. Featuring 266 MB/s throughput and low latency, Omnispan provides true real-time performance. Plus, Omnispan supports cable lengths up to 5 meters.

Omnispan is available as a complete kit or as individual components. Available components include:

- Host cards: PCI and CompactPCI
- Backplanes: PCI
- Backplane controller: CompactPCI
- Cables: lengths up to 5 meter



32-Bit Expansion Units and Components

Specifications

Complete Expansion Units

2123A ATX

- 13-slot rackmount
- ATX
- 420W power supply: 5V/3.3V
- Cooling fans: one 116 CFM & one 44 CFM P/S

2131 ATX

- 7-slot mini-tower
- ATX
- 300W power supply: 5V/3.3V
- Two 3.5-inch and two 5-inch expansion bays
- Cooling fans: one 27.5 CFM

2132 ATX

- 7-slot rackmount
- ATX
- 300W power supply: 5V/3.3V
- Cooling fans: two 42. CFM

Host Cards

- Supports cable lengths up to 4' (1.2m)
- Throughput up to 132 MB/s
- 32-bit / 33 MHz
- Draws 0.5A at +5V maximum

200-2 PCI

- Installs in a 32-bit or 64-bit +5V or +3.3V master capable PCI slot

56040-101 PCI

- 6/6 RoHS version of the 200-2

201-2 PMC

- PCI card with PMC connectors
- Installs in a 32-bit or 64-bit +5V master capable PMC connector

202-2 CompactPCI

- Installs in a 32-bit or 64-bit +5V master capable cPCI slot

200-2A Remote Power-up PCI

- Used only with Remote Power-up backplane controller card and backplane or rackmount enclosure

Backplane Controller Cards

210-2 PCI

- Use with any 32-bit PCI20x-2 host card and any non-ATX backplane
- Draws 0.5A at +5V maximum

56040-102 PCI

- 6/6 RoHS version of the 210-2 212-2 CompactPCI
- Use with any 32-bit PC 20x-2 host card, any standard

cPCI backplane, and any cPCI enclosure

- Draws 0.5A at +5V maximum

210-2A Remote Power-up PCI

- Used only with Remote Power-up host card and backplane or rackmount enclosure

Backplanes: ATX

- Single PCI bus
- 32-bit PCI slots support +5V PCI cards

23-530-2 Seven-slot ATX

- Integrated backplane controller functions
- Compatible with any 32-bit 20x-2 host card
- Dimensions (WxD): 11.2 x 7.2 (inches); 28.45 x 18.29 (cm)

24-500-2A Fourteen-slot ATX

- Four PCI buses
- Compatible with Remote Power-up host card and backplane controller
- Dimensions (WxD): 12.35 x 7.75 (inches); 31.37 x 19.69 (cm)

Backplanes: Non-ATX

- Requires 210-2 PCI backplane controller card
- Compatible with any 32-bit 20x-2 host card
- 32-bit PCI slots support +5V PCI cards

23-500-2 Eight-slot Non-ATX

- Two PCI buses
- Dimensions (WxD): 8.6 x 7.2 (inches); 21.84 x 18.29 (cm)

Cable (Round 68-pin)

- Use with all 32-bit expansion products
- 2-foot (.6m): 10-202
- 4-foot (1.2m): 10-204



Enclosures: ATX

- Single PCI bus

240-2-201A 13-slot Rackmount

- Compatible with 200-2A PCI Remote Power-up host card and 210-2A backplane controller card
- 420W power supply with provision for +5V and +3.3V
- Includes 24-500-2A backplane; draws 1.5A at +5V maximum
- Dimensions: 17x6.5x18 (inches); 43.2x16.5x45.7 (cm); Faceplate: 19x7 (inches); 48.26x17.78 (cm)

32-bit System Requirements

PCI Cards Installed In Expansion Unit Slots

- Long or short form factor
- 32/64-bit data and 32/64-bit address capable (all PCI expansion slots operate at 32- bits/33 MHz)
- Comply with PCI Bridge Architecture Specification Rev. 1.2 if applicable
- Comply with PCI Local Bus Specification 2.3

Host Computer

- At least one available PCI slot
- Comply with all PCI bus specifications
- BIOS or boot ROM must recognize up to two levels of PCI bridges for four and seven slot expansion units, and up to three levels for 13-slot units



32-Bit Expansion Units and Components

Features Matrix

Feature	2131 ATX	2132 ATX	2123A ATX
Number of PCI slots 7 7 13	7	7	13
Enclosure type	Mini-tower	19" rackmount	19" rackmount
Color	Pearl-white	Black faceplate	Black faceplate
Cooling fans	1 (27.5 CFM)	2 (42.5 CFM)	1 (116 CFM) 1 (44 CFM)
Expansion bays	2 (3.5") 2 (5.0")	None	None
Dimensions: Inches (WxHxD) cm	9.5x14.25x17.25 24.13x36.2x43.82	17x6.5x18* 43.2x16.5x45.7	17x 6.5x18* 43.2x16.5x45.7
Backplane controller	Integrated	Integrated	210-2A
Maximum total	300W	300W	420W
Combined 3.3V & 5V	160W	160W	220W
+5V maximum	150W	150W	200W
+3.3V maximum	46.2W	46.2W	99W

* Faceplate: 19 x 7 inches (48.26 x 17.78 cm)



32-Bit Expansion Units and Components

Block Diagram

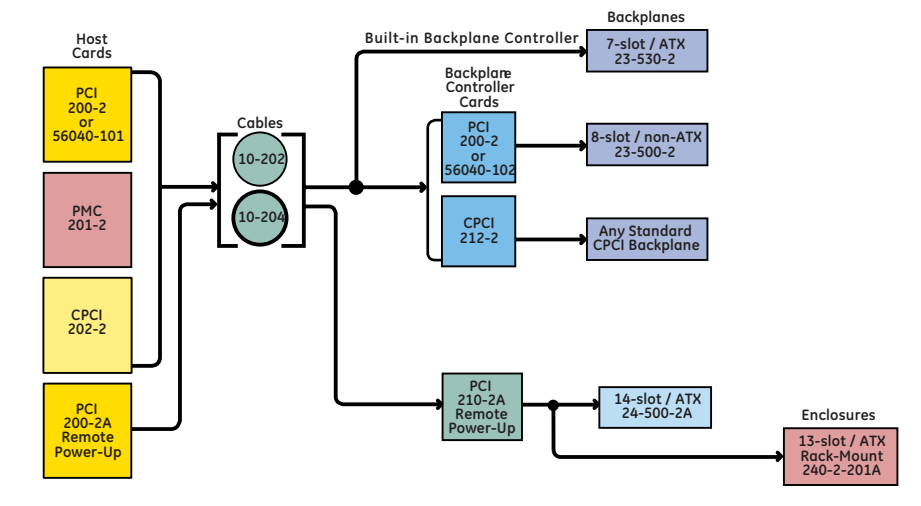

About GE Intelligent Platforms

GE Intelligent Platforms, a General Electric Company (NYSE: GE), is an experienced high-performance technology company and a global provider of hardware, software, services, and expertise in automation and embedded computing. We offer a unique foundation of agile, advanced and ultra-reliable technology that provides customers a sustainable advantage in the industries they serve, including energy, water, consumer packaged goods, government and defense, and telecommunications. GE Intelligent Platforms is a worldwide company headquartered in Charlottesville, VA and is part of GE Home and Business Solutions. For more information, visit www.ge-ip.com.

GE Intelligent Platforms Contact Information

Americas: **1 800 433 2682** or **1 434 978 5100**

Global regional phone numbers are listed by location on our web site at www.ge-ip.com/contact

www.ge-ip.com



©2010 GE Intelligent Platforms, Inc. All rights reserved.
All other brands or names are property of their respective holders.
Specifications are subject to change without notice.

01.10 GFA-916A



Artisan Technology Group is your source for quality new and certified-used/pre-owned equipment

- FAST SHIPPING AND DELIVERY
- TENS OF THOUSANDS OF IN-STOCK ITEMS
- EQUIPMENT DEMOS
- HUNDREDS OF MANUFACTURERS SUPPORTED
- LEASING/MONTHLY RENTALS
- ITAR CERTIFIED SECURE ASSET SOLUTIONS

SERVICE CENTER REPAIRS

Experienced engineers and technicians on staff at our full-service, in-house repair center

*InstraView*SM REMOTE INSPECTION

Remotely inspect equipment before purchasing with our interactive website at www.instraview.com ↗

WE BUY USED EQUIPMENT

Sell your excess, underutilized, and idle used equipment. We also offer credit for buy-backs and trade-ins. www.artisanng.com/WeBuyEquipment ↗

LOOKING FOR MORE INFORMATION?

Visit us on the web at www.artisanng.com ↗ for more information on price quotations, drivers, technical specifications, manuals, and documentation

Contact us: (888) 88-SOURCE | sales@artisanng.com | www.artisanng.com