



## Artisan Technology Group is your source for quality new and certified-used/pre-owned equipment

- FAST SHIPPING AND DELIVERY
- TENS OF THOUSANDS OF IN-STOCK ITEMS
- EQUIPMENT DEMOS
- HUNDREDS OF MANUFACTURERS SUPPORTED
- LEASING/MONTHLY RENTALS
- ITAR CERTIFIED SECURE ASSET SOLUTIONS

### SERVICE CENTER REPAIRS

Experienced engineers and technicians on staff at our full-service, in-house repair center

### *InstraView*<sup>SM</sup> REMOTE INSPECTION

Remotely inspect equipment before purchasing with our interactive website at [www.instraview.com](http://www.instraview.com) ↗

### WE BUY USED EQUIPMENT

Sell your excess, underutilized, and idle used equipment. We also offer credit for buy-backs and trade-ins. [www.artisanng.com/WeBuyEquipment](http://www.artisanng.com/WeBuyEquipment) ↗

### LOOKING FOR MORE INFORMATION?

Visit us on the web at [www.artisanng.com](http://www.artisanng.com) ↗ for more information on price quotations, drivers, technical specifications, manuals, and documentation

**Contact us:** (888) 88-SOURCE | [sales@artisanng.com](mailto:sales@artisanng.com) | [www.artisanng.com](http://www.artisanng.com)

# Modicon TSX Compact

## User Information / Benutzerinformation

### AS-HDTA-200(C)

---

DOK-247 760.26-0298

## 1 Unpacking / Auspacken

Remove the module from its shipping box and check for physical damage. If damage is found, contact your distributor to verify warranty claims.

Baugruppe der Verpackung entnehmen und auf äußere Beschädigung kontrollieren. Falls die Baugruppe beschädigt ist, zur Klärung der Garantieansprüche Kontakt mit Lieferanten aufnehmen.



**Note** The letter "C" in the modules name indicates Conformal Coating.



**Hinweis:** Der Buchstabe "C" im Produktnamen kennzeichnet die Baugruppenträger mit Schutzlackierung.



**GROUPE SCHNEIDER**

■ Merlin Gerin ■ Modicon ■ Square D ■ Telemecanique

## 2 Mounting / Montage

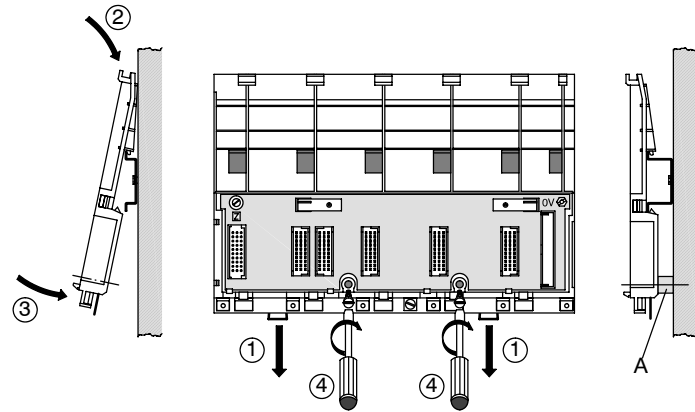

Mount the backplane five steps:

**Step 1**

Pull down the two clips which are located at the bottom of the backplane.

**Step 2**

Place the clip on the rear of the backplane over the top of the top hat rail. Using a 15 mm top hat rail: Before rest the attached bracing elements A flush against the bore holes on the back of the backplane.

**Step 3**

Drop the backplane into place against the mounting surface.

**Step 4**

In addition you can secure the AS-HDTA by using two screws (max. 4 mm  $\emptyset$ ).

Using a 7.5 mm top hat rail (acc. DIN-EN 50 022): ca. 20mm long

Using a 15 mm top hat rail: ca. 25 mm long.

**Step 5**

Push the two clips up into position.

Montieren Sie den Baugruppenträger wie folgt in fünf Schritten:

**Schritt 1**

Ziehen Sie die beiden unterhalb des AS-HDTA angeordneten Klammern herunter.

**Schritt 2**

Hängen Sie den Baugruppenträger ein. Bei 15 mm Hutschienen: Vorher beiliegenden Abstandhalter A an der Rückseite des AS-HDTA zu den Bohrungen bündig einrasten.

**Schritt 3**

Schwenken Sie den Baugruppenträger zur Hutschiene und rasten Sie ihn ein.

**Schritt 4**

Eine zusätzliche Sicherung des Baugruppenträgers ist mit zwei Schrauben möglich (max. 4 mm  $\emptyset$ ). Bei 7.5 mm Hutschienen nach DIN-EN 50 022: ca. 20 mm lang  
Bei 15 mm Hutschienen: ca. 25 mm lang.

**Schritt 5**

Schieben Sie die beiden Klammern in ihre Position zurück.

### 3 Linking AS-HDTA-200 to AS-HDTA-201/ 202 / Koppeln von AS-HDTA-200 und AS-HDTA-201/ 202

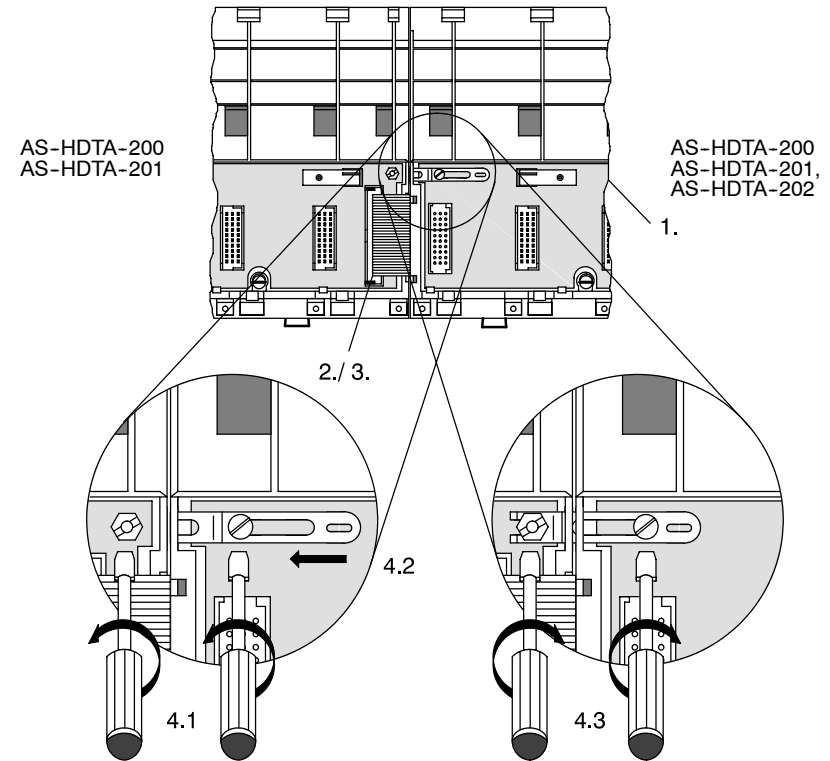

#### Step 1

AS-HDTA-200 and AS-HDTA-201 flush mount on the common top hat rail.

#### Step 2

Unlock and remove the cover of the bus connector.

#### Schritt 1

AS-HDTA-200 u. AS-HDTA-201 auf gemeinsamer Hut-schiene bündig montieren.

#### Schritt 2

Abdeckung Busanschluß entriegeln und abnehmen.

### 4 AS-HDTA-200(C)

**Step 3**

Plug in the bus cable and lock it.

**Step 4.1**

Loosen both screws.

**Step 4.2**

Slide the 0V strap to the left.

**Step 4.3**

Tighten both screws.

**Schritt 3**

Buskabel aufstecken u. verriegeln.

**Schritt 4.1**

Beide Schrauben lösen.

**Schritt 4.2**

0V-Lasche nach links verschieben.

**Schritt 4.3**

Beide Schrauben anziehen.



**Caution** Please take care in step 3 that after having connected the bus cable (ribbon cable or bus extension cable AS-WBXT-201), the locking clip is closed properly (see figure below).



**Achtung:** Sorgen Sie im Schritt 3 dafür, daß nach dem Aufstecken des Buskabels (Flachbandkabel oder Zeilensprungkabel AS-WBXT-201) der Auswurfhebel bündig an der Steckvorrichtung anliegt (siehe folgendes Bild).

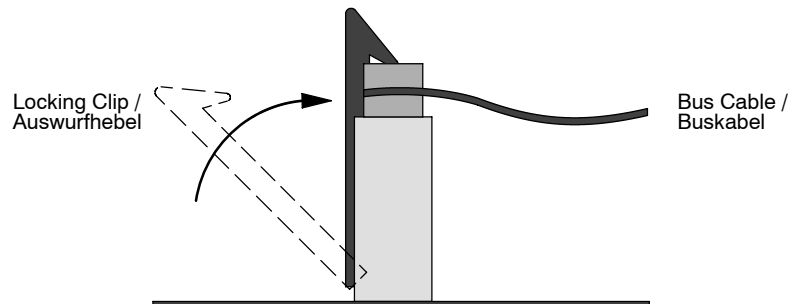

Only in this position a proper bus interconnection is guaranteed.

Nur in dieser Stellung ist eine sichere Kontaktierung der Busverbindung gewährleistet.

## 4 Demounting / Demontage

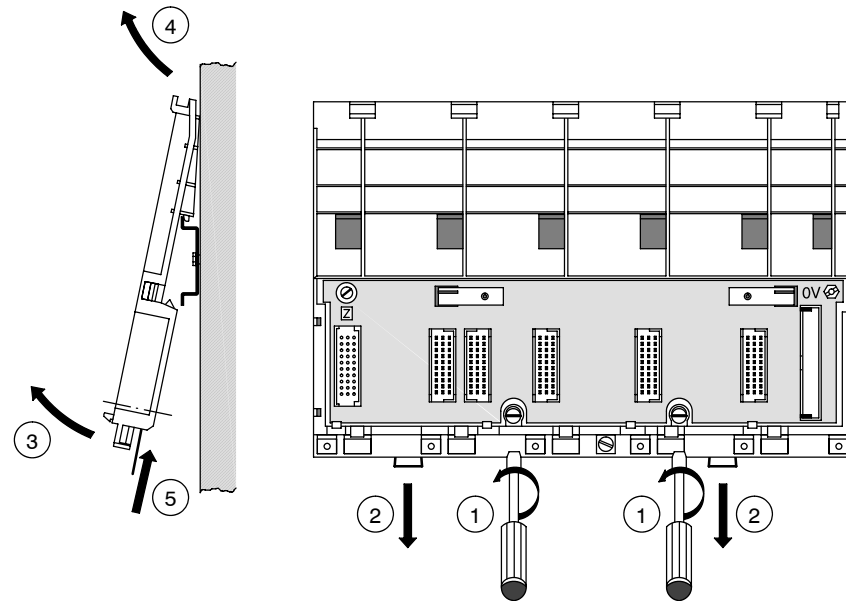

## 5 Further Documentation / Weiterführende Dokumentation

A120  
Programmable Controller  
User Manual  
A91M.12-271 629 EN

A120  
Modulares Automatisierungsgerät  
Benutzerhandbuch  
A91M.12-271 605

984-A120  
Compact Programmable Controller  
User Guide  
A91M.12-701 191 (GM-A984-PCS)

Schneider Automation GmbH  
Steinheimer Str. 117  
D - 63500 Seligenstadt  
Tel.: (49) 61 82 81-0  
Fax: (49) 61 82 81-33 06

Schneider Automation, Inc.  
One High Street  
North Andover, MA 01845, USA  
Tel.: (1) 978 794 0800  
Fax: (1) 978 975 9010

Schneider Automation S. A.  
245, route des Lucioles - BP 147  
F-06903 Sophia-Antipolis  
Tel.: (33) 4 92 96 20 00  
Fax: (33) 4 93 65 37 15

## 6 AS-HDТА-200(C)



## Artisan Technology Group is your source for quality new and certified-used/pre-owned equipment

- FAST SHIPPING AND DELIVERY
- TENS OF THOUSANDS OF IN-STOCK ITEMS
- EQUIPMENT DEMOS
- HUNDREDS OF MANUFACTURERS SUPPORTED
- LEASING/MONTHLY RENTALS
- ITAR CERTIFIED SECURE ASSET SOLUTIONS

### SERVICE CENTER REPAIRS

Experienced engineers and technicians on staff at our full-service, in-house repair center

### *InstraView*<sup>SM</sup> REMOTE INSPECTION

Remotely inspect equipment before purchasing with our interactive website at [www.instraview.com](http://www.instraview.com) ↗

### WE BUY USED EQUIPMENT

Sell your excess, underutilized, and idle used equipment. We also offer credit for buy-backs and trade-ins. [www.artisanng.com/WeBuyEquipment](http://www.artisanng.com/WeBuyEquipment) ↗

### LOOKING FOR MORE INFORMATION?

Visit us on the web at [www.artisanng.com](http://www.artisanng.com) ↗ for more information on price quotations, drivers, technical specifications, manuals, and documentation

**Contact us:** (888) 88-SOURCE | [sales@artisanng.com](mailto:sales@artisanng.com) | [www.artisanng.com](http://www.artisanng.com)