



Artisan Scientific

QUALITY INSTRUMENTATION ... GUARANTEED

Looking for more information?

Visit us on the web at <http://www.artisan-scientific.com> for more information:

- Price Quotations
- Drivers
- Technical Specifications, Manuals and Documentation

Artisan Scientific is Your Source for Quality New and Certified-Used/Pre-owned Equipment

- Tens of Thousands of In-Stock Items
- Hundreds of Manufacturers Supported
- Fast Shipping and Delivery
- Leasing / Monthly Rentals
- Equipment Demos
- Consignment

Service Center Repairs

Experienced Engineers and Technicians on staff in our State-of-the-art Full-Service In-House Service Center Facility

InstraView™ Remote Inspection

Remotely inspect equipment before purchasing with our Innovative InstraView™ website at <http://www.instraview.com>

We buy used equipment! We also offer credit for Buy-Backs and Trade-Ins

Sell your excess, underutilized, and idle used equipment. Contact one of our Customer Service Representatives today!

Talk to a live person: 888-88-SOURCE (888-887-6872) | Contact us by email: sales@artisan-scientific.com | Visit our website: <http://www.artisan-scientific.com>

FOSC ACC Funnel Ribbon Kit Installation Instructions

1. General Product Information

The FOSC ACC Funnel Ribbon Kit provides the ribbon-sized transportation tubes, distributor cap and funnel required to route ribbons from cables into individual transportation tubes for distribution to the splice organizer trays. This kit is used in conjunction with the FOSC ACC Cable Seal Kit.

2. Kit Components

The FOSC ACC Funnel Ribbon kit is composed of these materials:

- 6 transportation tubes
- 1 distributor cap
- 1 distributor funnel
- Installation instructions

3. Funnel Installation

Note: If core of cable is to be moisture-blocked, ignore these instructions and refer to Section 3.5 in the Cable Blocking Installation Instructions included with closures and cable seals that have cable blocking components.

To install a distribution funnel and transportation tubes on ribbon cable ends, follow these steps:

1. Clean the cable and remove the outer cable sheath (remove 70" for a D5 closure, 48" for B2 closures). Remove the aramid and fiber yarns. Remove all but 1" of the metal shield (if present). (Fig. 1)
2. If dual strength members or multiple metallic strength members are present in the cable, cut each strength member 9" from the ring cut. If multiple dielectric strength members are present, cut them off at the sheath ring cut.
3. Cut the central core tube 2-1/2" from the ring cut (1-1/2" beyond the metal shield if present) and remove the excess tube. (Fig. 1)
4. Attach cable end(s) to the FOSC Work Stand with tie wraps.
5. If a metal shield is present in the cable, pry open the overlap and attach the bond clamp to the edge of the shield.
6. Clean the exposed ribbons and stack them in the order in which they appear in the central core tube. Temporarily wrap a piece of vinyl tape around the ribbons about 1" from the tube to help keep the ribbons stacked.
7. Slide the small end of the distributor funnel over the stacked ribbons, and slide it toward the central core tube. Make sure that the ribbons stay properly stacked. Slide the funnel over the central core tube (remove vinyl tape).

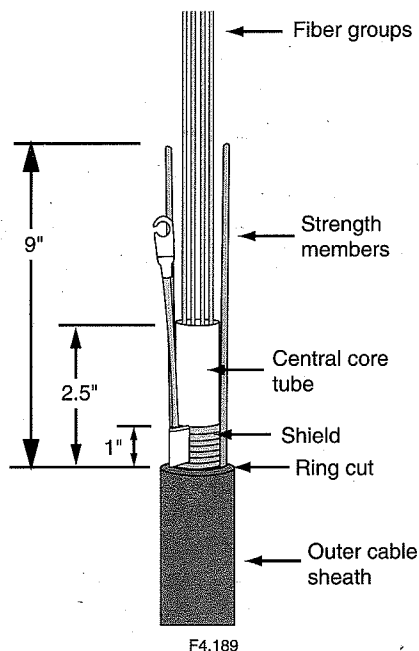

- Place up to four ribbons in each hole of the distributor cap. Each distributor cap hole should contain groups of ribbons adjacent to each other in the cable. (Fig. 2)

Note: If the ribbons are not stacked properly, or if they are twisted, light signals may be attenuated.

- Carefully slide the distributor cap down until it seats in the funnel.
- Place the ribbons from each distributor cap hole into a transportation tube, and slide the tube down into the hole.
- Slide the 4"-long black heat-shrinkable tube (included with cable termination components in cable seal and closure kits) over the transportation tubes and funnel, but under the strength members and bonding wire. The tube should be 1" from the ring cut. If a shield is present in the cable, the tube should be flush with the edge of the shield. (Fig. 3)

- Place a tie wrap around the transportation tubes to hold them in place.

- Begin shrinking the tube with the CV1981 hot-air gun on setting #6. Start at the end of the tube closest to the cable and work towards the transportation tubes. The seal is complete when the tube is completely shrunk around the transportation tubes. (Fig. 4)

- After the tube has cooled, remove the tie wrap from the transportation tubes.

- If multiple metallic strength members are present, twist them into two groups to serve as dual strength members.

- Wrap the bond clamp area and onto the cable with vinyl tape.

- Proceed with cable installation instructions in appropriate cable seal kit.

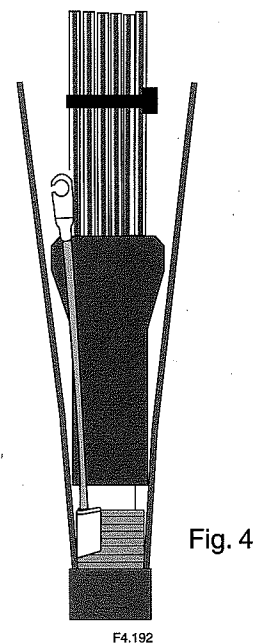
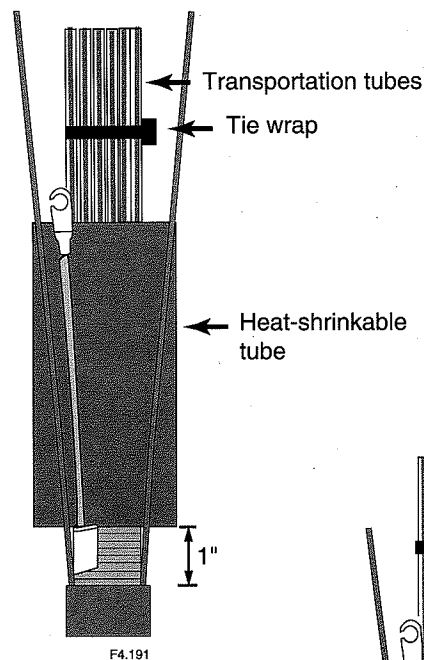
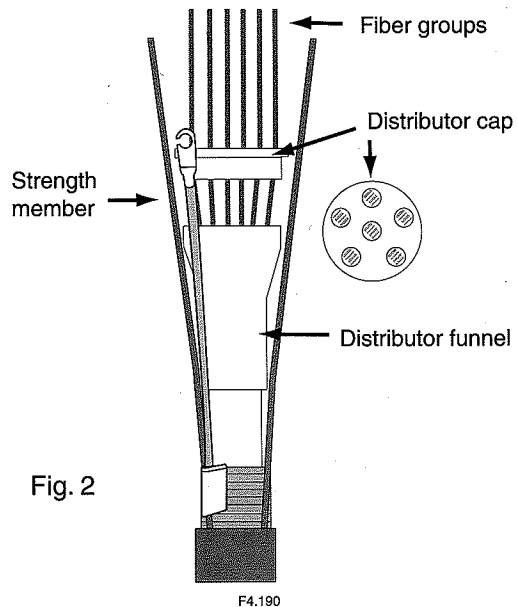



Artisan Scientific

QUALITY INSTRUMENTATION ... GUARANTEED

Looking for more information?

Visit us on the web at <http://www.artisan-scientific.com> for more information:

- Price Quotations
- Drivers
- Technical Specifications, Manuals and Documentation

Artisan Scientific is Your Source for Quality New and Certified-Used/Pre-owned Equipment

- Tens of Thousands of In-Stock Items
- Hundreds of Manufacturers Supported
- Fast Shipping and Delivery
- Leasing / Monthly Rentals
- Equipment Demos
- Consignment

Service Center Repairs

Experienced Engineers and Technicians on staff in our State-of-the-art Full-Service In-House Service Center Facility

InstraView™ Remote Inspection

Remotely inspect equipment before purchasing with our Innovative InstraView™ website at <http://www.instraview.com>

We buy used equipment! We also offer credit for Buy-Backs and Trade-Ins

Sell your excess, underutilized, and idle used equipment. Contact one of our Customer Service Representatives today!

Talk to a live person: 888-88-SOURCE (888-887-6872) | Contact us by email: sales@artisan-scientific.com | Visit our website: <http://www.artisan-scientific.com>