



Artisan Technology Group is your source for quality new and certified-used/pre-owned equipment

- FAST SHIPPING AND DELIVERY
- TENS OF THOUSANDS OF IN-STOCK ITEMS
- EQUIPMENT DEMOS
- HUNDREDS OF MANUFACTURERS SUPPORTED
- LEASING/MONTHLY RENTALS
- ITAR CERTIFIED SECURE ASSET SOLUTIONS

SERVICE CENTER REPAIRS

Experienced engineers and technicians on staff at our full-service, in-house repair center

*InstraView*SM REMOTE INSPECTION

Remotely inspect equipment before purchasing with our interactive website at www.instraview.com ↗

WE BUY USED EQUIPMENT

Sell your excess, underutilized, and idle used equipment. We also offer credit for buy-backs and trade-ins. www.artisanng.com/WeBuyEquipment ↗

LOOKING FOR MORE INFORMATION?

Visit us on the web at www.artisanng.com ↗ for more information on price quotations, drivers, technical specifications, manuals, and documentation

Contact us: (888) 88-SOURCE | sales@artisanng.com | www.artisanng.com



5-PHASE HIGH-TORQUE STEPPING MOTOR AND DRIVER PACKAGE

UPK·W Series

Features	B-62
Product Line	B-66
Standard Type, High-Speed Type.....	B-68
Geared Type.....	B-80
List of Motor and Driver Combinations	B-102
Wiring Diagrams	B-103
Description of Input/Output Signals.....	B-105

The **UPK•W** series is a new generation of compact, high torque, low vibration, 5-phase stepping motor and driver packages.



■ FEATURES

1. Compact Drivers

The **UPK•W** series drivers are only 5.31 inch (135mm) high and therefore keep the installation area small. They also come with a built-in mounting bracket for easy installation.

2. High Torque

The **UPK•W** series is based on the **UPK** series of high-torque, 5-phase stepping motor package, so they have the same high torque. Now devices can be made smaller and more lightweight.

3. Low Vibration

The **UPK•W** series does more than provide higher torque. It is also designed so that the motor produces less vibration, and a new driver has been developed to include a vibration control circuit to dramatically reduce vibration in the mid-speed range (1~5kHz).

4. Low Noise

The motor is designed on a new principle to produce excellent sound performance. The motor components are more rigid and the motor structure has been redesigned to achieve a significant reduction in audible noise.

5. Wide range of power supply voltage

In addition to single-phase 100-115VAC $\pm 15\%$ (50/60 Hz) power input, the product line also has 200-230VAC $\begin{matrix} +10\% \\ -15\% \end{matrix}$ (50/60 Hz) models.

The models with installation dimensions of 1.65inch (42mm) square and the high-speed types only accept single-phase 100-115 VAC input.

6. Standard certified products

These products are certified to meet the world's most common standards. Also, the product has been CE marked according to the low voltage directive. (Certification for some products is pending, so for a list of certified products, see Page D-15.)

■ UPK • W SYSTEM CONFIGURATION

A high-torque 5-phase stepping motor and driver are combined to make high-precision positioning with open loop control possible.

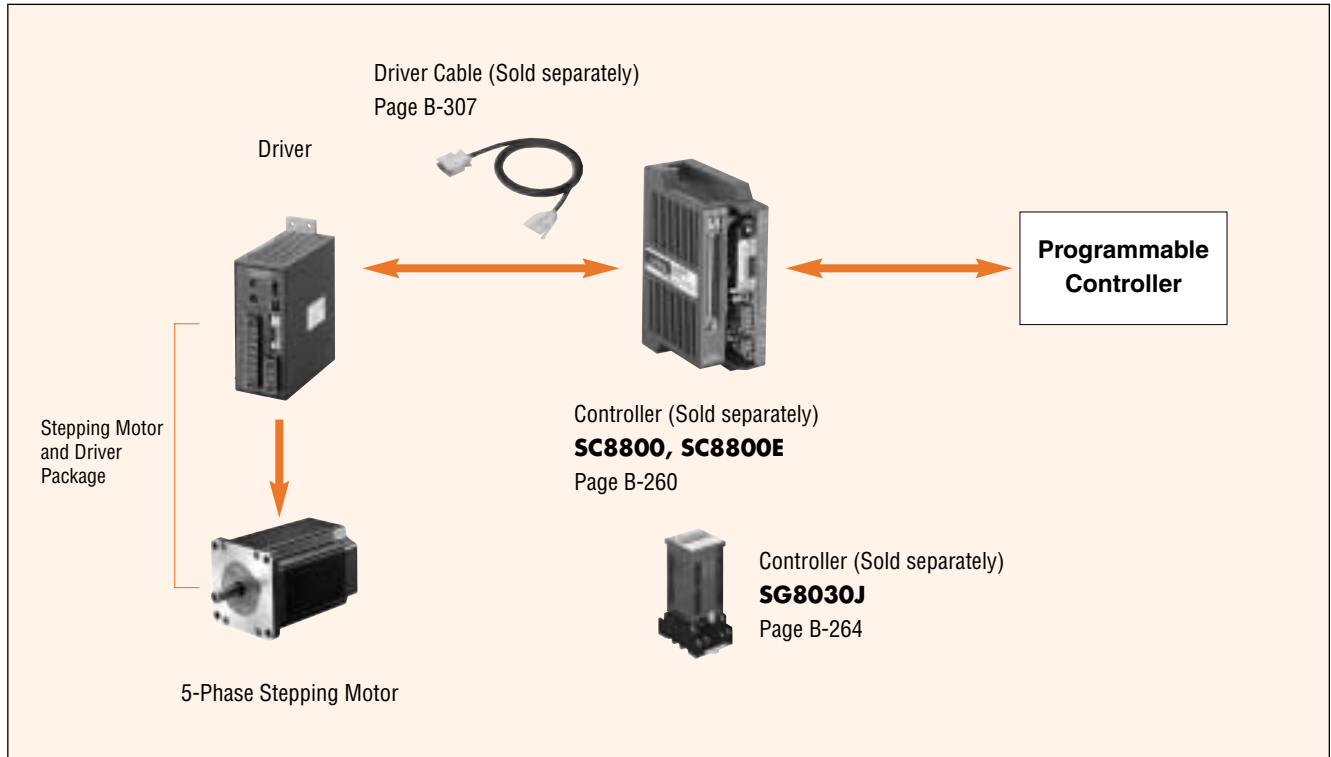

■ ACCESSORIES (Sold separately)

Motor Mounting Bracket
Flexible Coupling
Clean Damper
Extension Cable

- **Motor Mounting Brackets** Page B-298
- **Flexible Couplings** Page B-301
- **Clean Dampers** Page B-300
- **Extension Cables** Page B-306

MC Motor Couplings
 Effective at suppressing motor vibration and improving performance.

16.4 feet (5m), 32.8 feet (10m), 65.6 feet (20m) long

Motor mounting bracket and flexible coupling cannot be fitted on to geared type.

● **Driver Cables** Page B-307
 Flat cable for connecting the driver and controller.

The UPK•W Series Drivers. Designed with User-Friendly Functions.

The UPK•W series has four types of drivers. The functions listed below are common to all types. The drivers shown below are the UDK5114NW2 and the UDK5214NW.

A full range of driver functions are on the front panel.

Driver operating status is visible at a glance

Signal monitor display 1

Easy to confirm I/O signals.

POWER: Power input display
TIM.: Excitation timing output display
O.H.: Overheat output display

Motor operating current adjustment switch
Motor stop current adjustment switch 2

The motor current is easy to adjust with digital switches. No ammeter necessary.

RUN : Can be adjusted the motor running current.
STOP : Can be adjusted the current at the motor standstill.

Pulse input mode switch 3

Switches between 1-pulse input and 2-pulse input.

Step angle switch 4

Switches the motor's step angle.
FULL: 0.72°/step, HALF: 0.36°/step

Automatic current off function switch 5

When the temperature inside the driver reaches 176°F (80°C), this function automatically switches the motor current off. The function can be set and released with this switch.

Power Supply Terminals 6

Drivers are available for use with single-phase 100-115VAC ± 15% (50/60 Hz) and 200-230VAC ± 10%
± 15% (50/60 Hz) models.

Protective Earthing Terminal 7

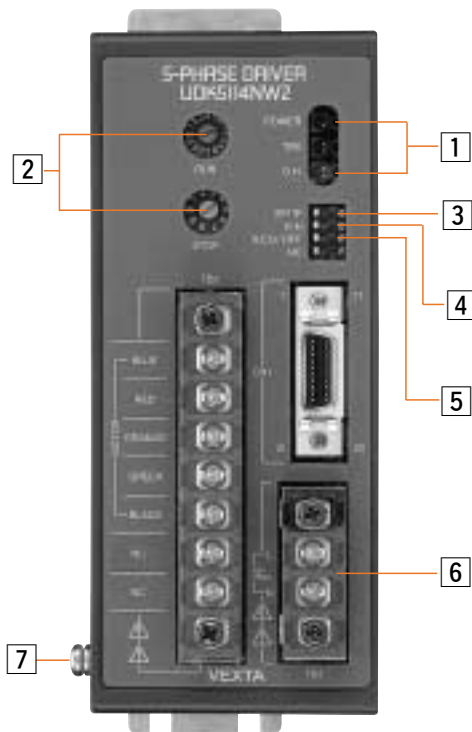

Single-Phase 100-115VAC Input Driver

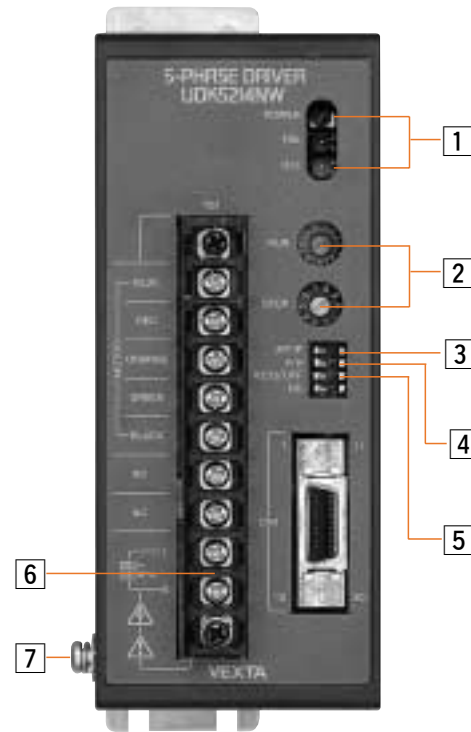

Single-Phase 200-230VAC Input Driver





UPK • W Series Product Line

* T_H : Maximum Holding Torque

Mounting Frame Size inch (mm)

1.65(42)

Standard Type Page B-68	T _H * oz-in (N•m)	18 (0.13)	24.9 (0.18)	33.3 (0.24)	58.3 (0.42)	
	Single-Phase 100V-115VAC Input	UPK543AW UPK543BW	UPK544AW UPK544BW	UPK545AW UPK545BW	UPK564AW2 UPK564BW2	
	Single-Phase 200V-230VAC Input				UPK564AJW UPK564BJW	
High-Speed Type Page B-68	Single-Phase 100V-115VAC Input					
TH Geared Type Page B-80	T _H * lb-in (N•m)	3.03 (0.35)	6.07 (0.7)	8.67 (1)	13 (1.5)	
	Single-Phase 100V-115VAC Input	UPK543AW-T3.6 UPK543BW-T3.6	UPK543AW-T7.2 UPK543BW-T7.2	UPK543AW-T10 UPK543BW-T10	UPK543AW-T20 UPK543BW-T20 UPK543AW-T30 UPK543BW-T30	UPK564AW-T3.6 UPK564BW-T3.6
	Single-Phase 200V-230VAC Input					UPK564AJW-T3.6 UPK564BJW-T3.6
PN Geared Type Page B-80	T _H * lb-in (N•m)					
	Single-Phase 100V-115VAC Input					
	Single-Phase 200V-230VAC Input					

2.36(60)

3.35(85)/3.54(90)

115 (0.83)				230 (1.66)				291 (2.1)			569 (4.1)			874 (6.3)		
UPK566AW2				UPK569AW2				UPK596AW2			UPK599AW2			UPK5913AW2		
UPK566BW2				UPK569BW2				UPK596BW2			UPK599BW2			UPK5913BW2		
UPK566AJW				UPK569AJW				UPK596AJW			UPK599AJW			UPK5913AJW		
UPK566BJW				UPK569BJW				UPK596BJW			UPK599BJW			UPK5913BJW		
				UPK569AHW2				UPK596AHW2			UPK599AHW2			UPK5913AHW2		
				UPK569BHW2				UPK596BHW2			UPK599BHW2			UPK5913BHW2		
21.6 (2.5)		26 (3)		30.3 (3.5)		34.7 (4)		39 (4.5)			78.1 (9)			104 (12)		
UPK564AW-T7.2		UPK564AW-T10		UPK564AW-T20		UPK564AW-T30		UPK596AW-T3.6			UPK596AW-T7.2			UPK596AW-T20		
UPK564BW-T7.2		UPK564BW-T10		UPK564BW-T20		UPK564BW-T30		UPK596BW-T3.6			UPK596BW-T7.2			UPK596BW-T20		
											UPK596AW-T10			UPK596AW-T30		
											UPK596BW-T10			UPK596BW-T30		
UPK564AJW-T7.2		UPK564AJW-T10		UPK564AJW-T20		UPK564AJW-T30		UPK596AJW-T3.6			UPK596AJW-T7.2			UPK596AJW-T20		
UPK564BJW-T7.2		UPK564BJW-T10		UPK564BJW-T20		UPK564BJW-T30		UPK596BJW-T3.6			UPK596BJW-T7.2			UPK596BJW-T20		
											UPK596AJW-T10			UPK596AJW-T30		
											UPK596BJW-T10			UPK596BJW-T30		
30.3 (3.5)				52 (6)												
UPK566AW-N5				UPK564AW-N25												
UPK566BW-N5				UPK564BW-N25												
UPK566AW-N7.2				UPK564AW-N36												
UPK566BW-N7.2				UPK564BW-N36												
UPK566AW-N10				UPK564AW-N50												
UPK566BW-N10				UPK564BW-N50												
UPK566AJW-N5				UPK564AJW-N25												
UPK566BJW-N5				UPK564BJW-N25												
UPK566AJW-N7.2				UPK564AJW-N36												
UPK566BJW-N7.2				UPK564BJW-N36												
UPK566AJW-N10				UPK564AJW-N50												
UPK566BJW-N10				UPK564BJW-N50												

UPK·W Standard Type

UPK·W High-Speed Type

The **UPK·W** series of 5-phase stepping motor and driver packages are compact and provide high torque with low vibration.

They are optimal for controlling vibration and reducing noise.



■ FEATURES

● Standard Type

Available in three frame sizes of 1.65 inch (42mm) square, 2.36 inch (60mm) square and 3.35 inch (85mm) square.

● High-Speed Type

This product is suitable for applications requiring higher speed operation and smaller sized equipment.

■ SAFETY STANDARDS AND CE MARKING

Products	Applicable Standards	Authorizing Organization	File No.	CE Marking
Stepping Motor	UL1004, UL519 CAN/CSA-C22.2 No. 100 CAN/CSA-C22.2 No. 77	UL	E64199	Low Voltage Directive
	EN60950 EN60034-1 EN60034-5	VDE	6763üG	
Driver for Stepping Motor	UL508C CAN/CSA-C22.2 No. 14	UL	E17146	Low Voltage Directive
	EN60950, EN50178	DEMKO	See page D-15	

- See page D-9 for more information on operating conditions of EN/IEC standards.
- The EN/IEC standard certification depends on the type and installation size. For details, see Page D-15.
- Motors and drivers are recognized individually.

■ PRODUCT NUMBER CODE

UPK 5 6 9 A H W 2

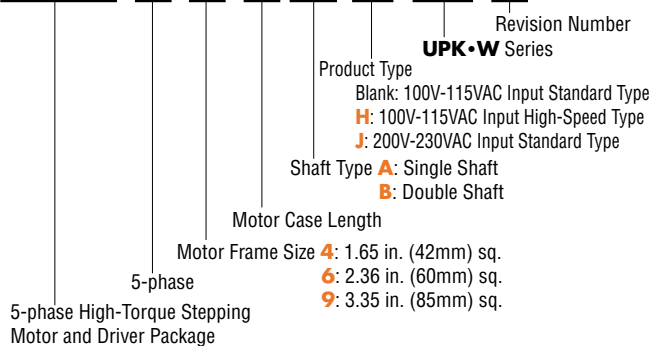

■ SPECIFICATIONS STANDARD TYPE Single-Phase 100-115VAC Input



Package Model	Single Shaft	UPK543AW	UPK544AW	UPK545AW
	Double Shaft	UPK543BW	UPK544BW	UPK545BW
Maximum Holding Torque	oz-in	18	24.9	33.3
	N·m	0.13	0.18	0.24
Rotor Inertia	oz-in ²	0.192	0.296	0.372
	kg·m ²	35×10 ⁻⁷	54×10 ⁻⁷	68×10 ⁻⁷
Rated Current	A/phase	0.75		
Basic Step Angle		0.72°		
Insulation Class		Class B [266°F (130°C)] Recognized as Class A [221°F (105°C)] by UL standard.		
Power Source		Single-Phase 100 115V 15% 60Hz 1.5A		
Output Current	A/phase	0.75		
Excitation Mode		<ul style="list-style-type: none"> ● Full Step (4 phase excitation): 0.72°/step ● Half Step (4-5 phase excitation): 0.36°/step (Switch selectable)		
Input Signals	Input Signal Circuit	Photocoupler input, Input resistance 220Ω, Input current 20mA maximum Signal voltage Photocoupler ON: +4~+5V, Photocoupler OFF: 0~+0.5V		
	● CW Pulse Signal (Pulse Signal)	CW direction step command pulse signal (Step command signal at 1-pulse input mode) Pulse width: 5μs minimum, Pulse rise/fall: 2μs maximum Motor moves when the photocoupler state changes from ON to OFF.		
	● CCW Pulse Signal (Rotation Direction Signal)	CCW direction step command signal (Rotation direction signal at 1-pulse input mode, Photocoupler ON: CW, Photocoupler OFF: CCW) Pulse width: 5μs minimum, Pulse rise/fall: 2μs maximum Motor moves when the photocoupler state changes from ON to OFF.		
	● All Windings Off Signal	When in the "photocoupler ON" state, the current to the motor is cut off and the motor shaft can be rotated manually. When in the "photocoupler OFF" state, the current level set by the RUN switch is supplied to the motor.		
Output Signals	Output Signal Circuit	Photocoupler, Open-Collector Output (Emitter common) External use condition: 24V DC maximum, 10mA maximum		
	● Excitation Timing Signal	The signal is output every time the excitation sequence returns to the initial stage "0". (Photocoupler : ON) Full step: signal output every 10 pulses, Half step: signal output every 20 pulses		
	● Overheat Signal	The signal is output when the internal temperature of the driver rises above approximately 176°F (80°C). (Photocoupler: ON) The motor stops automatically if the "Automatic Current Off" function is ON.		
Functions	Automatic current cutback, All windings off, Pulse input mode switch, Step angle switch			
Indicator (LED)	Power source input, Excitation timing signal output, Overheat signal output			
Driver Cooling Method	Natural Ventilation			
Waight (Mass)	Motor lb. (kg)	0.56 (0.25)	0.67 (0.3)	0.89 (0.4)
	Driver lb. (kg)	2.1 (0.95)		
Insulation Resistance	Motor	100M Ω minimum under normal temperature and humidity, when measured by a DC500V megger between the motor coils and the motor casing.		
	Driver	100M Ω minimum under normal temperature and humidity, when measured by a DC500V megger between the following places: <ul style="list-style-type: none"> ● Power input terminal — Protective earthing terminal ● Motor output terminal — Protective earthing terminal ● Signal input/output terminal — Power input terminal ● Signal input/output terminal — Motor output terminal 		
Dielectric Strength	Motor	Sufficient to withstand 1.0kV, 60Hz applied between the motor coils and casing for one minute, under normal temperature and humidity.		
	Driver	Sufficient to withstand the following for one minute, under normal temperature and humidity. <ul style="list-style-type: none"> ● Power input terminal — Protective earthing terminal AC1.5kV 60Hz ● Motor output terminal — Protective earthing terminal AC1.5kV 60Hz ● Signal input/output terminal — Power input terminal AC3.0kV 60Hz ● Signal input/output terminal — Motor output terminal AC3.0kV 60Hz 		
Ambient Temperature Range	Motor	+14°F~+122°F (-10°C~+50°C)		
	Driver	+32°F~+122°F (0°C~+50°C)		

● Maximum holding torque refers to the holding torque at motor standstill when the rated current is supplied to the motor (5-phase excitation). Use this value to compare motor torque performance. When using the motor with the dedicated driver, the driver's "Automatic Current Cutback" function at motor standstill reduces maximum holding torque by approximately 50%.

● The power source input current value represents the maximum current. (The input current varies according to the pulse frequency.)

Note : Do not measure insulation resistance or perform the dielectric strength test while the motor and driver are connected.

STANDARD TYPE Single-Phase 100-115VAC Input



Package Model	Single Shaft	UPK564AW2	UPK566AW2	UPK569AW2	UPK596AW2	UPK599AW2	UPK5913AW2
	Double Shaft	UPK564BW2	UPK566BW2	UPK569BW2	UPK596BW2	UPK599BW2	UPK5913BW2
Maximum Holding Torque	oz-in	58.3	115	230	291	569	874
	N·m	0.42	0.83	1.66	2.1	4.1	6.3
Rotor Inertia	oz-in ²	0.96	1.53	3.07	7.66	14.8	21.9
	kg·m ²	175×10 ⁻⁷	280×10 ⁻⁷	560×10 ⁻⁷	1400×10 ⁻⁷	2700×10 ⁻⁷	4000×10 ⁻⁷
Rated Current	A/phase	1.4					
Basic Step Angle		0.72°					
Insulation Class		Class B [266°F (130°C)] Recognized as Class A [221°F (105°C)] by UL and CSA standards.					
Power Source		Single-Phase 100 115V 15% 60Hz 5.5A					
Output Current	A/phase	1.4					
Excitation Mode		<ul style="list-style-type: none"> ● Full Step (4 phase excitation): 0.72°/step ● Half Step (4-5 phase excitation): 0.36°/step (Switch selectable) 					
Input Signals	Input Signal Circuit	Photocoupler input, Input resistance 220Ω, Input current 20mA maximum Signal voltage Photocoupler ON: +4~+5V, Photocoupler OFF: 0~+0.5V					
	● CW Pulse Signal (Pulse Signal)	CW direction step command pulse signal (Step command signal at 1-pulse input mode) Pulse width: 5μs minimum, Pulse rise/fall: 2μs maximum Motor moves when the photocoupler state changes from ON to OFF.					
	● CCW Pulse Signal (Rotation Direction Signal)	CCW direction step command signal (Rotation direction signal at 1-pulse input mode, Photocoupler ON: CW, Photocoupler OFF: CCW) Pulse width: 5μs minimum, Pulse rise/fall: 2μs maximum Motor moves when the photocoupler state changes from ON to OFF.					
	● All windings Off Signal	When in the "photocoupler ON" state, the current to the motor is cut off and the motor shaft can be rotated manually. When in the "photocoupler OFF" state, the current level set by the RUN switch is supplied to the motor.					
Output Signals	Output Signal Circuit	Photocoupler, Open-Collector Output (Emitter common) External use condition: 24V DC maximum, 10mA maximum					
	● Excitation Timing Signal	The signal is output every time the excitation sequence returns to the initial stage "0". (Photocoupler : ON) Full step: signal output every 10 pulses, Half step: signal output every 20 pulses					
	● Overheat Signal	The signal is output when the internal temperature of the driver rises above approximately 176°F (80°C). (Photocoupler: ON) The motor stops automatically if the "Automatic Current Off" function is ON.					
Functions		Automatic current cutback, All windings off, Pulse input mode switch, Step angle switch					
Indicator (LED)		Power source input, Excitation timing signal output, Overheat signal output					
Driver Cooling Method		Natural Ventilation					
Weight (Mass)	Motor lb. (kg)	1.33 (0.6)	1.77 (0.8)	2.87 (1.3)	3.75 (1.7)	6.18 (2.8)	8.38 (3.8)
	Driver lb. (kg)	2.1 (0.95)					
Insulation Resistance	Motor	100M Ω minimum under normal temperature and humidity, when measured by a DC500V megger between the motor coils and the motor casing.					
	Driver	100M Ω minimum under normal temperature and humidity, when measured by a DC500V megger between the following places: <ul style="list-style-type: none"> ● Power input terminal — Protective earthing terminal ● Motor output terminal — Protective earthing terminal ● Signal input/output terminal — Power input terminal ● Signal input/output terminal — Motor output terminal 					
Dielectric Strength	Motor	Sufficient to withstand 1.5kV, 60Hz applied between the motor coils and casing for one minute, under normal temperature and humidity.					
	Driver	Sufficient to withstand the following for one minute, under normal temperature and humidity. <ul style="list-style-type: none"> ● Power input terminal — Protective earthing terminal AC1.5kV 60Hz ● Motor output terminal — Protective earthing terminal AC1.5kV 60Hz ● Signal input/output terminal — Power input terminal AC3.0kV 60Hz ● Signal input/output terminal — Motor output terminal AC3.0kV 60Hz 					
Ambient Temperature Range	Motor	+14°F~+122°F (-10°C~+50°C)					
	Driver	+32°F~+122°F (0°C~+50°C)					

- Maximum holding torque refers to the holding torque at motor standstill when the rated current is supplied to the motor (5-phase excitation). Use this value to compare motor torque performance. When using the motor with the dedicated driver, the driver's "Automatic Current Cutback" function at motor standstill reduces maximum holding torque by approximately 50%.
- The power source input current value represents the maximum current. (The input current varies according to the pulse frequency.)

STANDARD TYPE Single-Phase 200-230VAC Input



Package Model	Single Shaft	UPK564AJW	UPK566AJW	UPK569AJW	UPK596AJW	UPK599AJW	UPK5913AJW
	Double Shaft	UPK564BJW	UPK566BJW	UPK569BJW	UPK596BJW	UPK599BJW	UPK5913BJW
Maximum Holding Torque	oz-in	58.3	115	230	291	569	874
	N·m	0.42	0.83	1.66	2.1	4.1	6.3
Rotor Inertia	oz-in ²	0.96	1.53	3.07	7.66	14.8	21.9
	kg·m ²	175×10 ⁻⁷	280×10 ⁻⁷	560×10 ⁻⁷	1400×10 ⁻⁷	2700×10 ⁻⁷	4000×10 ⁻⁷
Rated Current	A/phase	1.4					
Basic Step Angle		0.72°					
Insulation Class		Class B [266°F (130°C)] Recognized as Class A [221°F (105°C)] by UL and CSA standards.					
Power Source		Single-Phase 200-230V ^{+10%} / _{-15%} 60Hz 3.5A					
Output Current	A/phase	1.4					
Excitation Mode		<ul style="list-style-type: none"> ● Full Step (4 phase excitation): 0.72°/step ● Half Step (4-5 phase excitation): 0.36°/step (Switch selectable) 					
Input Signals	Input Signal Circuit	Photocoupler input, Input resistance 220Ω, Input current 20mA maximum Signal voltage Photocoupler ON: +4~+5V, Photocoupler OFF: 0~+0.5V					
	● CW Pulse Signal (Pulse Signal)	CW direction step command pulse signal (Step command signal at 1-pulse input mode) Pulse width: 5μs minimum, Pulse rise/fall: 2μs maximum Motor moves when the photocoupler state changes from ON to OFF.					
	● CCW Pulse Signal (Rotation Direction Signal)	CCW direction step command signal (Rotation direction signal at 1-pulse input mode, Photocoupler ON: CW, Photocoupler OFF: CCW) Pulse width: 5μs minimum, Pulse rise/fall: 2μs maximum Motor moves when the photocoupler state changes from ON to OFF.					
	● All windings Off Signal	When in the "photocoupler ON" state, the current to the motor is cut off and the motor shaft can be rotated manually. When in the "photocoupler OFF" state, the current level set by the RUN switch is supplied to the motor.					
Output Signals	Output Signal Circuit	Photocoupler, Open-Collector Output (Emitter common) External use condition: 24V DC maximum, 10mA maximum					
	● Excitation Timing Signal	The signal is output every time the excitation sequence returns to the initial stage "0". (Photocoupler : ON) Full step: signal output every 10 pulses, Half step: signal output every 20 pulses					
	● Overheat Signal	The signal is output when the internal temperature of the driver rises above approximately 176°F (80°C). (Photocoupler: ON) The motor stops automatically if the "Automatic Current Off" function is ON.					
Functions		Automatic current cutback, All windings off, Pulse input mode switch, Step angle switch					
Indicator (LED)		Power source input, Excitation timing signal output, Overheat signal output					
Driver Cooling Method		Natural Ventilation					
Weight (Mass)	Motor lb. (kg)	1.33 (0.6)	1.77 (0.8)	2.87 (1.3)	3.75 (1.7)	6.18 (2.8)	8.38 (3.8)
	Driver lb. (kg)	2.1 (0.95)					
Insulation Resistance	Motor	100M Ω minimum under normal temperature and humidity, when measured by a DC500V megger between the motor coils and the motor casing.					
	Driver	100M Ω minimum under normal temperature and humidity, when measured by a DC500V megger between the following places: <ul style="list-style-type: none"> ● Power input terminal — Protective earthing terminal ● Motor output terminal — Protective earthing terminal ● Signal input/output terminal — Power input terminal ● Signal input/output terminal — Motor output terminal 					
Dielectric Strength	Motor	Sufficient to withstand 1.5kV, 60Hz applied between the motor coils and casing for one minute, under normal temperature and humidity.					
	Driver	Sufficient to withstand the following for one minute, under normal temperature and humidity. <ul style="list-style-type: none"> ● Power input terminal — Protective earthing terminal AC1.8kV 60Hz ● Motor output terminal — Protective earthing terminal AC1.8kV 60Hz ● Signal input/output terminal — Power input terminal AC3.2kV 60Hz ● Signal input/output terminal — Motor output terminal AC3.2kV 60Hz 					
Ambient Temperature Range	Motor	+14°F~+122°F (-10°C~+50°C)					
	Driver	+32°F~+122°F (0°C~+50°C)					

- Maximum holding torque refers to the holding torque at motor standstill when the rated current is supplied to the motor (5-phase excitation). Use this value to compare motor torque performance. When using the motor with the dedicated driver, the driver's "Automatic Current Cutback" function at motor standstill reduces maximum holding torque by approximately 50%.
- The power source input current value represents the maximum current. (The input current varies according to the pulse frequency.)

HIGH-SPEED TYPE Single-Phase 100-115VAC Input



Package Model	Single Shaft	UPK569AHW2	UPK596AHW2	UPK599AHW2	UPK5913AHW2
	Double Shaft	UPK569BHW2	UPK596BHW2	UPK599BHW2	UPK5913BHW2
Maximum Holding Torque	oz-in	230	291	569	874
	N·m	1.66	2.1	4.1	6.3
Rotor Inertia	oz-in ²	3.06	7.66	14.8	21.9
	kg·m ²	560×10 ⁻⁷	1400×10 ⁻⁷	2700×10 ⁻⁷	4000×10 ⁻⁷
Rated Current	A/phase	2.8			
Basic Step Angle		0.72°			
Insulation Class		Class B [266°F (130°C)] Recognized as Class A [221°F (105°C)] by UL and CSA standards.			
Power Source		Single-Phase 100-115V±15% 50/60Hz 8A			
Output Current	A/phase	2.8			
Excitation Mode		<ul style="list-style-type: none"> ● Full Step (4 phase excitation): 0.72°/step ● Half Step (4-5 phase excitation): 0.36°/step (Switch selectable) 			
Input Signals	Input Signal Circuit	Photocoupler input, Input resistance 220Ω, Input current 20mA maximum Signal voltage Photocoupler ON: +4~+5V, Photocoupler OFF: 0~+0.5V			
	● CW Pulse Signal (Pulse Signal)	CW direction step command pulse signal (Step command signal at 1-pulse input mode) Pulse width: 5μs minimum, Pulse rise/fall: 2μs maximum Motor moves when the photocoupler state changes from ON to OFF.			
	● CCW Pulse Signal (Rotation Direction Signal)	CCW direction step command signal (Rotation direction signal at 1-pulse input mode, Photocoupler ON: CW, Photocoupler OFF: CCW) Pulse width: 5μs minimum, Pulse rise/fall: 2μs maximum Motor moves when the photocoupler state changes from ON to OFF.			
	● All Windings Off Signal	When in the "photocoupler ON" state, the current to the motor is cut off and the motor shaft can be rotated manually. When in the "photocoupler OFF" state, the current level set by the RUN switch is supplied to the motor.			
Output Signals	Output Signal Circuit	Photocoupler, Open-Collector Output (Emitter common) External use condition: 24V DC maximum, 10mA maximum			
	● Excitation Timing Signal	The signal is output every time the excitation sequence returns to the initial stage "0". (Photocoupler : ON) Full step: signal output every 10 pulses, Half step: signal output every 20 pulses			
	● Overheat Signal	The signal is output when the internal temperature of the driver rises above approximately 176°F (80°C). (Photocoupler: ON) The motor stops automatically if the "Automatic Current Off" function is ON.			
Functions		Automatic current cutback, All windings off, Pulse input mode switch, Step angle switch			
Indicator (LED)		Power source input, Excitation timing signal output, Overheat signal output			
Driver Cooling Method		Internal Fan			
Waight (Mass)	Motor lb.(kg)	2.87 (1.3)	3.75 (1.7)	6.18 (2.8)	8.38 (3.8)
	Driver lb.(kg)	2.43 (1.1)			
Insulation Resistance	Motor	100M Ω minimum under normal temperature and humidity, when measured by a DC500V megger between the motor coils and the motor casing.			
	Driver	100M Ω minimum under normal temperature and humidity, when measured by a DC500V megger between the following places: <ul style="list-style-type: none"> ● Power input terminal — Protective earthing terminal ● Motor output terminal — Protective earthing terminal ● Signal input/output terminal — Power input terminal ● Signal input/output terminal — Motor output terminal 			
Dielectric Strength	Motor	Sufficient to withstand 1.5kV, 60Hz applied between the motor coils and casing for one minute, under normal temperature and humidity.			
	Driver	Sufficient to withstand the following for one minute, under normal temperature and humidity. <ul style="list-style-type: none"> ● Power input terminal — Protective earthing terminal AC1.5kV 60Hz ● Motor output terminal — Protective earthing terminal AC1.5kV 60Hz ● Signal input/output terminal — Power input terminal AC3.0kV 60Hz ● Signal input/output terminal — Motor output terminal AC3.0kV 60Hz 			
Ambient Temperature Range	Motor	+14°F~+122°F (-10°C~+50°C)			
	Driver	+32°F~+122°F (0°C~+50°C)			

- Maximum holding torque refers to the holding torque at motor standstill when the rated current is supplied to the motor (5-phase excitation). Use this value to compare motor torque performance. When using the motor with the dedicated driver, the driver's "Automatic Current Cutback" function at motor standstill reduces maximum holding torque by approximately 50%.
- The power source input current value represents the maximum current. (The input current varies according to the pulse frequency.)

■ SPEED vs. TORQUE CHARACTERISTICS

fs: Maximum Starting Pulse Rate

● Standard Type

UPK543BW

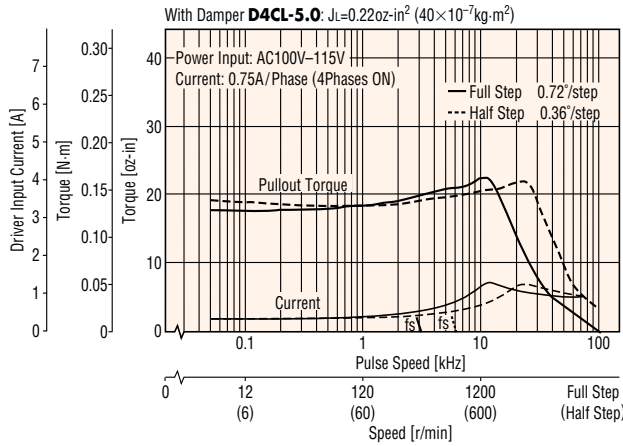

UPK564BW2

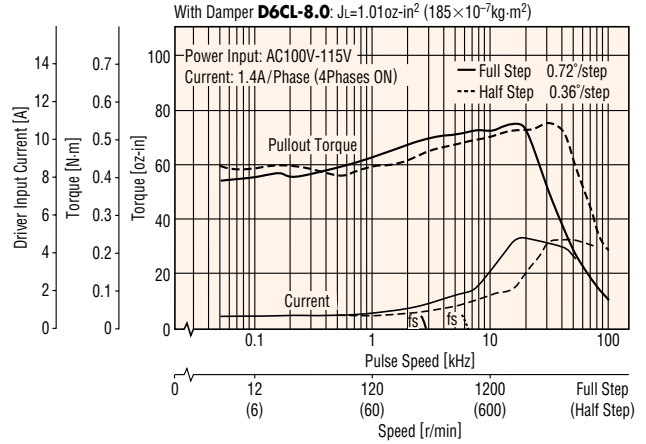

UPK544BW

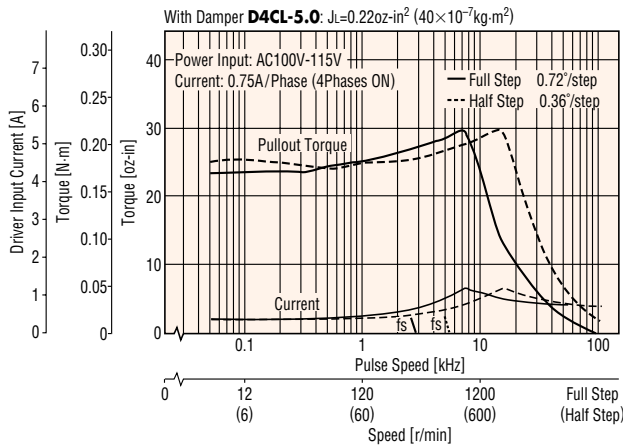

UPK566BW2

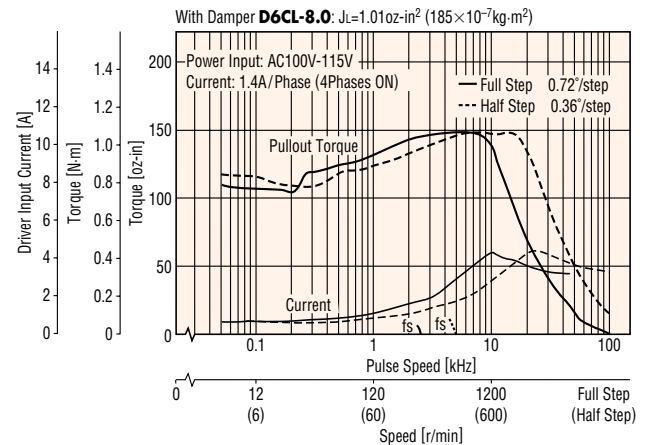

UPK545BW

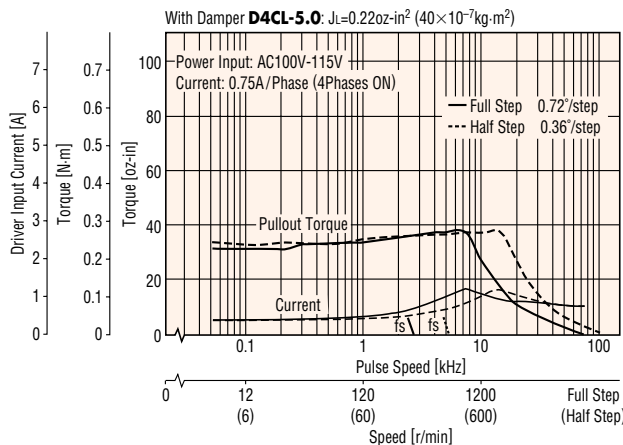

UPK569BW2

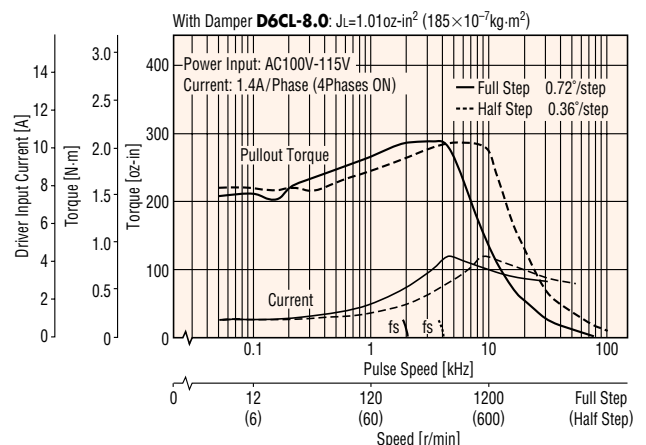

Note:

- Pay attention to heat dissipation from the motor and driver. The motor will produce a considerable amount of heat under certain conditions. Be sure to keep the temperature of the motor case under 212°F (100°C). [Under 167°F (75°C) is required to comply with UL or CSA standards. **UPK54□W** is under application.]
- When using the motor with the dedicated driver, the driver's "Automatic Current Cutback" function at motor standstill reduces maximum holding torque by approximately 50%.

■ SPEED vs. TORQUE CHARACTERISTICS

● Standard Type

UPK596BW2

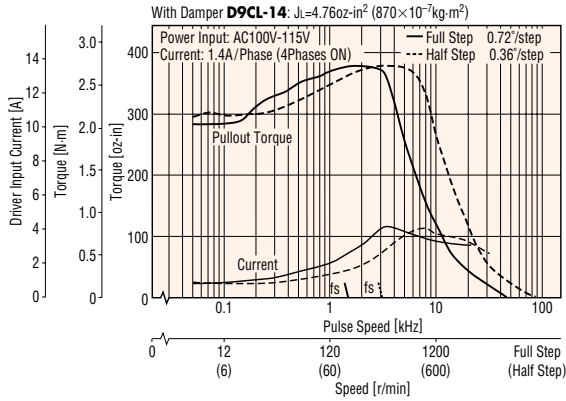

UPK599BW2

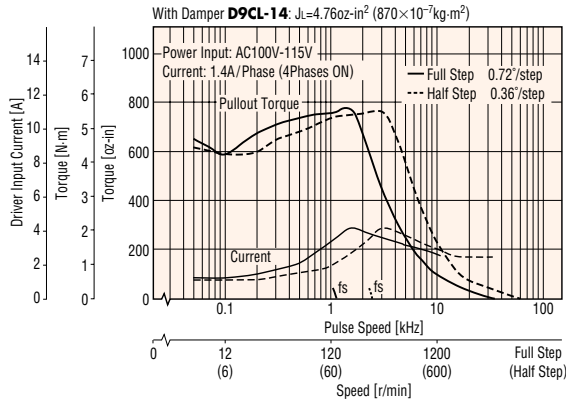

UPK5913BW2

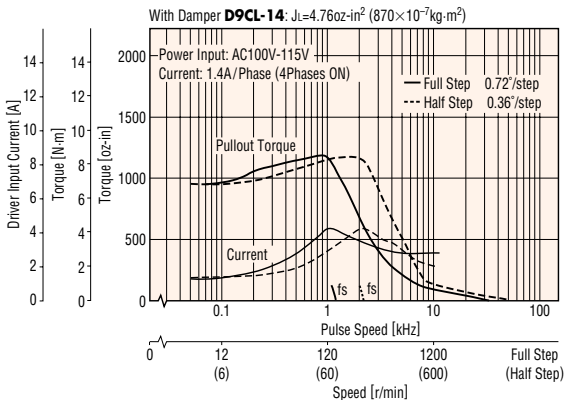

Note:

- Pay attention to heat dissipation from the motor and driver. The motor will produce a considerable amount of heat under certain conditions. Be sure to keep the temperature of the motor case under 212°F (100°C). [Under 167°F (75°C) is required to comply with UL or CSA standards.]
- When using the motor with the dedicated driver, the driver's "Automatic Current Cutback" function at motor standstill reduces maximum holding torque by approximately 50%.

fs: Maximum Starting Pulse Rate

UPK564BJW

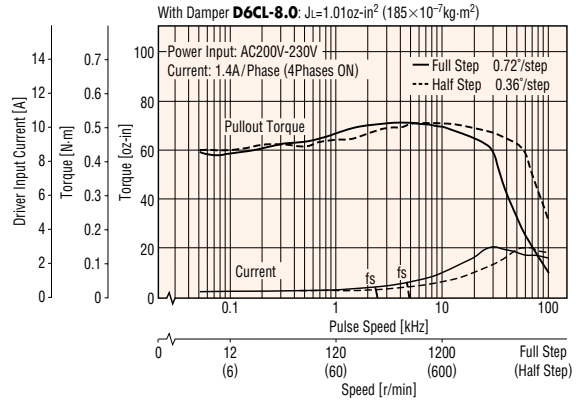

UPK566BJW

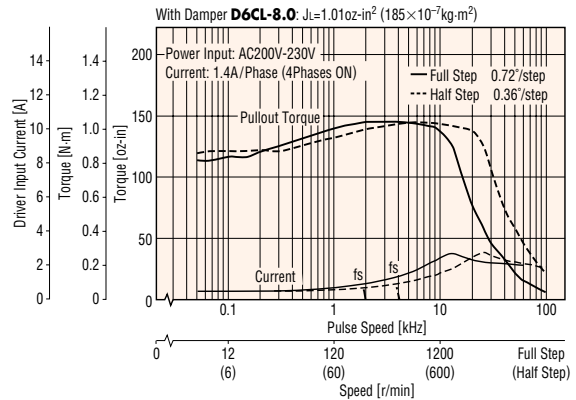

UPK569BJW

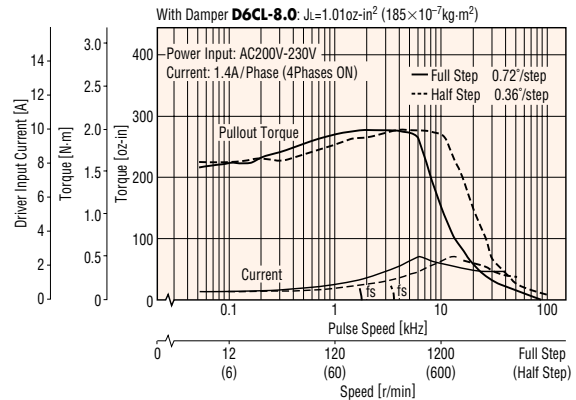

UPK596BJW

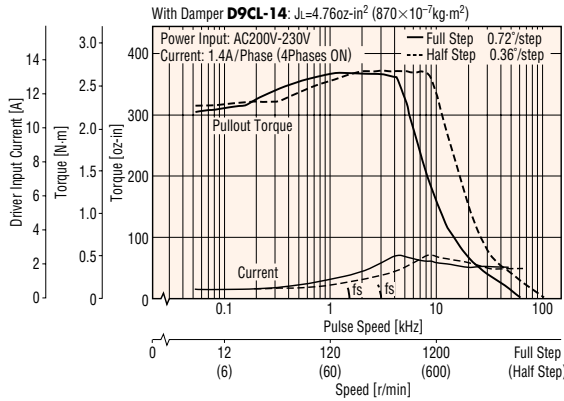

UPK599BJW

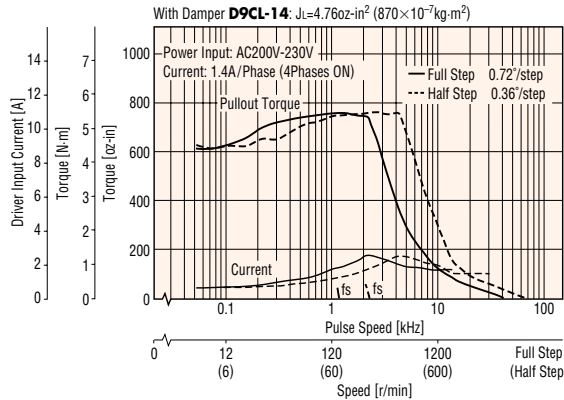

UPK5913BJW

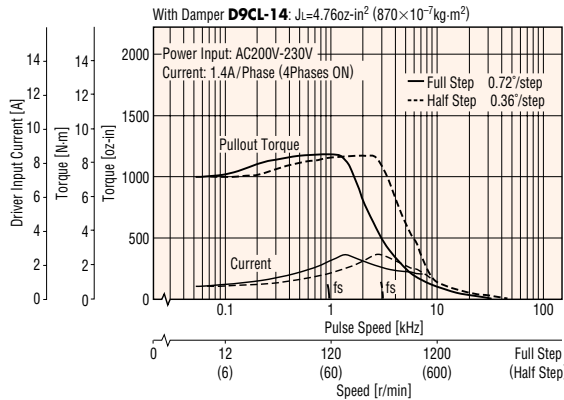

High-Speed Type

UPK569BHW2

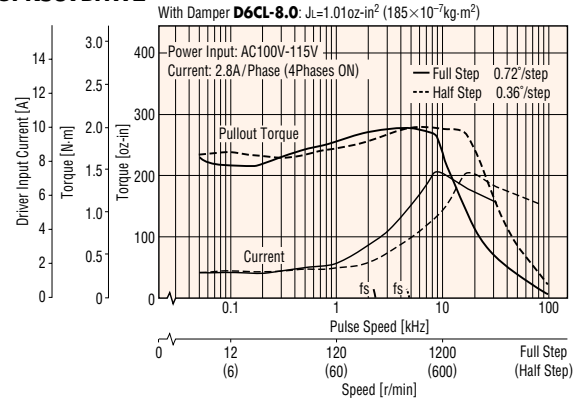

UPK596BHW2

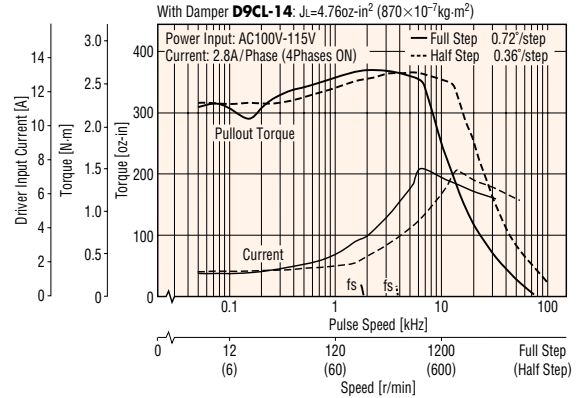

UPK599BHW2

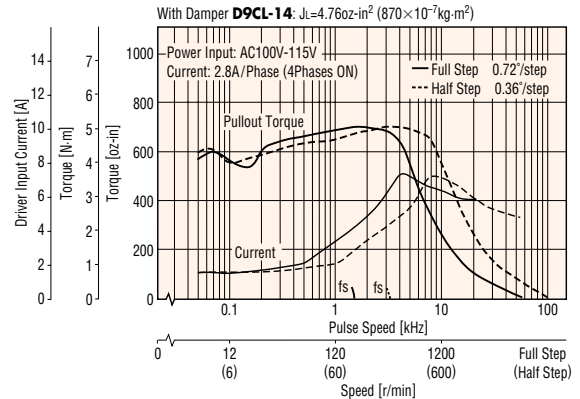

UPK5913BHW2

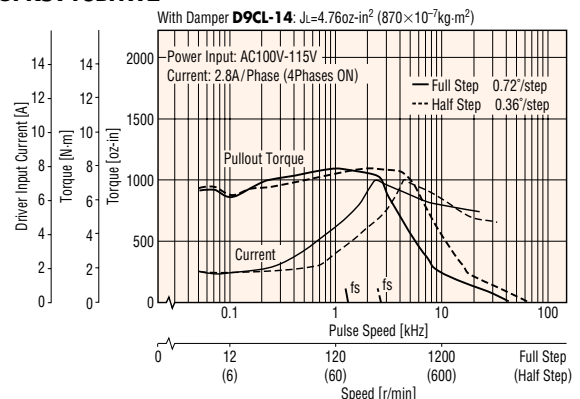

Note:

- Pay attention to heat dissipation from the motor and driver. The motor will produce a considerable amount of heat under certain conditions. Be sure to keep the temperature of the motor case under 212°F (100°C). [Under 167°F (75°C) is required to comply with UL or CSA standards.]
- When using the motor with the dedicated driver, the driver's "Automatic Current Cutback" function at motor standstill reduces maximum holding torque by approximately 50%.

■ DIMENSIONS scale 1/4, unit = inch (mm)

● MOTOR (Standard and High-Speed Type)

UPK543AW (Single shaft)

Motor Model: PK543AW Weight 0.56 lb. (Mass 0.25kg)

UPK543BW (Double shaft)

Motor Model: PK543BW Weight 0.56 lb. (Mass 0.25kg)

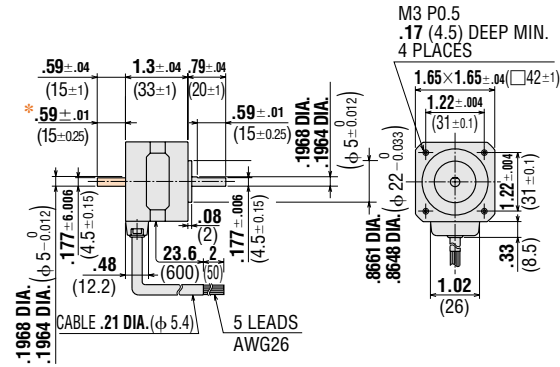

*.59±.01 (15±0.25) indicates the length of milling on motor shaft.

UPK544AW (Single shaft)

Motor Model: PK544AW Weight 0.67 lb. (Mass 0.3kg)

UPK544BW (Double shaft)

Motor Model: PK544BW Weight 0.67 lb. (Mass 0.3kg)

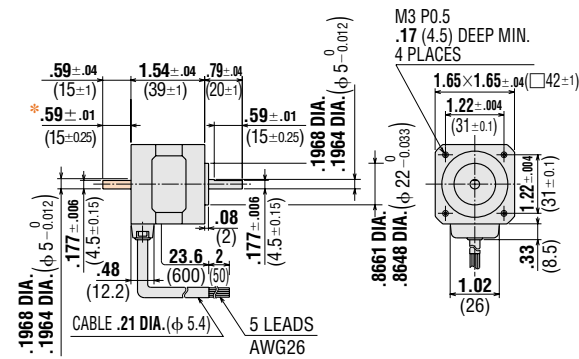

*.59±.01 (15±0.25) indicates the length of milling on motor shaft.

UPK545AW (Single shaft)

Motor Model: PK545AW Weight 0.89 lb. (Mass 0.4kg)

UPK545BW (Double shaft)

Motor Model: PK545BW Weight 0.89 lb. (Mass 0.4kg)

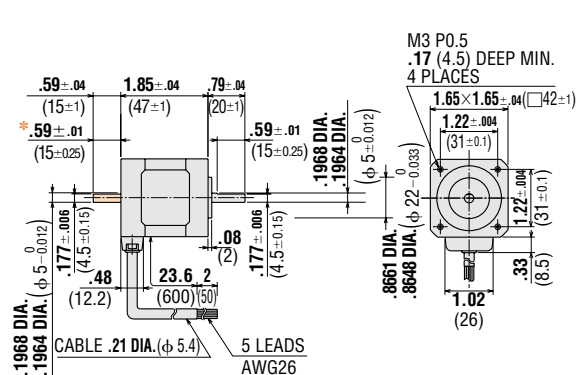

*.59±.01 (15±0.25) indicates the length of milling on motor shaft.

● These external appearance drawings are for double shaft models. For a single shaft, ignore the colored areas.

See page B-36 for information on motor installation.

UPK564AW2, UPK564AJW (Single shaft)

Motor Model: PK564AW Weight 1.33 lb. (Mass 0.6kg)

UPK564BW2, UPK564BJW (Double shaft)

Motor Model: PK564BW Weight 1.33 lb. (Mass 0.6kg)

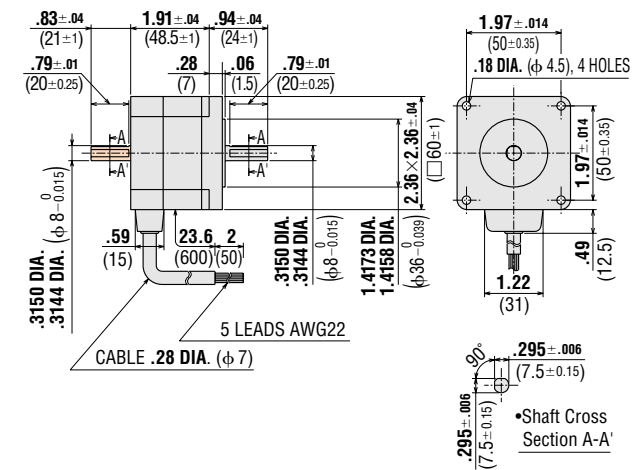

UPK566AW2, UPK566AJW (Single shaft)

Motor Model: PK566AW Weight 1.77 lb. (Mass 0.8kg)

UPK566BW2, UPK566BJW (Double shaft)

Motor Model: PK566BW Weight 1.77 lb. (Mass 0.8kg)

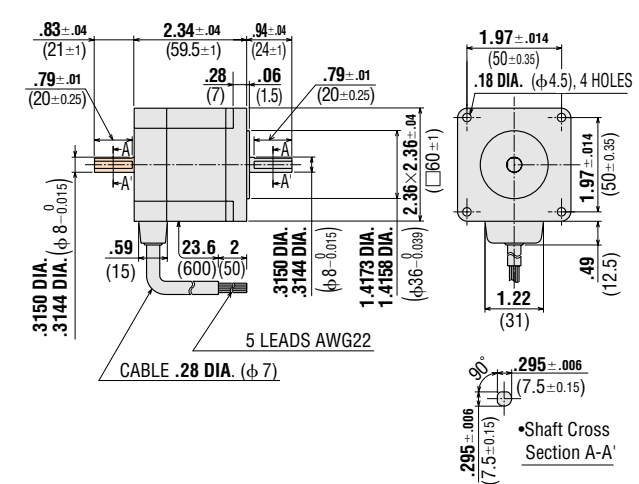

UPK569AW2, UPK569AJW (Single shaft)

Motor Model: PK569AW Weight 2.87 lb. (Mass 1.3kg)

UPK569AHW2 (Single shaft)

Motor Model: PK569AHW Weight 2.87 lb. (Mass 1.3kg)

UPK569BW2, UPK569BJW (Double shaft)

Motor Model: PK569BW Weight 2.87 lb. (Mass 1.3kg)

UPK569BHW2 (Double shaft)

Motor Model: PK569BHW Weight 2.87 lb. (Mass 1.3kg)

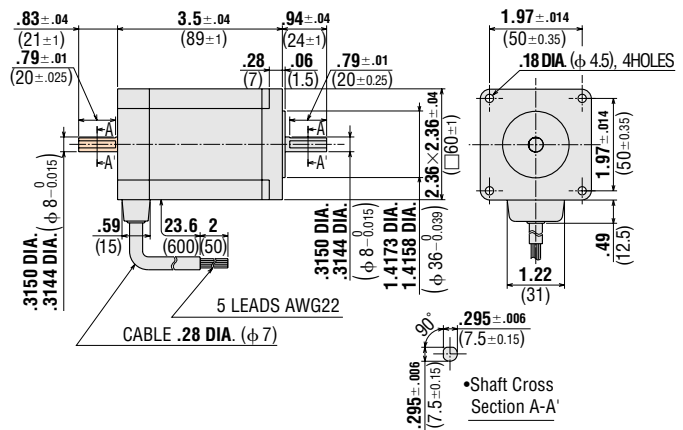

UPK596AW2, UPK596AJW (Single shaft)
 Motor Model: PK596AW Weight 3.75 lb. (Mass 1.7kg)
UPK596AHW2 (Single shaft)
 Motor Model: PK596AHW Weight 3.75 lb. (Mass 1.7kg)

UPK596BW2, UPK596BJW (Double shaft)
 Motor Model: PK596BW Weight 3.75 lb. (Mass 1.7kg)
UPK596BHW2 (Double shaft)
 Motor Model: PK596BHW Weight 3.75 lb. (Mass 1.7kg)

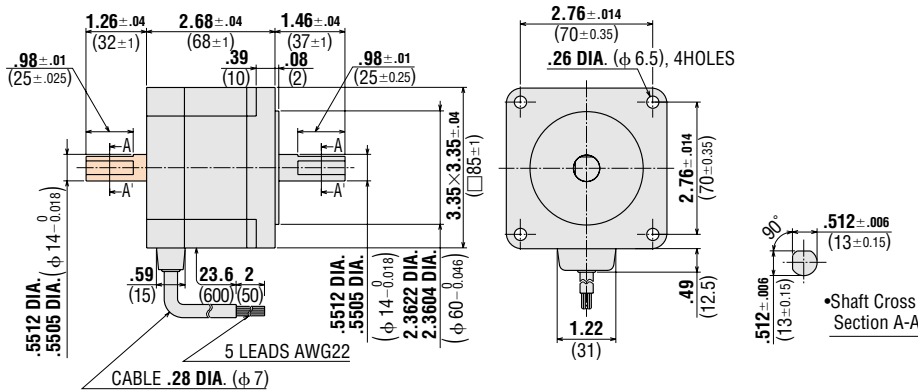

UPK599AW2, UPK599AJW (Single shaft)
 Motor Model: PK599AW Weight 6.18 lb. (Mass 2.8kg)
UPK599AHW2 (Single shaft)
 Motor Model: PK599AHW Weight 6.18 lb. (Mass 2.8kg)

UPK599BW2, UPK599BJW (Double shaft)
 Motor Model: PK599BW Weight 6.18 lb. (Mass 2.8kg)
UPK599BHW2 (Double shaft)
 Motor Model: PK599BHW Weight 6.18 lb. (Mass 2.8kg)

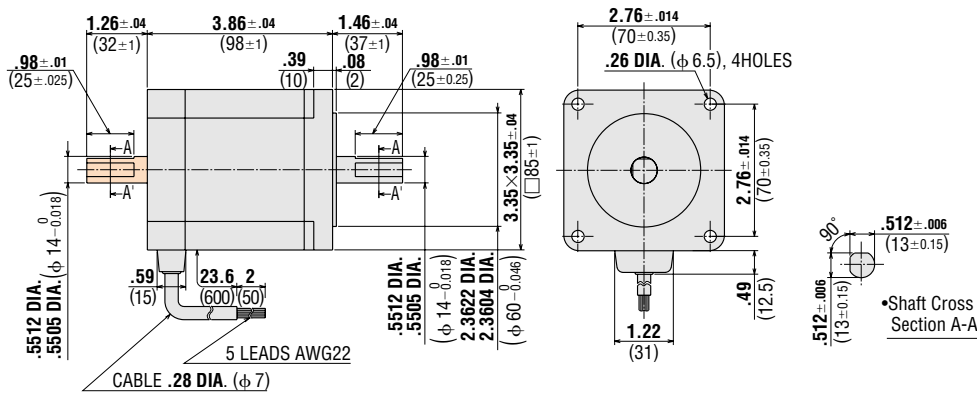

UPK5913AW2, UPK5913AJW (Single shaft)
 Motor Model: PK5913AW Weight 8.38 lb. (Mass 3.8kg)
UPK5913AHW2 (Single shaft)
 Motor Model: PK5913AHW Weight 8.38 lb. (Mass 3.8kg)

UPK5913BW2, UPK5913BJW (Double shaft)
 Motor Model: PK5913BW Weight 8.38 lb. (Mass 3.8kg)
UPK5913BHW2 (Double shaft)
 Motor Model: PK5913BHW Weight 8.38 lb. (Mass 3.8kg)

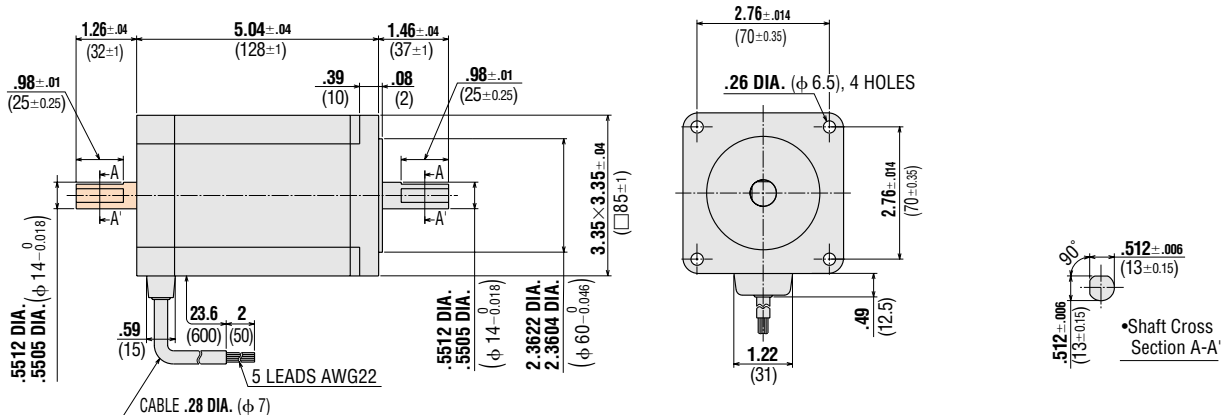

● These external appearance drawings are for double shaft models. For a single shaft, ignore the colored areas.

See page B-36 for information on motor installation.

■ DIMENSIONS scale 1/4, unit = inch (mm)

● Driver

Single-Phase 100-115VAC Input Standard Type

For **UPK543□W, UPK544□W, UPK545□W**

Driver Model: UDK5107NW2 Weight 2.1 lb. (Mass 0.95kg)

For **UPK564□W2, UPK566□W2, UPK569□W2, UPK596□W2, UPK599□W2, UPK5913□W2**

Driver Model: UDK5114NW2 Weight 2.1 lb. (Mass 0.95kg)

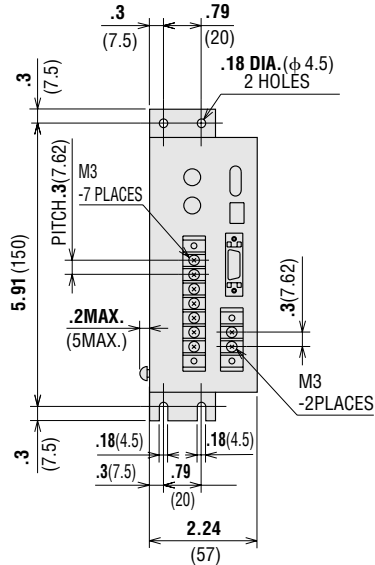
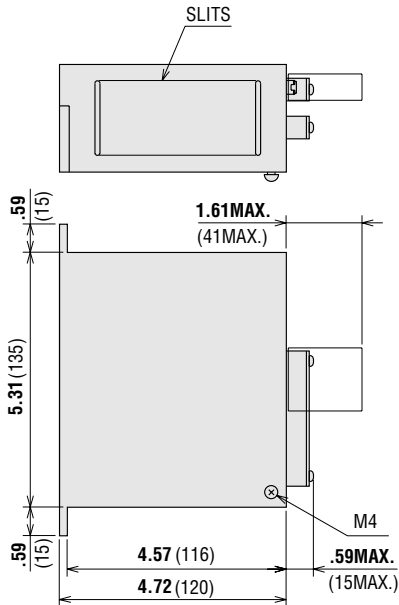

- I/O Connector (Included)
Connector: 54306-2011 (MOLEX)
Connector: 54331-1201 (MOLEX)

Single-Phase 200-230VAC Input Standard Type

For **UPK564□JW, UPK566□JW, UPK569□JW, UPK596□JW, UPK599□JW, UPK5913□JW**

Driver Model: UDK5214NW Weight 2.1 lb. (Mass 0.95kg)

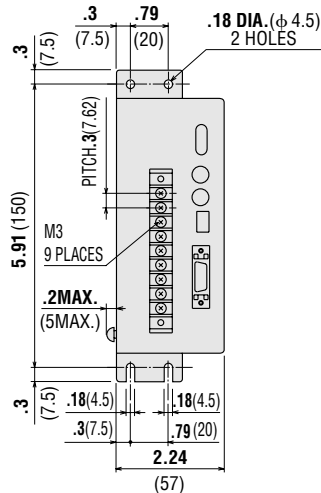
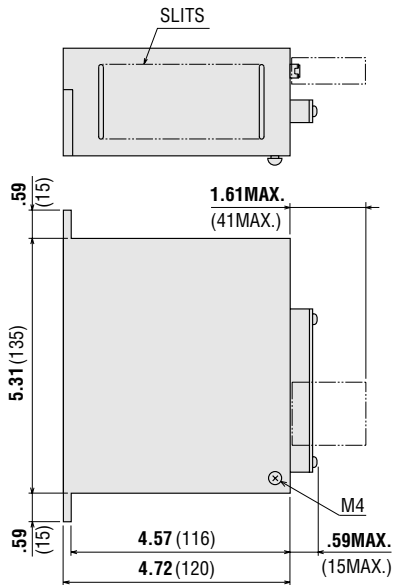

- I/O Connector (Included)
Connector: 54306-2011 (MOLEX)
Connector: 54331-1201 (MOLEX)

See page B-38 for information on driver installation.

Single-Phase 100-115VAC Input High-Speed Type

For **UPK569□HW2, UPK596□HW2,**
UPK599□HW2, UPK5913□HW2

Driver Model: UDK5128NW2 Weight 2.43 lb. (Mass 1.1kg)

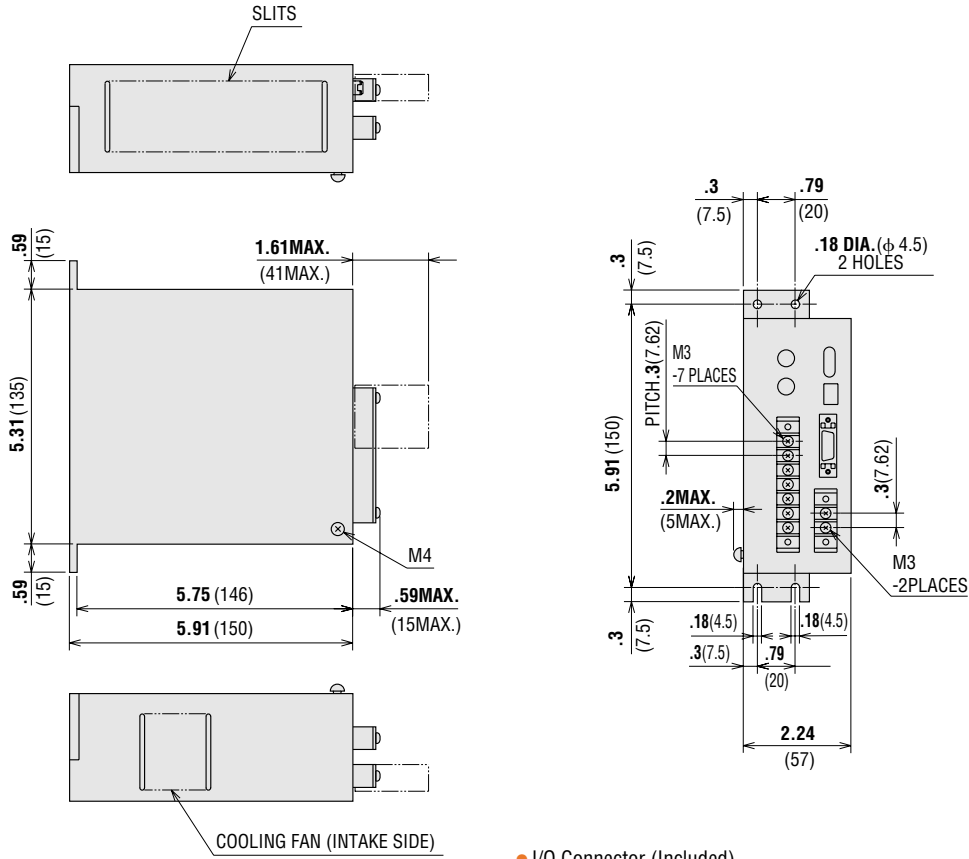

- I/O Connector (Included)
 Connector: 54306-2011 (MOLEX)
 Connector: 54331-1201 (MOLEX)

See page B-38 for information on driver installation.

■ LIST OF MOTOR AND DRIVER COMBINATIONS

Type	Package Model	Stepping Motor		Driver
		Model	Current A/phase	Model
Standard	UPK543□W UPK544□W UPK545□W	PK543□W PK544□W PK545□W	0.75	UDK5107NW2
	UPK564□W2 UPK566□W2 UPK569□W2 UPK596□W2 UPK599□W2 UPK5913□W2	PK564□W PK566□W PK569□W PK596□W PK599□W PK5913□W	1.4	UDK5114NW2
	UPK564□JW UPK566□JW UPK569□JW UPK596□JW UPK599□JW UPK5913□JW	PK564□W PK566□W PK569□W PK596□W PK599□W PK5913□W	1.4	UDK5214NW
High-Speed	UPK569□HW2 UPK596□HW2 UPK599□HW2 UPK5913□HW2	PK569□HW PK596□HW PK599□HW PK5913□HW	2.8	UDK5128NW2
TH Geared	UPK543□W-T3.6 UPK543□W-T7.2 UPK543□W-T10 UPK543□W-T20 UPK543□W-T30	PK543□W-T3.6 PK543□W-T7.2 PK543□W-T10 PK543□W-T20 PK543□W-T30	0.75	UDK5107NW2
	UPK564□W-T3.6 UPK564□W-T7.2 UPK564□W-T10 UPK564□W-T20 UPK564□W-T30 UPK596□W-T3.6 UPK596□W-T7.2 UPK596□W-T10 UPK596□W-T20 UPK596□W-T30	PK564□W-T3.6 PK564□W-T7.2 PK564□W-T10 PK564□W-T20 PK564□W-T30 PK596□W-T3.6 PK596□W-T7.2 PK596□W1-T10 PK596□W1-T20 PK596□W1-T30	1.4	UDK5114NW2
	UPK564□JW-T3.6 UPK564□JW-T7.2 UPK564□JW-T10 UPK564□JW-T20 UPK564□JW-T30 UPK596□JW-T3.6 UPK596□JW-T7.2 UPK596□JW-T10 UPK596□JW-T20 UPK596□JW-T30	PK564□W-T3.6 PK564□W-T7.2 PK564□W-T10 PK564□W-T20 PK564□W-T30 PK596□W-T3.6 PK596□W-T7.2 PK596□W-T10 PK596□W-T20 PK596□W-T30	1.4	UDK5214NW
PN Geared	UPK566□W-N5 UPK566□W-N7.2 UPK566□W-N10 UPK564□W-N25 UPK564□W-N36 UPK564□W-N50	PK566□W-N5 PK566□W-N7.2 PK566□W-N10 PK564□W-N25 PK564□W-N36 PK564□W-N50	1.4	UDK5114NW2
	UPK566□JW-N5 UPK566□JW-N7.2 UPK566□JW-N10 UPK564□JW-N25 UPK564□JW-N36 UPK564□JW-N50	PK566□W-N5 PK566□W-N7.2 PK566□W-N10 PK564□W-N25 PK564□W-N36 PK564□W-N50	1.4	UDK5214NW

Enter **A** (single shaft) or **B** (double shaft) in the □ within the model numbers.

■ WIRING DIAGRAMS

● Single-Phase 100-115VAC Input

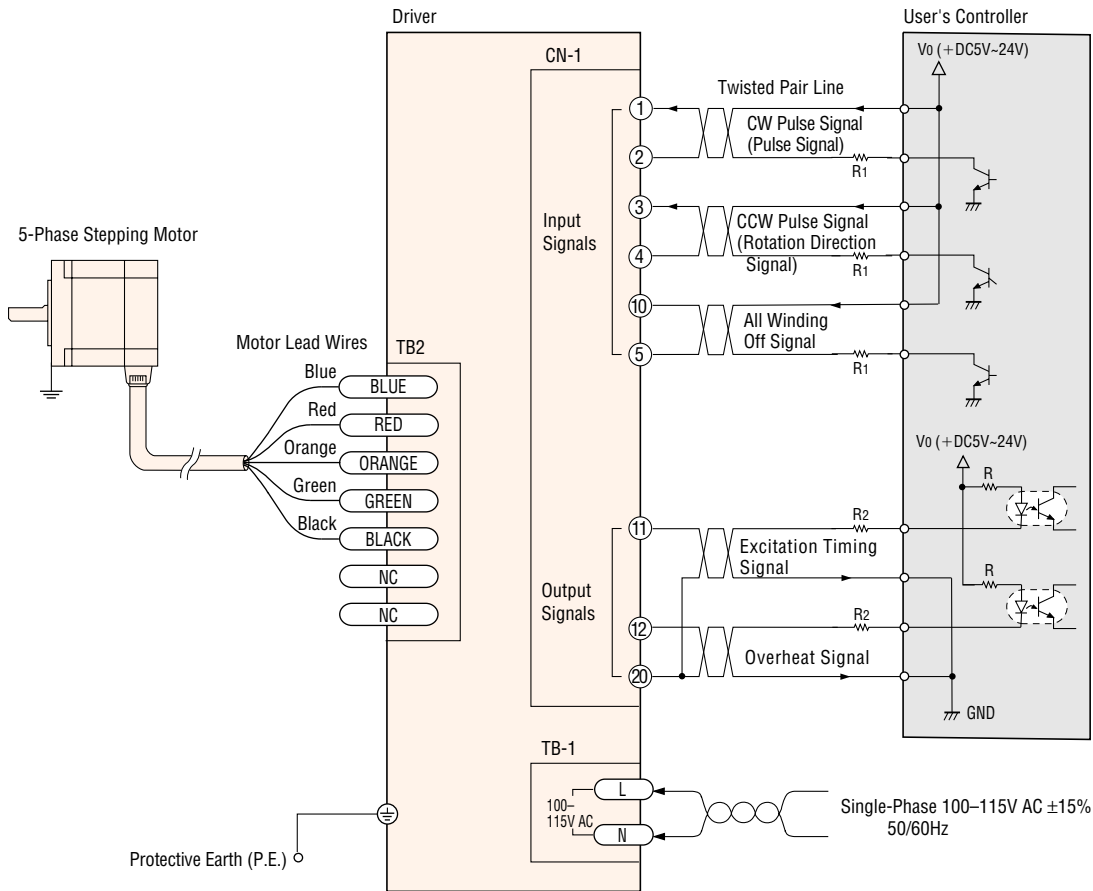

■ Power Supply

Use a power supply that can supply sufficient input current. When power supply capacity is insufficient, a decrease in motor output can cause the following malfunctions:

- Motor does not rotate properly at high-speed (insufficient torque)
- Motor startup and stopping is slow.

Note:

- Keep the voltage V_0 between DC 5V and DC 24V. When they are equal to DC 5V, the external resistances R_1 and R_2 are not necessary. When they are above DC 5V, connect R_1 to keep the current below 20mA, and connect R_2 to keep the current below 10mA.
- Use twisted-pair wire of $3 \times 10^{-4} \text{ in}^2$ (0.2 mm^2) or thicker and 6.6 feet (2m) or less in length for the signal line.
- Use wire $7.8 \times 10^{-4} \text{ in}^2$ (0.5 mm^2) or thicker for motor lines (when extended) and power supply lines, and use $1.2 \times 10^{-3} \text{ in}^2$ (0.75 mm^2) or thicker for the wire for the protective earthing line.
- Use spot grounding for the grounding of the driver and external controller.
- Signal lines should be kept at least 3.94inch (10cm) away from power lines (power supply lines and motor lines). Do not bind the signal line and power line together.

Use open collector transistors (sink type) for the signal output sections of the controller.

⚠ Caution

The driver incorporates double-pole/neutral fusing for the power input. If the driver POWER LED is off, it is possible that only the neutral fuse is tripped. High voltage supplied on the hot side may cause electric shock. Turn the power off immediately and request service.

■ WIRING DIAGRAMS

● Single-Phase 200-230VAC Input

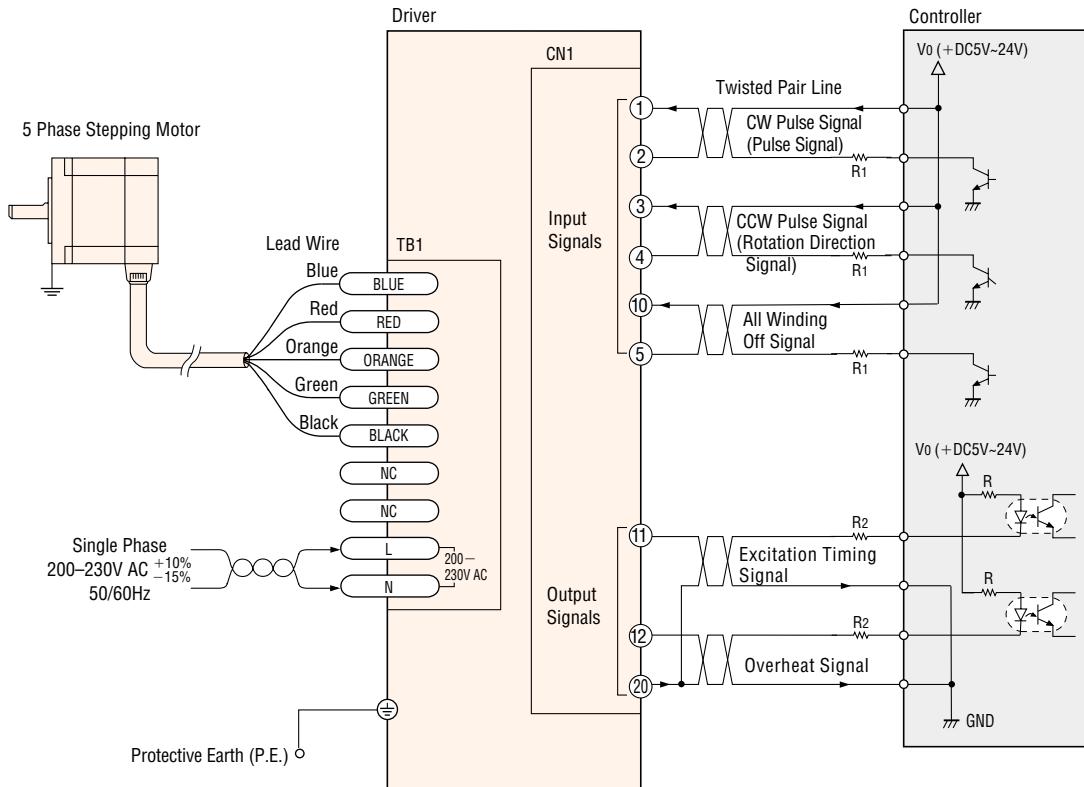

■ Power Supply

Use a power supply that can supply sufficient input current. When power supply capacity is insufficient, a decrease in motor output can cause the following malfunctions:

- Motor does not rotate properly at high-speed (insufficient torque)
- Motor startup and stopping is slow.

Note:

- Keep the voltage V_0 between DC 5V and DC 24V. When they are equal to DC 5V, the external resistances R_1 and R_2 are not necessary. When they are above DC 5V, connect R_1 to keep the current below 20mA, and connect R_2 to keep the current below 10mA.
- Use twisted-pair wire of $3 \times 10^{-4} \text{ in}^2$ (0.2 mm^2) or thicker and 6.6 feet (2m) or less in length for the signal line.
- Use wire $7.8 \times 10^{-4} \text{ in}^2$ (0.5 mm^2) or thicker for motor lines (when extended) and power supply lines, and use $1.2 \times 10^{-3} \text{ in}^2$ (0.75 mm^2) or thicker for the wire for the protective earthing line.
- Use spot grounding for the grounding of the driver and external controller.
- Signal lines should be kept at least 3.94inch (10cm) away from power lines (power supply lines and motor lines). Do not bind the signal line and power line together.

Use open collector transistors (sink type) for the signal output sections of the controller.

⚠ Caution

The driver incorporates double-pole/neutral fusing for the power input. If the driver POWER LED is off, it is possible that only the neutral fuse is tripped. High voltage supplied on the hot side may cause electric shock. Turn the power off immediately and request service.

DESCRIPTION OF INPUT/OUTPUT SIGNALS

1. Pulse Input

Input circuit and sample connection

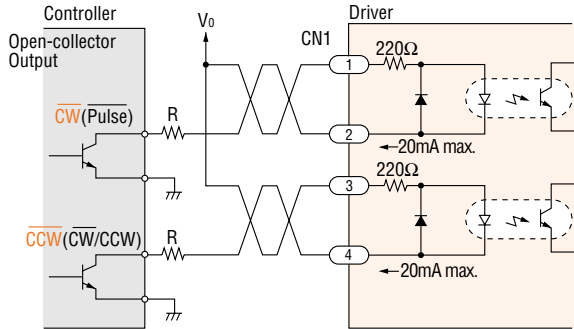

Keep the voltage between DC 5V and DC 24V.
When voltage is equal to DC 5V, external resistance (R) is not necessary. When voltage is above DC 5V, connect external resistance (R) and keep the input current below 20mA.

1. 1-Pulse Input Mode

Pulse Signal

"Pulse" signal is input to the pulse signal terminal. When the photocoupler state changes from "ON" to "OFF", the motor rotates one step. The direction of rotation is determined by the following rotation direction signal.

Rotation Direction Signal

The "Rotation Direction" signal is input to the rotation direction signal input terminal. A "photocoupler ON" signal input commands a clockwise direction rotation. A "photocoupler OFF" signal input commands a counterclockwise direction rotation.

2. 2-Pulse Input Mode

CW Pulse Signal

When the photocoupler state changes from "ON" to "OFF", the motor rotates one step in the clockwise direction.

CCW Pulse Signal

When the photocoupler state changes from "ON" to "OFF", the motor rotates one step in the counterclockwise direction.

CW and CCW refer to clockwise and counterclockwise direction respectively, from a reference point of facing the motor output shaft.

Pulse Waveform Characteristics

(Photocoupler state corresponding the input pulse)

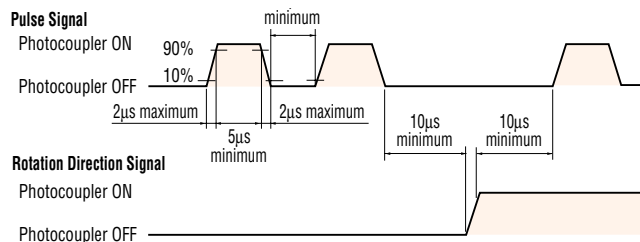

The shaded area indicates when the photocoupler is ON. The motor moves when the photocoupler state changes from ON to OFF as indicated by the arrow.

Pulse Signal Characteristics

- The pulse voltage is 4~5V in the "photocoupler ON" state, and 0~0.5V in the "photocoupler OFF" state.
- Input pulse signals should have a pulse width over 5µs, pulse rise/fall below 2µs, and a pulse duty below 50%.

- Keep the pulse signal at "photocoupler OFF" when no pulse is being input.
- The minimum interval time when changing rotation direction is 10µs. This value varies greatly depending on the motor type, pulse frequency and load inertia. It may be necessary to increase this time interval.
- In 1-pulse input mode, leave the pulse signal at rest ("photocoupler OFF") when changing rotation directions.

2. A.W.OFF (All Windings Off) Input

Input circuit and sample connection

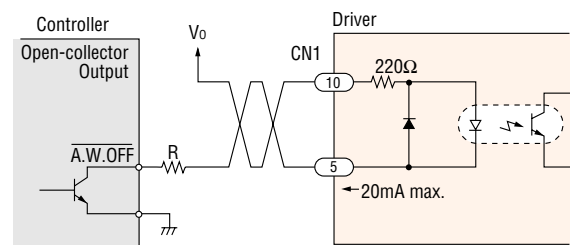

Keep the voltage between DC 5V and DC 24V.
When voltage is equal to DC 5V, external resistance (R) is not necessary. When voltage is above DC 5V, connect external resistance (R) and keep the input current below 20mA.

When the "All Windings Off" signal is in the "photocoupler ON" state, the current to the motor is cut off and motor torque is reduced to zero. The motor output shaft can then be rotated freely by hand.

When the "All Windings Off" signal is in the "photocoupler OFF" state, the motor holding torque is proportional to the current set by the current adjustment rotary switches. During motor operation, be sure to keep the signal in the "photocoupler OFF" state.

This signal is used when moving the motor by external force or manual home position is desired. If this function is not needed, it is not necessary to connect this terminal.

Switching the "All Windings Off" signal from "photocoupler ON" to "photocoupler OFF" does not alter the excitation sequence.

When the motor shaft is manually adjusted with the "All Windings Off" signal input, the shaft will shift up to ±3.6° from the position set after the "All Windings Off" signal is released.

Manual Setting of the Home Position

Input the "All Windings Off" signal, set the motor to the desired position, then release the "All Windings Off" signal.

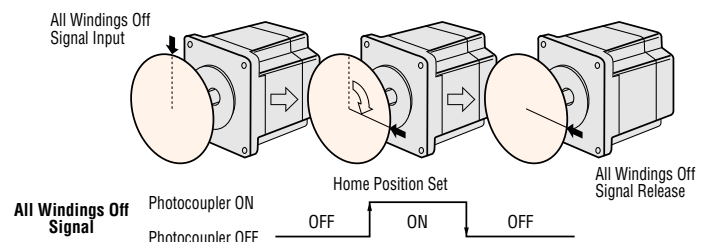

3. TIM. (Excitation Timing) Output

■ Output Circuit and Sample Connection

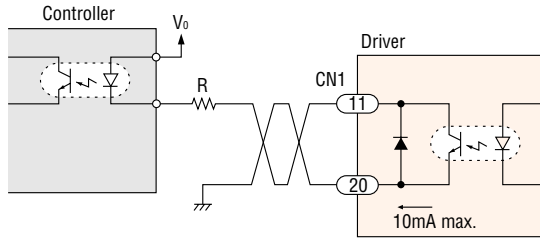

Keep the voltage between DC 5V and DC 24V.
Keep the current below 10mA. If the current exceeds 10mA, connect external resistance (R).

The "Excitation Timing" signal is output to indicate when the motor excitation (current flowing through the winding) is in the initial stage (step "0" at power up).

The "Excitation Timing" signal can be used to increase the accuracy of home position detection by setting the mechanical home position of your equipment (for example, a photo-sensor) to coincide with the excitation sequence initial stage (step "0").

The motor excitation stage changes simultaneously with pulse input, and returns to the initial stage for each 7.2° rotation of the motor output shaft.

When power is turned ON, the excitation sequence is reset to step "0".

The TIM. LED lights when the "Excitation Timing" signal is output. While the motor is rotating, the LED will turn ON and OFF at a high speed and will appear to be continuously lit.

The "Excitation Timing" signal is output simultaneously with a pulse input each time the excitation sequence returns to step "0". The excitation sequence will complete one cycle for every 7.2° rotation of the motor output shaft.

Full Step (the switch is set to F position): Signal is output once every 10 pulses.

Half Step (the switch is set to H position): Signal is output once every 20 pulses.

Timing Chart at Full Step

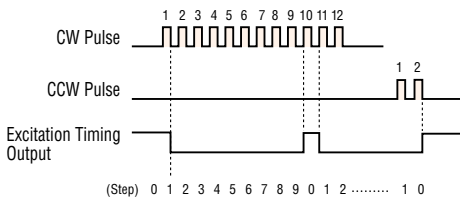

4. O. HEAT (Overheat) Output

■ Output circuit and sample of connection

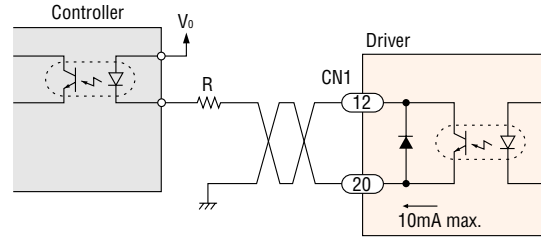

Keep the voltage between DC 5V and DC 24V.
Keep the current below 10mA. If the current exceeds 10mA, connect external resistance (R).

The "Overheat" signal is output to protect the driver from heat damage if the internal temperature of the driver rises above 176°F (80°C).

When connected as shown in the example connection, the signal will be "photocoupler OFF" during normal conditions, and "photocoupler ON" when the temperature exceeds 176°F (80°C).

When the "Overheat" signal is output, turn the driver power OFF, then adjust the operating conditions (ambient temperature, driver/controller settings), or use a fan to cool the driver. After taking appropriate measures, turn the power ON. Turning the power ON will reset the "Overheat" signal and release the "Automatic Current Off" condition.



Artisan Technology Group is your source for quality new and certified-used/pre-owned equipment

- FAST SHIPPING AND DELIVERY
- TENS OF THOUSANDS OF IN-STOCK ITEMS
- EQUIPMENT DEMOS
- HUNDREDS OF MANUFACTURERS SUPPORTED
- LEASING/MONTHLY RENTALS
- ITAR CERTIFIED SECURE ASSET SOLUTIONS

SERVICE CENTER REPAIRS

Experienced engineers and technicians on staff at our full-service, in-house repair center

*InstraView*SM REMOTE INSPECTION

Remotely inspect equipment before purchasing with our interactive website at www.instraview.com ↗

WE BUY USED EQUIPMENT

Sell your excess, underutilized, and idle used equipment. We also offer credit for buy-backs and trade-ins. www.artisanng.com/WeBuyEquipment ↗

LOOKING FOR MORE INFORMATION?

Visit us on the web at www.artisanng.com ↗ for more information on price quotations, drivers, technical specifications, manuals, and documentation

Contact us: (888) 88-SOURCE | sales@artisanng.com | www.artisanng.com