



Artisan Technology Group is your source for quality new and certified-used/pre-owned equipment

- FAST SHIPPING AND DELIVERY
- TENS OF THOUSANDS OF IN-STOCK ITEMS
- EQUIPMENT DEMOS
- HUNDREDS OF MANUFACTURERS SUPPORTED
- LEASING/MONTHLY RENTALS
- ITAR CERTIFIED SECURE ASSET SOLUTIONS

SERVICE CENTER REPAIRS

Experienced engineers and technicians on staff at our full-service, in-house repair center

*InstraView*SM REMOTE INSPECTION

Remotely inspect equipment before purchasing with our interactive website at www.instraview.com ↗

WE BUY USED EQUIPMENT

Sell your excess, underutilized, and idle used equipment. We also offer credit for buy-backs and trade-ins. www.artisanng.com/WeBuyEquipment ↗

LOOKING FOR MORE INFORMATION?

Visit us on the web at www.artisanng.com ↗ for more information on price quotations, drivers, technical specifications, manuals, and documentation

Contact us: (888) 88-SOURCE | sales@artisanng.com | www.artisanng.com

- High-speed, easy-to-use fiber-optic network (1.2 Gbaud serially)
- Data written to memory in one node is also written to memory in all nodes on the network
- Up to 256 nodes
- Connection with multimode fiber up to 1,000 ft; single-mode fiber up to 10 km or twinax cable up to 30 m
- Data transferred at 29.5 Mbyte/s without redundant transfer
- Data transferred at 14.8 Mbyte/s with redundant transfer
- Any node on the network can generate an interrupt in any other node on the network or in all network nodes with a single command
- Error detection
- Redundant transmission mode for suppressing errors
- No processor overhead
- No processor involvement in the operation of the network
- Up to 16 Mbyte of Reflective Memory
- D32:D16:D8 memory access
- Single PCI 5 V slot, standard long card
- PCI target data bursts supported with 44 Mbyte/s transfer rates
- PCI master DMA controller (optional). DMA transfer rates of 132 Mbyte/s maximum and 33 Mbyte/s sustained.
- Configurable endian conversions for multiple CPU architectures on the network
- Communication link compatible with VMIVME-5588 and VMIPMC-5588
- Software-addressable digital output bit available at output connector for use with optical switch board or any user-defined purpose
- Windows NT® OS driver available which operates the VMIPCI-5588 as a network interface board. Allows TCP/IP and other protocol connectivity on a network of VMIPCI-5588 or VMIVME-5588 nodes.

INTRODUCTION — VMIPCI-5588 is a high-performance, daisy-chained PCI-to-PCI network. Data is transferred by writing to on-board global RAM. The data is automatically sent to the location in memory on all Reflective Memory boards on the network. The Reflective Memory network can include both PCI and VME systems. Data can be shared in VMEbus systems with the network-compatible VMIVME-5588.

PRODUCT OVERVIEW — The Reflective Memory concept provides a very fast and efficient way of sharing data across distributed computer systems.

VMIC's VMIPCI-5588 Reflective Memory interface allows data to be shared between up to 256 independent systems (nodes) at rates up to 29.5 Mbyte/s. Each Reflective Memory board may be configured with 256 Kbyte to 16 Mbyte of on-board SRAM. The local SRAM provides fast Read access times to stored data. Writes are stored in local SRAM and broadcast over a high-speed fiber-optic data path to other Reflective Memory nodes. The transfer of data between nodes is software transparent, so no I/O overhead is required. Transmit and Receive FIFOs buffer data during peak data rates to optimize CPU and bus performance to maintain high data throughput.

The Reflective Memory also allows interrupts to one or more nodes by writing to a byte register. These interrupt (three levels, each user definable) signals may be used to synchronize a system process, or used to follow any data. The interrupt always follows the data to ensure the reception of the data before the interrupt is acknowledged.

The VMIPCI-5588 requires no initialization unless the user desires to use interrupts, endian byte swapping, or an external mode bypass switch such as the VMIVME-5591.

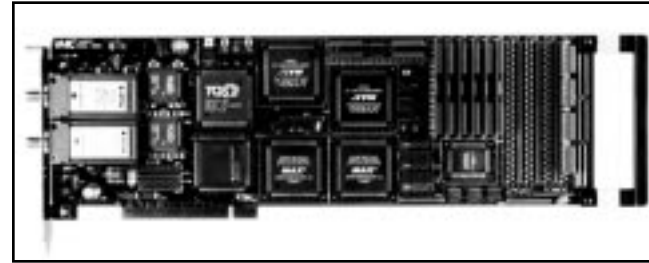

Each node on the system has a unique identification number between 0 and 255. The node number is established during hardware system integration by placement of jumpers on the board. This node number can be read by software by accessing an on-board register. In some applications, this node number would be useful in establishing the function of the node.

In order to achieve an aggregate throughput of 29.5 Mbyte/s, nodes capable of writing to the Reflective Memory network at an aggregate rate of 29.5 Mbyte/s must be present.

LINK ARBITRATION — The VMIPCI-5588 system is a fiber-optic or twinax daisy chain ring as shown in Figure 1. Each transfer is passed from node-to-node until it has gone all the way around the ring and reaches the originating node. Each node retransmits all transfers that it receives except those that it originated. Nodes are allowed to insert transfers between transfers passing through.

INTERRUPT TRANSFERS — In addition to transferring data between nodes, the VMIPCI-5588 will allow any processor in any node to generate an interrupt on any other node. These interrupts would generally be used to indicate to the receiving node that new data has been sent and is ready for processing. These interrupts are also used to indicate that processing of old data is completed and the receiving node is ready for new data.

Three interrupts are available. The user may define the function for each interrupt. Any processor can generate an interrupt on any other node on the network. In addition, any processor on the network can generate an interrupt on all nodes on the network. Interrupts are generated by simply writing to a VMIPCI-5588 register.

All data and interrupt command transfers contain the node number of the node that originated the transfer. This information is used primarily so the originating node can remove the transfer from the network after the transfer has traversed the ring. The node identification is also used by nodes receiving interrupt commands. When a node receives an interrupt command for itself, it places the identification number of the originating node in a FIFO. Up to 512 interrupts can be stacked in the FIFO. During the interrupt service routine, the identification of the interrupting node can be read from the FIFO.



Ordering Options																																								
January 14, 1998 800-855588-000 E																																								
	A	B	C	-	D	E	F																																	
VMIPCI-5588	-			-																																				
A = Memory Options 0 = 256 Kbyte 1 = 512 Kbyte 2 = 1 Mbyte 3 = 2 Mbyte 4 = 4 Mbyte 5 = 8 Mbyte 6 = 16 Mbyte B = FIFO Option 0 = 512 Transfer FIFO 1 = 4 Kbyte Transfer FIFO C = Transmission Mode <table border="1"> <thead> <tr> <th>Transmit</th> <th>Receive</th> <th>Mode</th> </tr> </thead> <tbody> <tr> <td>0 = Reserved</td> <td></td> <td></td> </tr> <tr> <td>1 = mm Fiber</td> <td>mm Fiber</td> <td>Multimode DMA</td> </tr> <tr> <td>2 = sm Fiber</td> <td>sm Fiber</td> <td>Single-Mode DMA</td> </tr> <tr> <td>3 = mm Fiber</td> <td>sm Fiber</td> <td>Mixed-Mode DMA</td> </tr> <tr> <td>4 = sm Fiber</td> <td>mm Fiber</td> <td>Mixed-Mode DMA</td> </tr> <tr> <td>5 = Twinax</td> <td>Twinax</td> <td>Cable DMA</td> </tr> <tr> <td>6 = Twinax</td> <td>mm Fiber</td> <td>Mixed DMA</td> </tr> <tr> <td>7 = Twinax</td> <td>sm Fiber</td> <td>Mixed DMA</td> </tr> <tr> <td>8 = mm Fiber</td> <td>Twinax</td> <td>Mixed DMA</td> </tr> <tr> <td>9 = sm Fiber</td> <td>Twinax</td> <td>Mixed DMA</td> </tr> </tbody> </table>								Transmit	Receive	Mode	0 = Reserved			1 = mm Fiber	mm Fiber	Multimode DMA	2 = sm Fiber	sm Fiber	Single-Mode DMA	3 = mm Fiber	sm Fiber	Mixed-Mode DMA	4 = sm Fiber	mm Fiber	Mixed-Mode DMA	5 = Twinax	Twinax	Cable DMA	6 = Twinax	mm Fiber	Mixed DMA	7 = Twinax	sm Fiber	Mixed DMA	8 = mm Fiber	Twinax	Mixed DMA	9 = sm Fiber	Twinax	Mixed DMA
Transmit	Receive	Mode																																						
0 = Reserved																																								
1 = mm Fiber	mm Fiber	Multimode DMA																																						
2 = sm Fiber	sm Fiber	Single-Mode DMA																																						
3 = mm Fiber	sm Fiber	Mixed-Mode DMA																																						
4 = sm Fiber	mm Fiber	Mixed-Mode DMA																																						
5 = Twinax	Twinax	Cable DMA																																						
6 = Twinax	mm Fiber	Mixed DMA																																						
7 = Twinax	sm Fiber	Mixed DMA																																						
8 = mm Fiber	Twinax	Mixed DMA																																						
9 = sm Fiber	Twinax	Mixed DMA																																						
Multimode Fiber-Optic Cable Assemblies																																								
	A	B	C	-	D	E	F																																	
VMICBL-000-F3	-		0	-																																				
A = Fiber-Optic Connector Type 0 = Ceramic Ferrule St Connector 1 = Stainless Steel Ferrule St Connector BC = Cable Lengths 00 = Not Used 01 = 5 ft (1.5 m) 02 = 25 ft (7.6 m) 03 = 50 ft (15.2 m) 04 = 100 ft (30.4 m) 05 = 150 ft (45.7 m) 06 = 200 ft (60.9 m) 07 = 350 ft (106.7 m) 08 = 500 ft (152.4 m) 09 = 1,000 ft (304.8 m)																																								
Twinax Cable Assemblies																																								
	A	B	C	-	D	E	F																																	
VMICBL-001-33	-	0		-																																				
A = 0 (Option reserved for future use) BC = Cable Lengths 00 = Not used 01 = 0.5 m 02 = 1 m 03 = 3 m 04 = 5 m 05 = 7 m 06 = 10 m 07 = 15 m 08 = 20 m 09 = 25 m 10 = 30 m																																								
For Ordering Information, Call: 1-800-322-3616 or 1-256-880-0444 • FAX (256) 882-0859 E-mail: info@vmic.com Web Address: www.vmic.com Copyright © April 1995 by VMIC Specifications subject to change without notice.																																								

PCI INITIATOR/DMA CAPABILITIES — The DMA capability is initiated by a PCI host. After the DMA engine is initialized by a host, the VMIPCI-5588 will request the PCI bus as appropriate and move up to 16 Mbyte as a PCI initiator. This capability removes the CPU from the responsibility of requesting the PCI bus and moving the data itself. This feature is very useful for moving large blocks of data. The PCI architecture ensures that the VMIPCI-5588 does not monopolize the PCI bus during this process. Large DMA blocks will automatically be split into smaller bursts on the PCI bus by the DMA engine. The VMIPCI-5588 can be programmed to issue a PCI interrupt at the conclusion of a DMA transfer or the host can poll the status of the DMA process. Although the DMA engine can do both DMA reads and DMA writes, they cannot occur simultaneously. The VMIPCI-5588 can burst data onto the PCI bus at a maximum rate of 132 Mbyte/s and a sustained rate of 33 Mbyte/s. If the target operates at a slower rate, the PCI handshaking capabilities will throttle the data rate.

ERROR MANAGEMENT — Errors are detected by the VMIPCI-5588 with the use of the error detection facilities of the Fiber Channel encoder/decoder and additional interlaced parity encoding and checking. When a node detects an error, the erroneous transfer is removed from the system and a PCI bus interrupt is generated, if enabled. The error rate of the VMIPCI-5588 is a function of the rate of errors produced in the optical portion of the system. This optical error rate depends on the length and type of fiber-optic cable. Assuming an optical error rate of 10^{-12} , the error rate of the VMIPCI-5588 is 1.6×10^{-10} transfers/transfer.

The VMIPCI-5588 can be operated in a redundant transfer mode in which each transfer is transmitted twice. In this mode of operation, the first of the two transfers is used unless an error is detected in which case the second transfer is used. In the event that an error is detected in both transfers, the node removes the transfer from the system. The probability of both transfers containing an error is 2.56×10^{-20} , or about one error every 330,300 years at maximum data rate.

ENDIAN CONVERSIONS — Data lane steering can be configured in a Control Register to allow CPUs of different architectures to communicate. Byte swap, Word swap, and Byte-Word swap options are available.

PROTECTION AGAINST LOST DATA — Data received by the node from the cable is error checked and placed in a receive FIFO. Arbitration with accesses from the PCI bus then takes place, and the data is written to the node's SRAM and to the node's transmit FIFO. Data written to the board from the PCI bus is placed directly into SRAM and into the transmit FIFO. Data in the transmit FIFO is transmitted by the node over the fiber-optic cable to the next node. Data could be lost if either FIFO were allowed to become full.

The product is designed to prevent either FIFO from becoming full and overflowing. It is important to note the only way that data can start to accumulate in FIFOs is for data to enter the node at a rate greater than 29.5 Mbyte/s or 14.8 Mbyte/s in redundant mode. Since data can enter from

the cable and from the PCI bus, it is possible to exceed these rates. If the transmit FIFO becomes half-full, a bit in the Status Register is set. This is an indication to the node's software that subsequent WRITES to the Reflective Memory should be suspended until the FIFO is less than half-full. If the half-full indication is ignored and the transmit FIFO becomes full, then writes to the Reflective Memory will be acknowledged with a STOP*. No data will be lost.

If the receive FIFO is allowed to become over half-full, there is a danger the receiver FIFO may overflow resulting in data loss. In order to prevent this situation, all PCI writes will be acknowledged by a STOP* until the receive FIFO is less than half-full.

NETWORK MONITOR — There is a bit in a Status Register that can be used to verify that data is traversing the ring (that is, the ring is not broken). This can also be used to measure network latency.

SPECIFICATIONS

Memory Size: 256 Kbyte, 512 Kbyte, 1 Mbyte, 2 Mbyte, 4 Mbyte, 8 Mbyte, or 16 Mbyte

PCI Transfer Rate: 44 Mbyte/s as a Target. As DMA initiator: 132 Mbyte/s maximum, 33 Mbyte/s sustained.

TRANSFER SPECIFICATION

Transfer Rate: 29.5 Mbyte/s (longword accesses) without redundant transfer
14.7 Mbyte/s (longword accesses) with redundant transfer

CABLES

VMIC offers the following cable assemblies that are compatible with the VMIPCI-5588.

Multimode Fiber Cable:

ST connectors
1,000 feet maximum
62.5 micron core
10 dB maximum attenuation between nodes
Wavelength = 860 nm

Twinax Cable:

9-pin D-type connector
Equalized, 30 m maximum

The VMIPCI-5588 is compatible with single-mode fiber with SC connectors and a maximum of 10 km. VMIC does not supply single-mode fiber cable.

COMPATIBILITY

Reflective Memory Products: The VMIPCI-5588 is compatible with VMIC's line of Reflective Memory products which include VMIVME-5588 VMEbus-based

Reflective Memory and the VMIPMC-5588 PMC bus-based boards. The 5588 Series of products has auxiliary products which include the VMIVME-5591 Active Fiber-Optic Bypass Switch which is utilized to bypass nodes in a system with effectively 0.0 dB insertion loss, and the VMIVME-5592 which is utilized to allow the 1,000 ft fiber-optic cable length limit to be extended to 10 km.

Memory: The 256 Kbyte, 512 Kbyte, and 1 Mbyte memory options of the VMIPCI-5588 all use 1 Mbyte of address space to locate data in the local node. Since the PCI bus is an automapped bus, all of these memory options must occupy 1 Mbyte of memory space on the PCI bus. This mapping structure allows these options to be compatible with VMIVME-5588 Reflective Memories of size 1 Mbyte and smaller.

The 2 and 4 Mbyte memory options of the VMIPCI-5588 both use 4 Mbyte of address space to locate data in the local node. Both of these memory options must occupy 4 Mbyte of memory space on the PCI bus. This mapping structure allows these options to be compatible with VMIVME-5588 Reflective Memories of size 2 and 4 Mbyte.

The 8 and 16 Mbyte memory options of the VMIPCI-5588 both use 16 Mbyte of address space to locate data in the local node. Both of these memory options must occupy 16 Mbyte of memory space on the PCI bus. This mapping structure allows these options to be compatible with VMIVME-5588 Reflective Memories of size 8 and 16 Mbyte.

SOFTWARE DRIVER

A Windows NT OS driver for the VMIPCI-5588 is available. The driver operates the VMIPCI-5588 as a network interface board. A portion of the Reflective Memory is reserved by the driver for network use, and the remainder of memory is available as simple user-shared memory. When used as a network interface board, the VMIPCI-5588 has a dual role; the board provides both network connectivity as well as fast shared memory for distributed applications.

The driver is NDIS compliant and supports the protocols configured into the Windows NT OS system including TCP/IP. For more information, see the VMIVME/SW-5588 specification.

PHYSICAL/ENVIRONMENTAL

Temperature Range: 0 to 65 °C, operating with forced air cooling. -40 to 85 °C, storage.

Relative Humidity: 20 to 80 percent, noncondensing

Power Requirements: 5.0 A maximum at +5 VDC

DATA TRANSFERS

Data written into the Reflective Memory is broadcast to all nodes on the network without further involvement of the sending or receiving nodes. Data is transferred from memory locations on the sending nodes to corresponding memory locations on the receiving nodes.

A functional block diagram of the VMIPCI-5588 is shown in Figure 2.

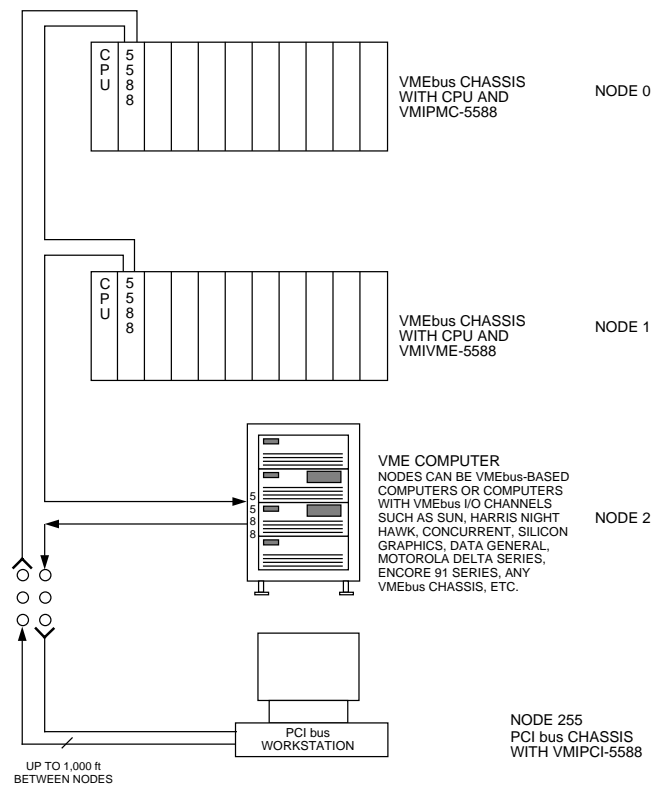
TRADEMARKS

Windows NT is a registered trademark of Microsoft Corporation. Other registered trademarks are the property of their respective owners.

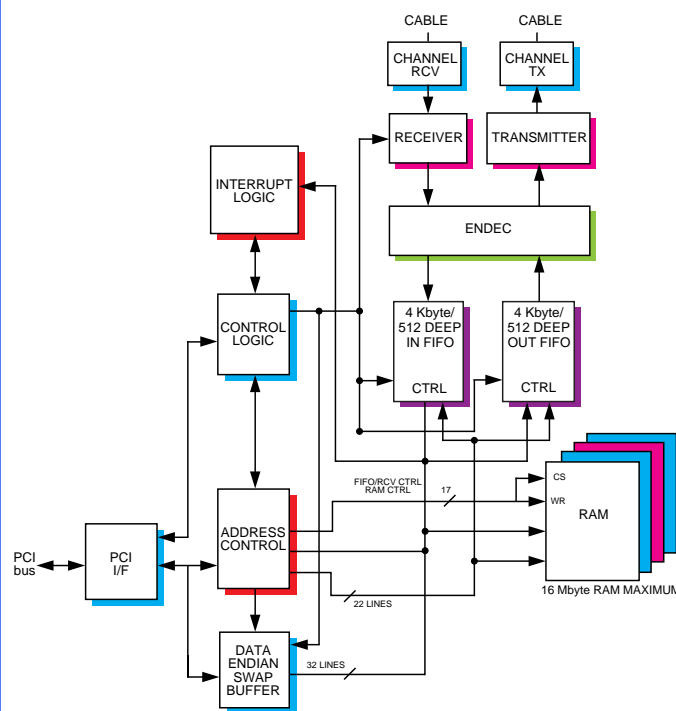



Artisan Technology Group is your source for quality new and certified-used/pre-owned equipment

- FAST SHIPPING AND DELIVERY
- TENS OF THOUSANDS OF IN-STOCK ITEMS
- EQUIPMENT DEMOS
- HUNDREDS OF MANUFACTURERS SUPPORTED
- LEASING/MONTHLY RENTALS
- ITAR CERTIFIED SECURE ASSET SOLUTIONS

SERVICE CENTER REPAIRS

Experienced engineers and technicians on staff at our full-service, in-house repair center

*InstraView*SM REMOTE INSPECTION

Remotely inspect equipment before purchasing with our interactive website at www.instraview.com ↗

WE BUY USED EQUIPMENT

Sell your excess, underutilized, and idle used equipment. We also offer credit for buy-backs and trade-ins. www.artisanng.com/WeBuyEquipment ↗

LOOKING FOR MORE INFORMATION?

Visit us on the web at www.artisanng.com ↗ for more information on price quotations, drivers, technical specifications, manuals, and documentation

Contact us: (888) 88-SOURCE | sales@artisanng.com | www.artisanng.com