



Artisan Technology Group is your source for quality new and certified-used/pre-owned equipment

- FAST SHIPPING AND DELIVERY
- TENS OF THOUSANDS OF IN-STOCK ITEMS
- EQUIPMENT DEMOS
- HUNDREDS OF MANUFACTURERS SUPPORTED
- LEASING/MONTHLY RENTALS
- ITAR CERTIFIED SECURE ASSET SOLUTIONS

SERVICE CENTER REPAIRS

Experienced engineers and technicians on staff at our full-service, in-house repair center

*InstraView*SM REMOTE INSPECTION

Remotely inspect equipment before purchasing with our interactive website at www.instraview.com ↗

WE BUY USED EQUIPMENT

Sell your excess, underutilized, and idle used equipment. We also offer credit for buy-backs and trade-ins. www.artisanng.com/WeBuyEquipment ↗

LOOKING FOR MORE INFORMATION?

Visit us on the web at www.artisanng.com ↗ for more information on price quotations, drivers, technical specifications, manuals, and documentation

Contact us: (888) 88-SOURCE | sales@artisanng.com | www.artisanng.com

- Four-channel analog waveform generator
- Autocalibration of all channels
- Continuous, single burst, or burst/idle/burst waveform generation modes of operation
- One 16-bit D/A converter per output
- Programmable per channel internal or external sample clock
- Up to 2.5 million samples/second
- External clock and trigger input per channel
- Variable length (up to 65,536 word) waveform buffer per channel
- Bipolar 2.5, 5.0, and 10.0 V ranges programmable per channel and unipolar 0 to 5, 0 to 10 programmable
- 10 mA output drive current per channel
- 0.8 Ω output impedance
- Deglitched DAC outputs with optional 4-pole low pass filtering
- External sync output (per channel)
- On-board digital signal processor and 20-bit analog-to-digital converter for automatic calibration and diagnostic self-test
- Field wiring disconnect for off-line self-test diagnostics
- Front panel reference voltage access
- Remote ground sense - pseudo-differential outputs
- Filter modules

APPLICATIONS

- Data acquisition systems
- Control systems
- Precision analog stimulus
- Automatic test equipment (ATE)

INTRODUCTION — The VMIVME-4145 Analog Output Board provides four high-quality analog output channels with 16-bit resolution. Each output has a dedicated D/A Converter (DAC), and can source or sink 10 mA at ± 10 V. The analog outputs can be disconnected from the field wiring for off-line testing. Autocalibration and self-test are initiated by a VMEbus system reset or by execution of a software command. An on-board Digital Signal Processor (DSP) and a 20-bit Analog-to-Digital Converter (ADC) are used to calibrate the offset and gain of the DAC. During calibration, a table of offset and gain coefficients is compiled and stored in RAM. There is an entry for offset and gain corresponding to each of the four channels configured in each of the five output voltage ranges.

FUNCTIONAL CHARACTERISTICS

VMEbus Compliance: This board complies with the VMEbus specification (ANSI/IEEE STD1014-1987 IEC 821 and 297) with the following mnemonics:
 Addressing Mode Responding Address Modifiers
 A32 \$09 (Extended nonprivileged data access) or \$0D (Extended supervisory data access)
 A24 \$39 (Standard nonprivileged data access) or \$3D (Standard supervisory data access)
 Data Access: D16, D08 (EO)

Board Address: The base VMEbus address is set by configuration of a jumper field. A jumper exists for each of the addresses A31 through A17; thus, the address space occupied by this board is 128 Kbyte.

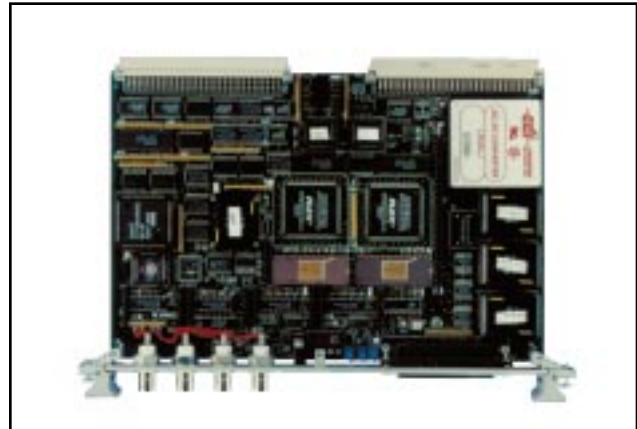

VMEbus Access: Address modifier bits are jumper selected and decoded to support nonprivileged, supervisory, and either nonprivileged or supervisory board accesses.

Waveform Generation: Waveform data is entered through a 64 k word waveform sample buffer. The buffer size is programmable from 2 to 65,536. The user configures a channel for either continuous, single burst, or continuous burst/idle/burst mode. The local DSP applies gain and offset correction to the waveform samples and then stores them in a channel waveform buffer (not accessible by VMEbus). Waveform generation begins with either a software trigger or an external trigger input. Each channel may use either an internal or external clock timebase input. During waveform generation, the trigger input is retriggerable and will restart an active waveform to the first location of the waveform table.

Ordering Options							
Sept. 24, 1998 800-004145-000 D	A	B	C	-	D	E	F
VMIVME-4145	-		0	-			
A = Filter Boards 0 = No Filter 1 = 500 kHz Chebyshev 2 = 1 MHz Chebyshev 3 = 500 kHz Bessel 4 = 1 MHz Bessel B = 0 (Option reserved for future use) C = Number of Channels 0 = 4 Channels 1 = 2 Channels							
Front Panel Waveform Output, Reference Voltage, and External Clock/Sync Connector Data							
BNC: AMP No. 1-227079-5							
For Ordering Information, Call: 1-800-322-3616 or 1-256-880-0444 • FAX (256) 882-0859 E-mail: info@vmic.com Web Address: www.vmic.com Copyright © October 1994 by VMIC Specifications subject to change without notice.							

Self-Test: Self-test is run automatically after a system reset. A Self-Test Register indicates the success or failure of each channel.

System Reset: After a system reset, all outputs are in the off-line mode, all Control Registers are in their default state, self-test is initiated, and ADC autocalibration is initiated.

Front Panel Status LED: This indicator is illuminated after a system reset and is extinguished upon the successful completion of self-test and autocalibration. The LED can also be turned on and off under software control.

Front Panel Reference Voltage Access: A connector on the front panel allows access for measuring the reference voltages. Located below the reference voltage connector is a front panel access port to the reference voltage adjustment. Autocalibration is based on this precision voltage reference.

Calibration: When autocalibration is initiated by software command, an embedded DSP loads calibration output values into each of the output DACs which are read back into the DSP through a 20-bit Sigma Delta ADC. This is repeated until a sufficient number of calibration points have been measured. A calibration table consisting of offset and gain corrections for each of the four outputs in each of the six voltage ranges is compiled and stored in RAM. These correction factors are recalled when the waveform sample buffer is processed.

Address Map (Offset from Base Address):

COMMAND AND STATUS REGISTERS	\$0 0000
RESERVED	\$0 2000
WAVEFORM BUFFER (56K)	\$0 4000 \$1 FFFE

64 K RAM Memories: The board contains five separate 64 K x 16 RAM memories. The first is common and shared between the VMEbus and the on-board DSP processor. The user downloads the waveform into this common memory. The DSP then applies calibration and moves this waveform data into one of the four dedicated channel DAC RAM memories.

Segmentation: Segmentation allows the user to switch waveform outputs in real-time. The user may segment the 64 K waveform space into multiple waveforms. A maximum of 64 waveforms of 1,024 words each may be programmed. In real-time, the user may switch between any of these waveforms or program an automatic sequencing of these. Each waveform is generated start to finish, and the next is seamlessly started. A link list approach can be programmed in real-time by the VMEbus host processor.

Sweep Frequency Operation: The board's internal sample rate clock may be changed in real-time while a waveform is being generated. This host control allows the waveform to be swept across a range of frequencies. See the example on page 5 for calculating the accuracy of a swept signal (25 ns resolution). This feature requires real-time host interaction.

ELECTRICAL CHARACTERISTICS

(At +25 °C and rated power supplies unless otherwise noted.)

Outputs: Four single-ended Analog outputs. One DAC per output channel.

Full-Scale Output: ±10 V, ±5 V, ±2.5 V, 0 to +5 V, or 0 to +10 V

Output Code: Each 16-bit DAC accepts digital codes in two's complement or offset binary (software selectable)

Resolution: 16 bits

External Sample Clock: 400 ns period (minimum)

External Trigger: 50 ns (minimum width)

Internal Timebase: 40 MHz

Stability: ±10 PPM

Internal Programmable Sample Clock: 400 ns to 1.52 ms (with 25 ns resolution)

External Clock and Trigger Input Buffer:

Logic: Inverting schmidt-trigger
 Propagation Delay: tpd @ 25 °C = 31 ns
 Input Voltage: Vh = 3.15 V, V1 = 0.9 V

Waveform Buffer Size: 2 to 65,536 samples per channel

Burst Period: 2²⁴ Sample Clocks maximum

Trigger Latency: 300 ns

Output Impedance: <0.8 Ω, on-line
>10 MΩ, off-line

Output Current: ±10 mA, over the entire output voltage range

Output Short Circuit Protection: 30 second short to common
Transient overvoltage protected to ±14 V for 1 s

TRANSFER CHARACTERISTICS

Transfer Function:

$$E_{OUT} = E_{OUTMIN} + \left(\frac{N_{DATA}}{65,536} \times E_{SPAN} \right)$$

Where:

E_{OUT} = Channel output Voltage

E_{OUTMIN} = Negative end of the range

N_{DATA} = Channel data from the VMEbus

E_{SPAN} = Positive end of the range minus the Negative end of the range

Example: for the ±5 V range:

$$E_{OUT} = -5 V + \left(\frac{N_{DATA}}{65,536} \times 10 V \right)$$

Transfer Time⁴:

Calibrated Waveform Timing Summary

N	VME (ms)+	DSP (ms) =	TOT (ms)	Per sample (µs)
10	0.26	1.54	1.80	180.40
100	1.24	2.85	4.09	40.92
1,000	11.06	15.99	27.05	27.05
10,000	109.16	144.50	253.66	25.37
20,000	218.15	274.51	492.66	24.63
30,000	327.15	404.52	731.67	24.39
40,000	436.16	534.53	970.68	24.27
50,000	545.16	664.54	1209.70	24.19

Uncalibrated Waveform Timing Summary

N	VME (ms)+	DSP (ms) =	TOT (ms)	Per sample (µs)
10	0.27	0.22	0.49	48.80
100	1.25	1.13	2.38	23.76
1,000	11.05	10.22	21.27	21.27
10,000	109.15	99.14	208.29	20.83
20,000	218.16	189.14	407.30	20.36
30,000	327.16	279.15	606.31	20.21
40,000	436.16	369.16	805.32	20.13
50,000	545.15	459.17	1004.32	20.09

Differential Nonlinearity: 0.005 percent of FSR maximum. Monotonic over the operating temperature range.

Integral Nonlinearity: 0.007 percent of FSR maximum

Dynamic Range: 80 dB³

Signal-to-Noise Ratio: 83 dB³

Initial Voltage Accuracy^{1,3}:
VMIVME-4145-001 2-Channel, Channels 0 to 1

Range	Gain Error (% setting)	+ Offset/Nonlinearity Error (% span)	+ Fixed
±2.5	±0.005	±0.018	±250 µV
±5.0	±0.005	±0.018	±250 µV
±10.0	±0.005	±0.018	±250 µV
0-5.0	±0.005	±0.018	±250 µV
0-10.0	±0.005	±0.018	±250 µV

VMIVME-4145-000 4-Channel, Channels 2 to 3

Range	Gain Error (% setting)	+ Offset/Nonlinearity Error (% span)	+ Fixed
±2.5	±0.005	±0.018	±500 µV
±5.0	±0.005	±0.018	±500 µV
±10.0	±0.005	±0.018	±500 µV
0-5.0	±0.005	±0.018	±500 µV
0-10.0	±0.005	±0.018	±500 µV

Example: For a setting of +2.000 V on the ±5 VDC (10 V span) output range for channel zero:

$$\begin{aligned} \text{Accuracy} &= (\pm 0.005\% \times 2.00 \text{ V}) \pm (0.018\% \times 10 \text{ V}) \pm 250 \mu\text{V} \\ &= 100 \mu\text{V} + 1.8 \text{ mV} + 250 \mu\text{V} = \pm 2.1 \text{ mV} \end{aligned}$$

Voltage Accuracy Stability³:

Temperature Effects: ±35 PPM of Setting ±25 PPM of Span ±30 µV maximum drift per °C.

Long Term: ±45 PPM of Setting ±30 PPM of Span ±50 µV, maximum drift per 1,000 hr

Interchannel Crosstalk Rejection: 80 dB minimum, DC to 10.0 kHz³

Output Noise²: 2 mVp-p maximum at 3σ, 10 Hz to 10 kHz

Transition Impulse: 5 µV - s, maximum spike during data transitions

WAVEFORM FREQUENCY ACCURACY — The frequency of a programmed waveform and its accuracy are dependent on the number of samples downloaded to represent it and the timebase used to clock out each sample. The more samples used to represent a waveform and the finer the resolution of the clock, the more accurate the generated frequency will be.

Number of Samples in Table:

Minimum: 10 to 100 (suggested)
Maximum: 65,536

Internal Programmable Sample Clock:

Period: 400 ns to 2.62 ms
Frequency: 2.5 MHz to 657.89 Hz
Resolution (Step Size): 25 ns (for example, 400 ns, 425 ns, 450 ns . . .)
System Timebase: 40 MHz oscillator ±100 PPM

External Sample Clock (User Supplied):

Maximum Frequency (User Provided): 2.5 MHz
Minimum Period: 400 ns
Resolution: Limited to user-supplied signal

Software Clock:

Maximum Frequency: 2.5 MHz
Maximum Period: 400 ns
Minimum Period: Infinite
Resolution: Limited to CPU speed and firmware

The software clock lets the host computer take control of the sample clock. This may be used for extremely long waveform periods.

Frequency of Waveform: The following formulas are used to calculate the frequency and number of samples for a waveform:

A)

$$\text{Freq (Hz)} = \frac{1}{(\# \text{ samples in table}) \times (\text{sample clock period})}$$

Where:
samples = 1 to 65,536
sample clock period = 400 ns to 1.5 ms in 25 ns steps

B)

$$\# \text{ samples required} = \frac{\text{frequency of sample clock}}{\text{frequency desired}}$$

Example 1:

How many samples are required to generate a 1 kHz sine wave using the fastest output sample clock frequency?

$$\# \text{ samples} = 2.5 \text{ MHz} / 1,000 \text{ kHz} = 2,500 \text{ samples}$$

Example 2:

A sinusoidal waveform is 100 samples in length. What is the fastest frequency that can be generated? If the frequency is to be swept, what is the sweep frequency resolution?

$$f = 1/(100) \times (400 \text{ ns}) = 25 \text{ kHz}$$

The internal timebase works on 25 ns steps.

$$f = 1/(100) \times (425 \text{ ns}) = 23,529 \text{ kHz}$$

$$\text{Resolution} = 25 \text{ kHz} - 23,529 \text{ kHz} = 1.47 \text{ kHz}$$

PHYSICAL/ENVIRONMENTAL

Dimensions: Standard VME double height board (160 x 233.5 mm)

Temperature: 0 to +65 °C, operating
-25 to +85 °C, storage

Relative Humidity: 20 to 80 percent, noncondensing

Cooling: Normal VMEbus chassis forced air circulation

Power Requirements: +5 VDC at 6.0 A maximum

Altitude: Operation to 10,000 ft (3,048 m)

Weight (Mass): 0.8 kg maximum

RELATED PRODUCTS — For applications requiring low pass output filters, VMIC provides the VMIVME-0197 Filter Modules. These modules are installed on the VMIVME-4145 board. Each module provides filtering for a single channel. Therefore, all four outputs may be filtered with a different cutoff frequency and filter type. All filters are Fourth Order, Salenkey Multiple Feedback Low Pass Filters.

<u>Filter Product</u>	<u>Type</u>	<u>Frequency Cutoff</u>
VMIVME-0197-101	Chebyshev	500 kHz
VMIVME-0197-102	Chebyshev	1.0 MHz
VMIVME-0197-201	Bessel	500 kHz
VMIVME-0197-202	Bessel	1.0 MHz

1. Initial accuracy is established directly after reference calibration and autocalibration. Voltages referenced to common analog ground point.
2. Output noise is specified at 3s standard deviations, which includes 99.7% of all noise peaks for a normal distribution. Glitch (transition) and BIT-switching noise is not included.
3. Output filter is not installed.
4. VMEbus transfer times using CPU-33.

TRADEMARKS

The VMIC logo is a registered trademark of VMIC. Other registered trademarks are the property of their respective owners.

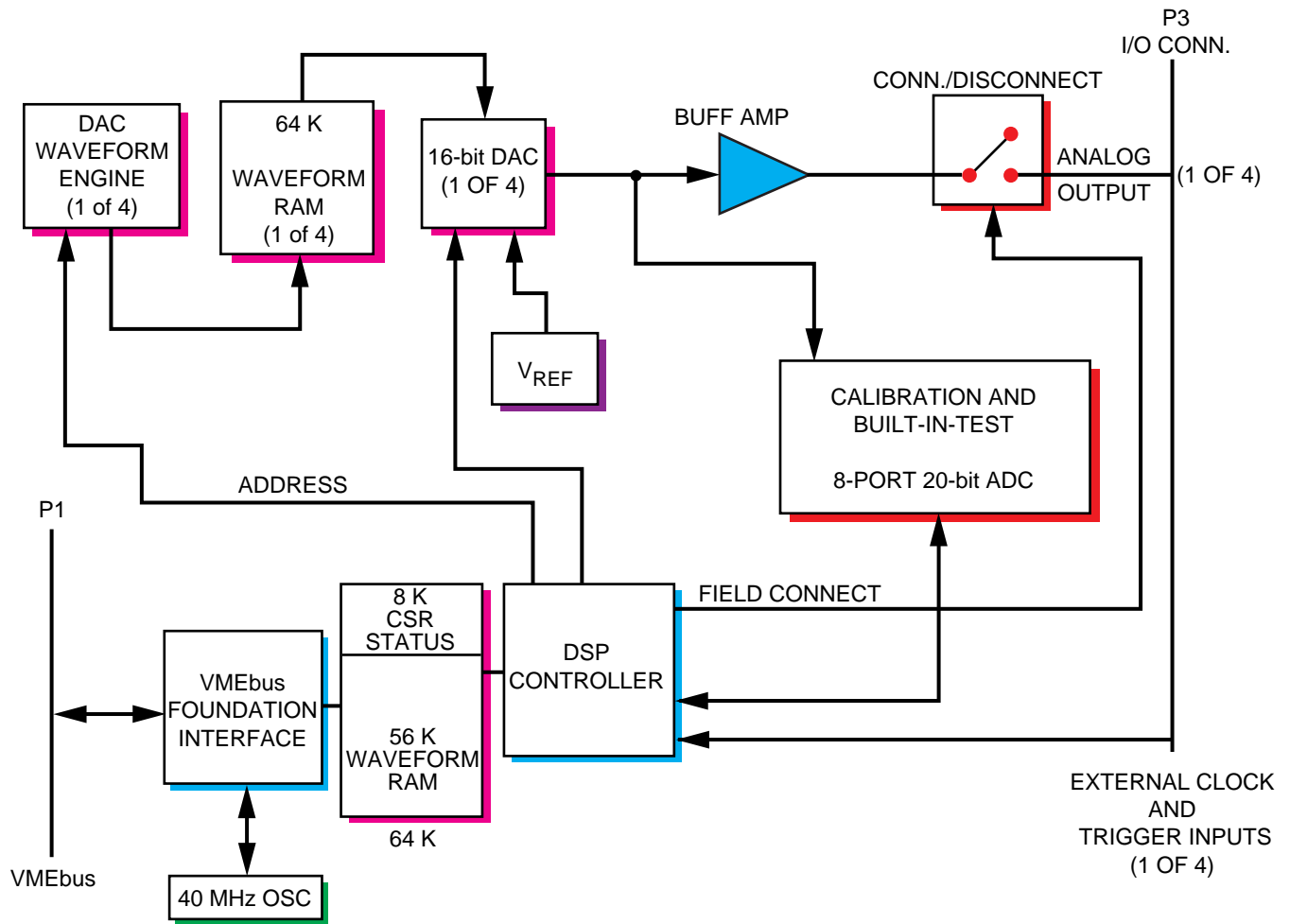

Figure 1. VMIVME-4145 4-Channel Arbitrary Waveform Analog Generator Board with Autocalibration Functional Block Diagram



Artisan Technology Group is your source for quality new and certified-used/pre-owned equipment

- FAST SHIPPING AND DELIVERY
- TENS OF THOUSANDS OF IN-STOCK ITEMS
- EQUIPMENT DEMOS
- HUNDREDS OF MANUFACTURERS SUPPORTED
- LEASING/MONTHLY RENTALS
- ITAR CERTIFIED SECURE ASSET SOLUTIONS

SERVICE CENTER REPAIRS

Experienced engineers and technicians on staff at our full-service, in-house repair center

*InstraView*SM REMOTE INSPECTION

Remotely inspect equipment before purchasing with our interactive website at www.instraview.com ↗

WE BUY USED EQUIPMENT

Sell your excess, underutilized, and idle used equipment. We also offer credit for buy-backs and trade-ins. www.artisanng.com/WeBuyEquipment ↗

LOOKING FOR MORE INFORMATION?

Visit us on the web at www.artisanng.com ↗ for more information on price quotations, drivers, technical specifications, manuals, and documentation

Contact us: (888) 88-SOURCE | sales@artisanng.com | www.artisanng.com