



Artisan Technology Group is your source for quality new and certified-used/pre-owned equipment

- FAST SHIPPING AND DELIVERY
- TENS OF THOUSANDS OF IN-STOCK ITEMS
- EQUIPMENT DEMOS
- HUNDREDS OF MANUFACTURERS SUPPORTED
- LEASING/MONTHLY RENTALS
- ITAR CERTIFIED SECURE ASSET SOLUTIONS

SERVICE CENTER REPAIRS

Experienced engineers and technicians on staff at our full-service, in-house repair center

*InstraView*SM REMOTE INSPECTION

Remotely inspect equipment before purchasing with our interactive website at www.instraview.com ↗

WE BUY USED EQUIPMENT

Sell your excess, underutilized, and idle used equipment. We also offer credit for buy-backs and trade-ins. www.artisanng.com/WeBuyEquipment ↗

LOOKING FOR MORE INFORMATION?

Visit us on the web at www.artisanng.com ↗ for more information on price quotations, drivers, technical specifications, manuals, and documentation

Contact us: (888) 88-SOURCE | sales@artisanng.com | www.artisanng.com



YASKAWA
MOTION CONTROL

PRODUCT INFORMATION

Product

Check:	R. Yasui	Publication No:	PI-6022
Translation/Creation:	Y. Mahan/th	Classification No:	DC-SGDA
Translated from:	DE9410938	Page:	1 of 18

CE Compatible Σ Series SGDA Servo Specifications

Introduction

The CE compatible Σ Series SGDA was developed for compatibility with overseas standards (low voltage standard, EMC directive) using the current Σ Series SGDA. Therefore, the basic specifications such as functions are the same as in the standard series. However, EMC directive compatibility is conditioned on box storage. For storage conditions refer to the Installation Manual (DE9409515).

Revision:			
A-0	Original Issue	12.11.96	

1. Model Type

CE compatible products are shown by voltage indication for both motors and servopacks.

The motor selection setting at shipment is SGM only for servopack.

1.1. Motor

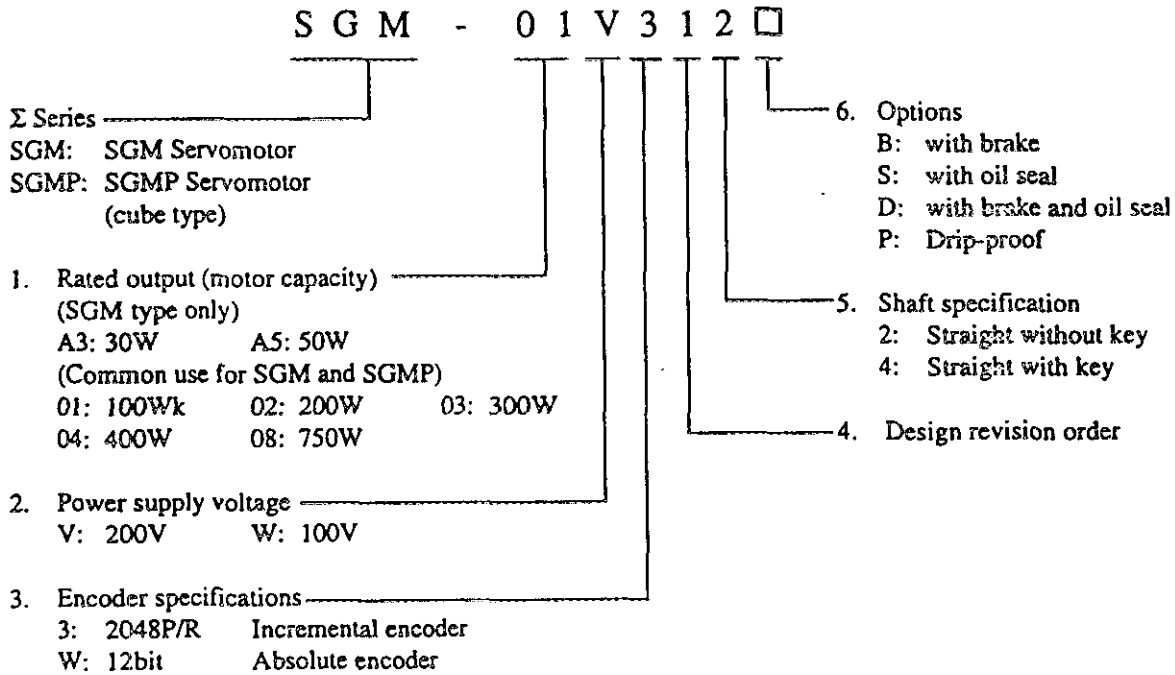

1.2 Servopack

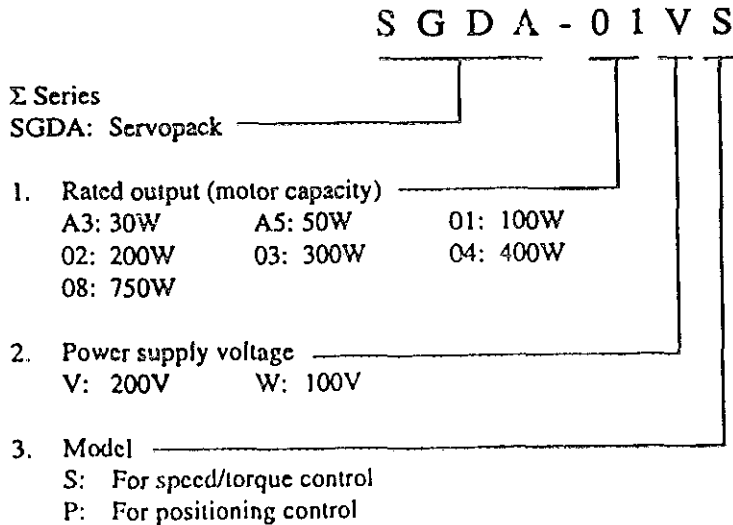

2. Rating and Specifications

2.1. Speed/Torque control servopack SGDA ratings, and specifications are shown below.

Voltage		200V						100V					
Servopack type SGDA-		A3VP	A5VP	G1VP	O2VP	O4VP	O8VP	A3WP	A5WP	O1WP	O2WP	O3WP	
Max. applicable motor capacity w (HP)		30 (0.04)	50 (0.07)	100 (0.13)	200 (0.27)	400 (0.53)	750 (1.01)	30 (0.04)	50 (0.07)	100 (0.13)	200 (0.27)	300 (0.40)	
Combined specifications	Type SGM (P)-	A3V□	A5V□	G1V□	O2V□	O4V□	O8V□	A3W□	A5W□	O1W□	O2W□	O3W□	
	Motor capacity W (HP)	30 (0.04)	50 (0.07)	100 (0.13)	200 (0.27)	400 (0.53)	750 (1.01)	30 (0.04)	50 (0.07)	100 (0.13)	200 (0.27)	300 (0.40)	
	Rated/Max. motor speed	3000/4500r/min						3000/4500r/min					
	Applicable encoder	Incremental encoder 2048 P/R, Absolute encoder 1024 P/R											
	Allowable load inertia *1 JL (×10 ⁻⁴ kg·m ²)	0.63	0.78	1.20	3.69	3.82	13.4	0.63	0.78	1.20	3.69	3.82	
	Continuous output current	0.42	0.6	0.87	2.0	2.6	4.4	0.63	0.90	2.2	2.7	3.7	
Max. output current	1.3	1.9	2.8	6.0	8.0	13.9	2.0	2.9	7.1	8.4	14.8		
Basic specifications	Power supply	Single-phase 200 to 230 VAC +10% to -15%, 50/60 Hz						Single-phase 100 to 115 VAC *2, +10% to -15%, 50/60 Hz					
	Control method	Single-phase, full-wave rectification IGBT-PWM (sine-wave driven)											
	Feedback	Incremental encoder 2048 P/R, Absolute encoder 1024 P/R											
	Location	Ambient temp.	0 to 55°C *3										
		Storage temp.	-20 to 85°C										
		Ambient/Storage humidity	90% or less (no condensation)										
		Vibration/Shock resistance	0.5/2G										
Structure	Base mounted												
Mass kg (lb)	0.9 (1.98)			1.2 (2.65)	1.5 (3.31)	0.9 (1.98)			1.2 (2.65)	1.5 (3.31)			
Performance	Speed control range**	1:5000											
	Variation speed**	Load variation	0~100% : 0.01% or less (at rated speed)										
		Voltage variation	0%										
		Temperature variation	25°±25°C : ±0.1% or less (at rated speed)										
	Frequency characteristics	250 Hz (at J _L = J _M)											
	Torque control (Reproducibility)	±2.0%											
Accel./decel. time setting	0 ~ 10s												
Input signal	Input speed command	Rated command voltage	± 6VDC (clockwise mototr rotation with a "+" signal) at rated speed (set upon delivery) Possible Setting Range: ±2 to ±10VDC at rated speed.										
		Input impedance	Approx. 30 kΩ										
		Circuit time constant	Approx. 47μs										
	Input Torque Command	Rated command voltage	± 3VDC (clockwise mototr rotation with a "+" signal) at rated torque (set upon delivery). Possible Setting Range: ±1 to ±10VDC at rated speed.										
		Input impedance	Approx. 30 kΩ										
		Circuit time constant	Approx. 47μs										



Voltage		200V	100V
I/O signals	Position output	Phase A, B and C: Line driver	
	Frequency dividing ratio	(16 to N)/N (N=2048, or 1024) **	
	Sequence input	Servo ON, P drive (or motor forward/reverse by internal speed setting,) forward run stop (P-OT), reserve run stop (N-OT), alarm reset, current limit + selection (or internal speed selection), current limit-selection (or internal speed selection)	
	Sequence output	Current limit detection (or TGON), positioning complete, brake interlock, servo alarm, 3-bit alarm codes	
Dynamic brake		Automatic, integrated DB operates at main power OFF, servo alarm or overtravel.	
External regenerative unit		Required when exceeding the allowable load inertia *1	
Over travel		Dynamic brake stop at P-OT or N-OT or deceleration stop	
Protective functions		Over current, grounding, overload, overvoltage, overspeed, reference input read error, overrun prevention, origin error, CPU error, encoder error	
Indicators		Alarm and power LEDs	
		Programming panel is available as an option	
Others		Brake interlock signal output, Reverse run connection, JOG run, Electronic gear, Auto-tuning	

*1 Allowable load inertia ranges require no optional external regenerative unit. Values are 30times the moment of the inertia for 30W (0.04HP) to 200W (0.27HP) rotor inertia, and 20times for 400W (0.53HP) and 750W (1.01HP) rotor inertia. If load inertias exceed these ranges, restrict the operation or use a regenerative unit.

*2: The power voltage must not exceed 230V +10% (253V) or 115V + 10% (127V). If it is likely to exceed this limit, use a step-down transformer.

*3: The ambient temperature must be within the specified range. Even if the Servopack is installed in a box, the temperature inside the box must not exceed the range.

*4: The lowest speed of the speed control range is the speed at which the motor does not stop under 100% load.

*5: Speed regulation can be calculated using the following formula:

$$\left(\text{Speed regulation} = \frac{(\text{No-load motor speed} - \text{full-load motor speed})}{\text{Rated motor speed}} \times 100\% \right)$$

Under actual operating conditions, voltage or temperature fluctuation causes the amplifier to drift or the operating resistance to change, resulting in the motor speed being changed. The percentage of the motor speed change to the rated motor speed is called the "speed regulation".

*6: N is the number of encoder pulses.



2.2. Position control servopack SGDA ratings, and specifications are shown below.

Voltage		200V						100V					
Servopack SGDA-		A3VP	A5VP	01VP	02VP	04VP	08VP	A3WP	A5WP	01WP	02WP	03WP	
Max. applicable motor capacity w (HP)		30 (0.04)	50 (0.07)	100 (0.13)	200 (0.27)	400 (0.53)	750 (1.01)	30 (0.04)	50 (0.07)	100 (0.13)	200 (0.27)	300 (0.40)	
Combined specifications	Motor	Type	A3V□	A5V□	01V□	02V□	04V□	08V□	A3W□	A5W□	01W□	02W□	03W□
		Motor capacity W (HP)	30 (0.04)	50 (0.07)	100 (0.13)	200 (0.27)	400 (0.53)	750 (1.01)	30 (0.04)	50 (0.07)	100 (0.13)	200 (0.27)	300 (0.40)
		Rated/Max. motor speed	3000/4500r/min						3000/4500r/min				
		Applicable encoder	Incremental encoder 2048 P/R, Absolute encoder 1024 P/R										
		Allowable load inertia*1 JL (X10 ⁻⁴ kg·m ²)	0.63	0.78	1.20	3.69	3.82	13.4	0.63	0.78	1.20	3.69	3.82
		Continuous output current	0.42	0.6	0.87	2.0	2.6	4.4	0.63	0.90	2.2	2.7	3.7
Max. output current		1.3	1.9	2.8	6.0	8.0	13.9	2.0	2.9	7.1	8.4	14.8	
Basic specifications	Power supply		Single-phase 200 to 230 VAC, +10% to -15%, 50/60 Hz *2					Single-phase 100 to 115 VAC*2, +10% to -15%, 50/60 Hz					
	Control method		Single-phase, full-wave rectification IGBT-PWM (sine-wave driven)										
	Feedback		Incremental encoder 2048 P/R, Absolute encoder 1024 P/R										
	Location	Ambient temp.		0 to 55°C *3									
		Storage temp.		-20 to 85°C									
		Ambient/Storage humidity		90% or less (no condensation)									
Vibration/Shock resistance		0.5/2G											
Structure		Base mounted											
Mass kg (lb)		0.9 (1.98)			1.2 (2.65)		1.5 (3.31)	0.9 (1.98)			1.2 (2.65)		1.5 (3.31)
Performance	Bias setting		0 to 450 r/min (setting resolution: 1 r/min)										
	Feed forward compensation		0 to 100%: (setting resolution: 1%)										
	Position complete width setting		0 to 250 reference units (reference unit: minimum unit of position data which moves load)										
Input signal	Reference pulse	Type	Sign+PULSE train, 90° phase difference 2-phase pulse (phaseA+phaseB), or CCW+CW pulse train.										
		Pulse form	Line driver (+5V level), open collector (+5V or +12V level)										
		Pulse frequency	0 to 450kpps										
Control signal		CLEAR signal (The input pulse form is the same as that of the command pulse)											
I/O signals	Position output	Output form	Phase A, B and C: Line driver										
		Frequency dividing ratio	(16 to N)/N (N= 2048, 1024) **										
	Sequence input		Servo ON, P drive (or motor forward/reverse by internal speed setting,) forward run stop (P-OT), reserve run stop (N-OT), alarm reset, current limit + selection (or internal speed selection), current limit-selection (or internal speed selection)										
	Sequence output		Current limit detection (or TGON), positioning complete, brake interlock, servo alarm, 3-bit alarm codes										
Dynamic brake		Operated at main power OFF, servo alarm or overtravel.											
External regenerative unit		Required when exceeding the allowable load inertia. *1											



Voltage	200V	100V
External regenerative unit	Required when exceeding the allowable load inertia. *1	
Over travel	Dynamic brake stop at P-OT or N-OT or deceleration stop	
Protective functions	Over current, grounding, overload, overvoltage, overspeed, reference input read error, overrun prevention, origin error, CPU error, encoder error,	
Indicators	Alarm and power LEDs	
	Programming panel is available as an open	
Others	Brake interlock signal output, Reverse run connection, JOG run, Electronic gear, Auto-tuning	

- *1 Allowable load inertia ranges require no optional external regenerative unit. Values are 30times the moment of the inertia for 30W (0.04HP) to 200W (0.27HP) servomotors, and 20times for 400W (0.53HP) and 750W (1.01HP) sevomotors. If load inertias exceed these ranges, restrict the operation or use a regenerative unit.
- *2: The power voltage must not exceed 230V +10% (253V) or 115V + 10% (127V). If it is likely to exceed this limit, use a step-down transformer.
- *3: The ambient temperature must be within the specified range. Even if the Servopack is installed in a box, the temperature inside the box must not exceed the range.
- *4: N is the number of encoder pulses. It represents the range in which the motor is not stopped by the load.

3. Connection

3.1. Main Circuit Terminals

Terminal names are as follows:

Terminal signals	Name	Remarks
(L1)(L2)	Main circuit power supply input terminals	3-phase 200 to 230AV, +10-15%, 50/60Hz *1
(U)(V)(W)	Motor connection terminals	Connect U to red motor terminal, V to white terminal, and W to blue terminal.
(⊕)	Grounding terminals	Connect to the motor grounding terminals (green), then drop into grounding. *2
(+)(-)	Regenerative resistance unit connection terminals	Connect to regenerative unit when regenerative unit is used.

*1: Single-phase 100 to 115 VAC, +10% to -15%, 50/60 Hz

*2: Connect the lead to the bracket at bottom of the servopack for dropping to the grounding.

3.2. I/O Signal Connector (1CN)

Connection of the upper-level controller and the grounding is executed using a shield. There is no Grounding Terminal

1 CN Terminal Layout (Speed Control Type).

2	SG	Torque reference input 0V	1	T-REF	Torque reference input	20	PAO	PG output phase A	19	SG	PG output signal 0V
4	SG	Speed reference input 0V	3	V-REF	Speed reference input	22	PBO	PG output phase B	21	*PAO	PG output phase A
6	0SEN	SEN signal input (absolute encoder only)	5	SEN	SEN signal input (absolute encoder only)	24	PCO	PG output phase C	23	*PBO	PG output phase B
8	V-CMP	Speed coincidence output	7	BK	Brake interlock signal output	26	PSO	PG output phase S (absolute encoder only)	25	*PCO	PG output phase C
10	SG-COM	BK/V-CMP/TGON common 0V	9	TGON	TGON signal output	28	BAT	Battery (+) (abso encoder only)	27	PSO	PG output phase S (absolute encoder only)
12	N-CL	Reversed external torque limit ON input	11	P-CL	Forward external torque limit ON input	30	ALO1	Alarm code output (open collector output)	29	BATO	Battery (-) (abso encoder only)
14	S-ON	Servo ON input	13	+24VIN	External power supply input	32	ALO3		31	ALO2	Alarm code output (open collector output)
16	P-OT	Forward rotation prohibited	15	P-CON	P control input	34	ALM	Servo alarm output	33	SG-AL	Alarm code output common 0V
18	ALMRST	Alarm reset input	17	N-OT	Reverse overtravel input	36			35	ALM-SG	Servo alarm output

Connector type on Servopack side: 10236-52A2JL (manufactured by 3M)
 Connector type on Cable side: 10136-3000VE (manufactured by 3M)
 Connector case type on Cable side: 10336-52A0-008 (manufactured by 3M)

1CN Terminal Layout (Position Control Type)

2	*PLUS	Command pulse input	1	*PLUS	Reference pulse input	20	PAO	PG output phase A	19	SG	PG output signal 0V
4	*SIGN	Command signal input	3	*SIGN	Reference signal input	22	PBO	PG output phase B	21	*PAO	PG output phase A
6	*CLR	Error counter clear input	5	*CLR	Error counter clear input	24	PCO	PG output phase C	23	*PBO	PG output phase B
8	(COIN+)	Positioning complete signal output	7	BK	Brake interlock signal output	26	PSO	PG output phase S (absolute encoder only)	25	*PCO	PG output phase C
10	SG-COM	BK/V-CMP/TGON common 0V	9	TGON	TGON signal output	28	BAT	Battery (+) (abso encoder only)	27	*PSO	PG output phase S (absolute encoder only)
12	N-CL	Reverse external torque limit ON input	11	P-CL	Forward external torque limit ON input	30	ALO1	Alarm code output (open collector output)	29	BATO	Battery (-) (abso encoder only)
14	S-ON	Servo ON input	13	+24VIN	External power supply input	32	ALO3		31	ALO2	Alarm code output (open collector output)
16	P-OT	Forward overtravel input	15	P-CON	P control input	34	ALM	Servo alarm output	33	SG-AL	Alarm code output common 0V
18	ALMRST	Alarm reset input	17	N-OT	Reverse overtravel input	36			35	ALM-SG	Servo alarm output

Connector type on Servopack side: 10236-52A2JL (manufactured by 3M)
 Connector type on Cable side: 10136-3000VE (manufactured by 3M)
 Connector case type on Cable side: 10336-52A0-008 (manufactured by 3M)

3.3. Encoder Signal Input Terminal (2CN)

Connection between the encoder and the ground is executed by the shield. There is no ground terminal.

2CN Terminal Layout

2	PG0V	PG power supply 0V	1	PG0V	PG power supply 0V	12	BAT+	Battery (+) (abso encoder only)	11		
4	PG5V	PG power supply +5V	3	PG0V		14	PC	PG input phase C	13	BAT-	Battery (-) (abso encoder only)
6	PG5V		5	PG5V	PG power supply +5V	16	PA	PG input phase A	15	*PC	PG input phase C
8	PS	PG input phase A (abso encoder only)	7	DIR	Rotation direct. input	18	PB	PG input phase B	17	*PA	PG input phase A
10			9	*PS	PG input phase S (abso. encoder only)	20			19	*PB	PG input phase B

Connector type on Servopack side: 10220-52A2JL (manufactured by 3M)
 Connector type on Cable side: 10120-3000VE (manufactured by 3M)
 Connector case type on Cable side: 10320-52A0-008 (manufactured by 3M)

3.4. Motor connection

Processing for the lead wires coming from the motor is as follows:

Power lines (U, V, W, FG): loose leads (without connector)

Encoder wire: D-sub connector by Daiichi electric industry

Refer to the dimension for details.

Attach the connectors on the motor side by using studs as shown in the figure below..

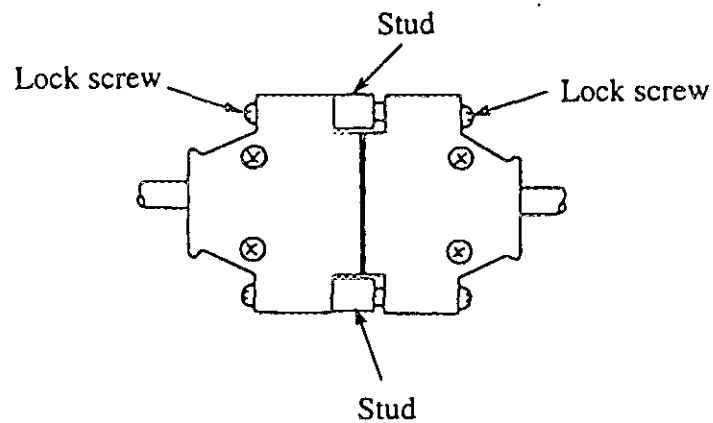

4. Dimensional Drawings

4.1. SGM Incremental Encoder, without Brake 30W-100W

Encoder cable connection spec. Motor cable connection spec.

1	A channel output	Blue	U phase	Red
2	A channel output	Blue/Black	V phase	White
3	B channel output	Yellow	W phase	Blue
4	B channel output	Yellow/Black	FG (frame ground)	Green/Yellow
5	C channel output	Green		
6	C channel output	Green/Black		
7	0V	Gray		
8	+5VDC	Red		
9	FG (frame ground)	Orange		

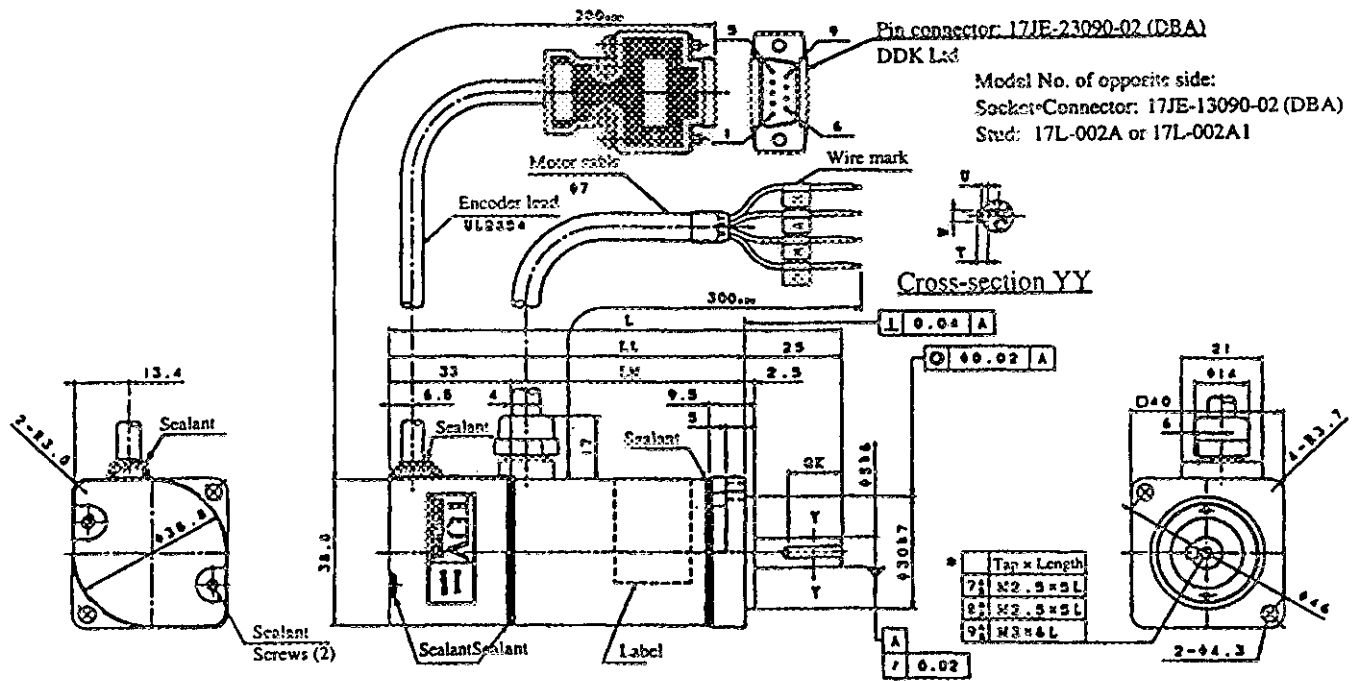

Item	Type	L (mm)	LL (mm)	LM (mm)	S (mm)	QK (mm)	U (mm)	W (mm)	T (mm)	Output (W)	Torque (N·m/kgf·cm)	Time duty	RPM (r/min)	Mass (kg)	Allowable radial (N/kgf)	Allowable thrust (N/kgf)
1 ^A _B	SGM-A3 V 312	94.5	69.5	36.5	6	without key				30	0.095/0.974	CONT	3000	0.3	5S/7	54/5.5
2 ^A _B	SGM-A3 V 312					14	1.2	2	2							
3 ^A _B	SGM-A5 V 312	102.0	77.0	44.0	6	without key				50	0.159/1.62			0.4	6B/7	54/5.5
4 ^A _B	SGM-A5 V 312					14	1.2	2	2							
5 ^A _B	SGM-01 V 312	119.5	94.5	61.5	8	without key				100	0.318/3.25	0.5	7B/8	54/5.5		
6 ^A _B	SGM-01 V 312					14	1.8	3	3							

200W, 400W (200V)

Encoder cable connection spec. Motor cable connection spec.

1	A channel output	Blue	U phase	Red
2	A channel output	Blue/Black	V phase	White
3	B channel output	Yellow	W phase	Blue
4	B channel output	Yellow/Black	FG (frame ground)	Green/Yellow
5	C channel output	Green		
6	C channel output	Green/Black		
7	0V	Gray		
8	+5VDC	Red		
9	FG (frame ground)	Orange		

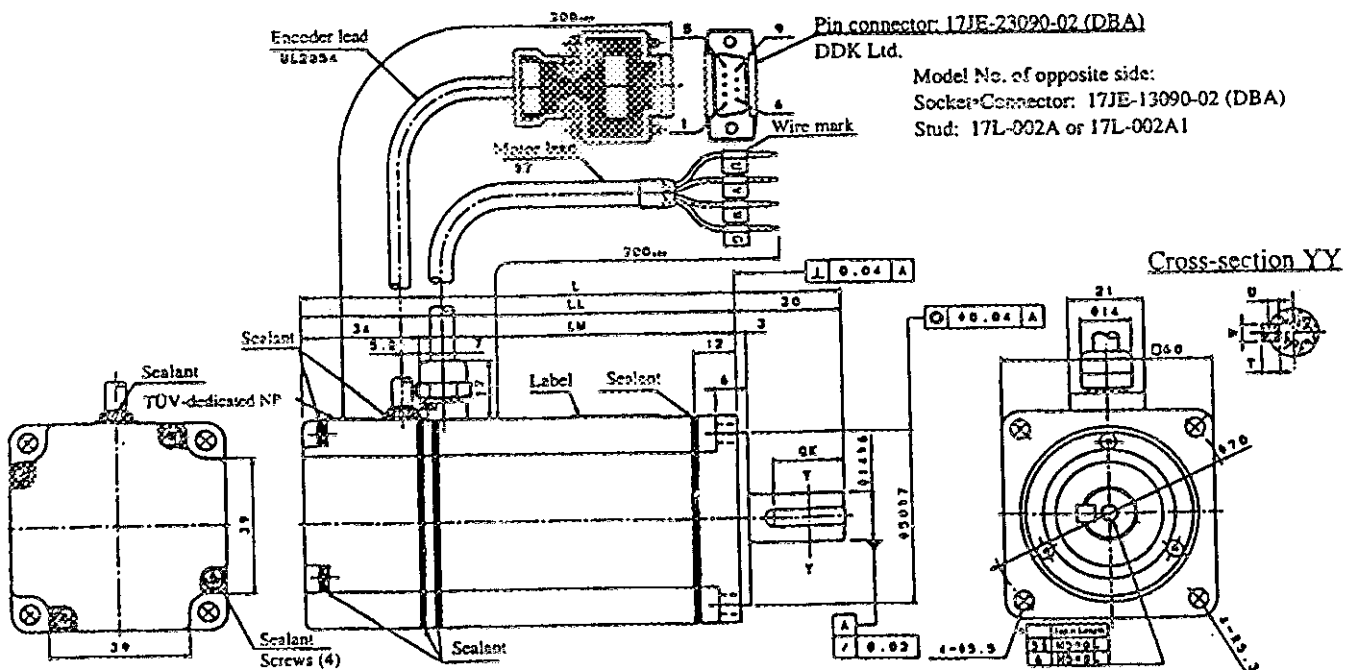

Item	Type	L (mm)	LL (mm)	LM (mm)	QK (mm)	U (mm)	W (mm)	T (mm)	Output (W)	Torque (N·m/kg·cm)	Time duty	RPM (r/min)	Mass (kg)	Allowable radial (N/kgf)	Allowable thrust (N/kgf)
1 ^A	SGM-A3V312	126.5	96.5	62.5	without key				200	0.637/6.49	CONT	3000	1.1	245/25	74/7.5
2 ^A	SGM-A3V314				20	3	5	5							
3	SGM-04V312	154.5	124.5	90.5	without key				400	1.27/13.0			1.7	245/25	74/7.5
4	SGM-04V314				20	3	5	5							

750W (200V)

Encoder cable connection spec. Motor cable connection spec.

1	A channel output	Blue	U phase	Red
2	A channel output	Blue/Black	V phase	White
3	B channel output	Yellow	W phase	Blue
4	B channel output	Yellow/Black	FG (frame ground)	Green/Yellow
5	C channel output	Green		
6	C channel output	Green/Black		
7	0V	Gray		
8	+5VDC	Red		
9	FG (frame ground)	Orange		

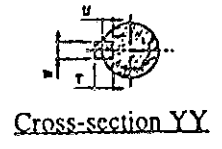
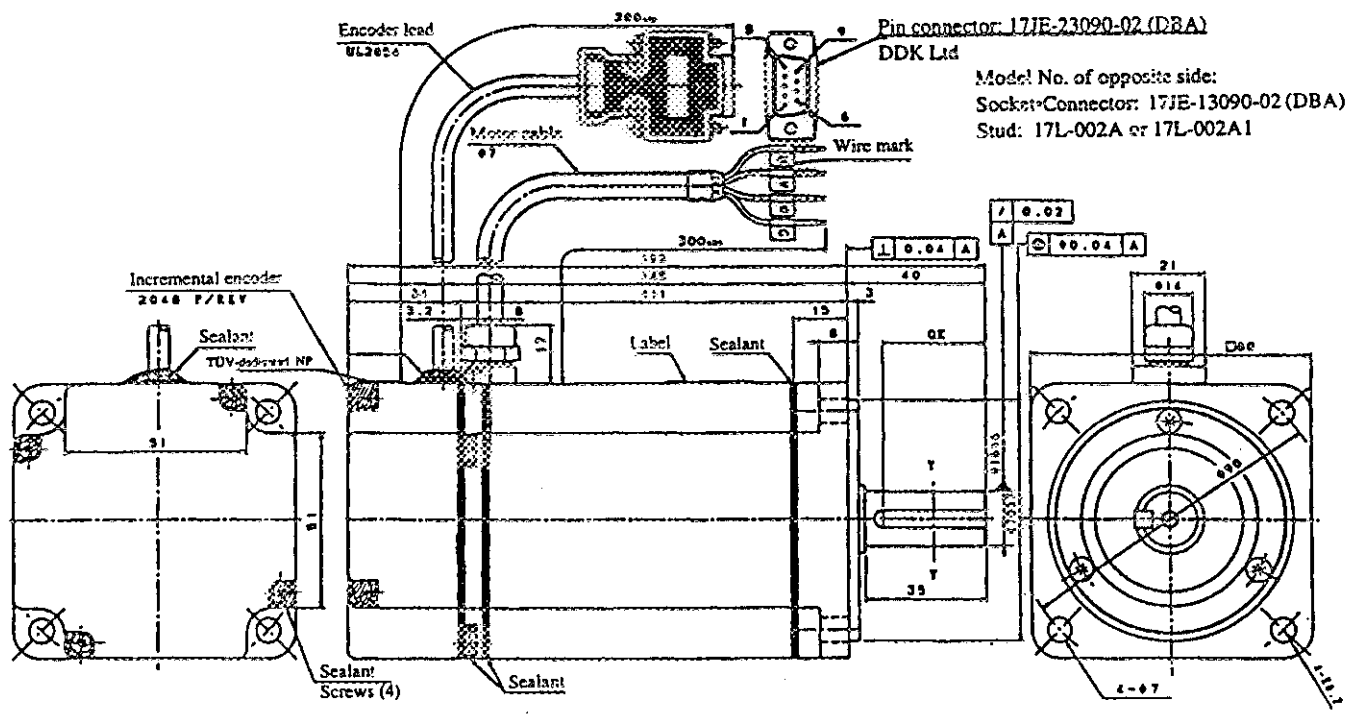

Item	Type	Shaft-end top	QK (mm)	U (mm)	W (mm)	T (mm)	Output (W)	Torque (N·m/kgf·cm)	Time duty	RPM (r/min)	Mass (kg)	Allowable radial (N/kgf)	Allowable thrust (N/kgf)
1	SGM-0NV312	without tap		without key			750	2.39/24.3	CONT	3000	3.4	392/40	147/15
2	SGM-0JV314	without tap	30	3	5	5							
3	SGM-0NV316	M5x8L	30	3	5	5							

4.2. SGMP Incremental Encoder, without Brake

Encoder cable connection spec. Motor cable connection spec.

1	A channel output	Blue	U phase	Red
2	A channel output	Blue/Black	V phase	White
3	B channel output	Yellow	W phase	Blue
4	B channel output	Yellow/Black	FG (frame ground)	Green/Yellow
5	C channel output	Green		
6	C channel output	Green/Black		
7	0V	Gray		
8	+5VDC	Red		
9	FG (frame ground)	Orange		

TUV Recognition Product
EMC Compatibility Product

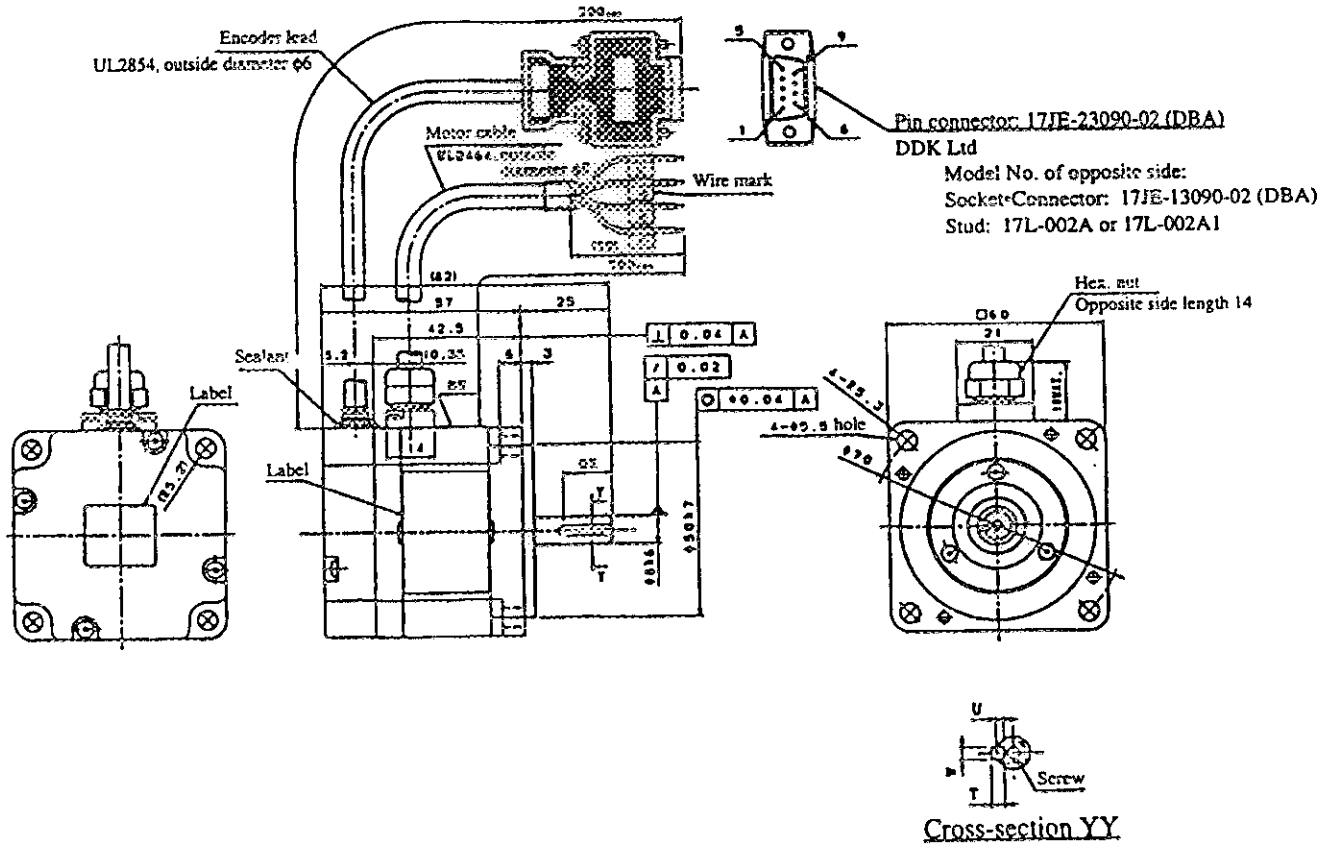

Item	Type	Screw	QK (mm)	U (mm)	W (mm)	T (mm)	Output (W)	Torque (N·m/kgf·cm)	Time duty	RPM (r/min)	Mass (kg)	Allowable radial (N/kgf)	Allowable thrust (N/kgf)
1 _V W	SGMP-01 _V W 312	without screw		without key			100	0.318/3.25	CONT	3000	0.7	78/8	49/5
2 _V W	SGMP-01 _V W 314	without screw	14	1.8	3	3							
3 _V W	SGMP-01 _V W 316	M3 screw depth 6	14	1.8	3	3							

200W, 300W (100V), 400W (200V)

Encoder cable connection spec. Motor cable connection spec.

1	A channel output	Blue	U phase	Red
2	A channel output	Blue/Black	V phase	White
3	B channel output	Yellow	W phase	Blue
4	C channel output	Yellow/Black	FG (frame ground)	Green/Yellow
5	C channel output	Green		
6	C channel output	Green/Black		
7	0V	Gray		
8	+5VDC	Red		
9	FG (frame ground)	Orange		

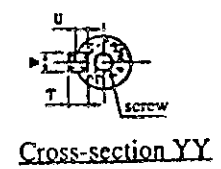
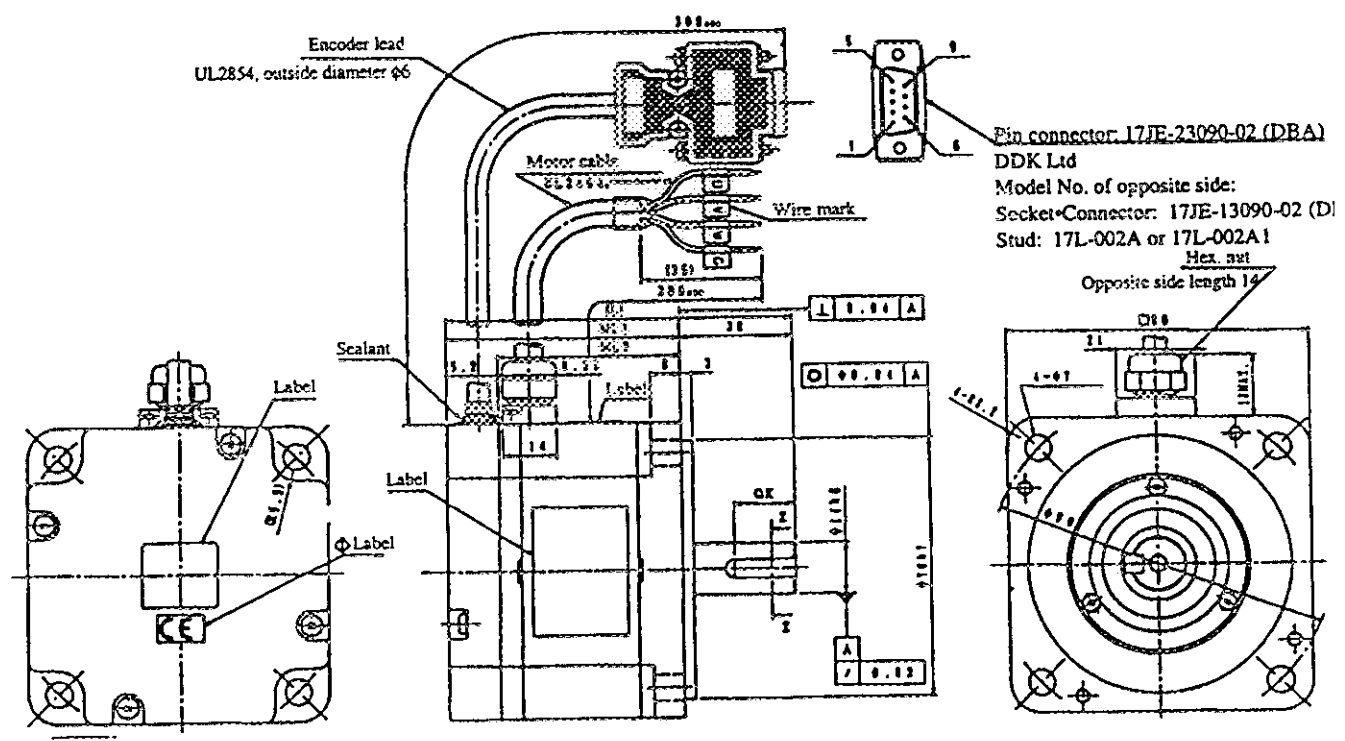

Item	Type	L (mm)	LL (mm)	LM (mm)	Screw size	QK (mm)	U (mm)	W (mm)	T (mm)	Output (W)	Torque (N·m/kg·cm)	Time duty	RPM (r/min)	Mass (kg)	Allowable radial (N/kgf)	Allowable thrust (N/kgf)
1 _w	SGMP-02 _w 312	92	62	48.1	w/o screw	without key				200	0.637/6.49			1.4		
2 _w	SGMP-02 _w 314				16	3	5	5								
3 _w	SGMP-02 _w 316				M5 depth R	16	3	5	5							
4 _v	SGMP-04 _v 312	112	82	68.1	w/o screw	without key				400	1.27/13.0	CONT	3000	2.1	245/25	68/7
5 _v	SGMP-04 _v 314				16	3	5	5								
6 _v	SGMP-04 _v 316				M5 depth R	16	3	5	5							
7 _w	SGMP-03 _w 312				w/o screw	without key				300	0.95/9.74					
8 _w	SGMP-03 _w 314				16	3	5	5								
9 _w	SGMP-03 _w 316				M5 depth R	16	3	5	5							

750W (200V)

Encoder cable connection spec. Motor cable connection spec.

1	A channel output	Blue	U phase	Red
2	A channel output	Blue/Black	V phase	White
3	B channel output	Yellow	W phase	Blue
4	S channel output	Yellow/Black	FG (frame ground)	Green/Yellow
5	C channel output	Green		
6	C channel output	Green/Black		
7	0V	Gray		
8	+5VDC	Red		
9	FG (frame ground)	Orange		

Pin connector: 17JE-23090-02 (DBA)
 DDK Ltd
 Model No. of opposite side:
 Socket-Connector: 17JE-13090-02 (D1)
 Stud: 17L-002A or 17L-002A1

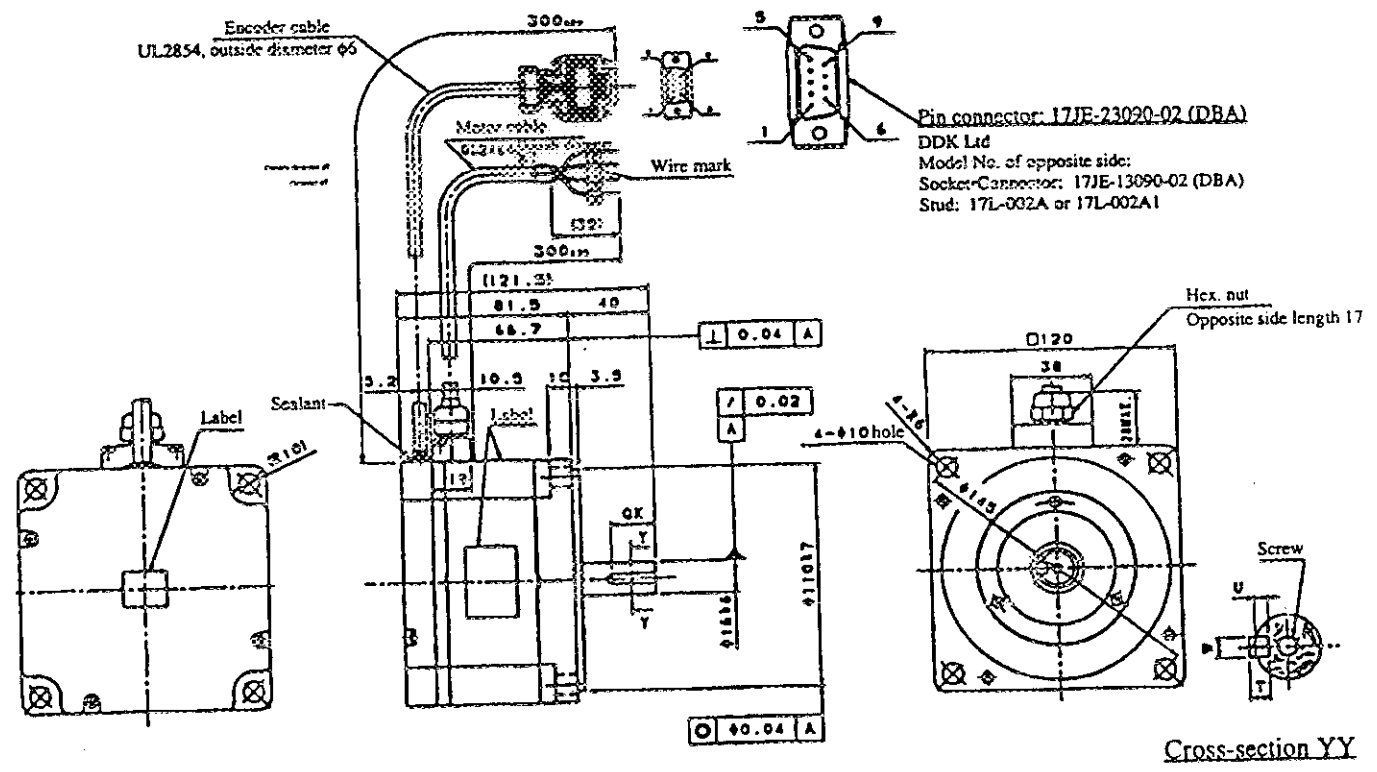

Item	Type	Screw	QK (mm)	U (mm)	W (mm)	T (mm)	Output (W)	Torque (N·m/kgf·cm)	Time duty	RPM (r/min)	Mass (kg)	Allowable radial (N/kgf)	Allowable thrust (N/kgf)
1	SGMP-08V312	without screw		without key			750	2.39/24.3	CONT	3000	4.2	392/40	147/15
2	SGMP-08V314	without screw	22	3	5	5							
3	SGMP-08V316	M3 screw depth	22	3	5	5							

30, 50, 100, 200 (200V only) W

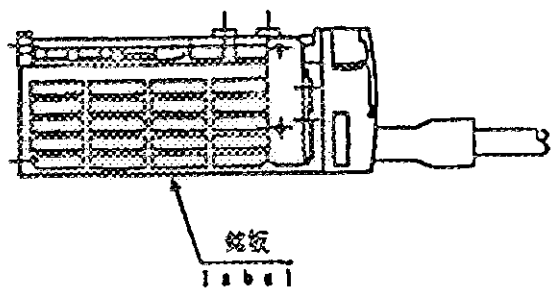
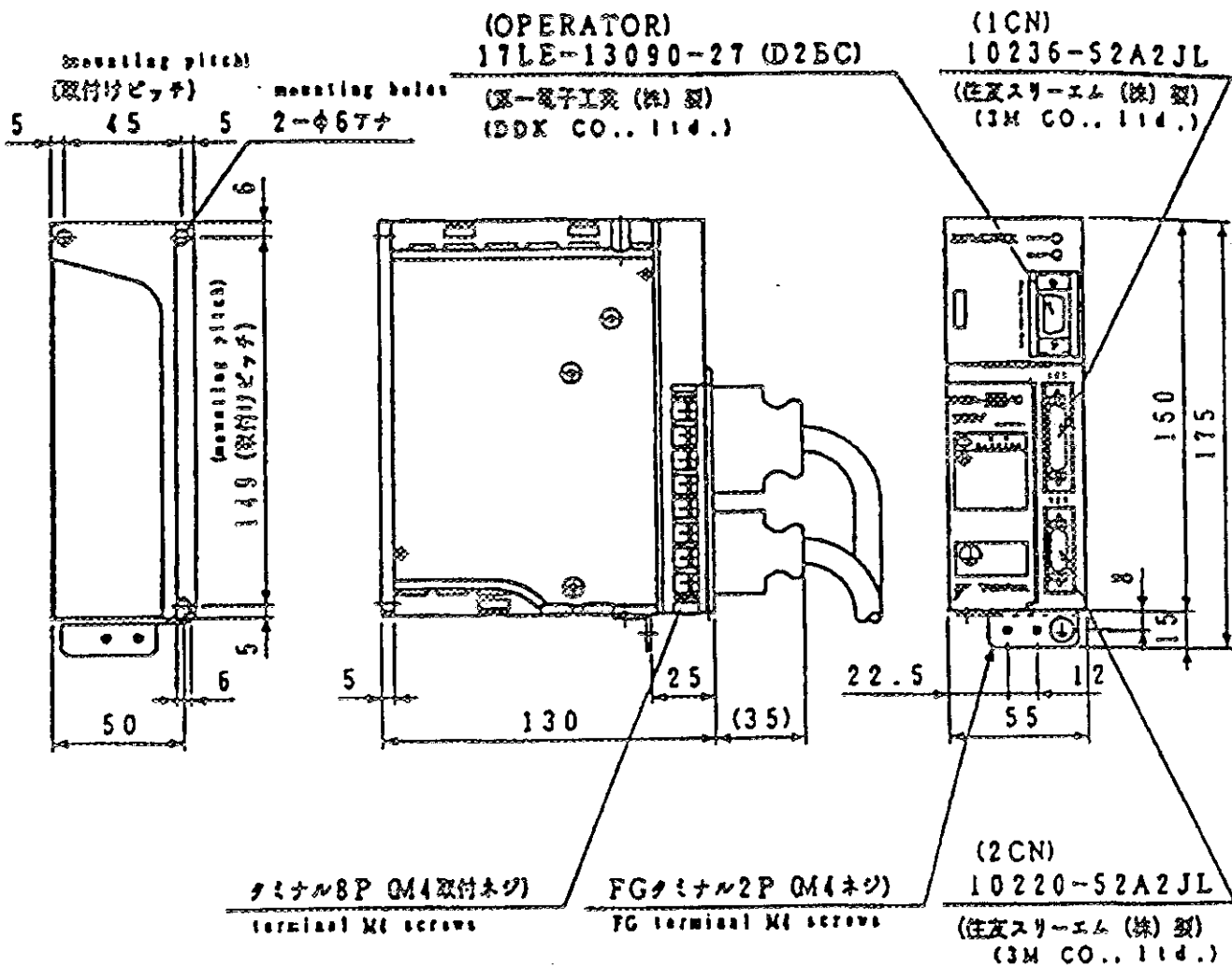

200 W (100V only), 400W (200V only)

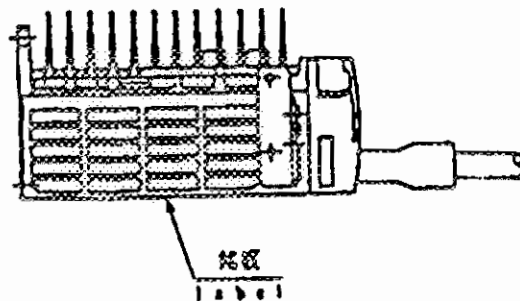
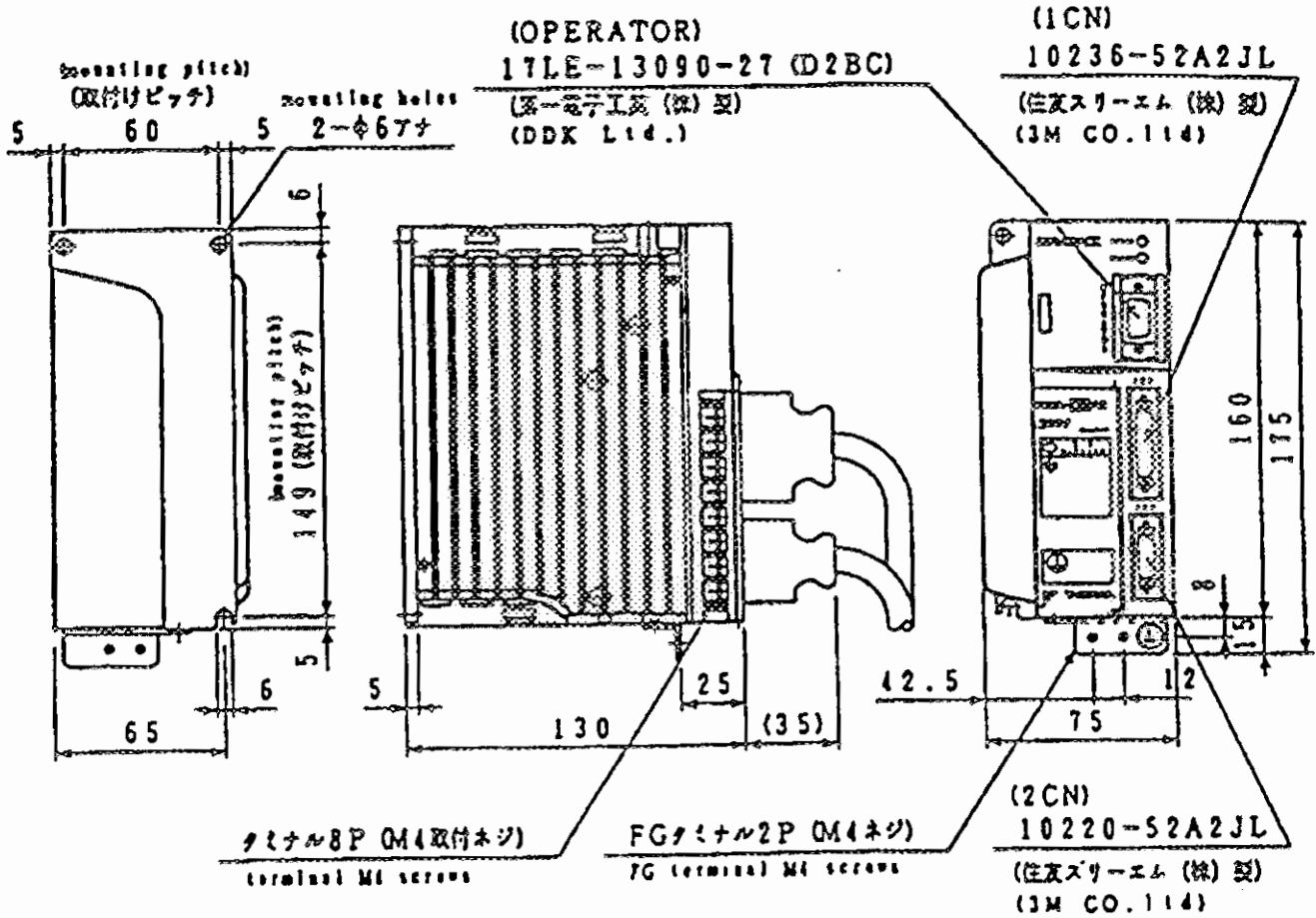

300W (100V only), 750W (200V only)

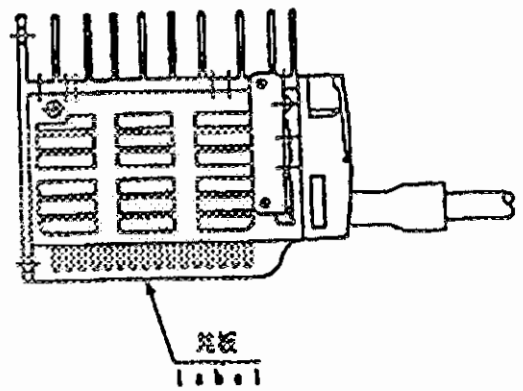
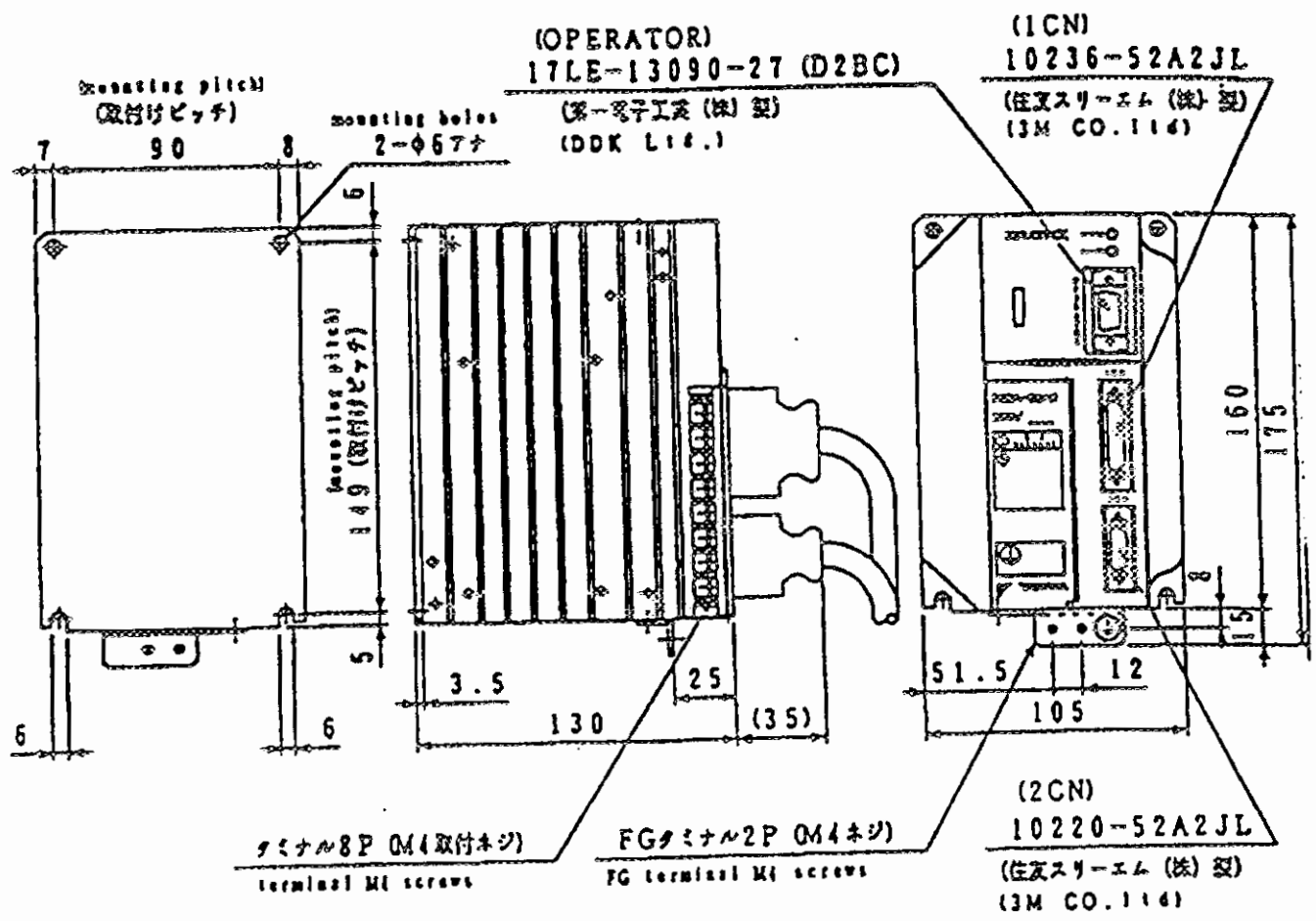



Artisan Technology Group is your source for quality new and certified-used/pre-owned equipment

- FAST SHIPPING AND DELIVERY
- TENS OF THOUSANDS OF IN-STOCK ITEMS
- EQUIPMENT DEMOS
- HUNDREDS OF MANUFACTURERS SUPPORTED
- LEASING/MONTHLY RENTALS
- ITAR CERTIFIED SECURE ASSET SOLUTIONS

SERVICE CENTER REPAIRS

Experienced engineers and technicians on staff at our full-service, in-house repair center

*InstraView*SM REMOTE INSPECTION

Remotely inspect equipment before purchasing with our interactive website at www.instraview.com ↗

WE BUY USED EQUIPMENT

Sell your excess, underutilized, and idle used equipment. We also offer credit for buy-backs and trade-ins. www.artisanng.com/WeBuyEquipment ↗

LOOKING FOR MORE INFORMATION?

Visit us on the web at www.artisanng.com ↗ for more information on price quotations, drivers, technical specifications, manuals, and documentation

Contact us: (888) 88-SOURCE | sales@artisanng.com | www.artisanng.com